



Is Now Part of



ON Semiconductor®

To learn more about ON Semiconductor, please visit our website at

www.onsemi.com

ON Semiconductor and the ON Semiconductor logo are trademarks of Semiconductor Components Industries, LLC dba ON Semiconductor or its subsidiaries in the United States and/or other countries. ON Semiconductor owns the rights to a number of patents, trademarks, copyrights, trade secrets, and other intellectual property. A listing of ON Semiconductor's product/patent coverage may be accessed at www.onsemi.com/site/pdf/Patent-Marking.pdf. ON Semiconductor reserves the right to make changes without further notice to any products herein. ON Semiconductor makes no warranty, representation or guarantee regarding the suitability of its products for any particular purpose, nor does ON Semiconductor assume any liability arising out of the application or use of any product or circuit, and specifically disclaims any and all liability, including without limitation special, consequential or incidental damages. Buyer is responsible for its products and applications using ON Semiconductor products, including compliance with all laws, regulations and safety requirements or standards, regardless of any support or applications information provided by ON Semiconductor. "Typical" parameters which may be provided in ON Semiconductor data sheets and/or specifications can and do vary in different applications and actual performance may vary over time. All operating parameters, including "Typicals" must be validated for each customer application by customer's technical experts. ON Semiconductor does not convey any license under its patent rights nor the rights of others. ON Semiconductor products are not designed, intended, or authorized for use as a critical component in life support systems or any FDA Class 3 medical devices or medical devices with a same or similar classification in a foreign jurisdiction or any devices intended for implantation in the human body. Should Buyer purchase or use ON Semiconductor products for any such unintended or unauthorized application, Buyer shall indemnify and hold ON Semiconductor and its officers, employees, subsidiaries, affiliates, and distributors harmless against all claims, costs, damages, and expenses, and reasonable attorney fees arising out of, directly or indirectly, any claim of personal injury or death associated with such unintended or unauthorized use, even if such claim alleges that ON Semiconductor was negligent regarding the design or manufacture of the part. ON Semiconductor is an Equal Opportunity/Affirmative Action Employer. This literature is subject to all applicable copyright laws and is not for resale in any manner.

Application Note AN-3006

Optically Isolated Phase Controlling Circuit Solution

Introduction

Optocouplers simplify logic isolation from the ac line, power supply transformations, and the control of polyphase power systems. They help solve problems by keeping ac line noise and transients out of sensitive logic. Fairchild's 6-Pin Dip Optocoupler family, with high surge voltage capability (7500 volts peak ac, 60 Hz, 1 second duration), allows designers to achieve their goals. This paper presents a power triac phase control circuit and contrasts it with the traditional zero-crossing circuit. The example circuit isolates the low level control circuitry from the ac line. It is able to control the speed of a universal motor or brilliance of a lamp. The universal motor is capable of high starting torque and wide speed range — commonly used in mixers, blenders, floor polishers, electric hand and woodworking tools, etc.

Zero-Crossing and Random Phase Triac Drivers

The zero-crossing triac driver optocouplers are the MOC316X and MOC308X series. The random phase optocouplers are the MOC301X, MOC302X and MOC305X series. All families have the same type of aluminum gallium arsenide infrared light-emitting diode but optically couple to different monolithic silicon detector chips. The zero-cross family is designed for interface applications between control circuit and power loads. The advantage of using zero-crossing switching is less surge current and resulting electromagnetic interference (EMI). This reduces reliability problems in many applications such as solid-state relays, industrial controls, motors, solenoids and consumer appliances. The high-speed zero-crossing switch provides a minimum dv/dt

from 500 V/μs to 2000 V/μs, protecting the device from accidental triggering by ac power line transients.

The circuit in Figure 1 is the basic circuit for on-off power control. With a continuous forward current through the LED, the detector of the zero-crossing optocoupler switches to the conducting state only when the applied ac voltage passes through a point near zero. Phase control applications, such as controlling the speed of a motor or brilliance of a lamp, require triggering at points along the ac voltage wave. This necessitates a random phase triac driver optocoupler.

Phase Controlling a Power Triac Using MOC3023

Design Objective

The application circuit shown in figure 2 is an example of phase controlling a power triac. The random phase triac driver is Fairchild's MOC3023. It has an LED trigger current I_{FT} of 5 mA and off-state output terminal voltage V_{DRM} of 400 V. The power triac used in this example has an on-state (RMS) current of 15 Amps at $T_C = 80C$. The load is a 1/3 HP, single phase induction motor driving a fan with maximum speed of 1750 rpm. This circuit can be applied to different power triacs and loads with larger rating. The design objective is to phase control a power triac that drives a motor or a light dimmer powered from the 115 VAC line. This is accomplished by using a variable pulse width generated from an optically isolated logic system with a control voltage of 5 to 15 VDC.

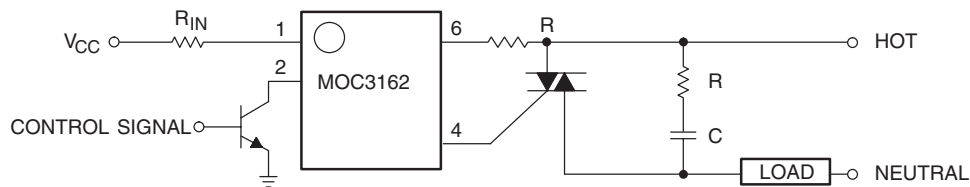

DESIGN RULE: $V_{peak}/I_{peak} = 180 / 1 \text{ amp} = 180 \text{ ohms}$
(Assume the line voltage is 115 volts RMS)

Figure 1. Zero-Cross Switching Using MOC3061

System Block Diagram

The full wave zero-crossing sensor is connected to an optically isolated variable pulse width oscillator. The oscillator controls the conduction time of the optically isolated power triac, thus providing phase control to the load.

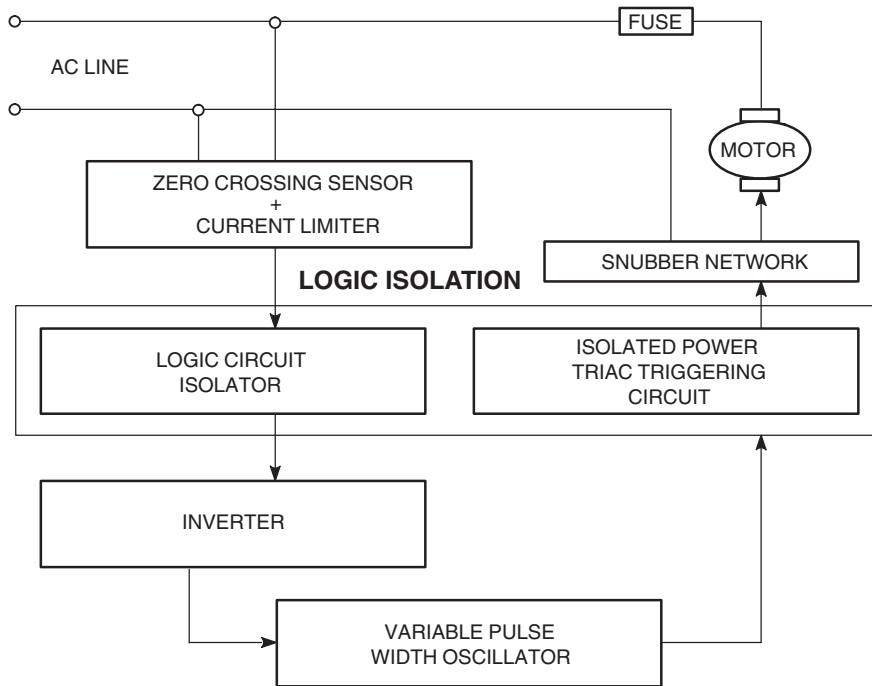

Figure 2. System Block Diagram

Circuit Description

Full Wave AC to Logic Coupling

The circuit begins with the ac line input voltage. It is rectified by the 1N4001 diode bridge rectifier and connected to the gallium arsenide LED of the H11L1 logic output optocoupler. A forward current (set between 10 and 50 mA) flows through the optocoupler LED, generating infrared radiation that triggers the high speed Schmitt trigger output stage into conduction. This occurs every half ac cycle, near the line zero crossing, at a constant input voltage defined by the zener diode.

Current Limiters

R1 is the limiting resistor for both the zener diode and the input LED of the optocoupler. R2 provides a small bias current to ensure the zener operates on the linear portion of its characteristic above the knee. It facilitates on-off switching of the LED by providing a path for leakage currents.

$$R1 = (V_{IN} - V_F) / I_F \quad \text{where}$$

V_F = diode forward voltage
I_F = diode forward current

Optically Isolated Triggering of the Variable Pulse Width Oscillator

A dc signal with a pulse width of 720μs is generated at the output detector of the H11L1. The purpose of the MPSA40 NPN transistor is to generate an inverted signal, which goes into the trigger pin 2 of the LM555 monolithic timing circuit. See Figure 4 for the input trigger pulse versus the line voltage.

The Variable Pulse Width Oscillator

At every falling edge of the input trigger signal, the LM555 monolithic timing circuit generates a positive going pulse with duty cycle controlled by C1, VR1 and R5. The pulse duration is measured in time constants of $t = 1.1 * (VR1 + R5) * C1$. See Figure 5 for the voltage across capacitor C1 versus the input trigger signal of the LM555.

Isolated Triac Triggering

The output signal (V_{td}) from the oscillator goes to the MOC3023 triac driver LED. When sufficient LED current (I_{FT}) passes through the LED, the triac driver latches on and generates a gate current in the power triac, triggering it into the conducting state.

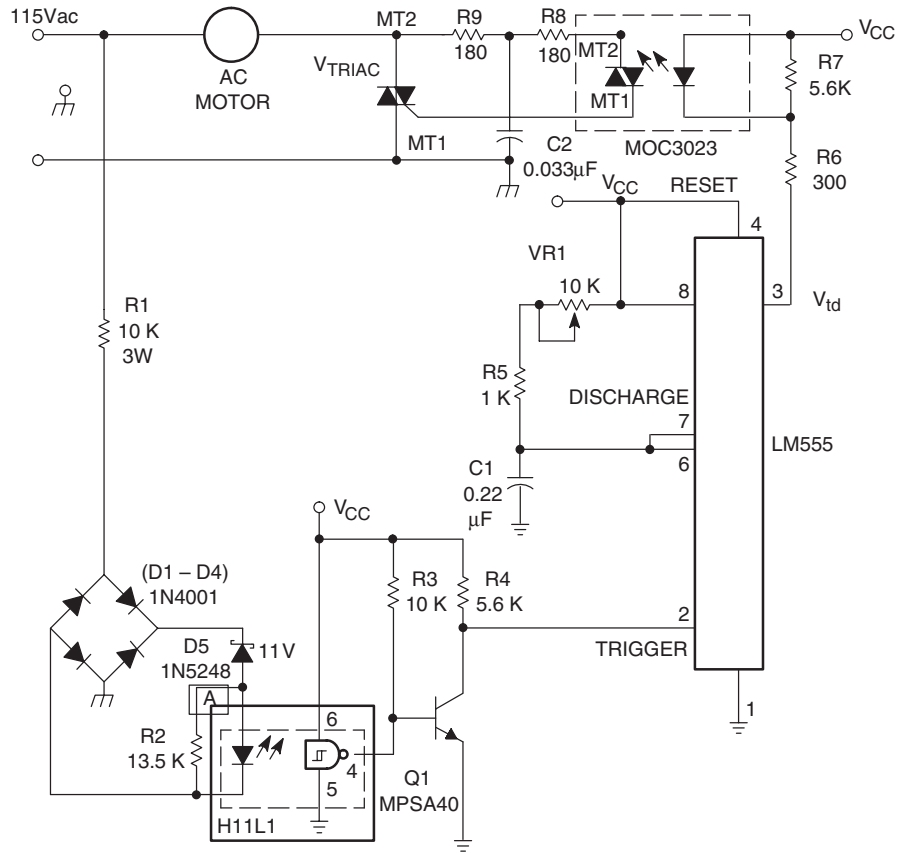

Figure 3. Schematic Diagram
Phase Controlling a Power Triac Using MOC3023

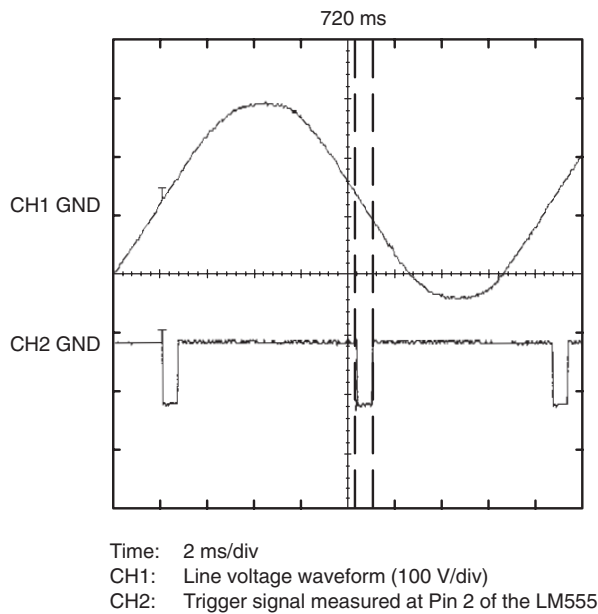

Figure 4. Zero Cross AC to Logic Coupling

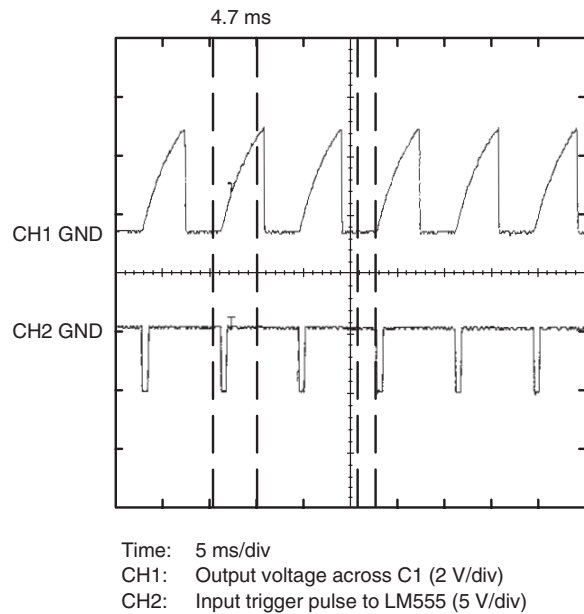

Figure 5. Capacitor C1 starts to charge up at the falling edge of the input trigger pulse with a time constant equal to $1.1 \cdot R5 \cdot C1$

Once the power triac latches on, the triac driver will be forced into off-state even when I_{FT} is applied. The power triac MT2 to gate voltage falls to a low value below the optocoupler's threshold voltage and cannot hold the optocoupler on. See Figure 8 for voltage across the power triac terminals (V_{TRIAC}) versus power triac gate trigger signal (V_{td}).

Minimum Load Power for Phase Control

The average power applied to the load is modulated by the duration of the waveform input to the triac driver. The longer the phase delay, the smaller the conduction angle and power delivered to the load. R5, VR1 and C1 set the minimum load power. This ensures power triac latching and optocoupler turn-off. This prevents optocoupler commutating dv/dt failure. The circuit in Figure 3 has a minimum conduction angle of 12 degrees. See Figure 9 for the voltage across the power triac terminals versus the input signal of the triac driver.

Snubber Network

The power triac can be switched on unintentionally if the rate of rise in applied voltage exceeds its dv/dt or the dv/dt of the triac driver. To prevent this false triggering, a single snubber limits the maximum dv/dt seen by the power triac and optocoupler. Snubber networks can be defined by assuming a power factor for the inductive load and modified later by measuring the actual dv/dt and adjusting the snubber as required. The snubber network used in Figure 3 results in a worst case dv/dt at the coupler of:

$$dv/dt = V_{to} / (R9 * C2) = 180 / (180 * 0.033) \\ = 30.3 \text{ V}/\mu\text{s}$$

V_{to} = instantaneous peak line voltage

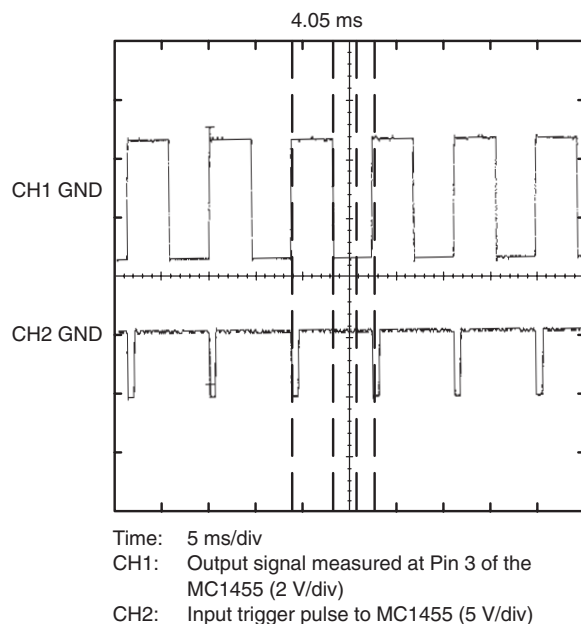

Figure 6. Square Wave with Pulse Width of 4.2 ms Generated at Output Pin of the LM555

The presence of load inductance (for example, when the load is a motor) results in significantly lower values of dv/dt. For details on designing the snubber network, refer to Fairchild application note AN3008.

R8 limits the peak capacitor discharge current through the triac driver. Its minimum value calculates as:

$$R8 = V_{pk} / I_{max} = 180 / 1.2 \text{ A} = 150 \text{ ohm (1/2 W)}$$

V_{pk} – gate trigger required voltage
 I_{max} – rated surge current of the optocoupler

The author selected 180 ohms for the limiting resistor.

Conclusion

This application note demonstrates the use of triac drivers and power triacs in an ac logic isolation phase control application. The circuit designs are easily accomplished with relatively few components.

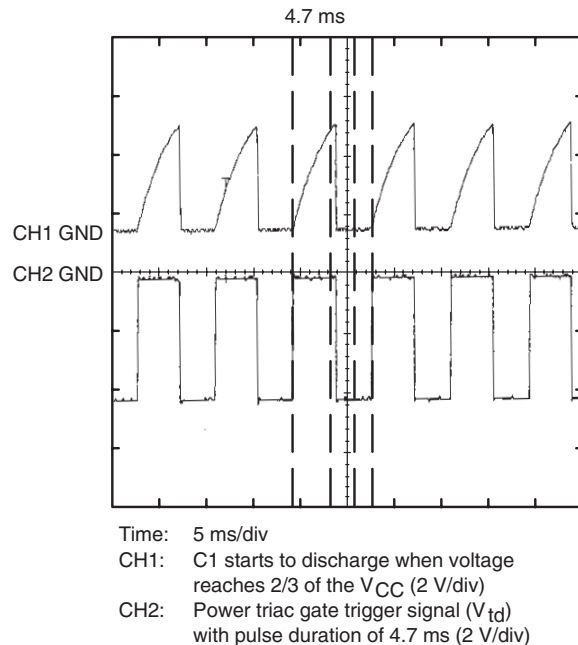
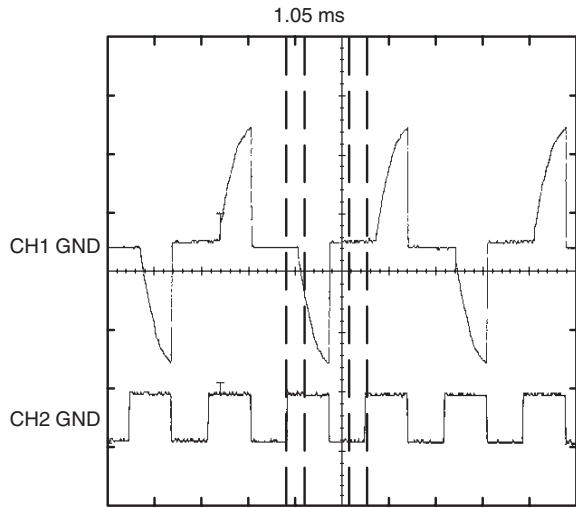
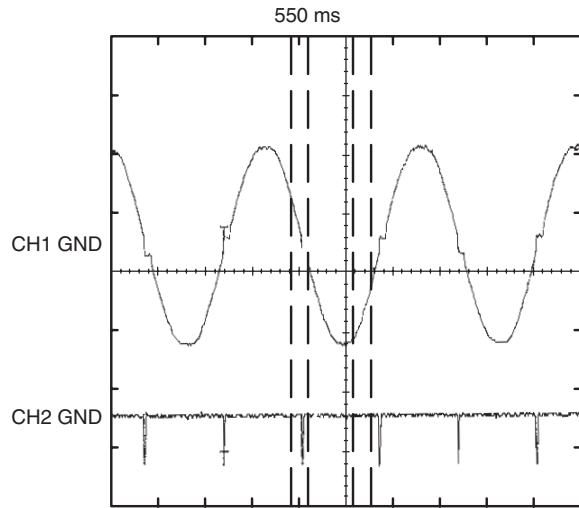

Figure 7. Capacitor Voltage versus Power Triac Gate Trigger Signal



Time: 5 ms/div
 CH1: Voltage across the power triac terminals (V_{TRIAC}) (100 V/div)
 CH2: Power triac gate trigger signal, V_{td} (5 V/div)

Figure 8. Power Triac



Time: 5 ms/div
 CH1: Voltage across the power triac terminals (V_{TRIAC}) (100 V/div)
 CH2: Power triac gate trigger, V_{td} (5 V/div)

Figure 9. Minimum Load Power

DISCLAIMER

FAIRCHILD SEMICONDUCTOR RESERVES THE RIGHT TO MAKE CHANGES WITHOUT FURTHER NOTICE TO ANY PRODUCTS HEREIN TO IMPROVE RELIABILITY, FUNCTION OR DESIGN. FAIRCHILD DOES NOT ASSUME ANY LIABILITY ARISING OUT OF THE APPLICATION OR USE OF ANY PRODUCT OR CIRCUIT DESCRIBED HEREIN; NEITHER DOES IT CONVEY ANY LICENSE UNDER ITS PATENT RIGHTS, NOR THE RIGHTS OF OTHERS.

LIFE SUPPORT POLICY

FAIRCHILD'S PRODUCTS ARE NOT AUTHORIZED FOR USE AS CRITICAL COMPONENTS IN LIFE SUPPORT DEVICES OR SYSTEMS WITHOUT THE EXPRESS WRITTEN APPROVAL OF THE PRESIDENT OF FAIRCHILD SEMICONDUCTOR CORPORATION. As used herein:

1. Life support devices or systems are devices or systems which, (a) are intended for surgical implant into the body, or (b) support or sustain life, or (c) whose failure to perform when properly used in accordance with instructions for use provided in the labeling, can be reasonably expected to result in significant injury to the user.
2. A critical component is any component of a life support device or system whose failure to perform can be reasonably expected to cause the failure of the life support device or system, or to affect its safety or effectiveness.

ON Semiconductor and  are trademarks of Semiconductor Components Industries, LLC dba ON Semiconductor or its subsidiaries in the United States and/or other countries. ON Semiconductor owns the rights to a number of patents, trademarks, copyrights, trade secrets, and other intellectual property. A listing of ON Semiconductor's product/patent coverage may be accessed at www.onsemi.com/site/pdf/Patent-Marking.pdf. ON Semiconductor reserves the right to make changes without further notice to any products herein. ON Semiconductor makes no warranty, representation or guarantee regarding the suitability of its products for any particular purpose, nor does ON Semiconductor assume any liability arising out of the application or use of any product or circuit, and specifically disclaims any and all liability, including without limitation special, consequential or incidental damages. Buyer is responsible for its products and applications using ON Semiconductor products, including compliance with all laws, regulations and safety requirements or standards, regardless of any support or applications information provided by ON Semiconductor. "Typical" parameters which may be provided in ON Semiconductor data sheets and/or specifications can and do vary in different applications and actual performance may vary over time. All operating parameters, including "Typicals" must be validated for each customer application by customer's technical experts. ON Semiconductor does not convey any license under its patent rights nor the rights of others. ON Semiconductor products are not designed, intended, or authorized for use as a critical component in life support systems or any FDA Class 3 medical devices or medical devices with a same or similar classification in a foreign jurisdiction or any devices intended for implantation in the human body. Should Buyer purchase or use ON Semiconductor products for any such unintended or unauthorized application, Buyer shall indemnify and hold ON Semiconductor and its officers, employees, subsidiaries, affiliates, and distributors harmless against all claims, costs, damages, and expenses, and reasonable attorney fees arising out of, directly or indirectly, any claim of personal injury or death associated with such unintended or unauthorized use, even if such claim alleges that ON Semiconductor was negligent regarding the design or manufacture of the part. ON Semiconductor is an Equal Opportunity/Affirmative Action Employer. This literature is subject to all applicable copyright laws and is not for resale in any manner.

PUBLICATION ORDERING INFORMATION

LITERATURE FULFILLMENT:

Literature Distribution Center for ON Semiconductor
19521 E. 32nd Pkwy, Aurora, Colorado 80011 USA
Phone: 303-675-2175 or 800-344-3860 Toll Free USA/Canada
Fax: 303-675-2176 or 800-344-3867 Toll Free USA/Canada
Email: orderlit@onsemi.com

N. American Technical Support: 800-282-9855 Toll Free
USA/Canada
Europe, Middle East and Africa Technical Support:
Phone: 421 33 790 2910
Japan Customer Focus Center
Phone: 81-3-5817-1050

ON Semiconductor Website: www.onsemi.com
Order Literature: <http://www.onsemi.com/orderlit>
For additional information, please contact your local
Sales Representative