

FOR ENERGY EFFICIENT INNOVATIONS

www.onsemi.com

THINK ON.

IGBT isolated driver supply 3W 15V/-7.5

SECO-LVDCDC-3064-IGBT-GEVB

Public Information



IGBT isolated driver supply 3W 15V/-7.5

The SECO-LVDCDC-3064-IGBT-GEVB is an isolated supply for IGBT drivers, providing the necessary stable voltage rails -7.5V/15V for an efficient switching - as well as an additional 7.5 V rail - over a wide input voltage range (6 Vdc to 18 Vdc). The converter is implemented as a primary side regulated flyback, with the feedback loop signal (1.25V) realized via an auxiliary winding regulated at 5V and a voltage divider. The design leverages the several merits of the NCV3064 regulator, enabling a low component count, compact and robust design. Among the features of this converter stand out – e.g. an internal temperature compensated reference, a controlled duty cycle oscillator with an active current limit circuit, driver and high current output switch. The board is realized with Automotive qualified parts and is pin compatible with commercial IGBT DC/DC supplies, provisioning a ready to use plug-in solutions for power applications.

Main features

- Core part – NCV3064 (automotive) / NCP3064 (industrial)
- Switching frequency 150 kHz
- Input Voltage 6-18 VDC
- Output Voltage -7.5V/7.5V/15V
- Operation mode DCM
- Output Current 50mA (for each branch)
- Efficiency at full load 67%
- Size 26.24 x 16.38 x 16.06 mm

Technical specifications

- Interwinding capacitance 7.8 pF
- Dielectric insulation 4000VAC
- Inductance 42µH
- Leakage inductance 390nH
- Safety standard according to IEC62368-1 / IEC61558-2-16

Target Applications & Reusability

- Isolated IGBT driver supply
- Automotive powertrain systems
- Automotive auxiliary power

Benefits for customers

- Simple, robust, low component count solution
- Stable performance across wide input voltage range (6 Vdc – 18 Vdc)
- Plug-in header for easy integration to boards
- AEC-Q qualified parts

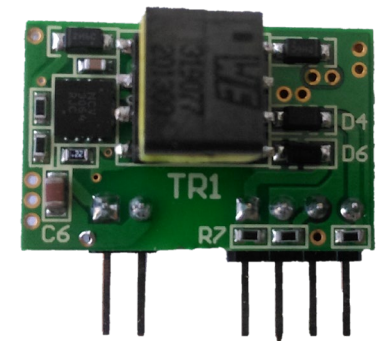
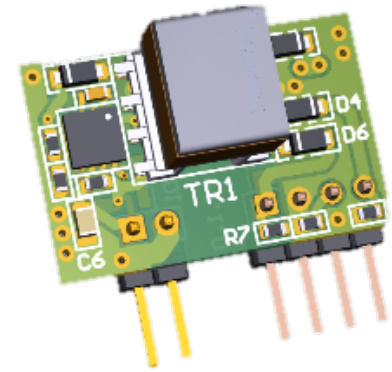
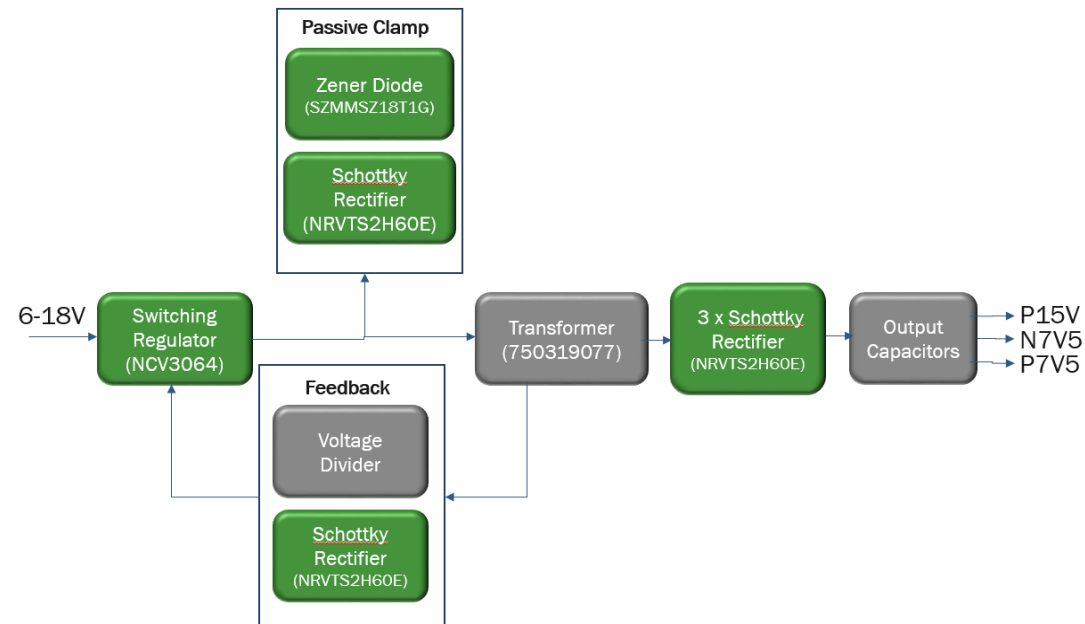

Specification

Parameters	Values
Input	
Voltage	6-18VDC
Current	400mA (Vin=6V), 125mA (Vin=18V)
Output	
Power	1.5W
Voltage	-7.5/7.5/15VDC
Current per branch	50mA
Total current	150mA
Efficiency at full load	67% (Vin=15V)
Temperature at full load	98 °C (Vin = 6V), 74.5 °C (Vin = 15V), 76 °C (Vin = 18V)
Control	
Core part	NCV3064
Topology	Flyback
Switching frequency	150kHz
Operation mode	DCM
Primary side peak current	1.1A
Construction	
Board size	26.24 x 16.38 x 16.06mm
Transformer	
Interwinding capacitance	7.8pF
Dielectric insulation	4000VAC
Inductance	42 μH
Leakage inductance	390nH
Safety standard	IEC62368-1 /IEC61558-2-16
Application	
Isolated IGBT driver supply, automotive powertrain systems, automotive auxiliary power	

Block diagram

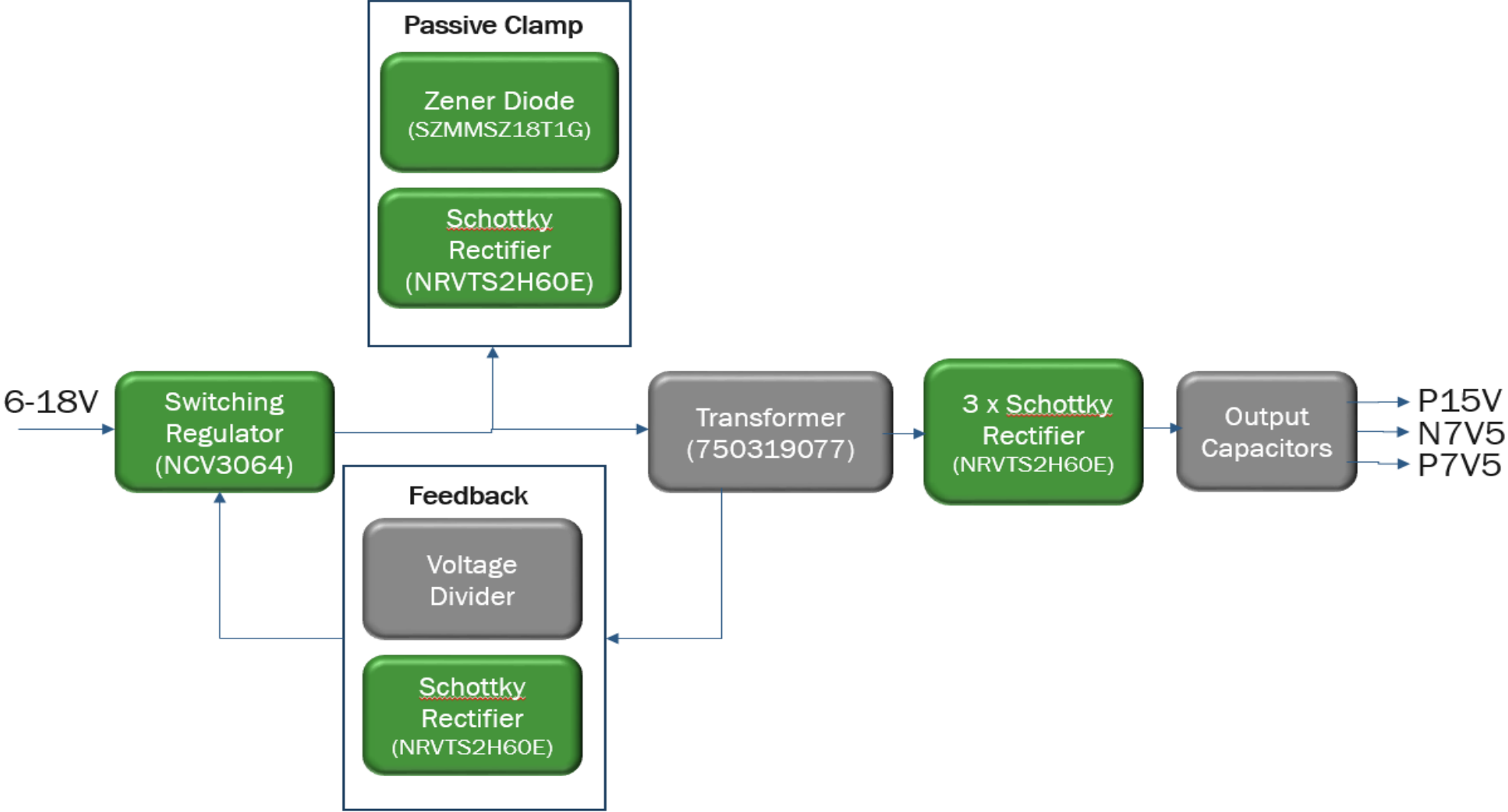

Layout and format factor

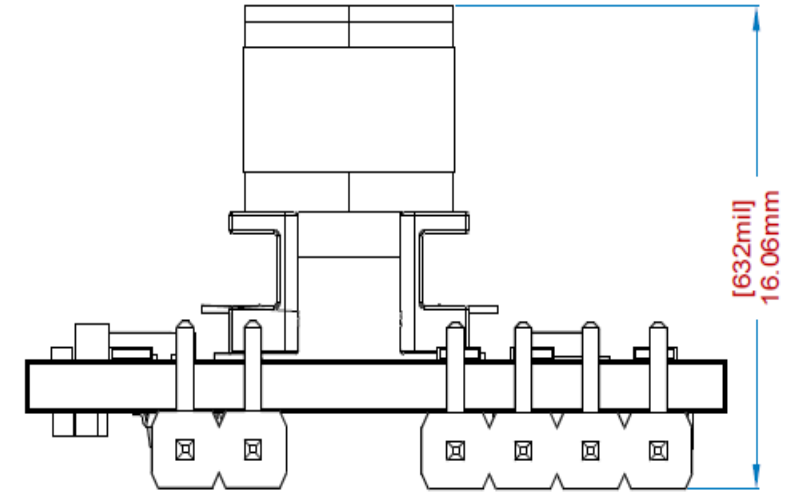
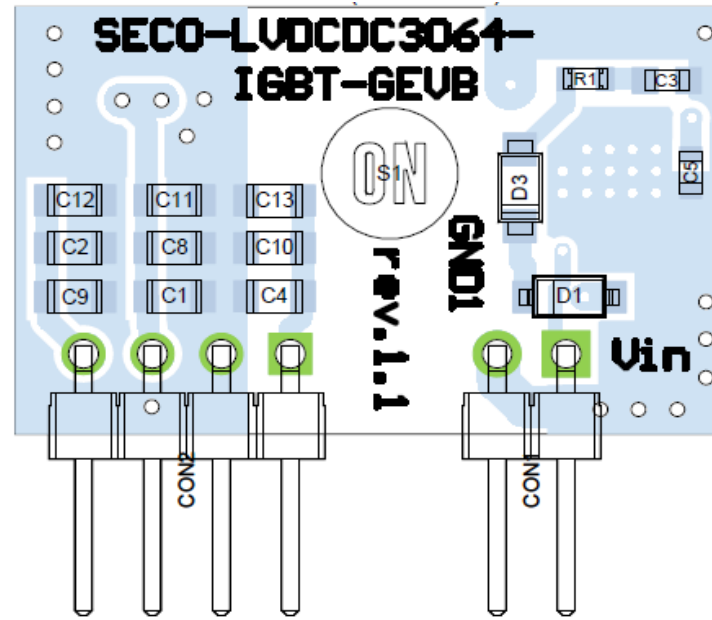
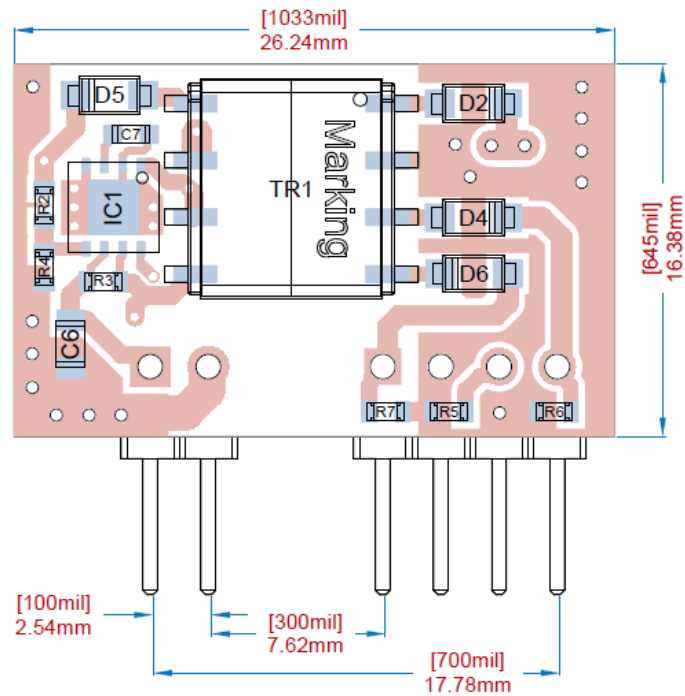

Header connector is pin compatible with commercial DC/DC isolated supply bricks.

The board is designed in two layers with size of 26.24x16.38x16.06mm

Schematic

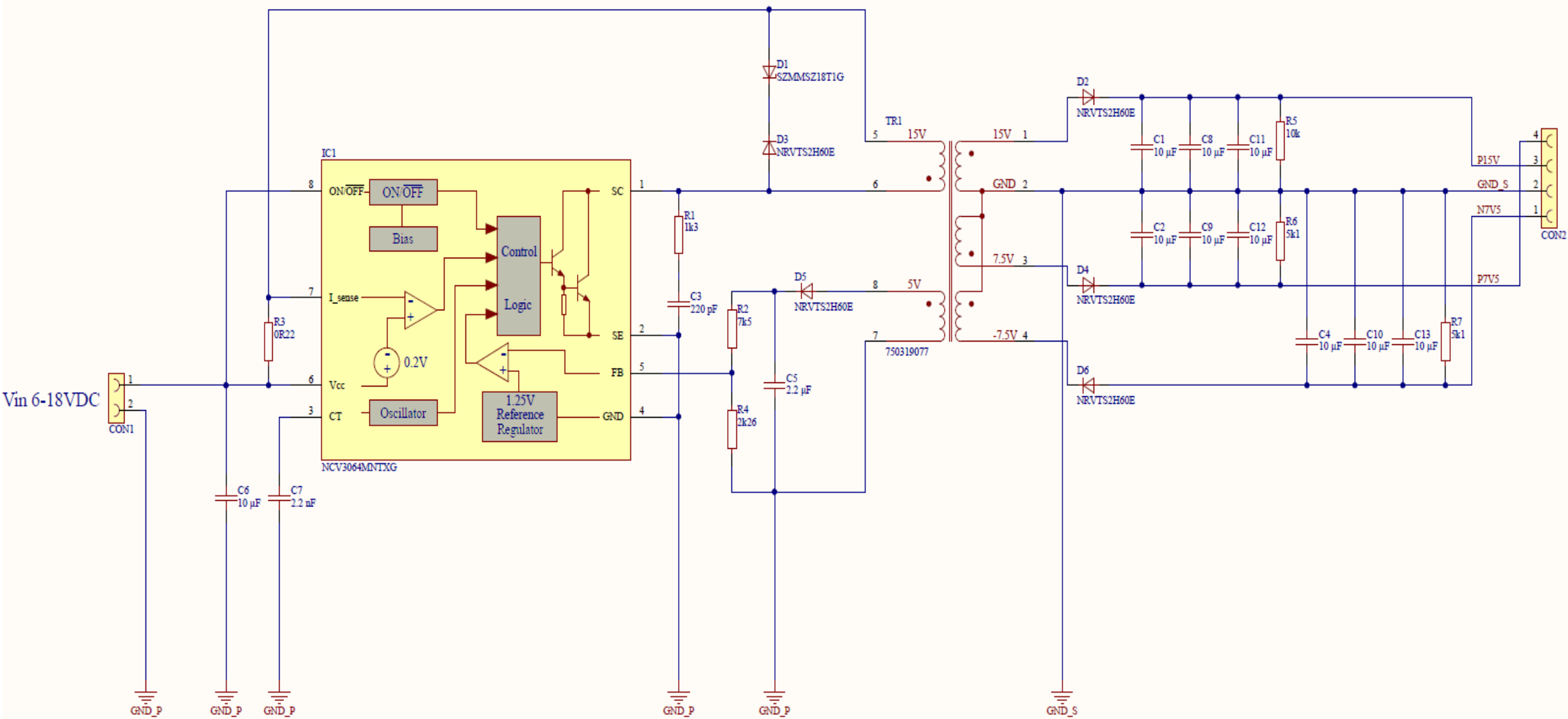

Test Reports

1. Output voltage at different loads and input voltages
2. Temperature performance
3. Cross regulation measurements
4. Output voltage ripple
5. Load transients
6. Line regulation
7. Efficiency



Output voltage

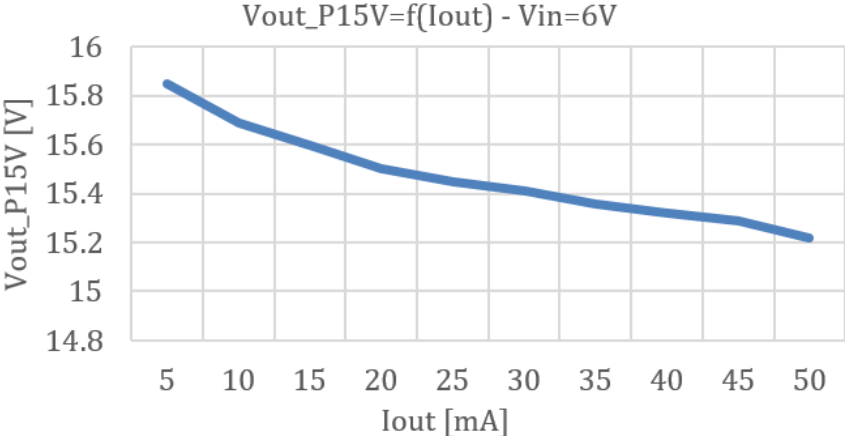

a)

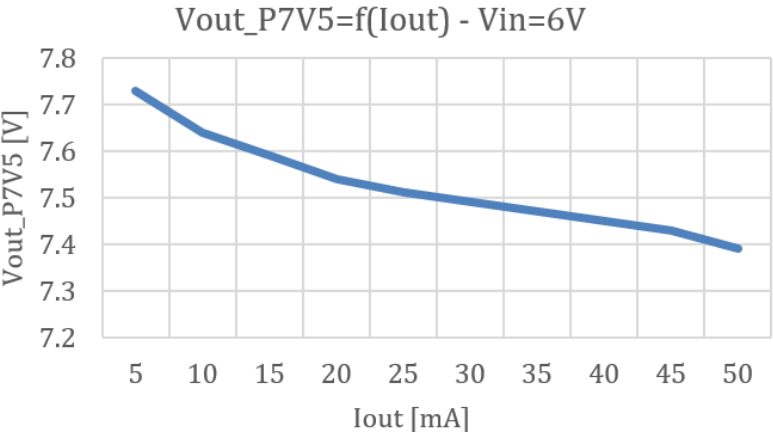

b)

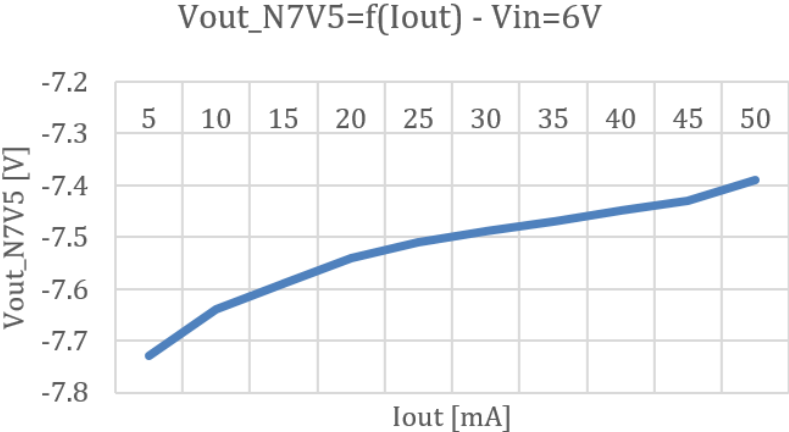

c)

Measurement of output voltage for load current and 6V input voltage:

- a) 15V branch
- b) 7.5V branch
- c) -7.5V branch



Output voltage

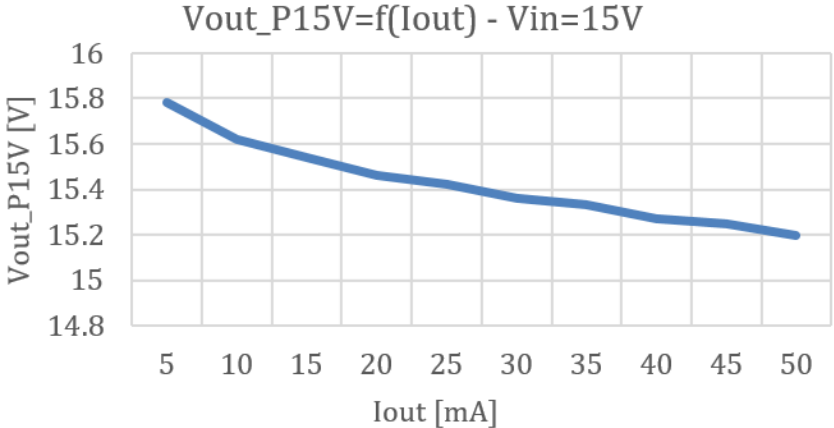

a)

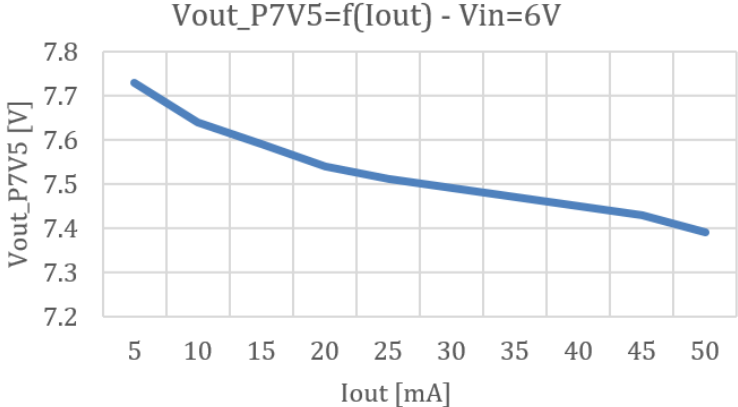

b)

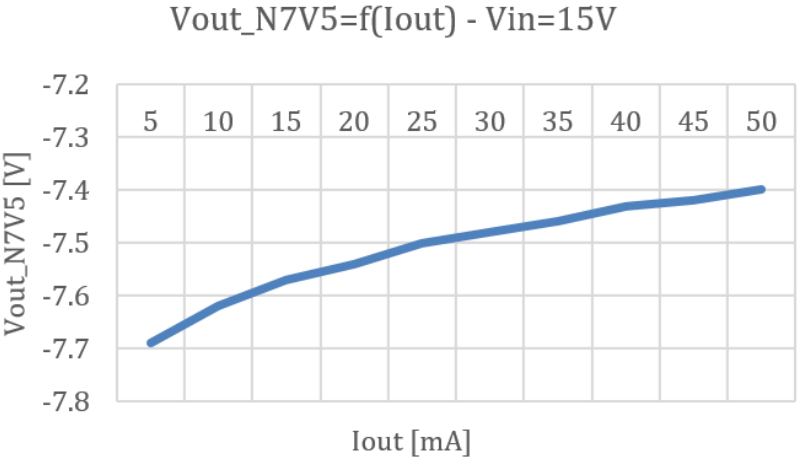

c)

Measurement of output voltage for load current and 15V input voltage:

- a) 15V branch
- b) 7.5V branch
- c) -7.5V branch



Cross regulation measurements

Vin=6V					
P7V5 full load (50mA), N7V5 and P15V no load		P7V5 no load, N7V5 and P15V full load (50mA)		P7V5 and N7V5 no load, P15V full load (50mA)	
Vout_P15V (V)	15.68	15.24		15.01	
Vout_P7V5 (V)	7.00	7.76		7.79	
Vout_N7V5 (V)	-7.64	-7.4		-7.79	
Vin=15V					
P7V5 full load (50mA), N7V5 and P15V no load		P7V5 no load, N7V5 and P15V full load (50mA)		P7V5 and N7V5 no load, P15V full load (50mA)	
Vout_P15V (V)	16.02	15.19		14.94	
Vout_P7V5 (V)	6.78	7.79		7.82	
Vout_N7V5 (V)	-7.72	-7.38		-7.82	
Vin=18V					
P7V5 full load (50mA), N7V5 and P15V no load		P7V5 no load, N7V5 and P15V full load (50mA)		P7V5 and N7V5 no load, P15V full load (50mA)	
Vout_P15V (V)	16.04	15.22		14.94	
Vout_P7V5 (V)	6.76	7.8		7.82	
Vout_N7V5 (V)	-7.73	-7.39		-7.82	

Output voltage ripple

	No load	50% load	100% load	100% load just on P15V branch
Vin=6V				
Vripple [%]	0.4	1	1.46	2.21
Vin=15V				
Vripple [%]	1.31	1.29	1.82	2.67
Vin=18V				
Vripple [%]	1.58	1.4	1.9	2.95

a)

	No load	50% load	100% load	100% load just on N7V5 branch
Vin=6V				
Vripple [%]	0.38	2.28	2.69	4.55
Vin=15V				
Vripple [%]	1.43	2.41	3.24	4.77
Vin=18V				
Vripple [%]	1.53	2.54	4.05	4.95

b)

Output voltage ripple for different conditions:
 a) P15V branch, b) N7V5 branch.

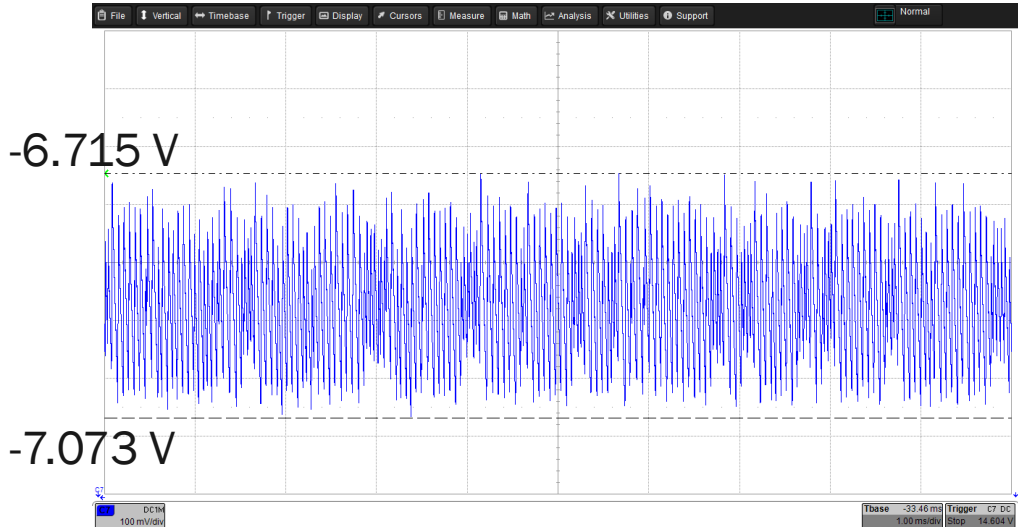
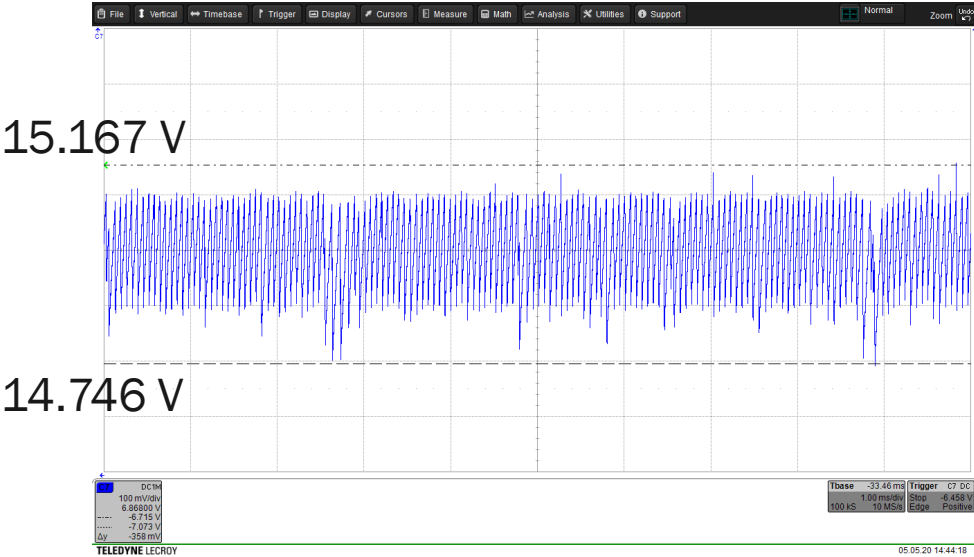

Output voltage ripple for the worst cases: a) P15V branch – Vin = 18V, just P15V is fully loaded, b) N7V5 branch – Vin = 18V just N7V5 is fully loaded



Shortcircuit measurement

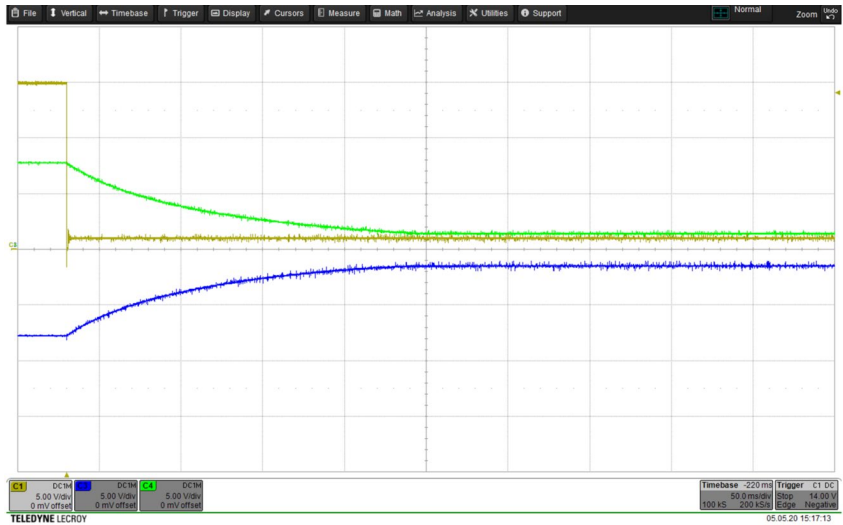

a)

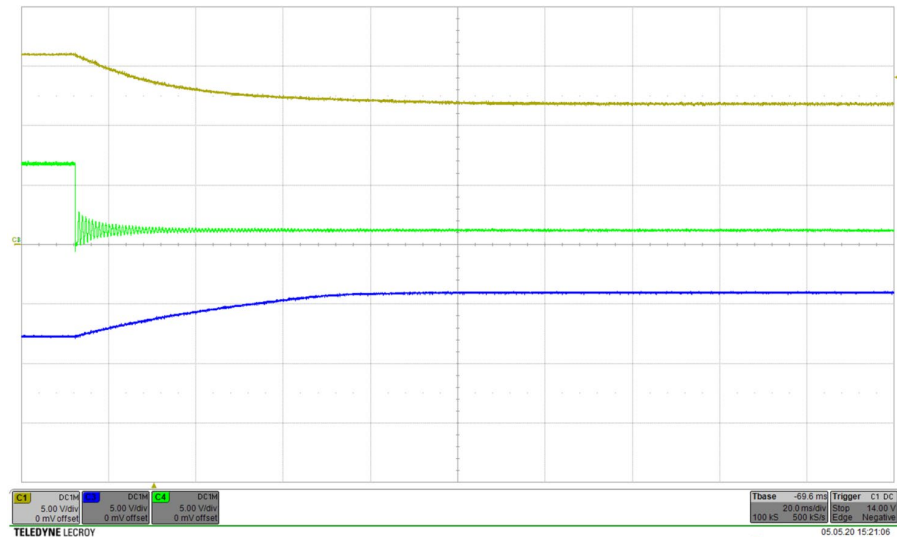

c)

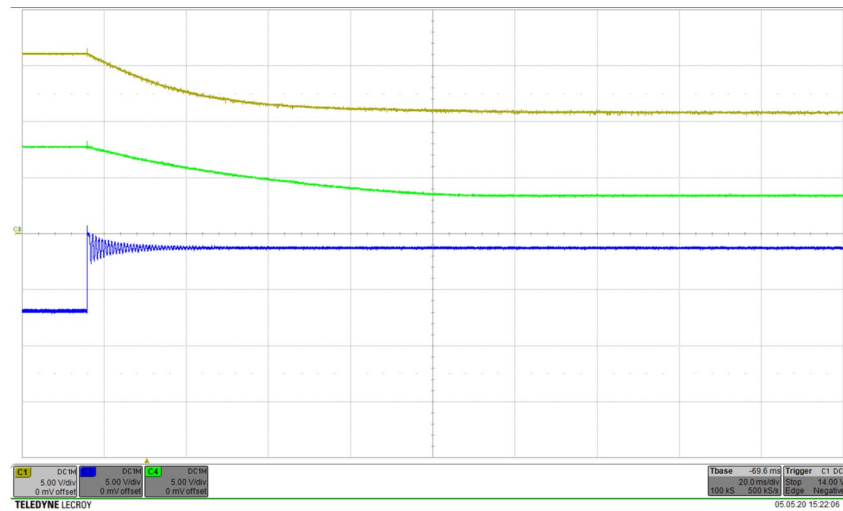

b)

Short circuit tests (yellow - P15V, green – P7V5, blue – N7V5):

a) Short circuit on P15V

b) Short circuit on N7V5

c) Short circuit on P7V5

Load transient and line regulation

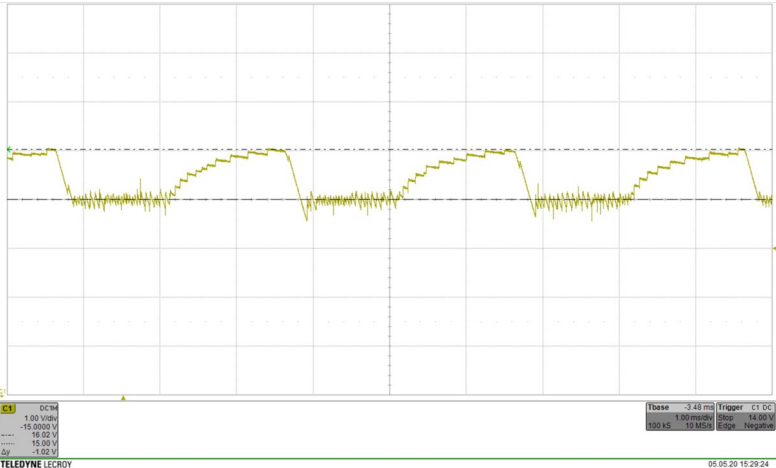

a)

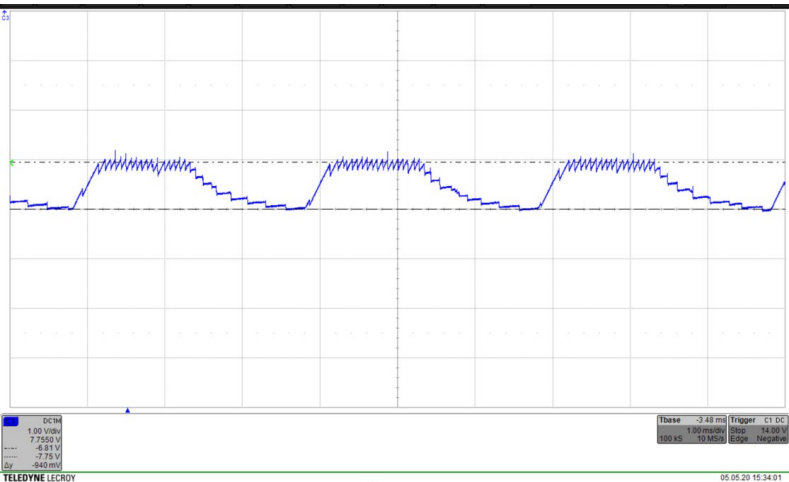

b)

Load transients measurement: a) P15V branch, b) N7V5 branch

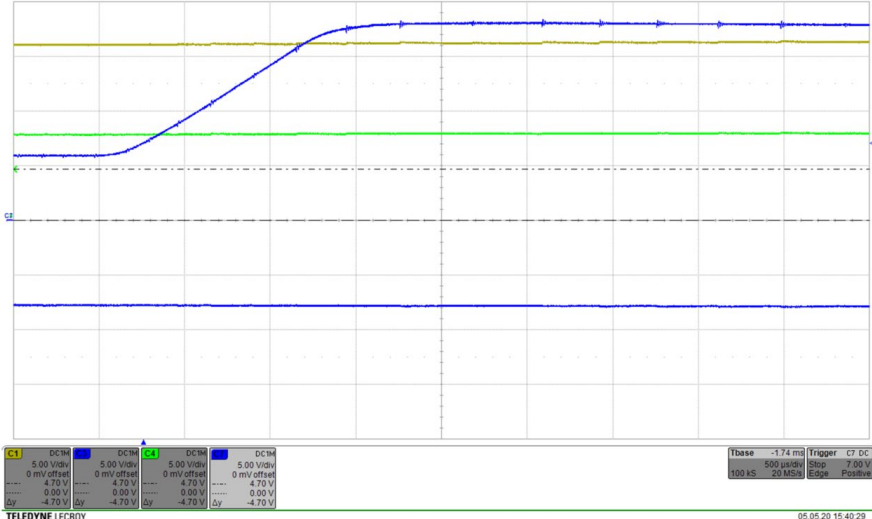

a)

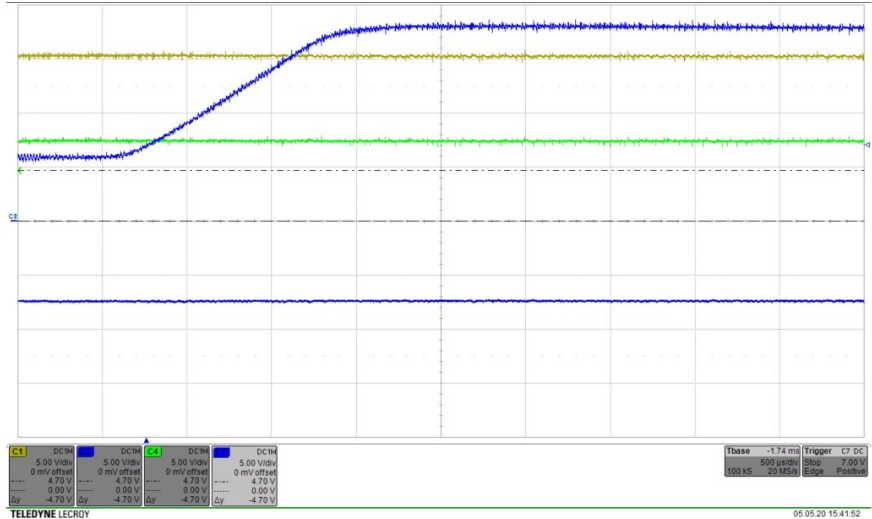

b)

Line regulation measurement (blue – Vin, N7V5, green – P7V5, yellow – P15V): a) no load condition, b) full load condition. Frame: 1 ms



Efficiency

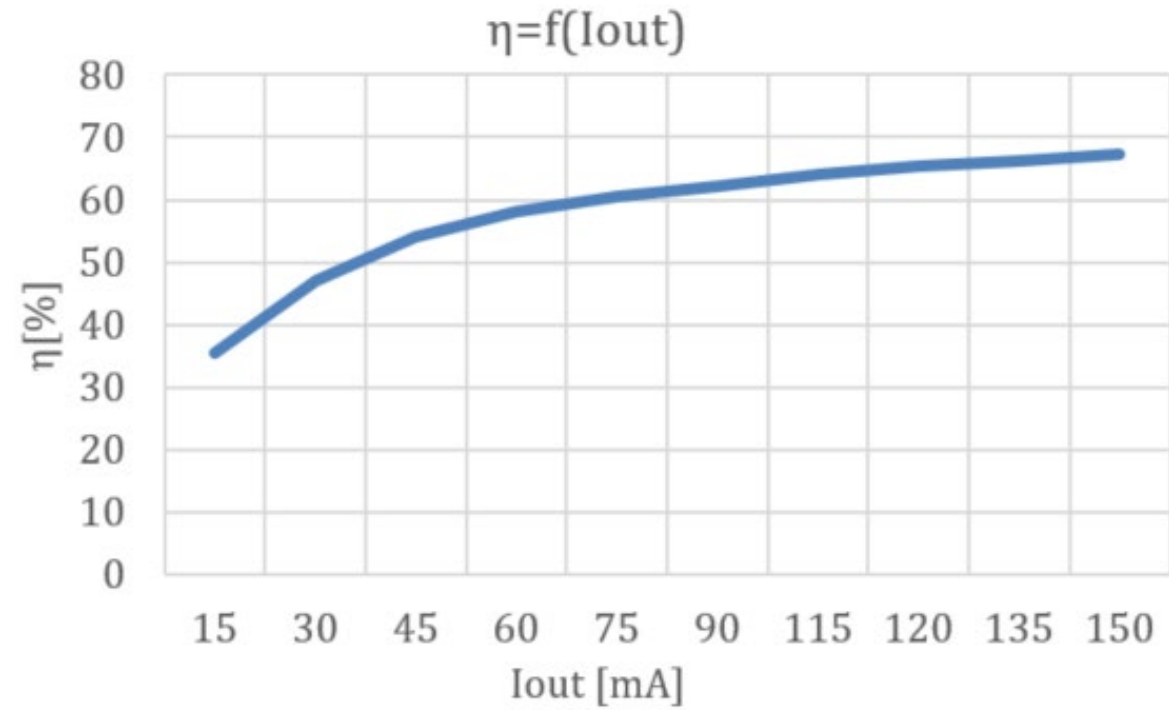

Figure 11. Efficiency for different output load

Transformer design

The transformer is developed according to IEC62368-1 /IEC61558-2-16 safety standards and working in Discontinuous Current Mode (DCM).

CUSTOMER TERMINAL Sn 96%, Ag 4%	RoHS Yes	LEAD(Pb)-FREE Yes	more than you expect
---	--------------------	-----------------------------	----------------------

TERM. NO.'s FOR REF. ONLY

CHAMFERS LOCATE TERM.'s #1 & 8

DOT LOCATES TERM. #1

LOT CODE & DATE CODE

AREA REPRESENTS TERMINAL PAD DIMENSIONS

REFERENCE LAND SIZE

CUSTOMER TO DETERMINE LAND LAYOUT

ELECTRICAL SPECIFICATIONS @ 25° C unless otherwise noted:

PARAMETER	TEST CONDITIONS	VALUE
D.C. RESISTANCE	6-5 @20°C	0.195 ohms ±10%
D.C. RESISTANCE	1-2 @20°C	1.300 ohms ±10%
D.C. RESISTANCE	2-3 @20°C	0.700 ohms ±10%
D.C. RESISTANCE	2-4 @20°C	0.700 ohms ±10%
D.C. RESISTANCE	8-7 @20°C	0.550 ohms ±10%
INDUCTANCE	6-5 10kHz, 100mV, Ls	42.00µH ±10%
SATURATION CURRENT	6-5 20% rolloff from initial	1.25A typ.
LEAKAGE INDUCTANCE	6-5 tie(1+2+3+4, 8+7), 100kHz, 100mV, Ls	390nH typ., 500nH max.
INTERWINDING CAPACITANCE	4-5 tie(1+2+3+4), 100kHz, 10mVAC, Cs	7.8pF typ.
DIELECTRIC	5-4 tie(6+7, 1+2+3+4), 4000VAC, 1 second	4000VAC, 1 minute
TURNS RATIO	(1-2):(6-5)	1.43:1, ±1%
TURNS RATIO	(6-5):(3-2)	1.4:1, ±1%
TURNS RATIO	(6-5):(2-4)	1.4:1, ±1%
TURNS RATIO	(6-5):(8-7)	2:1, ±1%

GENERAL SPECIFICATIONS:
OPERATING TEMPERATURE RANGE: -40°C to +125°C including temp rise.

PRI 12-18Vdc 150kHz

AUX 5V - 0.005 A

SEC 15 V - 0.05 A

SEC 7.5 V - 0.05 A

SEC 7.5 V - 0.05 A

Wire insulation & RoHS status not affected by wire color. Wire insulation color may vary depending on availability.

DFM	SP	Packaging Specifications	Tolerances unless otherwise specified:	DRAWING TITLE	PART NO.
DATE	3/5/2020	Method: Tape & Reel	Angles: ±1°	TRANSFORMER	750319077
ENG	WJK	PKG-0987	Decimals: ±.005 [.13]		
REV.	00		Fractions: ±1/64		
DATE	3/27/2020		Footprint: ±.005 [.13]		SPECIFICATION SHEET 1 OF 1



#	Designator	Comment	Description	Manufacturer	Manufacturer Part Number
1.	C1, C2, C4, C6, C8, C9, C10, C11, C12, C13	10 µF	SMD Multilayer Ceramic Capacitor, 10 µF, 25 V, 0805 [2012 Metric], ± 10%, X7S, CGA Series	TDK	CGA4J1X7S1E106K125A E
2.	C3	220 pF	Multilayer Ceramic Capacitors MLCC - SMD/SMT 50V 220pF 0603 X7R 10% AEC-Q200	KEMET	C0603C221K5RACAUTO
3.	C5	2.2 µF	GRT188C81E225KE13D - SMD Multilayer Ceramic Capacitor, 2.2 µF, 25 V, 0603 [1608 Metric], ± 10%, X6S, GRT Series, Murata	Murata	GRT188C81E225KE13D
4.	C7	2.2 nF	Multilayer Ceramic Capacitors MLCC - SMD/SMT CGA 0603 50V 2200pF X7R 10% AEC-Q200	TDK	CGA3E2X7R1H222K080A A
5.	CON1	613 002 110 21	PTH right angle male header 2 pins 2.54 mm pitch Würth Elektronik	Würth Elektronik	61300211021
6.	CON2	61300411021	WR-PHD 2.54 mm THT Angled Pin Header 1x4	Würth Elektronik	61300411021
7.	D1	SZMMSZ18T1G	Zener Single Diode, 18 V, 500 mW, SOD-123, 5 %, 2 Pins, 150 °C	ON Semiconductor	SZMMSZ18T1G
8.	D2, D3, D4, D5, D6	NRVTS2H60E	Trench Schottky Rectifier, Very Low Leakage 2A, 60V ON Semiconductor	ON Semiconductor	NRVTS2H60ESFT1G
9.	IC1	NCV3064MNTXG	Buck / Boost / Inverting Converter, Switching Regulator, 1.5 A, with On/Off Function	ON Semiconductor	NCV3064MNTXG
10.	R1	1k3	SMD thick film resistor 1k3 0603 1% 100 mW Panasonic	Panasonic	ERJ3EKF1301V
11.	R2	7k5	SMD thick film resistor 7k5 0603 1% 100 mW Panasonic	Panasonic	ERJ3EKF7501V
12.	R3	0R22	SMD Current Sense Resistor, 0.22 ohm, ERJ3R Series, 0603 [1608 Metric], 100 mW, ± 1%, Thick Film, Panasonic	Panasonic	ERJ3RQFR22V
13.	R4	2k26	SMD thick film resistor 2k26 0603 1% 100 mW Panasonic	Panasonic	ERJ3EKF2261V
14.	R5	10k	SMD thick film resistor 10k 0603 1% 100 mW Panasonic	Panasonic	ERJ3EKF1002V
15.	R6, R7	5k1	SMD thick film resistor 5k1 0603 1% 100 mW Panasonic	Panasonic	ERJ3EKF5101V
16.	TR1	750319077	Custom transformer Flyback converter Uin=15V Uout1=15V Uout2=-7.5V Uout3=7.5V Uout4_aux=5V	Würth Elektronik	750319077



FOR ENERGY EFFICIENT INNOVATIONS

www.onsemi.com

THINK ON.

IGBT isolated driver supply 3W 15V/-7.5

SECO-LVDCDC-3064-IGBT-GEVB

Public Information

