

Belt Starter Generator (BSG) Demo

48V Power module Solutions

High efficiency, high power density solutions for 48V BSG/ISG application based on our unique 48V automotive transfer molded APM17M power module technology.

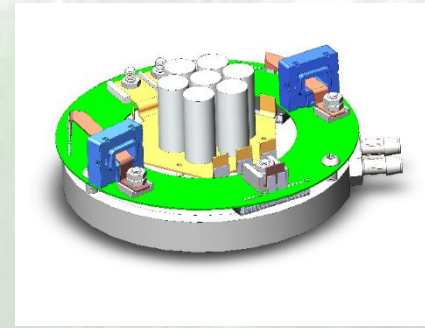

Block Diagram

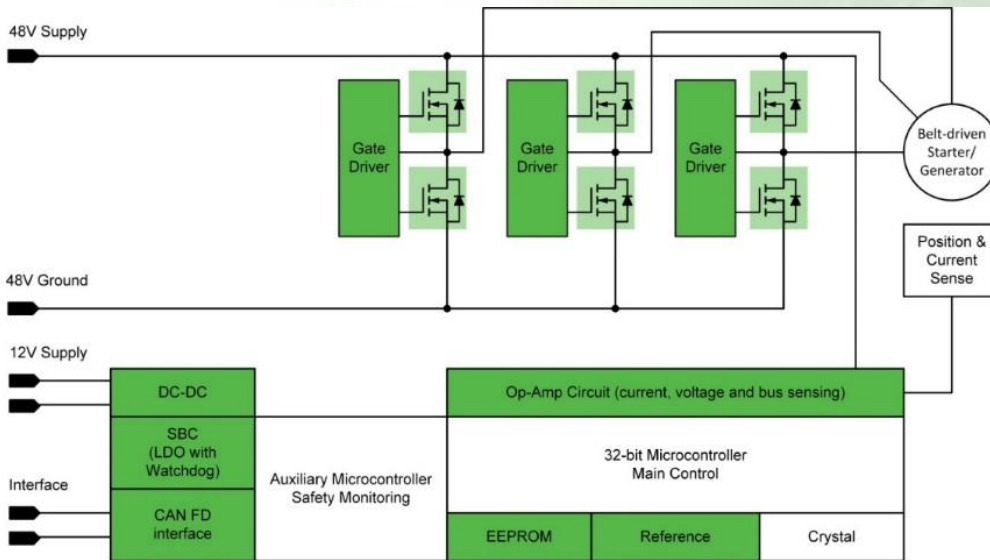

Performances

- Reduce overall system size and cost
- Half-bridge automotive power modules available in multiple configurations
- Very Low junction-sink thermal resistance
- Highly integrated compact design
- Low electrical resistance and Very Low stray inductance
- Better EMI and electrical isolation
- Easy and reliable installation

Applications	~15kw BSG 3Φ Motor	~25kw 48V B(i)SG 3Φ Motor	~15kw BSG 6Φ Motor	~25kw 48V B(i)SG 6Φ Motor
48V MHEV	80V / 100V	80V / 100V	80V / 100V	80V / 100V

