

# Test Procedure for MC34063 Boost Regulator Demonstration Board

ON Semiconductor



11/11/2003

**Table 1: Required Equipment**

Three Black Test Leads	Three Red Test Leads	100mA load (or 33 ohm, 1W resistor)
12 VDC Power Supply	MC34063 Boost Regulator	Digital Multimeter
Four Alligator Clips		

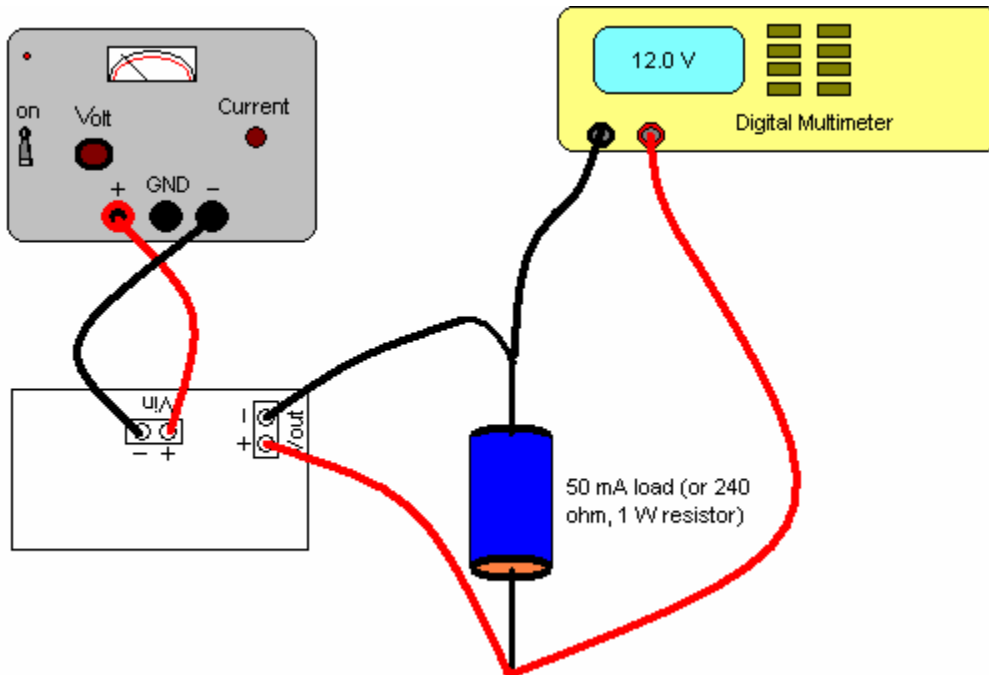

Figure 1: Test Procedure for MC34063

1. Attach 50 mA load (or 240 ohm, 1 W resistor) to connector P802.
2. Attach 3.3 VDC source to connector P801 – observe polarity.
3. Turn on 3.3 VDC source.
4. Measure DC output voltage at connector P802.
5. DC voltage should be 12.0V +/- 0.3V.
6. Remove load.
7. Measure DC output voltage at connector P802.
8. DC voltage should be 12.0V +/- 0.3V.
9. Remove 3.3 VDC source and disconnect load – test complete.