



## ADS-93X Timing Generator Board User's Manual

ON Semiconductor®

<http://onsemi.com>

### Eval Board User's Manual

#### Timing Generator Board Description

This Timing Generator Board is designed to be part of a two-board set, used in conjunction with an ON Semiconductor CCD Imager Evaluation Board. ON Semiconductor offers a variety of CCD Imager Boards that have been designed to operate with this Timing Generator Board. For more information on the available Imager Evaluation Boards, see the ON Semiconductor contact information at the end of this document.

The Timing Generator Board generates the timing signals necessary to operate Truesense Imaging Imager Boards, and also provides the power required by these Imager Boards via the board interface connector (J4). In addition, the Timing Generator Board performs the signal processing and digitization of the analog output from the Imager Board. The analog output of the Imager Board is connected to the Timing Generator Board via coaxial cable.

The Timing Generator Board contains an Altera Programmable Logic Device (PLD) that can be In-System-Programmed (ISP) with code that is imager specific. This provides flexibility to operate many different Imager Boards with the same Timing Generator Board.

The Timing Generator Board has a digital Input interface to the Altera device that can be used to support various modes of operation depending on imager specific Altera code.

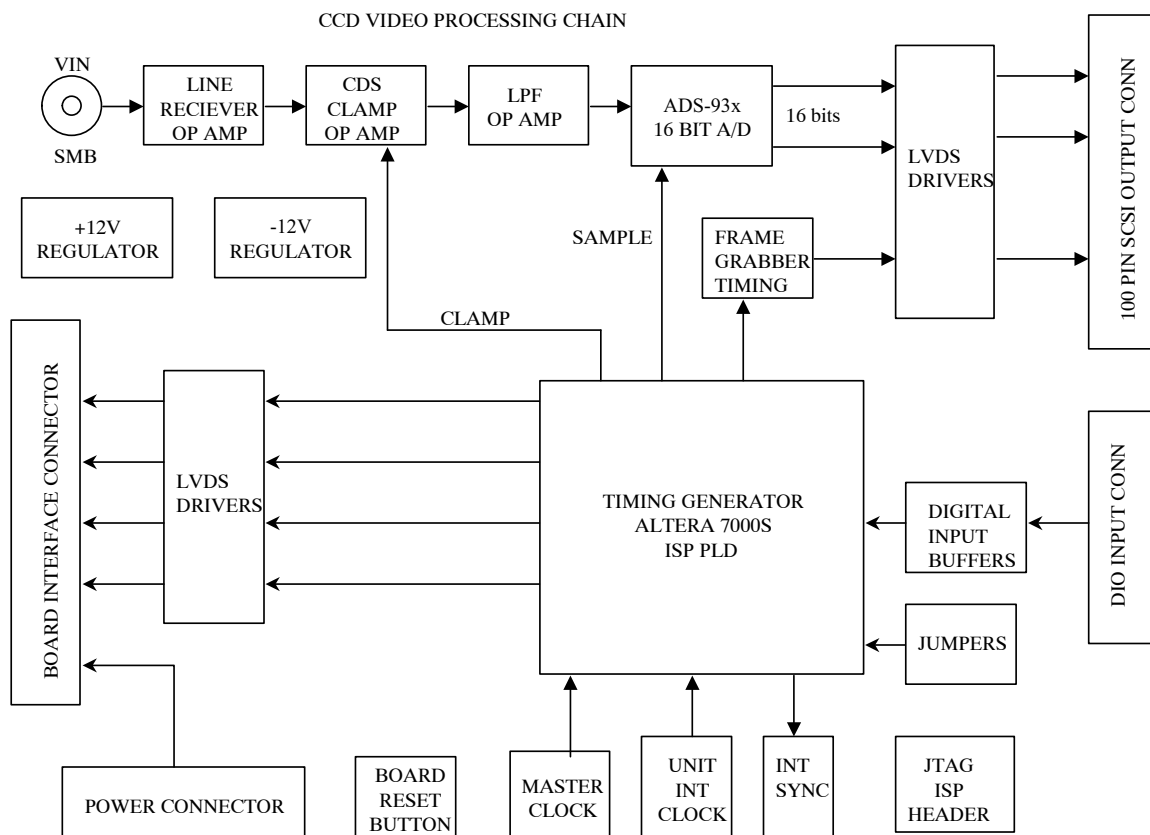

Figure 1. Generator Board Block Diagram

**TIMING GENERATOR BOARD INPUT REQUIREMENTS**

**Table 1. POWER SUPPLY INPUT REQUIREMENTS**

Power Supplies	Minimum	Typical	Maximum	Units
+5 V Supply	4.9	5	5.1	V
		500		mA
-5 V Supply	-5.1	-5	-4.9	V
		150		mA
VPLUS Supply	18	20	24	V
		25		mA
VMINUS Supply	-21	-20	-18	V
		15		mA

**TIMING GENERATOR BOARD ARCHITECTURE OVERVIEW**

The following sections describe the functional blocks of the Timing Generator Board. See Figure 1 for an overall block diagram of the Timing Generator Board.

**Power Connector**

This connector provides the necessary power supply inputs to the Timing Generator Board. The connector also provides the power needed by the CCD Imager Boards. The Timing Generator Board simply routes these power supplies from the power connector to the board interface connector. Table 1 shows the power supply requirements for the timing generator board. This is not the total power requirement since this board is always used in conjunction with an image sensor board. The current requirements for the image sensor board are contained in its manual, and need to be added to the values listed in Table 1 to arrive at the total system power requirement. The “VPLUS Supply” voltage value can vary from 20 to 24 volts depending on the specific imager board. Consult the image sensor board manual for the required value.

**Power Supply Filtering**

Power supplied to the board is de-coupled and filtered with ferrite beads and capacitors in order to suppress noise.

**Table 2. TIMING BOARD CLOCK RATES**

Timing Board PN	Master Clock	Pixel Clock (Max)
3E8290	48 MHz	3 MHz

**Unit Integration Clock**

The unit integration clock is used as a means for varying the integration time. The clock circuit consists of a 555 timer configured to oscillate at a frequency of 100 Hz. The output of this circuit, the INTEGRATE\_CLK, has a 10 ms period, which is used by the Altera PLD as the unit integration time. When the Timing Generator Board is configured to operate in the internal integration mode, the integration time is

For best noise performance, linear power supplies should be used to provide power to the boards.

**Voltage Regulators**

The operational amplifiers in the CCD video processing chain require  $\pm 12$  V power supplies. These power supply voltages are regulated down from the VPLUS and VMINUS supplies input to the Timing Generator Board.

**Power-On Clear / Board Reset**

The Altera Programmable Logic Device (PLD) resets and initializes the board on power-up, or when the BOARD RESET button is pressed. The default configuration is defined separately for each particular CCD Image Sensor, and is detailed in the associated Altera Code Timing Specification.

**Master Clock**

The master clock is used to generate the pixel rate clocks. The pixel rate timing signals operate at a frequency that is divided down from the master clock frequency. The exact pixel rate frequency is Altera code dependent, but is typically equal to 1/16 the frequency of the master clock.

controlled by the Timing Generator Board and will be a multiple of this unit integration time. The actual integration time is dependent on how the integration control lines on the digital input connector are configured, as well as on how the Altera PLD is programmed.

**Integration Sync Output Connector**

This output provides a signal that is high during the integration time period. This signal can be used to synchronize an external shutter or LED light source with the integration time period.

**Digital Input Connector (Remote Digital Input Control)**

The digital input connector can be used to input control signals to the evaluation board. These control signals can be used to adjust the operating mode of the evaluation board. The functions of the digital inputs depend on what code the Altera device is programmed with. This is an optional feature. No external digital inputs are required for board operation.

The digital input control lines to the board are buffered. The input pins to the buffer IC's are weakly held low by pull down resistors to GND. Therefore, with no digital inputs, the default level of the Timing Generator Board control lines is all zeros.

A three wire serial interface is also provided on the input connector. This interface consists of three lines, a serial clock, serial data, and a serial load signal. The serial interface is provided as an alternate way to adjust the operating condition of the Timing Generator Board if the Altera device is programmed with code to support this feature.

**Jumpers**

There are four jumpers on the board that can be used to adjust the operating mode of the Timing Generator Board. The functions of the jumpers depend on how the Altera device is programmed, and is detailed in the associated Altera Code Timing Specification.

**JTAG Header**

This 10-pin header provides the user with the ability to reprogram the Altera PLD in place via Altera's BYTEBLASTER programming hardware.

**Timing Generator PLD**

The Programmable Logic Device (PLD) is an Altera 7000S series part. This device is In System Programmable (ISP) via a 10-pin JTAG header located on the board. In this way, the Altera device is programmed with imager specific code to operate the Imager Board to which the Timing Generator Board will be connected.

The Timing Generator PLD controls the overall flow of the evaluation board operation. The PLD outputs include the CCD clocks signals, analog processing timing signals, and Frame Grabber synchronization signals.

**LVDS Drivers**

Timing signals are sent to the Imager Board via the board interface connector using Low Voltage Differential Signaling (LVDS) drivers. LVDS combines high-speed connectivity with low noise and low power.

**Board Interface Connector**

This 80-pin connector provides both the timing signals and the necessary power to the CCD Imager Boards from the Timing Generator Board.

**CCD Video Processing Chain**

The CCD video signal from the Imager Board is input to the Timing Generator Board via the SMB coaxial connector. The coaxial cable is terminated with a resistor and is then buffered by a receiver op-amp with a gain of 1.25. Next the video signal is clamped to ground, effectively performing the first half of the correlated double sampling (CDS) function. Finally the video signal is passed through a low pass filter before being input to the 16-bit A/D converter. The A/D sample signal completes the CDS function and converts the signal to digital information.

**ADS-93X 16-Bit A/D Converter**

The Timing Generator Board supports the 16 bit ADS-93X family of convertors offered by Datel Inc.

There are several variants in the ADS-93X family. The Timing Generator Board is populated differently depending on which convertor is being used.

**Table 3. TIMING BOARD CONFIGURATION OPTIONS**

Timing Board PN	Datel A/D PN	Sampling Rate	Bit Depth	Channels
3E8290	ADS-933MC	3 MSPS	16	1

**Output Connector**

The output connector interfaces directly to the National Instruments PCI-1424 framegrabber. The output connector provides a single channel of 16 bit output data in LVDS

differential format. The connector also provides the three necessary PCI-1424 frame grabber synchronization signals in LVDS differential format.

# EVBUM2252/D

## CONNECTOR ASSIGNMENTS AND PINOUTS

### SMB Connector J5

J5 allows connection of the VOUT\_CCD video signal from the CCD Imager Boards.

**Table 4. DIGITAL INPUT CONNECTOR J4**

Pin	Assignment	Function	Pin	Assignment
1	SDATA	SERIAL PORT	2	GND
3	SCLOCK	SERIAL PORT	4	GND
5	SLOAD	SERIAL PORT	6	GND
7	DIO15	Altera Code Dependent	8	GND
9	DIO14	Altera Code Dependent	10	GND
11	DIO13	Altera Code Dependent	12	GND
13	DIO12	Altera Code Dependent	14	GND
15	DIO11	Altera Code Dependent	16	GND
17	DIO10	Altera Code Dependent	18	GND
19	DIO9	Altera Code Dependent	20	GND
21	DIO8	Altera Code Dependent	22	GND
23	DIO7	Altera Code Dependent	24	GND
25	DIO6	Altera Code Dependent	26	GND
27	DIO5	Altera Code Dependent	28	GND
29	DIO4	Altera Code Dependent	30	GND
31	DIO3	Altera Code Dependent	32	GND
33	DIO2	Altera Code Dependent	34	GND
35	DIO1	Altera Code Dependent	36	GND
37	DIO0	Altera Code Dependent	38	GND
39	NO CONNECT	N/A	40	GND

**Table 5. BOARD INTERFACE CONNECTOR J3**

Pin	Assignment	Pin	Assignment
1	N.C.	2	N.C.
3	AGND	4	AGND
5	TIMING_OUT11+	6	TIMING_OUT11-
7	AGND	8	AGND
9	TIMING_OUT10+	10	TIMING_OUT10-
11	AGND	12	AGND
13	TIMING_OUT9+	14	TIMING_OUT9-
15	AGND	16	AGND
17	TIMING_OUT8+	18	TIMING_OUT8-
19	AGND	20	AGND
21	TIMING_OUT7+	22	TIMING_OUT7-
23	AGND	24	AGND
25	TIMING_OUT6+	26	TIMING_OUT6-
27	AGND	28	AGND
29	TIMING_OUT5+	30	TIMING_OUT5-

**Table 5. BOARD INTERFACE CONNECTOR J3**

Pin	Assignment	Pin	Assignment
31	AGND	32	AGND
33	TIMING_OUT4+	34	TIMING_OUT4-
35	AGND	36	AGND
37	TIMING_OUT3+	38	TIMING_OUT3-
39	AGND	40	AGND
41	TIMING_OUT2+	42	TIMING_OUT2-
43	AGND	44	AGND
45	TIMING_OUT1+	46	TIMING_OUT1-
47	N.C.	48	N.C.
49	AGND	50	AGND
51	N.C.	52	N.C.
53	VMINUS_MTR	54	VMINUS_MTR
55	N.C.	56	N.C.
57	AGND	58	AGND
59	TIMING_OUT0+	60	TIMING_OUT0-
61	-5 V_MTR	62	-5 V_MTR
63	N.C.	64	N.C.
65	AGND	66	AGND
67	N.C.	68	N.C.
69	+5 V_MTR	70	+5 V_MTR
71	N.C.	72	N.C.
73	AGND	74	AGND
75	N.C.	76	N.C.
77	VPLUS_MTR	78	VPLUS_MTR
79	N.C.	80	N.C.

**Table 6. INTEGRATE SYNC CONNECTOR J1**

Pin	Assignment	Function
1	INTEGRATE	Signal is High during Integration Time Period
2	AGND	Ground

**Table 7. POWER CONNECTOR J2**

Pin	Assignment
1	VMINUS
2	AGND
3	VPLUS
4	AGND
5	-5 V_MTR
6	AGND
7	+5 V_MTR
8	AGND

**Table 8. JUMPER SELECTS P[4..1]**

Jumper	Pin	Assignment	Pin	Assignment	Pin	Assignment	Function
P1	1	VCC	2	JMP0	3	AGND	Altera Code Dependent
P2	1	VCC	2	JMP1	3	AGND	Altera Code Dependent
P3	1	VCC	2	JMP2	3	AGND	Altera Code Dependent
P4	1	VCC	2	JMP3	3	AGND	Altera Code Dependent

**Table 9. JTAG CONNECTOR P5**

Pin	Assignment
1	TCK
2	AGND
3	TDO
4	+5 V_MTR
5	TMS
6	N.C.
7	N.C.
8	N.C.
9	TDI
10	AGND

**Table 10. OUTPUT CONNECTOR J6**

Pin	Assignment	Signal Level	Pin	Assignment	Signal Level
1	AOUT0+	LVDS	2	AOUT0-	LVDS
3	AOUT1+	LVDS	4	AOUT1-	LVDS
5	AOUT2+	LVDS	6	AOUT2-	LVDS
7	AOUT3+	LVDS	8	AOUT3-	LVDS
9	AOUT4+	LVDS	10	AOUT4-	LVDS
11	AOUT5+	LVDS	12	AOUT5-	LVDS
13	AOUT6+	LVDS	14	AOUT6-	LVDS
15	AOUT7+	LVDS	16	AOUT7-	LVDS
17	AOUT8+	LVDS	18	AOUT8-	LVDS
19	AOUT9+	LVDS	20	AOUT9-	LVDS
21	AOUT10+	LVDS	22	AOUT10-	LVDS
23	AOUT11+	LVDS	24	AOUT11-	LVDS
25	AOUT12+	LVDS	26	AOUT12-	LVDS
27	AOUT13+	LVDS	28	AOUT13-	LVDS
29	AOUT14+	LVDS	30	AOUT14-	LVDS
31	AOUT15+	LVDS	32	AOUT15-	LVDS
33	N.C.		34	N.C.	
35	N.C.		36	N.C.	
37	N.C.		38	N.C.	
39	N.C.		40	N.C.	
41	FRAME+		42	FRAME-	
43	LINE+		44	LINE-	

**Table 10. OUTPUT CONNECTOR J6**

Pin	Assignment	Signal Level	Pin	Assignment	Signal Level
45	N.C.		46	N.C.	
47	N.C.		48	N.C.	
49	PIXEL+		50	PIXEL-	
51	N.C.		52	N.C.	
53	N.C.		54	N.C.	
55	N.C.		56	N.C.	
57	N.C.		58	N.C.	
59	N.C.		60	N.C.	
61	N.C.		62	N.C.	
63	N.C.		64	N.C.	
65	N.C.		66	N.C.	
67	N.C.		68	N.C.	
69	N.C.		70	N.C.	
71	N.C.		72	N.C.	
73	N.C.		74	N.C.	
75	N.C.		76	N.C.	
77	N.C.		78	N.C.	
79	N.C.		80	N.C.	
81	N.C.		82	N.C.	
83	N.C.		84	N.C.	
85	N.C.		86	N.C.	
87	N.C.		88	N.C.	
89	N.C.		90	N.C.	
91	N.C.		92	N.C.	
93	N.C.		94	N.C.	
95	N.C.		96	N.C.	
97	N.C.		98	N.C.	
99	AGND		100	AGND	

**Warnings and Advisories**

ON Semiconductor is not responsible for customer damage to the Timing Board or Imager Board electronics. The customer assumes responsibility and care must be taken when probing, modifying, or integrating the Truesense Imaging Evaluation Board Kits.

When programming the Timing Board, the Imager Board must be disconnected from the Timing Board before power is applied. If the Imager Board is connected to the Timing Board during the reprogramming of the Altera PLD, damage to the Imager Board will occur.

Purchasers of a an Evaluation Board Kit may, at their discretion, make changes to the Timing Generator Board firmware. ON Semiconductor can only support firmware developed by, and supplied by, ON Semiconductor. Changes to the firmware are at the risk of the customer.

**Ordering Information**

Please address all inquiries and purchase orders to:

Truesense Imaging, Inc.  
 1964 Lake Avenue  
 Rochester, New York 14615  
 Phone: (585) 784-5500  
 E-mail: info@truesenseimaging.com

ON Semiconductor reserves the right to change any information contained herein without notice. All information furnished by ON Semiconductor is believed to be accurate.

**onsemi**, **Onsemi**, and other names, marks, and brands are registered and/or common law trademarks of Semiconductor Components Industries, LLC dba "**onsemi**" or its affiliates and/or subsidiaries in the United States and/or other countries. **onsemi** owns the rights to a number of patents, trademarks, copyrights, trade secrets, and other intellectual property. A listing of **onsemi**'s product/patent coverage may be accessed at [www.onsemi.com/site/pdf/Patent-Marking.pdf](http://www.onsemi.com/site/pdf/Patent-Marking.pdf). **onsemi** is an Equal Opportunity/Affirmative Action Employer. This literature is subject to all applicable copyright laws and is not for resale in any manner.

The evaluation board/kit (research and development board/kit) (hereinafter the "board") is not a finished product and is not available for sale to consumers. The board is only intended for research, development, demonstration and evaluation purposes and will only be used in laboratory/development areas by persons with an engineering/technical training and familiar with the risks associated with handling electrical/mechanical components, systems and subsystems. This person assumes full responsibility/liability for proper and safe handling. Any other use, resale or redistribution for any other purpose is strictly prohibited.

**THE BOARD IS PROVIDED BY ONSEMI TO YOU "AS IS" AND WITHOUT ANY REPRESENTATIONS OR WARRANTIES WHATSOEVER. WITHOUT LIMITING THE FOREGOING, ONSEMI (AND ITS LICENSORS/SUPPLIERS) HEREBY DISCLAIMS ANY AND ALL REPRESENTATIONS AND WARRANTIES IN RELATION TO THE BOARD, ANY MODIFICATIONS, OR THIS AGREEMENT, WHETHER EXPRESS, IMPLIED, STATUTORY OR OTHERWISE, INCLUDING WITHOUT LIMITATION ANY AND ALL REPRESENTATIONS AND WARRANTIES OF MERCHANTABILITY, FITNESS FOR A PARTICULAR PURPOSE, TITLE, NON-INFRINGEMENT, AND THOSE ARISING FROM A COURSE OF DEALING, TRADE USAGE, TRADE CUSTOM OR TRADE PRACTICE.**

**onsemi** reserves the right to make changes without further notice to any board.

You are responsible for determining whether the board will be suitable for your intended use or application or will achieve your intended results. Prior to using or distributing any systems that have been evaluated, designed or tested using the board, you agree to test and validate your design to confirm the functionality for your application. Any technical, applications or design information or advice, quality characterization, reliability data or other services provided by **onsemi** shall not constitute any representation or warranty by **onsemi**, and no additional obligations or liabilities shall arise from **onsemi** having provided such information or services.

**onsemi** products including the boards are not designed, intended, or authorized for use in life support systems, or any FDA Class 3 medical devices or medical devices with a similar or equivalent classification in a foreign jurisdiction, or any devices intended for implantation in the human body. You agree to indemnify, defend and hold harmless **onsemi**, its directors, officers, employees, representatives, agents, subsidiaries, affiliates, distributors, and assigns, against any and all liabilities, losses, costs, damages, judgments, and expenses, arising out of any claim, demand, investigation, lawsuit, regulatory action or cause of action arising out of or associated with any unauthorized use, even if such claim alleges that **onsemi** was negligent regarding the design or manufacture of any products and/or the board.

This evaluation board/kit does not fall within the scope of the European Union directives regarding electromagnetic compatibility, restricted substances (RoHS), recycling (WEEE), FCC, CE or UL, and may not meet the technical requirements of these or other related directives.

FCC WARNING – This evaluation board/kit is intended for use for engineering development, demonstration, or evaluation purposes only and is not considered by **onsemi** to be a finished end product fit for general consumer use. It may generate, use, or radiate radio frequency energy and has not been tested for compliance with the limits of computing devices pursuant to part 15 of FCC rules, which are designed to provide reasonable protection against radio frequency interference. Operation of this equipment may cause interference with radio communications, in which case the user shall be responsible, at its expense, to take whatever measures may be required to correct this interference.

**onsemi** does not convey any license under its patent rights nor the rights of others.

LIMITATIONS OF LIABILITY: **onsemi** shall not be liable for any special, consequential, incidental, indirect or punitive damages, including, but not limited to the costs of requalification, delay, loss of profits or goodwill, arising out of or in connection with the board, even if **onsemi** is advised of the possibility of such damages. In no event shall **onsemi**'s aggregate liability from any obligation arising out of or in connection with the board, under any theory of liability, exceed the purchase price paid for the board, if any.

The board is provided to you subject to the license and other terms per **onsemi**'s standard terms and conditions of sale. For more information and documentation, please visit [www.onsemi.com](http://www.onsemi.com).

## PUBLICATION ORDERING INFORMATION

### LITERATURE FULFILLMENT:

Email Requests to: [orderlit@onsemi.com](mailto:orderlit@onsemi.com)

**onsemi Website:** [www.onsemi.com](http://www.onsemi.com)

### TECHNICAL SUPPORT

**North American Technical Support:**

Voice Mail: 1 800-282-9855 Toll Free USA/Canada

Phone: 011 421 33 790 2910

**Europe, Middle East and Africa Technical Support:**

Phone: 00421 33 790 2910

For additional information, please contact your local Sales Representative