

NCP1090GEVB, NCP1094GEVB



ON Semiconductor®

www.onsemi.com

Power-over-Ethernet PD Interface Evaluation Board User's Manual

EVAL BOARD USER'S MANUAL

Introduction

The NCP1090GEVB and NCP1094GEVB evaluation boards are designed to showcase the features of the NCP109x series of Power-over-Ethernet interfaces. The boards are designed as splitter interfaces, taking a PoE-enabled port as input and offering the power to a separate connector, while passing through the data to another Ethernet port. The schematics, gerber files and BOM of these boards are available through our website (www.onsemi.com)

Basic Circuit Description

The evaluation boards consist of different sections that will be described in detail in the next paragraphs. First, we will discuss the input section, including selection of the correct connectors, magnetics and the termination for a Power-over-Ethernet enabled connection. In the next section we will explain the operation of the NCP109x, the detection and classification process, and how to configure the NCP109x for the correct power class. Finally, we will explain how to use the UVLO support (for NCP1091 and NCP1093) or auxiliary support (for NCP1092 and NCP1094).

Table 1. ELECTRICAL CHARACTERISTICS

	NCP1090, NCP1091, NCP1092	NCP1093, NCP1094
Input Voltage, PoE	37 V – 57 V	
Input Current, PoE	500 mA	680 mA
Auxiliary Input Voltage	10.8 V – 57 V	
Auxiliary Input Current	0 – 5 A	

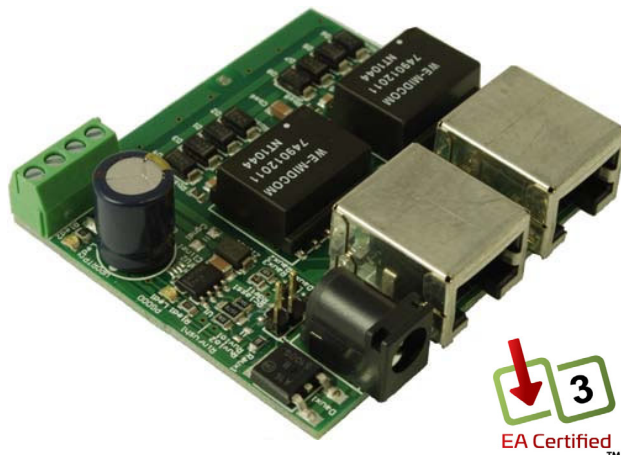

Figure 1. NCP1090GEVB Photo



Figure 2. NCP1094GEVB Photo

NCP1090GEVB, NCP1094GEVB

INPUT SECTION

Ethernet Connectors, Magnetics and Termination

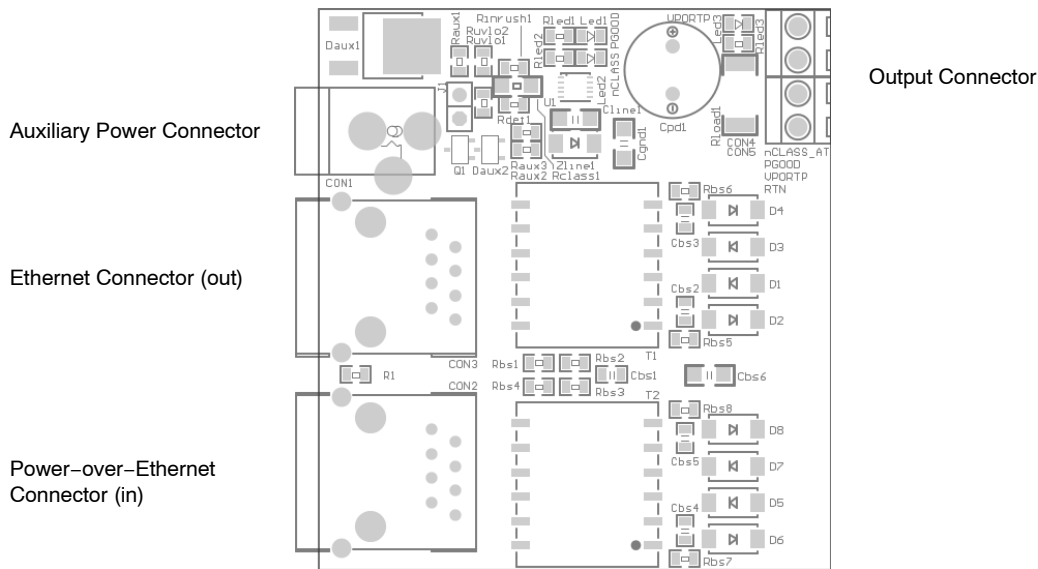

Figure 3. Connection Diagram

The NCP109x evaluation boards have 2 RJ45 connectors. One connector is used as the input connector and supports Power-over-Ethernet. The power from this connector is split off to the NCP109x while the Ethernet data is passed through to the other RJ45 connector. Please note that this second connector will not support Power-over-Ethernet. When the

output connector is connected to a proper Power-over-Ethernet PSE, the PD detection will fail without damaging the board, and no power will be applied. When power is applied across the pairs of this second connector without negotiation, the board will burn out the termination resistors.

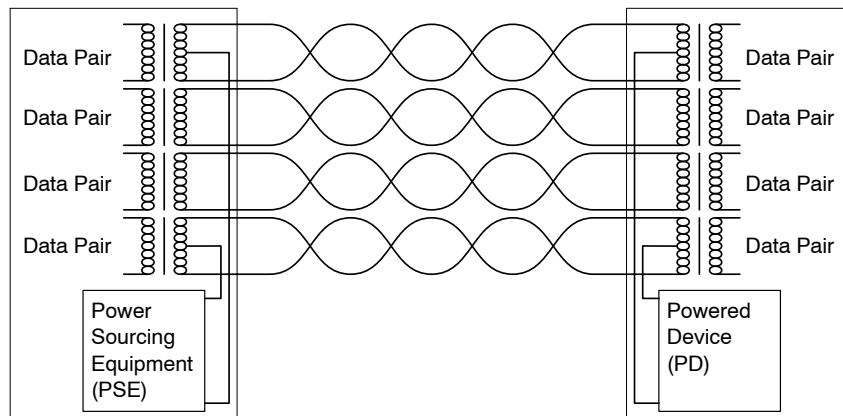

Figure 4. Ethernet Connection with Power-over-Ethernet

Ethernet connections are double isolated, which means the data passes through a signal transformer on both on the Power Supply Equipment (PSE) side as well as on the Powered Device (PD) side. In the case that the port must support Power-over-Ethernet, specific signal transformers must be selected. First, the signal transformers must have a central tap to access the common mode voltage of each pair, as these are the carriers for the PoE power. Second, care must be taken to select transformers that can support the dc common mode current required (up to 350 mA for the

IEEE802.3-af standard and 600 mA for the IEEE802.3-at standard) without high losses. It is recommended to choose magnetics that include common-mode chokes to reduce electromagnetic emissions. When board space is critical, it can be interesting to choose connectors with build-in magnetics ('MagJack'). These connectors also integrate the termination of the Ethernet line. Contact your magnetics manufacturer for more information on magnetics suitable for PoE.

NCP1090GEVB, NCP1094GEVB

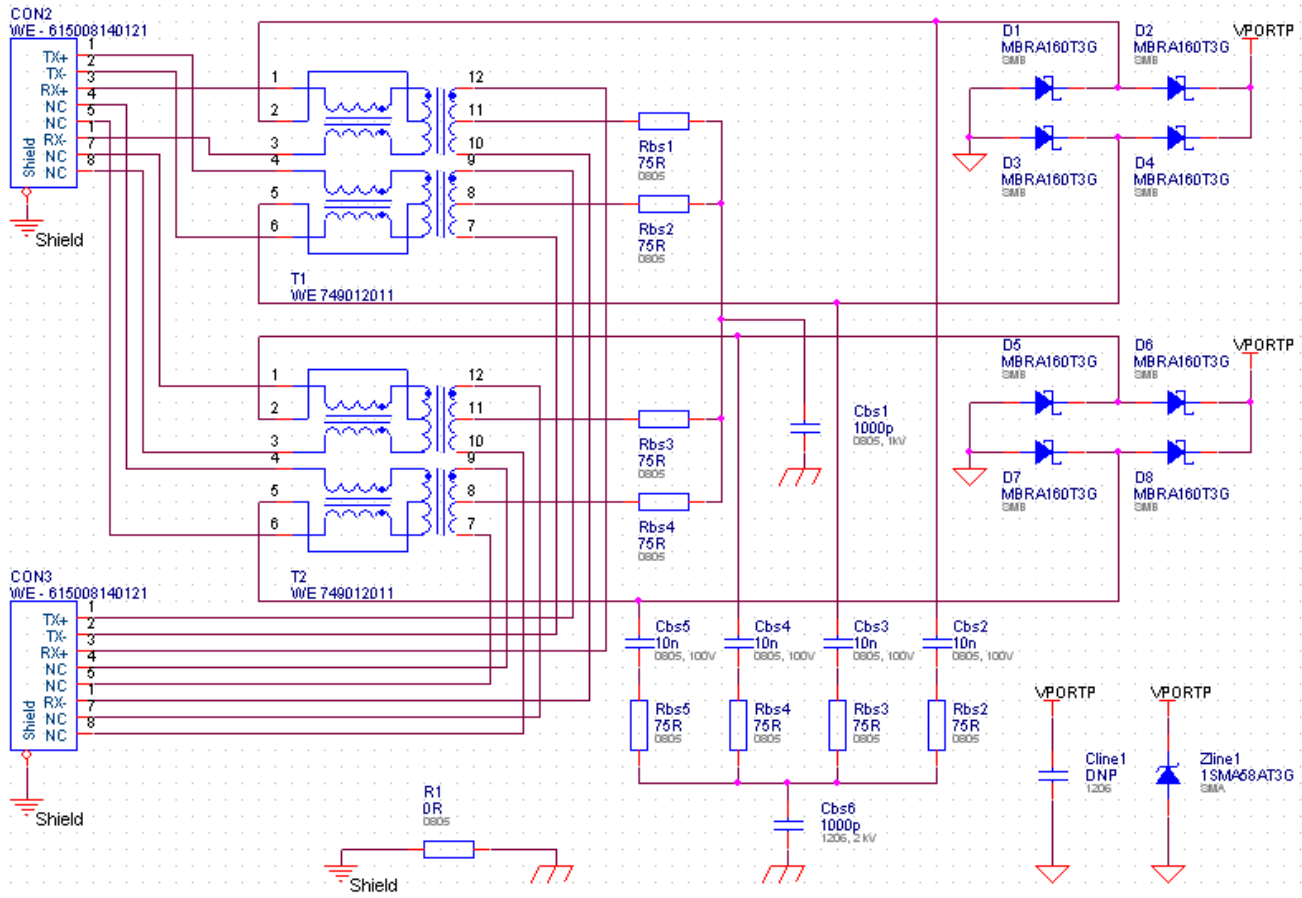

Figure 5. Input Section of the Evaluation Boards

Termination

Termination of an Ethernet port should be done on the connector side of the magnetics. The typical termination for Ethernet ports is called a ‘Bob Smith termination’ and is shown in Figure 6.

For ports that are Power-over-Ethernet, this termination network should be modified to block the DC common mode voltage between pairs from creating a large current through the termination resistors, which would blow up the termination resistors. This is done by inserting 10 nF blocking capacitors in series with the termination resistors. The modified termination network is shown in Figure 7.

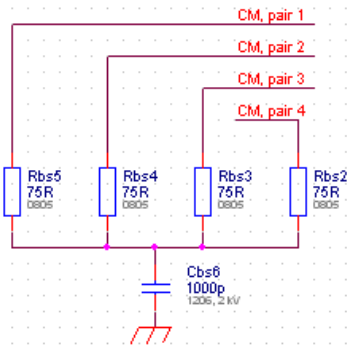

Figure 6. Bob-Smith Termination

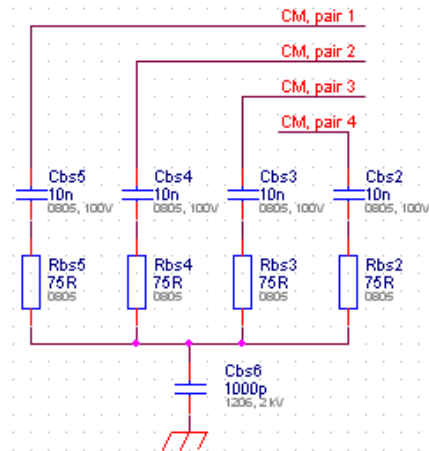

Figure 7. Modified Bob-Smith Termination

Rectification and Protection

Power applied to the Ethernet pairs has no defined polarity and thus needs to be rectified by diode bridges. The diode selection is important for the total efficiency of the system, as the forward voltage drop of the diode can be quite large. For this reason, discrete schottky diodes are a common choice for the rectification bridge. To comply with ESD protection guidelines, a TVS should be added to the rectified power lines. In the evaluation boards, the 1SMA58AT3G was selected for this part.

NCP109x OPERATION

Power-over-Ethernet Detection and Classification

To distinguish power-over-ethernet enabled ports from regular Ethernet ports, the Power Supply Equipment (PSE) will first check the detection signature of the Powered Device (PD), before negotiating and applying power. The detection signature is defined as the resistance between VPOR_{TP} and VPOR_{TN}, and should be larger than 19 kΩ and smaller than 26.5 kΩ. Typically, a value of 24.9 kΩ is used.

The PSE will measure this resistance by making at least two measurements of the current drawn by the PD while applying voltages between 2.8 and 10 V. From these measurements, the PSE will make a linear approximation from which it will extract the detection resistance.

This means that the total resistance seen at the input of the PD should be equal to 24.9 kΩ. During detection, the DET pin is connected to ground, so for the schematic of the evaluation board, this means that:

$$(R_{UVLO1} + R_{UVLO2}) // R_{det} = 24.9 \text{ k}\Omega$$

For the detection and classification to succeed, the total input capacitance of the PD should be limited to less than 150 nF. When the input capacitance is higher, the capacitor charge current will influence the detection resistance measurements, and the detection signature will be invalid. Under no circumstance is it allowed to connect the bulk input capacitor (generally in the order of magnitude of 1-10 μF) of the DC/DC convertor to VPOR_{TN}. The bulk input capacitor should always be located on the other side of the pass switch, and the negative lead should be connected to RTN. As such, the bulk input capacitor will remain disconnected during detection, and will not influence the detection signature.

Once the detection phase is passed, the NCP109x will disconnect the DET pin to save power that would otherwise be dissipated in the detection resistor.

When the PSE has detected a valid PD signature, the PSE will start the classification phase. During the classification phase, the PSE will determine the power class of the PD. This is determined by measuring the current drawn when a voltage pulse of typically 17.5 V is applied. Class 4 is only valid in 802.3at. In 802.3af, class 4 is defined as reserved and treated as class 0. So to make sure that the PD can distinguish between at-type PSEs (applying 25.5 W for class 4) and af-type PSEs (applying 13 W for class 4), the classification pulse is repeated by the at-type PSE when the PD is programmed for class 4. This difference is made visible to external components through the nClassAT pin.

The power class can be programmed by setting the classification resistor to the correct value. Programming resistors should be placed as close to the IC as possible to minimize noise. The different power classes and their corresponding classification resistors are listed in Table 2.

Table 2. PD POWER CLASSIFICATION

Power Class	Average Input Power of the PD	Classification Resistor
0	13 W	4.42 kΩ
1	3.84 W	953 Ω
2	6.49 W	549 Ω
3	13 W	357 Ω
4*	25.5 W	255 Ω

*Only for NCP1093, NCP1094

After the PSE has detected a valid power class for the PD, it will apply the full power to the PD.

A typical classification sequence for a class 4 PD is shown in Figure 8.

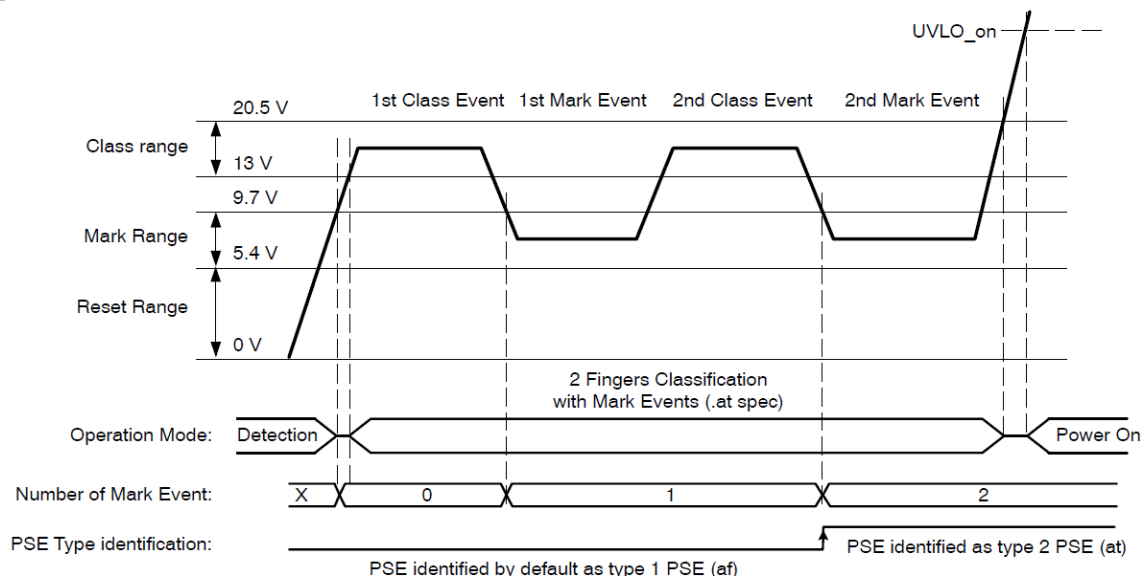

Figure 8. PD Classification for Class 4

NCP1090GEVB, NCP1094GEVB

Inrush and Operational Current Limitation

When the PSE applies power to the PD after the detection and classification phases, the pass switch will initially limit the current passing through it. In this way large currents caused by the DC/DC convertor input capacitor charging are prevented.

When the voltage over the pass switch drops below the limit value, this indicates that the bulk capacitor is charged.

The pass switch is then turned completely on, and the IC switches to an operational current limit. Both limits are programmed with the same programming resistor, which is connected to ILIM. Programming resistors should be placed as close to the IC as possible to minimize noise. Typical values for this programming resistor are shown in Table 3.

Table 3. PD INPUT CURRENT LIMITS

Average Input Power of the PD	Recommended ILIM Resistor	Inrush Current Limit	Operational Current Limit
13 W	178 kΩ	120 mA	500 mA
25.5 W	169 kΩ	120 mA	680 mA

PGOOD Indication

The NCP109x provide a PGOOD signal to indicate when the power is available for the DC/DC convertor. This is an open-drain output that is active when the input capacitor has not completely charged yet. The PGOOD pin is released (to an external pull-up) when the voltage between RTN and VPORTN drops below 1 V (typ.).

The intended use for this signal is to connect the PGOOD signal to the enable pin of your DC/DC controller, to ensure that the DC/DC controller does not start operation before the input capacitor is fully charged.

On the evaluation board the PGOOD pin is connected to a LED. Under normal operation, this LED should only turn on (briefly) during startup and shutdown.

UVLO Support

All NCP109x ICs have internal UVLO capability, and will disconnect the pass switch when the VPORTP voltage becomes too low. The threshold for this is set by an internal resistor divider to $V_{UVLO,on} = 37\text{ V}$ (typ) and $V_{UVLO,off} = 31\text{ V}$ (typ).

In addition, the NCP1091 and NCP1093 allow externally programming the threshold to a different value. If you want to continue using the default UVLO threshold with the NCP1091 or NCP1093, connect the UVLO pin to VPORTN.

To enable under-voltage lockout with a different threshold, you must populate the resistor divider created by Ruvlo1 and Ruvlo2. This can only be done on the NCP1091 or NCP1093.

The values for these components can be calculated as follows:

$$V_{uvlo,on} = 1.2\text{ V} \frac{R_{uvlo1} + R_{uvlo2}}{R_{uvlo2}}$$

Take also into account that the UVLO resistors will influence the detection resistance.

Auxiliary Support

An auxiliary supply can easily be implemented with a diode (Daux1). This auxiliary supply is often of a relatively low voltage (e.g. 24 V). However, this implementation can result in variable behavior, depending on which power

source was connected first. For example, when the auxiliary is already connected when the Ethernet cable is plugged in, the auxiliary voltage will interfere with the PoE detection, and this will result in a dominant auxiliary supply. However, if the Ethernet cable is connected first, the PoE detection will be successful, and power will be drawn from the PoE interface, even if an auxiliary supply is later connected.

It is often desirable for the device to always use the auxiliary supply, even when PoE is available. In that case, the PoE must be disabled when the auxiliary is active. This feature is available in the NCP1092 and NCP1094.

Auxiliary support will disconnect the PoE supply when an auxiliary supply is connected by disconnecting the internal pass switch. When not used, the AUX pin of the IC should be connected to VPORTN. To configure the auxiliary support dimension the resistor divider connected to the AUX pin so that the AUX pin voltage is higher than 3.1 V (typ.) during desired operation. The AUX pin has an internal pull-down resistor of 100 kΩ. However, such large resistance is not desired since a small leakage current can make the AUX voltage rise very quickly. It is advised to add an external pull-down resistor of 7.5 kΩ. From this we can dimension Raux1 as follows:

$$R_{aux1} = \left(\frac{V_{aux,on}}{3.1\text{ V}} - 1 \right) 7.5\text{ k}\Omega$$

When the voltage on the AUX pin rises above 3.1 V, the NCP109x will disable the PoE detection circuit and disconnect the pass switch, as well as release PGOOD.

To connect the auxiliary support (and have priority of the auxiliary supply) on the evaluation boards, you must connect the jumper J1. This is only possible if your evaluation board has an NCP1092 or NCP1094.

To get an efficient system, it is desirable to have the forward voltage drop over the auxiliary diode Daux1 as low as possible, especially since the auxiliary power supply is often of lower voltage and therefore has less headroom for voltage drop. This requires a schottky diode. However, schottky diodes at higher voltages often have a large reverse leakage current, up to as much as 10mA. If this current were

NCP1090GEVB, NCP1094GEVB

to flow through the auxiliary resistor divider, the AUX pin voltage would rise above the threshold, and turn off the PoE, even when no auxiliary supply is available. For this reason,

we put a PNP transistor (Q1) in series, which will disable this current path. The resulting schematic is shown in Figure 9.

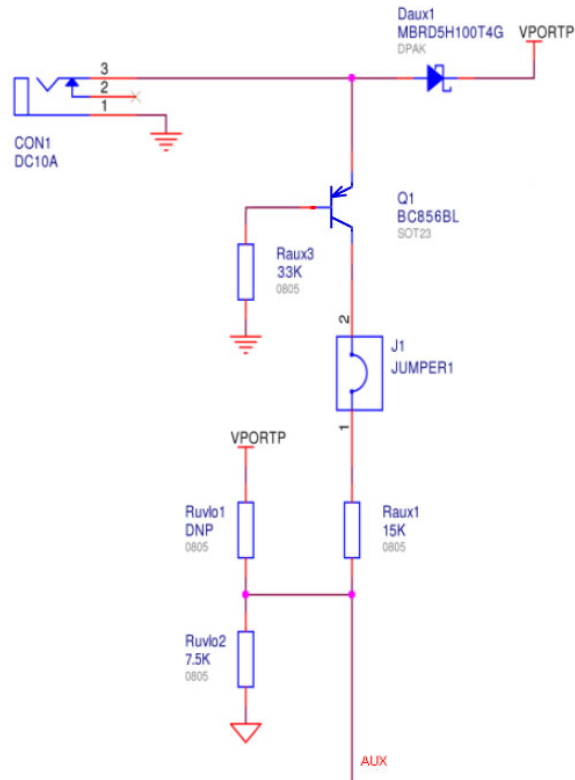

Figure 9. Auxiliary Supply Circuit

nClass_AT

The NCP1093 and NCP1094 are capable of classifying as class 4 as per the 802.3at standard, delivering up to 25.5 W.

If the PD is connected to a PSE complying with the 802.3af standard, the PSE will apply power after one classification event, but this power will be limited to 13 W.

To signal if the PSE went through the 2 event classification, and the full 25.5W is indeed available, the NCP1093 and NCP1094 offer the nClass_AT signal. This pin has an open drain output that is pulled low when two classification events have occurred.

onsemi, **Onsemi**, and other names, marks, and brands are registered and/or common law trademarks of Semiconductor Components Industries, LLC dba "**onsemi**" or its affiliates and/or subsidiaries in the United States and/or other countries. **onsemi** owns the rights to a number of patents, trademarks, copyrights, trade secrets, and other intellectual property. A listing of **onsemi**'s product/patent coverage may be accessed at www.onsemi.com/site/pdf/Patent-Marking.pdf. **onsemi** is an Equal Opportunity/Affirmative Action Employer. This literature is subject to all applicable copyright laws and is not for resale in any manner.

The evaluation board/kit (research and development board/kit) (hereinafter the "board") is not a finished product and is not available for sale to consumers. The board is only intended for research, development, demonstration and evaluation purposes and will only be used in laboratory/development areas by persons with an engineering/technical training and familiar with the risks associated with handling electrical/mechanical components, systems and subsystems. This person assumes full responsibility/liability for proper and safe handling. Any other use, resale or redistribution for any other purpose is strictly prohibited.

THE BOARD IS PROVIDED BY ONSEMI TO YOU "AS IS" AND WITHOUT ANY REPRESENTATIONS OR WARRANTIES WHATSOEVER. WITHOUT LIMITING THE FOREGOING, ONSEMI (AND ITS LICENSORS/SUPPLIERS) HEREBY DISCLAIMS ANY AND ALL REPRESENTATIONS AND WARRANTIES IN RELATION TO THE BOARD, ANY MODIFICATIONS, OR THIS AGREEMENT, WHETHER EXPRESS, IMPLIED, STATUTORY OR OTHERWISE, INCLUDING WITHOUT LIMITATION ANY AND ALL REPRESENTATIONS AND WARRANTIES OF MERCHANTABILITY, FITNESS FOR A PARTICULAR PURPOSE, TITLE, NON-INFRINGEMENT, AND THOSE ARISING FROM A COURSE OF DEALING, TRADE USAGE, TRADE CUSTOM OR TRADE PRACTICE.

onsemi reserves the right to make changes without further notice to any board.

You are responsible for determining whether the board will be suitable for your intended use or application or will achieve your intended results. Prior to using or distributing any systems that have been evaluated, designed or tested using the board, you agree to test and validate your design to confirm the functionality for your application. Any technical, applications or design information or advice, quality characterization, reliability data or other services provided by **onsemi** shall not constitute any representation or warranty by **onsemi**, and no additional obligations or liabilities shall arise from **onsemi** having provided such information or services.

onsemi products including the boards are not designed, intended, or authorized for use in life support systems, or any FDA Class 3 medical devices or medical devices with a similar or equivalent classification in a foreign jurisdiction, or any devices intended for implantation in the human body. You agree to indemnify, defend and hold harmless **onsemi**, its directors, officers, employees, representatives, agents, subsidiaries, affiliates, distributors, and assigns, against any and all liabilities, losses, costs, damages, judgments, and expenses, arising out of any claim, demand, investigation, lawsuit, regulatory action or cause of action arising out of or associated with any unauthorized use, even if such claim alleges that **onsemi** was negligent regarding the design or manufacture of any products and/or the board.

This evaluation board/kit does not fall within the scope of the European Union directives regarding electromagnetic compatibility, restricted substances (RoHS), recycling (WEEE), FCC, CE or UL, and may not meet the technical requirements of these or other related directives.

FCC WARNING – This evaluation board/kit is intended for use for engineering development, demonstration, or evaluation purposes only and is not considered by **onsemi** to be a finished end product fit for general consumer use. It may generate, use, or radiate radio frequency energy and has not been tested for compliance with the limits of computing devices pursuant to part 15 of FCC rules, which are designed to provide reasonable protection against radio frequency interference. Operation of this equipment may cause interference with radio communications, in which case the user shall be responsible, at its expense, to take whatever measures may be required to correct this interference.

onsemi does not convey any license under its patent rights nor the rights of others.

LIMITATIONS OF LIABILITY: **onsemi** shall not be liable for any special, consequential, incidental, indirect or punitive damages, including, but not limited to the costs of requalification, delay, loss of profits or goodwill, arising out of or in connection with the board, even if **onsemi** is advised of the possibility of such damages. In no event shall **onsemi**'s aggregate liability from any obligation arising out of or in connection with the board, under any theory of liability, exceed the purchase price paid for the board, if any.

The board is provided to you subject to the license and other terms per **onsemi**'s standard terms and conditions of sale. For more information and documentation, please visit www.onsemi.com.

PUBLICATION ORDERING INFORMATION

LITERATURE FULFILLMENT:

Email Requests to: orderlit@onsemi.com

onsemi Website: www.onsemi.com

TECHNICAL SUPPORT

North American Technical Support:

Voice Mail: 1 800-282-9855 Toll Free USA/Canada

Phone: 011 421 33 790 2910

Europe, Middle East and Africa Technical Support:

Phone: 00421 33 790 2910

For additional information, please contact your local Sales Representative