

# NCP1421LEDEVB

## NCP1421 High Current LED Driver Evaluation Board User's Manual



ON Semiconductor®

<http://onsemi.com>

### EVAL BOARD USER'S MANUAL

#### Description

The NCP1421 is a monolithic, micro-power, high-frequency, step-up switching converter IC designed for battery operated hand-held electronic products with up to 600 mA loading. It integrates a synchronous rectifier (Sync-Rect) to improve efficiency and to eliminate the external Schottky Diode. The NCP1421's high switching frequency (up to 1.2 MHz) allows for a low profile, small sized inductor and output capacitor to be used. When the device is disabled, the internal conduction path from the battery to the load is fully blocked, which isolates the load from the battery. This True-Cutoff function reduces the shutdown current to typically only 50 nA. A Ring-Killer is also integrated to eliminate high-frequency ringing in discontinuous conduction mode. Finally, a Low-Battery Detector, Logic-Controlled Shutdown, Cycle-by Cycle Current Limiting and Thermal Shutdown provide value-added features for various battery operated applications. With all these functions on, the quiescent supply current is typically only 8.5  $\mu$ A. This device is available in the compact and low profile Micro8™ package.

The NCP1421LED evaluation board uses the NCP1421 to drive a high power, white LED. The circuit is configured to minimize power dissipation in the current sense resistor and the effects of lot-to-lot LED forward voltage (VF) variation on LED current.

#### Features

- Capable of driving White LEDs up to 600 mA
- High Switching Frequency, up to 1.2 MHz
- True-Cutoff Function Reduces Device Shutdown Current to Typically 50 nA

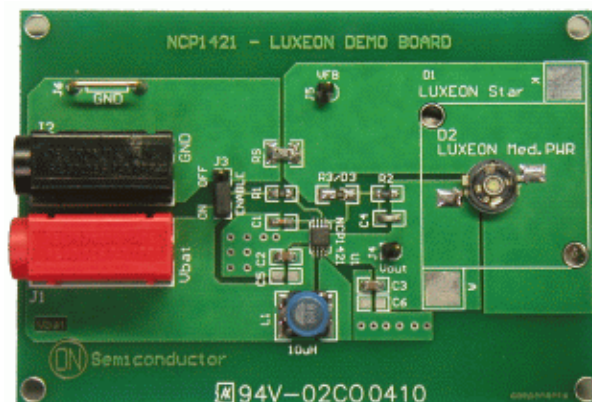

Figure 1. NCP1421LED Evaluation Board

#### Test Procedure

1. Set DC Power Supply to 3.6 Vdc and Current Limit to 2 A
2. Move Jumper on J3 to OFF Position
3. Connect DC Power Supply to J1 and J2 (Positive on J1 (Vbat), Negative on J2 (GND))
4. LED Should be Off
5. Remove Jumper Completely from J3
6. LED Should still be Off
7. Set Jumper on J3 to the ON Position
8. LED Should be On (CAUTION, DO NOT LOOK DIRECTLY AT THE LED. IT IS EXTREMELY BRIGHT)
9. Measure Voltage from J5 (VFB) to J6 (GND). It Should be between 500–700 mV

# NCP1421LEDEVB

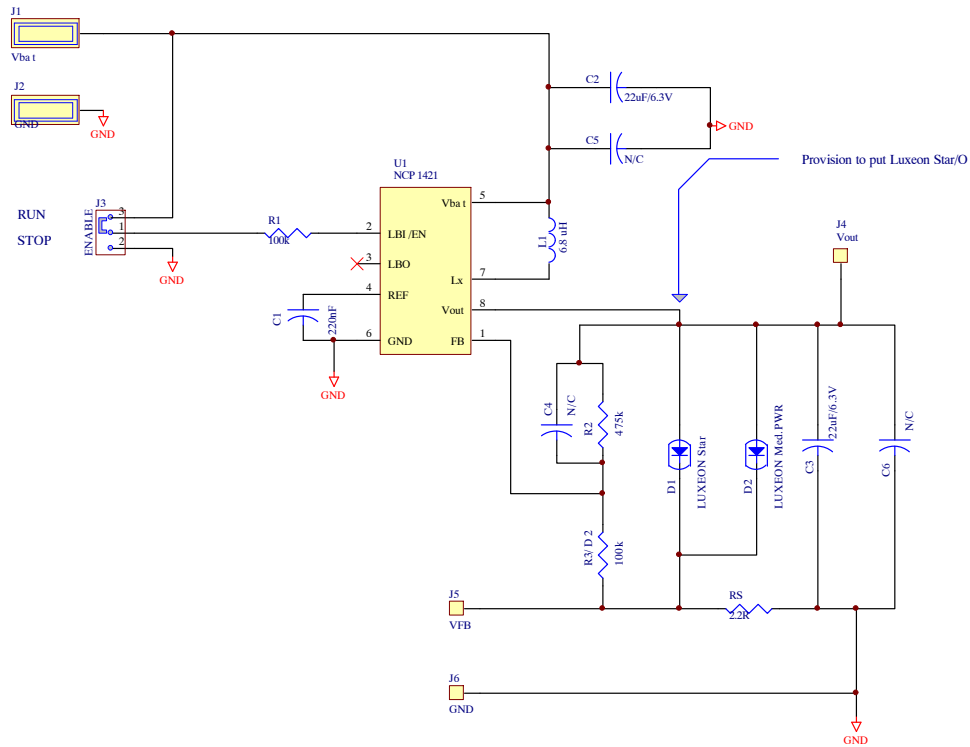

Figure 1. NCP1421LED Evaluation Board Schematic

Table 1. NCP1421LED EVALUATION BOARD BILL OF MATERIALS

Designator	Qty.	Description	Value	Tolerance	Footprint	Manufacturer	Manufacturer Part Number	Substitution Allowed	Lead Free
U1	1	Boost Converter	NA	NA	Micro8™	ON Semiconductor	NCP1421DMR2	No	No
D1/D2	1	High Power White LED	NA	NA	NA	Lumiled	LXHL-BW01/2	Yes	No
L1	1	SMD Inductor	6.8 μH, 1.6 A	20%	5.8 × 6.2 × 1.4 mm	TDK	VLP6214T-6R8M1R2	Yes	Yes
C1	1	Ceramic Chip Capacitor	220 nF	10%	0603	TDK	C1608X5R1C224MT	Yes	No
C2, C3	2	Ceramic Chip Capacitor	22 μF, 6.3 V	20%	0805	TDK	C2012X5R0J226M	Yes	No
C4	0	Ceramic Feedforward Cap	-	-	-	-	-	-	-
R1, R3	2	Chip Resistor	100 kΩ, 1/8 W	1%	0805	Yageo-America	9C08052A1003FKHFT	Yes	No
R2	1	Chip Resistor	475 kΩ, 1/8 W	1%	0805	Yageo-America	9C08052A4753FKHFT	Yes	No
RS	1	Chip Resistor	1.0 Ω, 1.0 W	1%	1218*	Vishay	CRCW12181R00FT	Yes	No
J1	1	4MM PCB Socket, Black	NA	NA	NA	Deltron Emcon	571-0100	Yes	No
J2	1	4MM PCB Socket, Red	NA	NA	NA	Deltron Emcon	571-0500	Yes	No
J3	1	Header Pins, 3 Positions	1" Pitch	NA	NA	Tyco Electronics/AMP	4-103239-0	Yes	No
J4, J5	2	Header Pins, 1 Position	1" Pitch	NA	NA	Tyco Electronics/AMP	4-103239-0	Yes	No
J3	1	Jumper, 2 Positions	1" Pitch	NA	NA	Sullins Electronics	SPC02SYAN	Yes	No
J6	1	Un-insulated Plug	NA	NA	10.16 × 9.0 mm	Harwin	D3082-05	Yes	No

\*2 1206, 2 Ω resistors were placed in parallel on this board

Micro8 is a trademark of International Rectifier.

**onsemi**, **Onsemi**, and other names, marks, and brands are registered and/or common law trademarks of Semiconductor Components Industries, LLC dba "**onsemi**" or its affiliates and/or subsidiaries in the United States and/or other countries. **onsemi** owns the rights to a number of patents, trademarks, copyrights, trade secrets, and other intellectual property. A listing of **onsemi**'s product/patent coverage may be accessed at [www.onsemi.com/site/pdf/Patent-Marking.pdf](http://www.onsemi.com/site/pdf/Patent-Marking.pdf). **onsemi** is an Equal Opportunity/Affirmative Action Employer. This literature is subject to all applicable copyright laws and is not for resale in any manner.

The evaluation board/kit (research and development board/kit) (hereinafter the "board") is not a finished product and is not available for sale to consumers. The board is only intended for research, development, demonstration and evaluation purposes and will only be used in laboratory/development areas by persons with an engineering/technical training and familiar with the risks associated with handling electrical/mechanical components, systems and subsystems. This person assumes full responsibility/liability for proper and safe handling. Any other use, resale or redistribution for any other purpose is strictly prohibited.

**THE BOARD IS PROVIDED BY ONSEMI TO YOU "AS IS" AND WITHOUT ANY REPRESENTATIONS OR WARRANTIES WHATSOEVER. WITHOUT LIMITING THE FOREGOING, ONSEMI (AND ITS LICENSORS/SUPPLIERS) HEREBY DISCLAIMS ANY AND ALL REPRESENTATIONS AND WARRANTIES IN RELATION TO THE BOARD, ANY MODIFICATIONS, OR THIS AGREEMENT, WHETHER EXPRESS, IMPLIED, STATUTORY OR OTHERWISE, INCLUDING WITHOUT LIMITATION ANY AND ALL REPRESENTATIONS AND WARRANTIES OF MERCHANTABILITY, FITNESS FOR A PARTICULAR PURPOSE, TITLE, NON-INFRINGEMENT, AND THOSE ARISING FROM A COURSE OF DEALING, TRADE USAGE, TRADE CUSTOM OR TRADE PRACTICE.**

**onsemi** reserves the right to make changes without further notice to any board.

You are responsible for determining whether the board will be suitable for your intended use or application or will achieve your intended results. Prior to using or distributing any systems that have been evaluated, designed or tested using the board, you agree to test and validate your design to confirm the functionality for your application. Any technical, applications or design information or advice, quality characterization, reliability data or other services provided by **onsemi** shall not constitute any representation or warranty by **onsemi**, and no additional obligations or liabilities shall arise from **onsemi** having provided such information or services.

**onsemi** products including the boards are not designed, intended, or authorized for use in life support systems, or any FDA Class 3 medical devices or medical devices with a similar or equivalent classification in a foreign jurisdiction, or any devices intended for implantation in the human body. You agree to indemnify, defend and hold harmless **onsemi**, its directors, officers, employees, representatives, agents, subsidiaries, affiliates, distributors, and assigns, against any and all liabilities, losses, costs, damages, judgments, and expenses, arising out of any claim, demand, investigation, lawsuit, regulatory action or cause of action arising out of or associated with any unauthorized use, even if such claim alleges that **onsemi** was negligent regarding the design or manufacture of any products and/or the board.

This evaluation board/kit does not fall within the scope of the European Union directives regarding electromagnetic compatibility, restricted substances (RoHS), recycling (WEEE), FCC, CE or UL, and may not meet the technical requirements of these or other related directives.

FCC WARNING – This evaluation board/kit is intended for use for engineering development, demonstration, or evaluation purposes only and is not considered by **onsemi** to be a finished end product fit for general consumer use. It may generate, use, or radiate radio frequency energy and has not been tested for compliance with the limits of computing devices pursuant to part 15 of FCC rules, which are designed to provide reasonable protection against radio frequency interference. Operation of this equipment may cause interference with radio communications, in which case the user shall be responsible, at its expense, to take whatever measures may be required to correct this interference.

**onsemi** does not convey any license under its patent rights nor the rights of others.

LIMITATIONS OF LIABILITY: **onsemi** shall not be liable for any special, consequential, incidental, indirect or punitive damages, including, but not limited to the costs of requalification, delay, loss of profits or goodwill, arising out of or in connection with the board, even if **onsemi** is advised of the possibility of such damages. In no event shall **onsemi**'s aggregate liability from any obligation arising out of or in connection with the board, under any theory of liability, exceed the purchase price paid for the board, if any.

The board is provided to you subject to the license and other terms per **onsemi**'s standard terms and conditions of sale. For more information and documentation, please visit [www.onsemi.com](http://www.onsemi.com).

## PUBLICATION ORDERING INFORMATION

### LITERATURE FULFILLMENT:

Email Requests to: [orderlit@onsemi.com](mailto:orderlit@onsemi.com)

**onsemi Website:** [www.onsemi.com](http://www.onsemi.com)

### TECHNICAL SUPPORT

**North American Technical Support:**

Voice Mail: 1 800-282-9855 Toll Free USA/Canada

Phone: 011 421 33 790 2910

**Europe, Middle East and Africa Technical Support:**

Phone: 00421 33 790 2910

For additional information, please contact your local Sales Representative