

ON Semiconductor

Is Now

onsemi™

To learn more about onsemi™, please visit our website at
www.onsemi.com

onsemi and **onsemi** and other names, marks, and brands are registered and/or common law trademarks of Semiconductor Components Industries, LLC dba "**onsemi**" or its affiliates and/or subsidiaries in the United States and/or other countries. **onsemi** owns the rights to a number of patents, trademarks, copyrights, trade secrets, and other intellectual property. A listing of **onsemi** product/patent coverage may be accessed at www.onsemi.com/site/pdf/Patent-Marking.pdf. **onsemi** reserves the right to make changes at any time to any products or information herein, without notice. The information herein is provided "as-is" and **onsemi** makes no warranty, representation or guarantee regarding the accuracy of the information, product features, availability, functionality, or suitability of its products for any particular purpose, nor does **onsemi** assume any liability arising out of the application or use of any product or circuit, and specifically disclaims any and all liability, including without limitation special, consequential or incidental damages. Buyer is responsible for its products and applications using **onsemi** products, including compliance with all laws, regulations and safety requirements or standards, regardless of any support or applications information provided by **onsemi**. "Typical" parameters which may be provided in **onsemi** data sheets and/or specifications can and do vary in different applications and actual performance may vary over time. All operating parameters, including "Typicals" must be validated for each customer application by customer's technical experts. **onsemi** does not convey any license under any of its intellectual property rights nor the rights of others. **onsemi** products are not designed, intended, or authorized for use as a critical component in life support systems or any FDA Class 3 medical devices or medical devices with a same or similar classification in a foreign jurisdiction or any devices intended for implantation in the human body. Should Buyer purchase or use **onsemi** products for any such unintended or unauthorized application, Buyer shall indemnify and hold **onsemi** and its officers, employees, subsidiaries, affiliates, and distributors harmless against all claims, costs, damages, and expenses, and reasonable attorney fees arising out of, directly or indirectly, any claim of personal injury or death associated with such unintended or unauthorized use, even if such claim alleges that **onsemi** was negligent regarding the design or manufacture of the part. **onsemi** is an Equal Opportunity/Affirmative Action Employer. This literature is subject to all applicable copyright laws and is not for resale in any manner. Other names and brands may be claimed as the property of others.



Automotive Mirror Control Design

ON Semiconductor®

<http://onsemi.com>

DESIGN NOTE

Circuit Description

The design note features two NCV7703 devices and a 250 mA capable low-drop-out regulator for side-view mirror application. The microcontroller unit (MCU) communicates with the NCV7703 via the serial peripheral interface (SPI) for driver operation and diagnostics. The SPI ports of the NCV7703 devices are configured in parallel configuration. Thus each of the integrated drivers has its own dedicated chip-select-bar (CSB) input signal from the microcontroller while the remaining SPI signals (SI, SCLK, SO) are shared. In a single SPI frame the MCU can only communicate with one NCV7703 device at a time with this configuration.

Two DC motors control the horizontal and the vertical movement of a side-view mirror. These motors are configured to the NCV7703 in a cascaded configuration, therefore, only one motor can be active at a given time.

Furthermore, the design schematic includes reverse battery protection and ESD suppression circuitry. Recommendations for DC bypass capacitors and current limiting resistors are also offered as a design aid.

Software Considerations

When programming the microcontroller for NCV7703 operation, the flow chart provided in Figure 2 can be used as a design reference. The chart illustrates how the MCU is kept in sleep mode when the reset is triggered by the LDO or the LDO is forced into a reset state due to a watchdog fault.

The flowchart shows that only one NCV7703 device is enabled at a given time; and the protection bits, over current detection shutdown, and the over voltage lockout controls are set to “1”. Furthermore, motor activation for specific axial movement and the non overlap delay is specified.

Key Features

- Right and Left Side-View Mirror Application
- Motor Control via SPI
- Under-Load Detection
- Over-Current Protection
- Reverse Battery Protection
- ESD Suppression

Table 1. DEVICE DETAILS

Device	Application	Load Dump	Channel Count	RDSon	Miscellaneous
NCV7703, NCV8518	Mirror Control	40 V	3	0.8 Ω (Typ)	Individual Driver Control

Table 2. OTHER SPECIFICATIONS

NCV7703 Output Current	0.5 A	Max
NCV7703 SPI Frequency	5 MHz	Max
NCV7703 Frame Length	16	Bits
Device Enable	Yes, NCV7703 & NCV8518	
Under Load Detection	Yes, NCV7703	
3.3 V/5 V System Compatible	Yes, NCV7703	
Over Voltage and Under Voltage Lockout	Yes, NCV7703	
Daisy Chain Compatible	Yes, NCV7703	
Watchdog	Yes, NCV8518	

SCHEMATIC

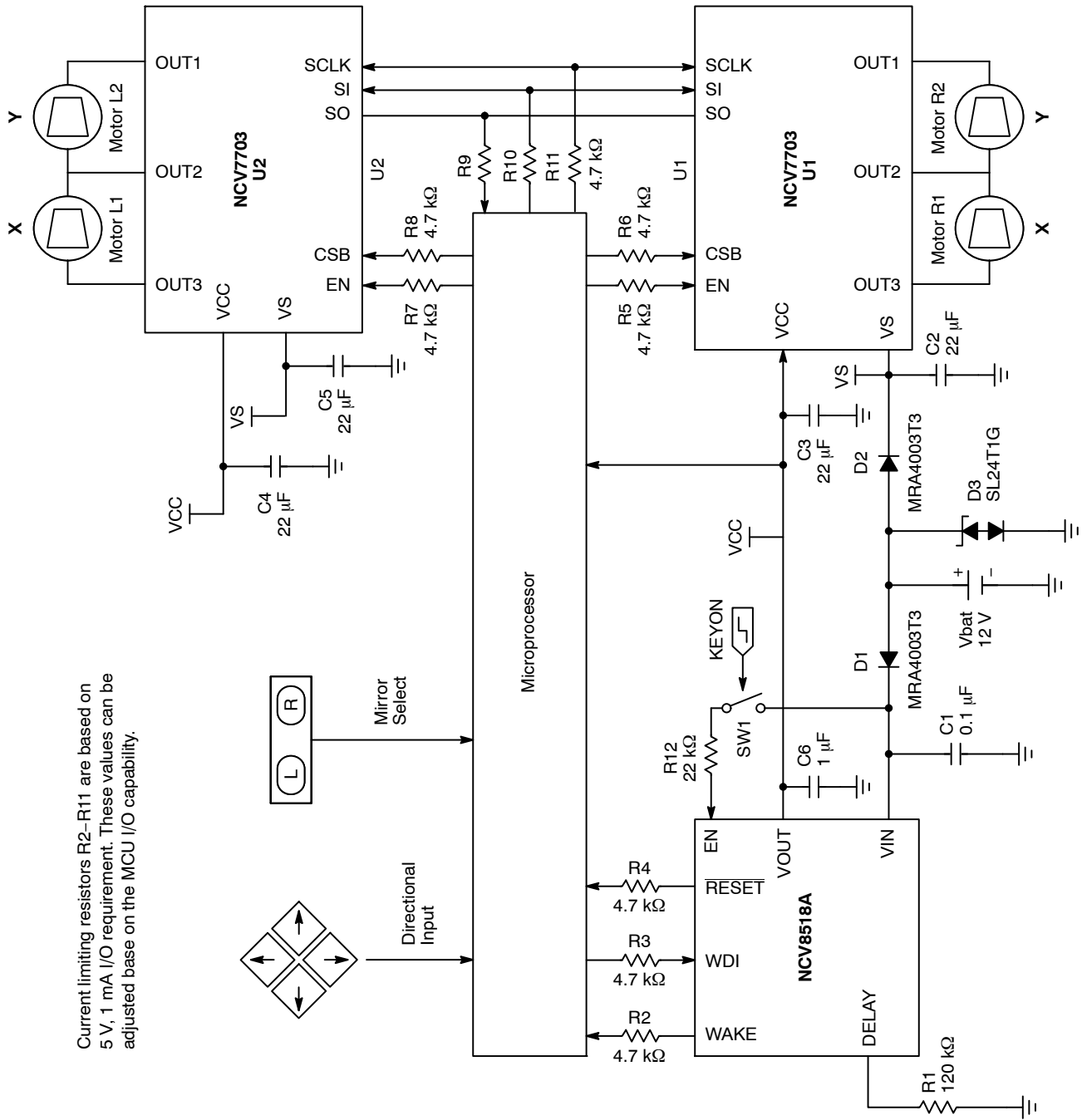

Current limiting resistors R2-R11 are based on 5 V, 1 mA I/O requirement. These values can be adjusted base on the MCU I/O capability.

Figure 1. Design Schematic

DN05026/D

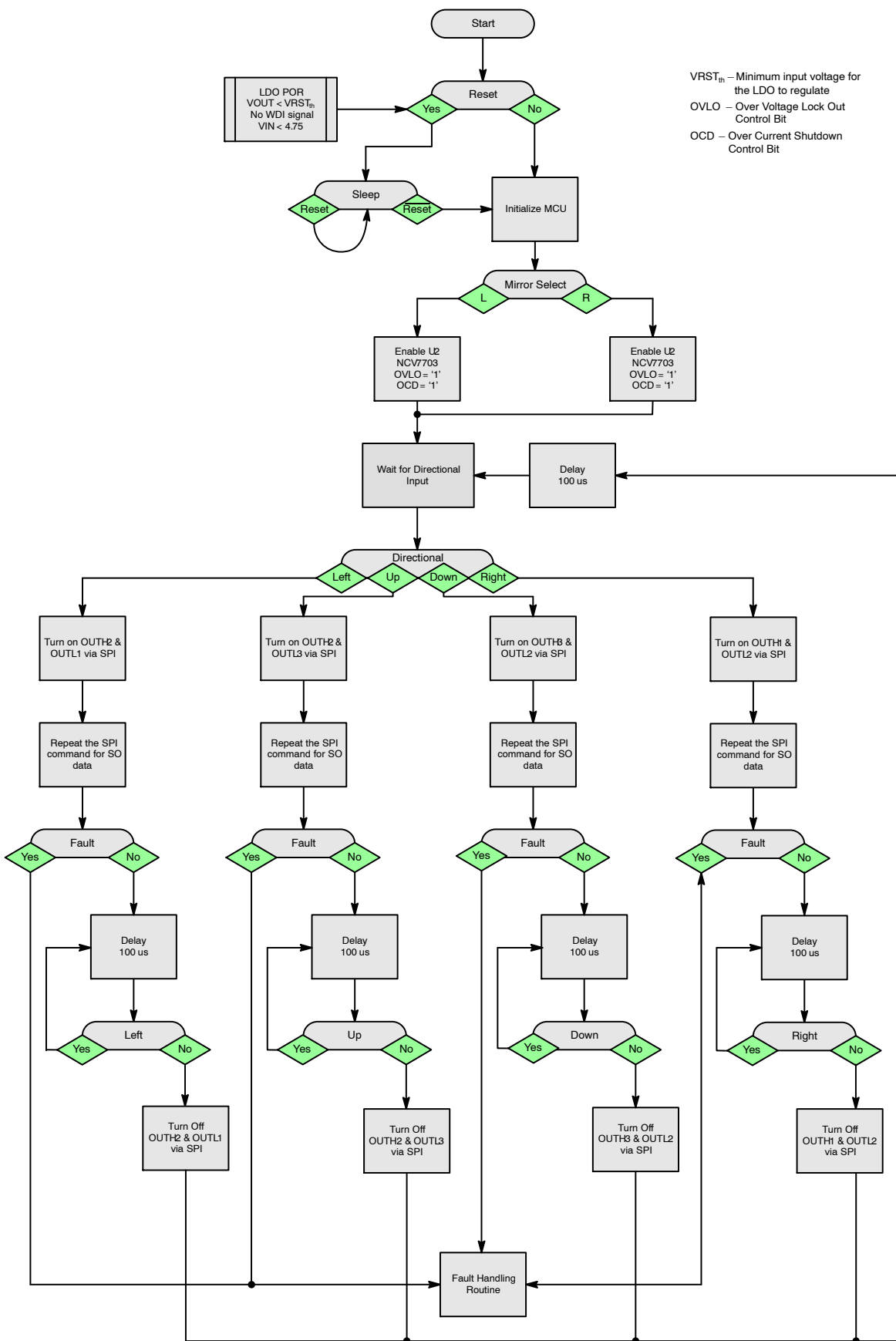

Figure 2. Software Flow Chart

ON Semiconductor and **ON** are registered trademarks of Semiconductor Components Industries, LLC (SCILLC). SCILLC owns the rights to a number of patents, trademarks, copyrights, trade secrets, and other intellectual property. A listing of SCILLC's product/patent coverage may be accessed at www.onsemi.com/site/pdf/Patent-Marking.pdf. SCILLC reserves the right to make changes without further notice to any products herein. SCILLC makes no warranty, representation or guarantee regarding the suitability of its products for any particular purpose, nor does SCILLC assume any liability arising out of the application or use of any product or circuit, and specifically disclaims any and all liability, including without limitation special, consequential or incidental damages. "Typical" parameters which may be provided in SCILLC data sheets and/or specifications can and do vary in different applications and actual performance may vary over time. All operating parameters, including "Typicals" must be validated for each customer application by customer's technical experts. SCILLC does not convey any license under its patent rights nor the rights of others. SCILLC products are not designed, intended, or authorized for use as components in systems intended for surgical implant into the body, or other applications intended to support or sustain life, or for any other application in which the failure of the SCILLC product could create a situation where personal injury or death may occur. Should Buyer purchase or use SCILLC products for any such unintended or unauthorized application, Buyer shall indemnify and hold SCILLC and its officers, employees, subsidiaries, affiliates, and distributors harmless against all claims, costs, damages, and expenses, and reasonable attorney fees arising out of, directly or indirectly, any claim of personal injury or death associated with such unintended or unauthorized use, even if such claim alleges that SCILLC was negligent regarding the design or manufacture of the part. SCILLC is an Equal Opportunity/Affirmative Action Employer. This literature is subject to all applicable copyright laws and is not for resale in any manner.

PUBLICATION ORDERING INFORMATION

LITERATURE FULFILLMENT:

Literature Distribution Center for ON Semiconductor
P.O. Box 5163, Denver, Colorado 80217 USA
Phone: 303-675-2175 or 800-344-3860 Toll Free USA/Canada
Fax: 303-675-2176 or 800-344-3867 Toll Free USA/Canada
Email: orderlit@onsemi.com

N. American Technical Support: 800-282-9855 Toll Free
USA/Canada
Europe, Middle East and Africa Technical Support:
Phone: 421 33 790 2910
Japan Customer Focus Center
Phone: 81-3-5817-1050

ON Semiconductor Website: www.onsemi.com

Order Literature: <http://www.onsemi.com/orderlit>

For additional information, please contact your local Sales Representative