

# ON Semiconductor

## Is Now

# onsemi™

To learn more about onsemi™, please visit our website at  
[www.onsemi.com](http://www.onsemi.com)

---

**onsemi** and **onsemi** and other names, marks, and brands are registered and/or common law trademarks of Semiconductor Components Industries, LLC dba "**onsemi**" or its affiliates and/or subsidiaries in the United States and/or other countries. **onsemi** owns the rights to a number of patents, trademarks, copyrights, trade secrets, and other intellectual property. A listing of **onsemi** product/patent coverage may be accessed at [www.onsemi.com/site/pdf/Patent-Marking.pdf](http://www.onsemi.com/site/pdf/Patent-Marking.pdf). **onsemi** reserves the right to make changes at any time to any products or information herein, without notice. The information herein is provided "as-is" and **onsemi** makes no warranty, representation or guarantee regarding the accuracy of the information, product features, availability, functionality, or suitability of its products for any particular purpose, nor does **onsemi** assume any liability arising out of the application or use of any product or circuit, and specifically disclaims any and all liability, including without limitation special, consequential or incidental damages. Buyer is responsible for its products and applications using **onsemi** products, including compliance with all laws, regulations and safety requirements or standards, regardless of any support or applications information provided by **onsemi**. "Typical" parameters which may be provided in **onsemi** data sheets and/or specifications can and do vary in different applications and actual performance may vary over time. All operating parameters, including "Typicals" must be validated for each customer application by customer's technical experts. **onsemi** does not convey any license under any of its intellectual property rights nor the rights of others. **onsemi** products are not designed, intended, or authorized for use as a critical component in life support systems or any FDA Class 3 medical devices or medical devices with a same or similar classification in a foreign jurisdiction or any devices intended for implantation in the human body. Should Buyer purchase or use **onsemi** products for any such unintended or unauthorized application, Buyer shall indemnify and hold **onsemi** and its officers, employees, subsidiaries, affiliates, and distributors harmless against all claims, costs, damages, and expenses, and reasonable attorney fees arising out of, directly or indirectly, any claim of personal injury or death associated with such unintended or unauthorized use, even if such claim alleges that **onsemi** was negligent regarding the design or manufacture of the part. **onsemi** is an Equal Opportunity/Affirmative Action Employer. This literature is subject to all applicable copyright laws and is not for resale in any manner. Other names and brands may be claimed as the property of others.

## BELASIGNA® R262 Prototyping Module User's Guide



**ON Semiconductor®**

<http://onsemi.com>

### APPLICATION NOTE

The BelaSigna R262 prototyping module is a miniature, self-contained unit that can be integrated into a product or prototype to evaluate the performance of BelaSigna R262 “in-form-factor”.

#### Key Features

The module is shown in Figure 1 and features:

- A miniature size of only 22 mm by 6 mm
- The 30-ball WLCSP version of BelaSigna R262 (BR262W30A103E1G)

- Two MEMS microphones spaced 10 mm apart (Knowles part number SPU0410HR5H-PB)
- Through-hole test points for external connections
- Configured to boot directly to the ROM application using the internal clock
- I<sup>2</sup>C and GPIO signals available on test points
- An onboard I<sup>2</sup>C EEPROM for optional custom application

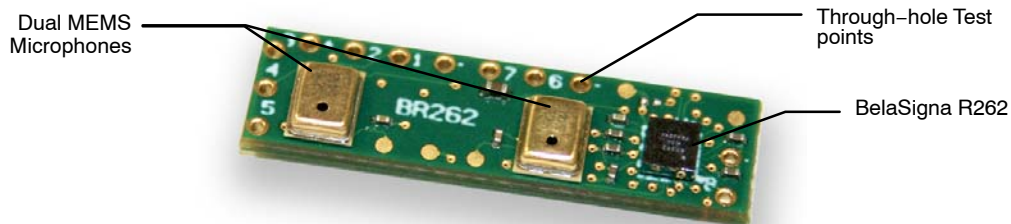

**Figure 1. BelaSigna R262 Prototyping Module**

#### Default Configuration

The prototyping module configures BelaSigna R262 to run off its internal oscillator and to boot directly into the ROM-based noise reduction algorithm. The module is pre-configured to simultaneously output two different algorithm turnings: a pure close-talk output on A00, and an output that is close-talk mixed 60% towards far-talk on A01. All that is required is to supply the module with 1.8 to

3.3 VDC (requires approximately 20 mA), and to connect the analog outputs to your in-form-factor design. Power is connected to VBAT (+) and GND (-). The prototyping module configures the ROM application as summarized in Table 1 when power is applied.

A description of all test points and a complete schematic and layout is available in Appendix A.

Table 1. BelaSigna R262 PROTOTYPING MODULE LSAD CONFIGURATION

Pin Name	Preset	Description
CLOCK_SEL (SPI_CLK/GPIO0)	7	Internal clock
BOOT_SEL (SPI_CS/GPIO1)	4	Active mode Talk distance selectable between close-talk and far-talk (5 cm – 500 cm)
CHAN_SEL (SPI_SERO/GPIO2)	3	Dual output noise reduction (two single-ended analog outputs) Channel 0 as per BOOT_SEL “Start of Range” (close-talk) Channel 1 as per BOOT_SEL and ALPHA_SEL
ALPHA_SEL (SPI_SER1/GPIO3)	4	Mixer set 60% between start and end of range

**Connecting the Prototyping Module**

The analog output signals are available on AO0 (6), AO1 (7), and GNDA (-). An optional momentary push-button control can be connected between GP5 (5) and GNDD (-) that can be used to swap the two processed outputs between AO0 and AO1. The pinout for the module, along with typical connections are illustrated in Figure 2. The analog outputs of the device can be connected to your system’s analog inputs as single-ended signals using AO0 and GNDA and/or AO1 and GNDA. If the module is re-configured to output a mono, differential analog output by changing the CHAN\_SEL resistors R4 and R5, via I<sup>2</sup>C commands, or by loading a custom application, you can connect AO0 and AO1 to your system as a differential analog signal.

Note: The analog output impedance is 3 kΩ and is intended to drive a high-impedance (line-level) input, not speakers nor headphones directly. Refer to the BelaSigna R262 datasheet for more information on output stage characteristics.

You can also use the prototyping module as a digital microphone replacement outputting a stereo DMIC signal on test point GP4 (4), provided you supply an appropriate DMIC clock signal on the CLK (8) test point and re-configure the module’s CLOCK\_SEL resistive divider to match the provided clock frequency. Refer to the BelaSigna R262 datasheet for more information.

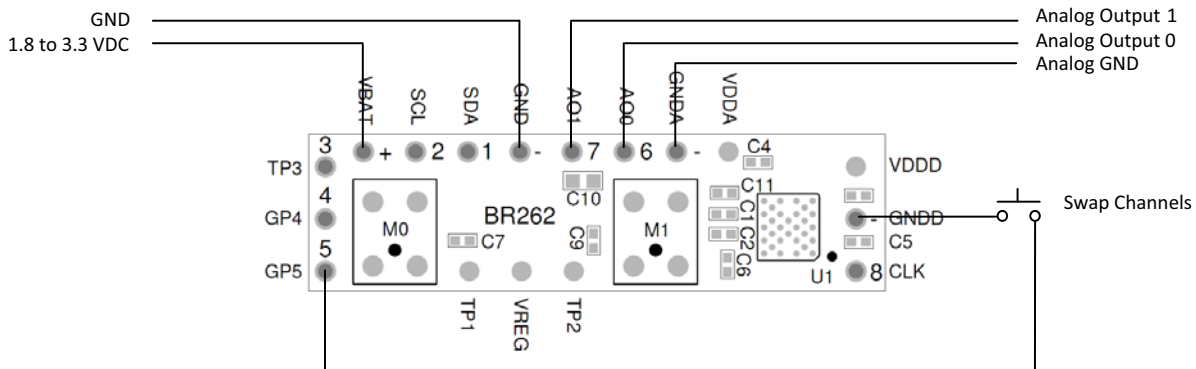

Figure 2. BelaSigna R262 Prototyping Module Typical Connections

**Operating the Prototyping Module**

The default configuration of the prototyping module provides the widest noise reduction adjustment range (close-talk to far-talk) by selecting preset 4 on the BOOT\_SEL input, and is pre-configured to simultaneously output two different algorithm tunings: a pure close-talk output on AO0, and an output that is close-talk mixed 60% towards far-talk on AO1. The processed outputs from these two algorithm tunings are available as single-ended analog outputs on AO0 – GNDA, and AO1 – GNDA. The application will swap the output channels when GP5 is momentarily pulled low. If a momentary push-button is connected

between GP5 and GNDD, pressing and releasing this button will swap the two processed outputs between AO0 and AO1.

**Close-Talk**

Close-talk mode aggressively filters noise and manages gain to pick up speech within 5 to 10 cm from the microphone array, effectively attenuating both speech and noise that is farther away. This mode is suitable for mobile handsets and radios where the speech source is very close to the microphones and the noise level can be quite high; up to 90 dB SPL. Noise reduction performance in this mode ranges from 20 to 30 dB SNR improvement (SNR-I), depending on the type of noise.

## Close-Talk Mixed 60% Towards Far-Talk

The second, mixed mode of close-talk mixed 60% towards far-talk is similar to the core near-talk mode and features excellent noise reduction in applications where the speech source is located slightly further away from the microphones; typically 50 to 100 cm. This mode is suitable for handsfree devices and performs well in noise levels up to 70 dB SPL. Expected noise reduction performance in this mode is 10 to 20 dB SNR-I, depending on the type of noise.

Refer to the AND9109/D – BelaSigna R262 Getting Started Guide for details on the different algorithm modes and performance metrics.

## Module Positioning

The speech source can come from any direction (normally in front of the microphones), as long as it is within the “working sphere” of the current algorithm mode. For close-talk mode, the mouth reference point (MRP) should be located between 5 and 10 cm from the microphones.

For close-talk mixed 60% towards far-talk, the MRP should be located between 50 and 100 cm from the microphones.

## Acoustic Design

If the prototyping module is replacing an existing microphone, the old microphone should be removed and the module should be mounted as close as possible to the original microphone location.

The device casing should be modified or manufactured such that there is an appropriate acoustic path to the two microphones on the module. Two holes roughly 0.5 to 1 mm in diameter should be drilled in the casing 10 mm apart above the sound ports of the onboard microphones. If possible a rubber or foam isolation gasket should be installed between the microphones and the device casing.

## Electrical Considerations

The analog output(s) of the module can be connected directly to any existing microphone input but keep in mind that it may be necessary to lower any existing microphone pre-amplification.

Care should be taken to properly shield the module and the analog outputs if your product involves radio frequencies. Use coaxial or shielded cable when connecting the analog outputs of the module, and if necessary, wrap the module with foil tape.

## Customizing the Prototyping Module

If you would prefer to have the default tunings to be something other than close-talk and close-talk mixed 60% towards far-talk, you can change the values of the resistive dividers on the BOOT\_SEL (R3 and R4) and ALPHA\_SEL (R7 and R8) inputs. A component placement diagram showing the locations of the various resistors is illustrated in Figure 3. Refer to the BelaSigna R262 datasheet for more information on BOOT\_SEL and ALPHA\_SEL inputs, and the resistive divider values required to achieve specific presets.

If you would like to re-configure the module to use the DMIC interface, you must supply an appropriate DMIC clock signal on the CLK test point and re-configure the module’s CLOCK\_SEL resistive divider (R1 and R2) to match the provided clock frequency. A stereo DMIC signal will be output on test point GP4. Refer to the BelaSigna R262 datasheet for more information on the supported DMIC clock frequencies, and the resistive divider values required to select them.

If you would like to re-configure the module to output a differential analog signal, you must adjust the resistive dividers on the CHAN\_SEL input (R5 and R6) to select preset 0 or preset 5. Refer to the BelaSigna R262 datasheet for more information on the CHAN\_SEL input and the resistive divider values required to achieve specific presets.

If you would like to re-configure the module to load a custom application from the EEPROM, you must load a valid custom application onto the EEPROM and remove resistor R4 to have the module boot from EEPROM. Refer to the BelaSigna R262 datasheet for more information on the BOOT\_SEL input and the resistive divider values required to achieve specific presets. Contact your local ON Semiconductor support representative for more information about custom applications.

# AND9112/D

## APPENDIX A

For your convenience, the prototyping module has many external devices are provided on through-hole test points. All of the available test points are summarized in Table 2.

**Table 2. BelaSigna R262 PROTOTYPING MODULE TEST POINT DESCRIPTIONS**

Test Point Name	Designator	Description
VBAT	+	Main module power supply (1.8 to 3.3 VDC, 20 mA)
SCL	2	I <sup>2</sup> C clock
SDA	1	I <sup>2</sup> C data
GND	-	Main module ground
AO1	7	Channel 1 analog output
AO0	6	Channel 0 analog output
GNDA	-	Analog ground (internally connected to GND)
VDDA		Internal 2.0 V power supply
VDDD		Digital power supply (internally generated)
GNDD	-	Digital ground (internally connected to GND)
CLK	8	Optional input clock
TP2		Microphone 1 test point
VREG		Internal 1.0 V power supply
TP1		Microphone 0 test point
GP5	5	Optional GPIO input (SWAP_CHAN)
GP4	4	Optional DMIC output
TP3	3	Reset

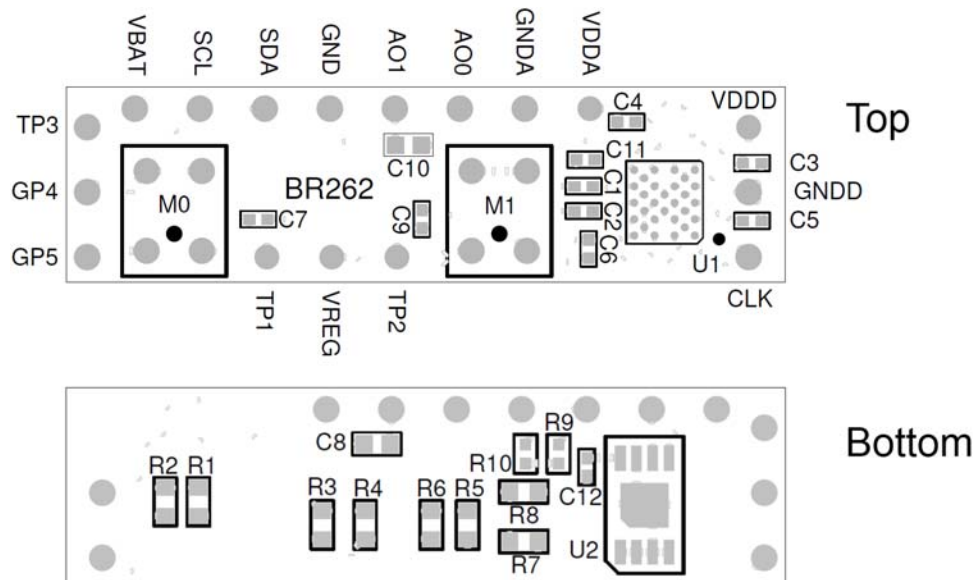

**Figure 3. Component Placement Diagram**

# AND9112/D

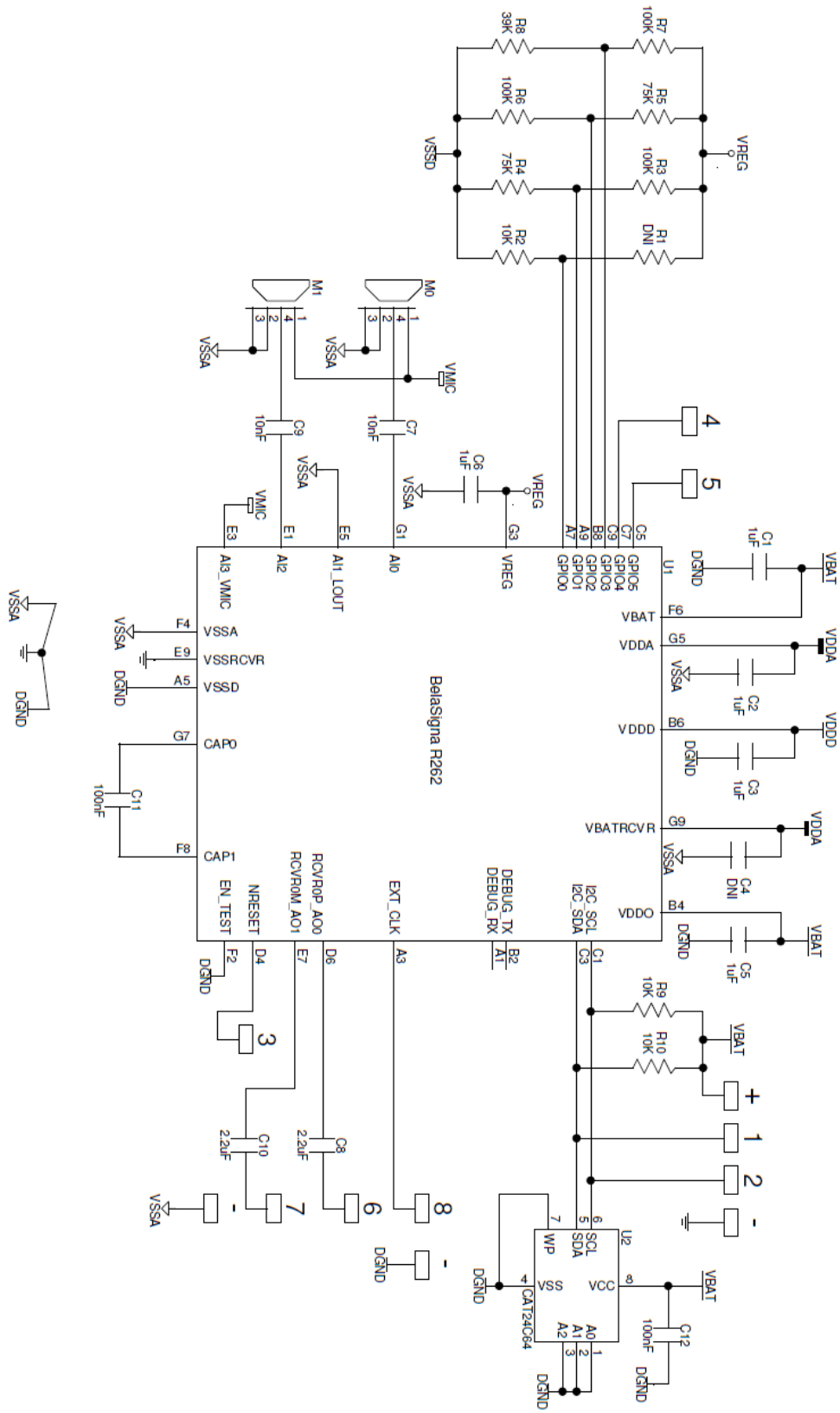
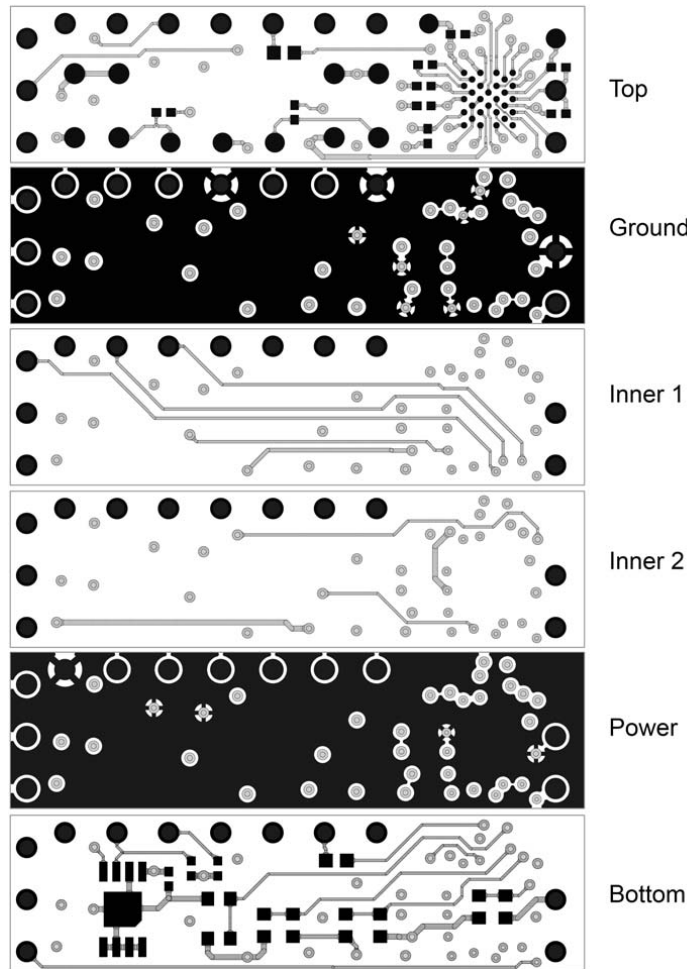

Figure 4. BelaSigna R262 Prototyping Module Schematic

## AND9112/D



**Figure 5. BelaSigna R262 Prototyping Module Layout**  
(view from top to bottom)

### Company or Product Inquiries

For more information about ON Semiconductor products or services visit our Web site at <http://onsemi.com>.

### Technical Contact Information

For technical support, email: [dsp.support@onsemi.com](mailto:dsp.support@onsemi.com)

BELASIGNA is a registered trademark of Semiconductor Components Industries, LLC (SCILLC).

ON Semiconductor and  are registered trademarks of Semiconductor Components Industries, LLC (SCILLC). SCILLC owns the rights to a number of patents, trademarks, copyrights, trade secrets, and other intellectual property. A listing of SCILLC's product/patent coverage may be accessed at [www.onsemi.com/site/pdf/Patent-Marking.pdf](http://www.onsemi.com/site/pdf/Patent-Marking.pdf). SCILLC reserves the right to make changes without further notice to any products herein. SCILLC makes no warranty, representation or guarantee regarding the suitability of its products for any particular purpose, nor does SCILLC assume any liability arising out of the application or use of any product or circuit, and specifically disclaims any and all liability, including without limitation special, consequential or incidental damages. "Typical" parameters which may be provided in SCILLC data sheets and/or specifications can and do vary in different applications and actual performance may vary over time. All operating parameters, including "Typicals" must be validated for each customer application by customer's technical experts. SCILLC does not convey any license under its patent rights nor the rights of others. SCILLC products are not designed, intended, or authorized for use as components in systems intended for surgical implant into the body, or other applications intended to support or sustain life, or for any other application in which the failure of the SCILLC product could create a situation where personal injury or death may occur. Should Buyer purchase or use SCILLC products for any such unintended or unauthorized application, Buyer shall indemnify and hold SCILLC and its officers, employees, subsidiaries, affiliates, and distributors harmless against all claims, costs, damages, and expenses, and reasonable attorney fees arising out of, directly or indirectly, any claim of personal injury or death associated with such unintended or unauthorized use, even if such claim alleges that SCILLC was negligent regarding the design or manufacture of the part. SCILLC is an Equal Opportunity/Affirmative Action Employer. This literature is subject to all applicable copyright laws and is not for resale in any manner.

### PUBLICATION ORDERING INFORMATION

#### LITERATURE FULFILLMENT:

Literature Distribution Center for ON Semiconductor  
P.O. Box 5163, Denver, Colorado 80217 USA  
Phone: 303-675-2175 or 800-344-3860 Toll Free USA/Canada  
Fax: 303-675-2176 or 800-344-3867 Toll Free USA/Canada  
Email: [orderlit@onsemi.com](mailto:orderlit@onsemi.com)

N. American Technical Support: 800-282-9855 Toll Free  
USA/Canada  
Europe, Middle East and Africa Technical Support:  
Phone: 421 33 790 2910  
Japan Customer Focus Center  
Phone: 81-3-5817-1050

ON Semiconductor Website: [www.onsemi.com](http://www.onsemi.com)

Order Literature: <http://www.onsemi.com/orderlit>

For additional information, please contact your local Sales Representative