

# ON Semiconductor

## Is Now

# onsemi™

To learn more about onsemi™, please visit our website at  
[www.onsemi.com](http://www.onsemi.com)

---

**onsemi** and **onsemi** and other names, marks, and brands are registered and/or common law trademarks of Semiconductor Components Industries, LLC dba "**onsemi**" or its affiliates and/or subsidiaries in the United States and/or other countries. **onsemi** owns the rights to a number of patents, trademarks, copyrights, trade secrets, and other intellectual property. A listing of **onsemi** product/patent coverage may be accessed at [www.onsemi.com/site/pdf/Patent-Marking.pdf](http://www.onsemi.com/site/pdf/Patent-Marking.pdf). **onsemi** reserves the right to make changes at any time to any products or information herein, without notice. The information herein is provided "as-is" and **onsemi** makes no warranty, representation or guarantee regarding the accuracy of the information, product features, availability, functionality, or suitability of its products for any particular purpose, nor does **onsemi** assume any liability arising out of the application or use of any product or circuit, and specifically disclaims any and all liability, including without limitation special, consequential or incidental damages. Buyer is responsible for its products and applications using **onsemi** products, including compliance with all laws, regulations and safety requirements or standards, regardless of any support or applications information provided by **onsemi**. "Typical" parameters which may be provided in **onsemi** data sheets and/or specifications can and do vary in different applications and actual performance may vary over time. All operating parameters, including "Typicals" must be validated for each customer application by customer's technical experts. **onsemi** does not convey any license under any of its intellectual property rights nor the rights of others. **onsemi** products are not designed, intended, or authorized for use as a critical component in life support systems or any FDA Class 3 medical devices or medical devices with a same or similar classification in a foreign jurisdiction or any devices intended for implantation in the human body. Should Buyer purchase or use **onsemi** products for any such unintended or unauthorized application, Buyer shall indemnify and hold **onsemi** and its officers, employees, subsidiaries, affiliates, and distributors harmless against all claims, costs, damages, and expenses, and reasonable attorney fees arising out of, directly or indirectly, any claim of personal injury or death associated with such unintended or unauthorized use, even if such claim alleges that **onsemi** was negligent regarding the design or manufacture of the part. **onsemi** is an Equal Opportunity/Affirmative Action Employer. This literature is subject to all applicable copyright laws and is not for resale in any manner. Other names and brands may be claimed as the property of others.

## Analog Switches Solve Many Problems within a Cell Phone

### Background

Analog switches have been available since the 60's as a component for systems designers. With the advent of ASICs and ASSPs, many designers have not experienced the real value of these devices. Today's designers may be familiar with the venerable MC14066, a workhorse that has been around for 30 years or more. The device consists of 4 independent switches that provide bilateral capabilities when "ON" and nearly infinite impedance when "OFF".

The 4066 was done in 9.0  $\mu\text{m}$  metal gate CMOS. It has a voltage rating of 3.0 to 18 V, and when switched "ON" a resistance of  $\approx 500 \Omega$ . The smallest package is a 14 pin TSSOP with approximately 32  $\text{mm}^2$  of board space occupied. If today's designer is not aware of the strides made in analog switches, many of the issues associated with the old metal gate part have been solved with today's sub-micron silicon gate CMOS in tiny transistor-like packages.

Enter the single gate solution: On Semiconductor now offers a low voltage, single version of the 4066 in a one gate package. The MC74VHC1G66DFT2 is a single switch (SPST) occupying less than 4.5  $\text{mm}^2$  in a tiny SC70/SC88A package. The device is specified from 2.0–5.5 V and offers  $< 25 \Omega$  resistance when turned "ON" and almost infinite impedance when turned off. Interestingly, the device can pass/stop either a digital or analog signal. Digital signals get passed with  $< 1.0 \text{ ns}$  delay, and very nearly no change in the signal. Analog signals get passed with less than 0.1% distortion and the device has a  $-3.0 \text{ dB}$  point of  $> 100 \text{ MHz}$ . Because of its utility, ON Semiconductor has elected to add several more devices to the portfolio including SPST, SPDT, dual SPST, DPDT, 2:1 Mux, dual DPDT functions. These are all available in tiny packages from 2.1 x 2.0 mm to 3.0 x 3.0 mm.

The following problems are presented to illustrate the use of analog switches in cell phone applications.

**Problem:** *To design an oscillator with two frequencies.* The purpose of this is to illustrate how an analog switch may be used to switch in a different crystal and have a single input to a device. The purpose might be to slow a microprocessor or DSP down to conserve power, yet still function. In this application it is assumed that the MCU has two inputs for a crystal. The NLAS4599 SPDT switch selects one of two crystals electronically under control of the MCU/DSP. Only one tiny SC70 type package is needed. The diagram doesn't show power and ground to the part for simplicity.



ON Semiconductor®

[www.onsemi.com](http://www.onsemi.com)

### APPLICATION NOTE

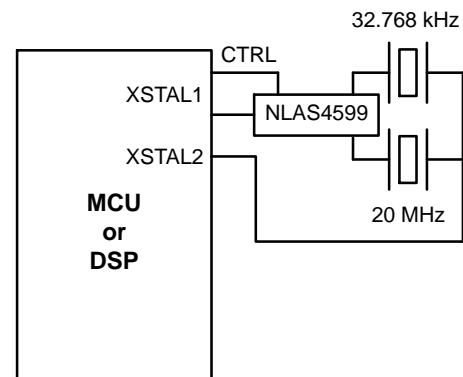

Figure 1.

**Problem:** *To cut power consumption on a system using a PLL.* A PLL operating at 1.0 GHz or more, can often draw more than 50 mA continuously. If the design is such that the frequency is constant for a period of time, say, for several minutes at a time (or longer), it is possible to use a sample and hold output where the PLL charges a capacitor, hold the charge for a period of time (e.g. 50 ms) and go back and reclose the loop. The amount of droop from nominal voltage will depend upon the capacitor used and the time the circuit is held open loop.

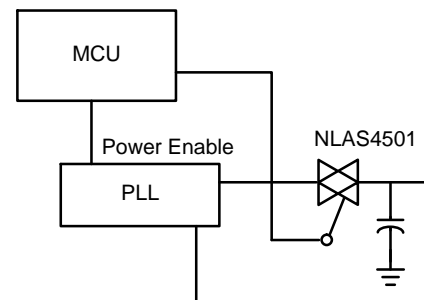

Figure 2.

**Problem:** *Improving lock time of a PLL by changing the time constant, having a fast "attack" and long hold time constant.* An analog switch can be used to change either the

resistor or capacitor that makes up the time constant for a PLL. Changing the time constant allows the loop to get close to lock very quickly then go to a long time constant for maximum PLL noise rejection.

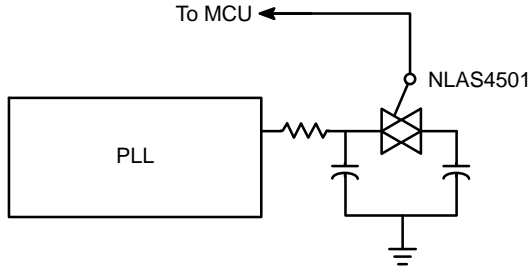

Figure 3.

*Design for testability.* Cell phones are complete communication systems built into tiny housings. They are comprised of I/O, memory, a CPU and firmware. With firmware becoming such a large part of the design, it is crucial that the designer be able to enable software debugging, and create a system that can be analyzed for field problems. The analog switch permits the designer to re-route some of the I/Os to create a new path for analysis. For purposes of illustration, I will show two I/Os that need re-routing to be tested by an external tester. I will make the assumption that the designer cannot afford to give up 2 I/O pins. Analog switches then make the perfect solution. They introduce nearly zero delay time, cause almost no distortion to the signal, and all the configuration to be switched by an external pin. The NLAS4599 is a Single Pole Double Throw (SPDT) switch, that will allow the normal configuration to

be wired through. If the control pin is grounded through a resistor, the when an external plug is presented, it needs to take the (assumed) 3.0 V supply and route it out to the control pin, and then it will have the 2 I/O pins available to use. The result is only 8.0 mm<sup>2</sup> of board space used, with near zero delay and no degradation to the signal. When the external connector is plugged in, the enable changes the circuit over and the 2 I/O pins are routed from their normal position within the circuit, to be used as external pins for test.

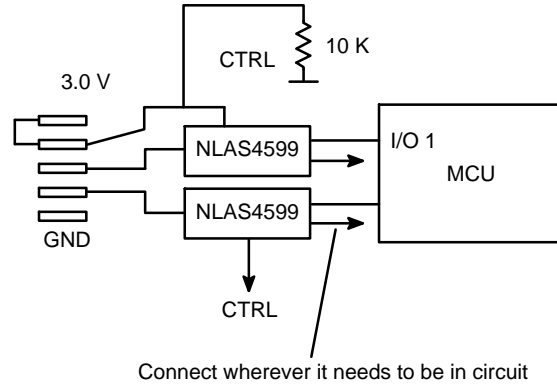

Figure 4.

**Conclusion**

ON Semiconductor offers more than a dozen analog switches in tiny packages varying from SC70 and TSOP-5 to a 3.0 x 3.0 mm QFN (Quad Flat No-lead) 16 pin device. The complete list is shown following. The ideas shown here and many more can be implemented by one or more of these devices.

Device	Function	Package
NLAS4501	1-SPST	SC88A, TSOP-5
NLAS4599	1-SPDT	SC88, TSOP-6
NLAS3157	1-SPDT	SC88
NLAS323	2-SPST, Pos EN	US8
NLAS324	2-SPST, Neg EN	US8
NLAS325	2-SPST, 1 Pos, 1 Neg	US8
NLAS1053	1-2:1 Mux	US8
NLAS4592	2-Independent SPDT	Micro-10
NLAS44599	2-Independent DPDT	QFN

SPST = Single Pole Single Throw, SPDT = Single Pole Double Throw, DPDT = Double Pole Double Throw

SC88 is a 5/6 lead package that has a 2.1 x 2.0 mm footprint

TSOP-5/5 is a 5/6 lead package with a 3.0 x 2.0 footprint

US8 is an 8 lead package with a 3 x 2 mm footprint

Micro-10 is a 10 lead package with a 3 x 5 mm footprint

QFN-16 is a 16 lead package with a 3 x 3 mm footprint

ON Semiconductor and the  are registered trademarks of Semiconductor Components Industries, LLC (SCILLC) or its subsidiaries in the United States and/or other countries. SCILLC owns the rights to a number of patents, trademarks, copyrights, trade secrets, and other intellectual property. A listing of SCILLC's product/patent coverage may be accessed at [www.onsemi.com/site/pdf/Patent-Marking.pdf](http://www.onsemi.com/site/pdf/Patent-Marking.pdf). SCILLC reserves the right to make changes without further notice to any products herein. SCILLC makes no warranty, representation or guarantee regarding the suitability of its products for any particular purpose, nor does SCILLC assume any liability arising out of the application or use of any product or circuit, and specifically disclaims any and all liability, including without limitation special, consequential or incidental damages. "Typical" parameters which may be provided in SCILLC data sheets and/or specifications can and do vary in different applications and actual performance may vary over time. All operating parameters, including "Typicals" must be validated for each customer application by customer's technical experts. SCILLC does not convey any license under its patent rights nor the rights of others. SCILLC products are not designed, intended, or authorized for use as components in systems intended for surgical implant into the body, or other applications intended to support or sustain life, or for any other application in which the failure of the SCILLC product could create a situation where personal injury or death may occur. Should Buyer purchase or use SCILLC products for any such unintended or unauthorized application, Buyer shall indemnify and hold SCILLC and its officers, employees, subsidiaries, affiliates, and distributors harmless against all claims, costs, damages, and expenses, and reasonable attorney fees arising out of, directly or indirectly, any claim of personal injury or death associated with such unintended or unauthorized use, even if such claim alleges that SCILLC was negligent regarding the design or manufacture of the part. SCILLC is an Equal Opportunity/Affirmative Action Employer. This literature is subject to all applicable copyright laws and is not for resale in any manner.

## PUBLICATION ORDERING INFORMATION

### LITERATURE FULFILLMENT:

Literature Distribution Center for ON Semiconductor  
P.O. Box 5163, Denver, Colorado 80217 USA  
**Phone:** 303-675-2175 or 800-344-3860 Toll Free USA/Canada  
**Fax:** 303-675-2176 or 800-344-3867 Toll Free USA/Canada  
**Email:** [orderlit@onsemi.com](mailto:orderlit@onsemi.com)

**N. American Technical Support:** 800-282-9855 Toll Free  
USA/Canada  
**Europe, Middle East and Africa Technical Support:**  
Phone: 421 33 790 2910  
**Japan Customer Focus Center**  
Phone: 81-3-5817-1050

**ON Semiconductor Website:** [www.onsemi.com](http://www.onsemi.com)  
**Order Literature:** <http://www.onsemi.com/orderlit>  
For additional information, please contact your local  
Sales Representative