

ON Semiconductor

Is Now

The logo for onsemi, featuring the word "onsemi" in a dark teal, lowercase, sans-serif font. The letter "i" is stylized with a white dot and a teal vertical bar. A small orange triangle is positioned above the top right of the "i". A trademark symbol (TM) is located to the right of the logo.

To learn more about onsemi™, please visit our website at
www.onsemi.com

onsemi and **onsemi** and other names, marks, and brands are registered and/or common law trademarks of Semiconductor Components Industries, LLC dba "**onsemi**" or its affiliates and/or subsidiaries in the United States and/or other countries. **onsemi** owns the rights to a number of patents, trademarks, copyrights, trade secrets, and other intellectual property. A listing of **onsemi** product/patent coverage may be accessed at www.onsemi.com/site/pdf/Patent-Marking.pdf. **onsemi** reserves the right to make changes at any time to any products or information herein, without notice. The information herein is provided "as-is" and **onsemi** makes no warranty, representation or guarantee regarding the accuracy of the information, product features, availability, functionality, or suitability of its products for any particular purpose, nor does **onsemi** assume any liability arising out of the application or use of any product or circuit, and specifically disclaims any and all liability, including without limitation special, consequential or incidental damages. Buyer is responsible for its products and applications using **onsemi** products, including compliance with all laws, regulations and safety requirements or standards, regardless of any support or applications information provided by **onsemi**. "Typical" parameters which may be provided in **onsemi** data sheets and/or specifications can and do vary in different applications and actual performance may vary over time. All operating parameters, including "Typicals" must be validated for each customer application by customer's technical experts. **onsemi** does not convey any license under any of its intellectual property rights nor the rights of others. **onsemi** products are not designed, intended, or authorized for use as a critical component in life support systems or any FDA Class 3 medical devices or medical devices with a same or similar classification in a foreign jurisdiction or any devices intended for implantation in the human body. Should Buyer purchase or use **onsemi** products for any such unintended or unauthorized application, Buyer shall indemnify and hold **onsemi** and its officers, employees, subsidiaries, affiliates, and distributors harmless against all claims, costs, damages, and expenses, and reasonable attorney fees arising out of, directly or indirectly, any claim of personal injury or death associated with such unintended or unauthorized use, even if such claim alleges that **onsemi** was negligent regarding the design or manufacture of the part. **onsemi** is an Equal Opportunity/Affirmative Action Employer. This literature is subject to all applicable copyright laws and is not for resale in any manner. Other names and brands may be claimed as the property of others.



Two New Analog Switches Set Standards for Space Efficiency

Prepared by: Fred Zlotnick
ON Semiconductor

APPLICATION NOTE

INTRODUCTION

Analog switches that provide analog and digital switching to circuit designers, have been around for more than 30 years. One of the most popular switches has been the 4053, a triple Single-Pole Double-Throw (SPDT) switch in a 16-pin package. The most aggressive common package for this device is the TSSOP-16 which occupies 32 mm² of board space or 10.5 mm² per switch.

The hand-held wireless phenomenon is driving the need to get more functionality into even smaller spaces. In response, ON Semiconductor released more than 30 single-gate switches that supply exactly the right bit of logic just where it is needed. These products were released in industry standard SC88A/SOT-353 packages which occupy just over 4 mm². These devices are all five leads and provide standard logic functions. An example is the MC74VHC1G66, a Single-Pole, Single-Throw (SPST) analog switch.

The NLAS4599

The new NLAS4599 device is a single SPDT switch, one-third the size of the venerable 4053, contained in an aggressive 0.6 μ CMOS technology. It provides voltage

breakdown greater than 7.0 V, low R_{on}, and excellent high frequency response. The NLAS4599 sets a new standard in space efficiency. It occupies 4. mm² and provides the same functionality as one-third of a 4053. Compared to the 4053, the NLAS4599 is 2.5 times more space efficient. This is a real boon to designers, who need to put as much functionality as possible into every square inch.

Examples

1. Design a crystal-controlled oscillator that functions at 32 KHz for minimum power consumption and 16 MHz for performance in a battery-operated environment. The new NL27WZU04 provides two unbuffered gates in a single 4 mm² package. One gate is an oscillator; the second gate is a buffer. The NLAS4599 is used to switch crystals. A single control line (assumed to come from a microcontroller) controls the frequency. When the unit is near idle, the clock is 32 KHz and the microcontroller/DSP functions at minimum power consumption. When speed (performance) is required, the clock switches to 16 MHz.

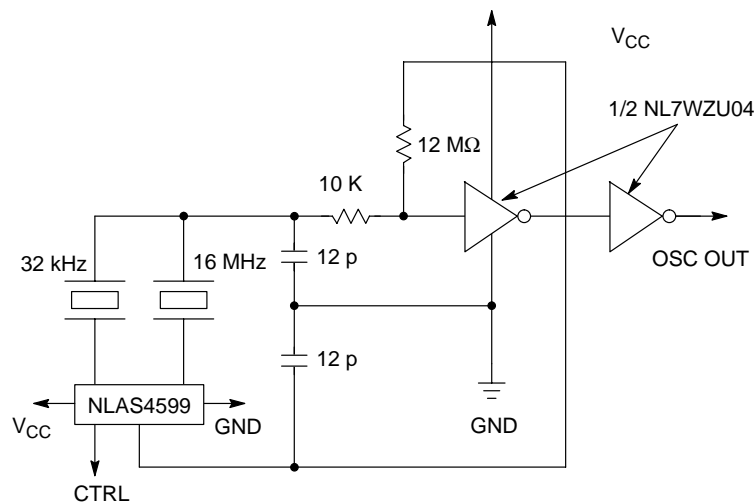

This circuit provides dual clock rates under microprocessor control and occupies minimal board space.

Figure 1. Dual Frequency Oscillator

2. Switch between two audio signals in a single phone, one from a digital baseband detector, the other from an analog baseband detector, to drive the final audio output to an ear piece. In this example, it is assumed that a multifunctional cell phone has both an analog detector and a digital detector, one of which must be selected to drive the final audio output to the ear piece. The NLAS4599 selects the digital or analog detector output, presenting very low impedance to the driver amplifier for the selected device and very high impedance to the deselected device.

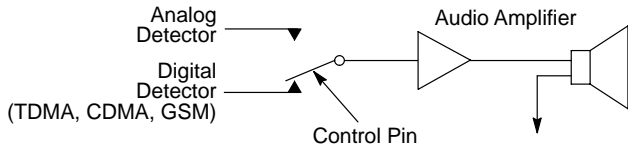

Figure 2. Switching Between Two Audio Signals

These two examples show how the NLAS4599 can be used to select from two outputs, such as crystals and digital, or analog signals under microprocessor control. The NLAS4599 will stop or pass any signal between GND and V_{CC}, either digital or analog, and preserve its voltage level. The device is usable beyond 100 MHz, since the 3 dB point is beyond 150 MHz.

The NLAS44599

ON Semiconductor has designed a new device in even smaller spaces with more functionality. The device is placed in a new package type, being made available and accepted by JEDEC, called the Fine Pitch Quad Flat No Lead package (QFN). The specification falls under JEDEC MO-220, dated January 2000. It calls for packages whose body sizes range from 3 x 3 mm to 8 x 8 mm. The lead count goes from 4 to 56. The thickness (height off the board) is a maximum of 1 mm.

ON Semiconductor put a new device, called the NLAS44599, in a 3 x 3 package. The new device consists of 16 leads with a 0.5 mm pitch. Since the package is “no lead,” there are no co-planarity issues and no solder bumps. The user simply applies solder paste to the circuit board, places the QFN, and uses IR re-flow soldering to complete the mounting.

With this concept, we were able to put the equivalent of four of the NLAS4599 SPDT devices into a 9 mm² package. Compared to the 4053 in TSSOP, this device is more than four times as space efficient. With 16 pins, we were able to construct two independent DPDT switches. These devices are inherently bilateral. Signals can flow in either direction and, once turned on, these devices offer almost zero propagation delay.

See Figure 3 for an example of how to switch LVDS signals.

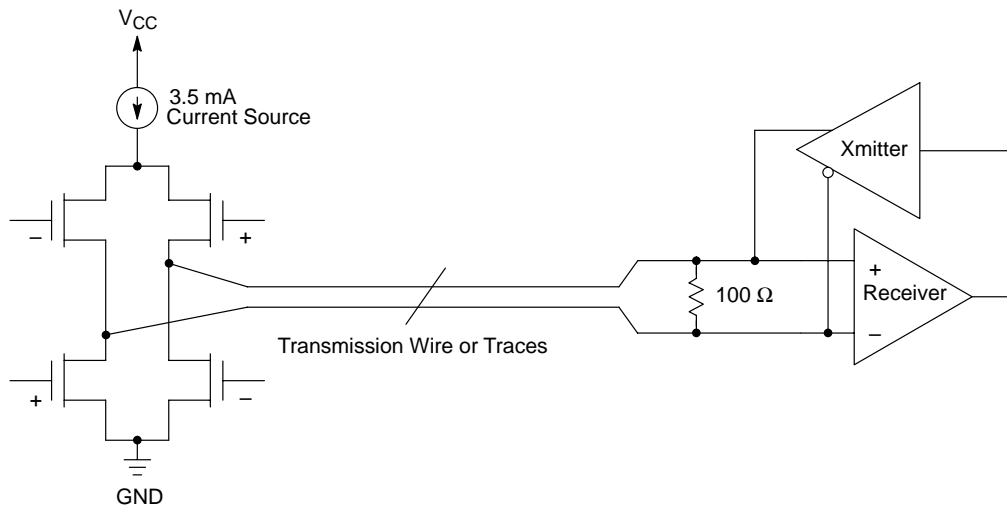

Figure 3. Low Voltage Differential Signaling

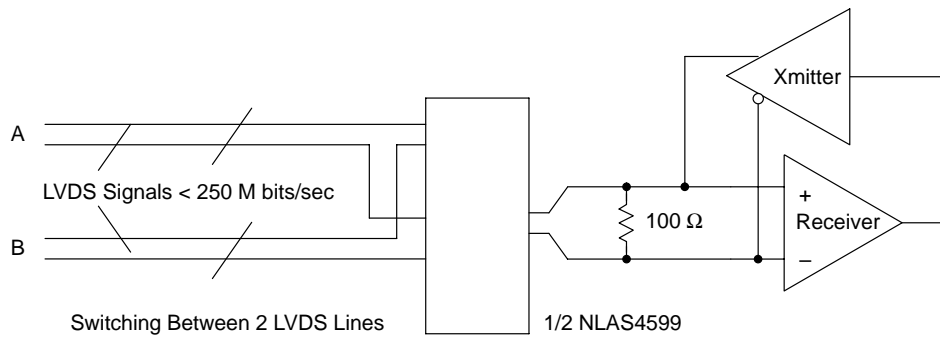

Figure 4. Switching Between Two LVDS Lines

Low Voltage Differential Signaling

Low Voltage Differential Signaling (LVDS) is becoming a very popular scheme for point-to-point transfer of signals up to 200 MHz and for distances less than 25 meters. The LVDS signals fall under EIA-644 specifications. The LVDS signal sits at a dc. level of about 1.25 volts and is guaranteed to fall between 100 mV and 750 mV of differential swing. Since the NLAS44599 provides very small insertion loss, owing to frequency roll-off or series resistance attenuation, it makes an ideal switch for differential pairs. The NLAS44599 consists of two independent DPST switches; therefore, it only takes one of this device to select between two LVDS signals going to a single transceiver.

Figure 4 shows one-half of the mm^2 device used to switch between two differential pairs. No biasing is required since the LVDS specification calls for the signal to be at

roughly 1.25 V, well within the requirement of the NLAS44599. The other half of the device may be used to provide similar or entirely different switching functions. Other differential signals such as Ethernet signals on a Category 5 wire, ECL signals within the frequency range of this device, and professional audio signals (600 Ω balanced) may be switched in a similar manner.

Summary

On Semiconductor is bringing new, extremely space-efficient analog switches to the marketplace. These devices will be used creatively by our customers to solve difficult problems, in small spaces. Both new products, the NLAS4599 and the NLAS44599, represent step functions in space efficiency and functionality over existing solutions.

ON Semiconductor and  are trademarks of Semiconductor Components Industries, LLC (SCILLC). SCILLC reserves the right to make changes without further notice to any products herein. SCILLC makes no warranty, representation or guarantee regarding the suitability of its products for any particular purpose, nor does SCILLC assume any liability arising out of the application or use of any product or circuit, and specifically disclaims any and all liability, including without limitation special, consequential or incidental damages. "Typical" parameters which may be provided in SCILLC data sheets and/or specifications can and do vary in different applications and actual performance may vary over time. All operating parameters, including "Typicals" must be validated for each customer application by customer's technical experts. SCILLC does not convey any license under its patent rights nor the rights of others. SCILLC products are not designed, intended, or authorized for use as components in systems intended for surgical implant into the body, or other applications intended to support or sustain life, or for any other application in which the failure of the SCILLC product could create a situation where personal injury or death may occur. Should Buyer purchase or use SCILLC products for any such unintended or unauthorized application, Buyer shall indemnify and hold SCILLC and its officers, employees, subsidiaries, affiliates, and distributors harmless against all claims, costs, damages, and expenses, and reasonable attorney fees arising out of, directly or indirectly, any claim of personal injury or death associated with such unintended or unauthorized use, even if such claim alleges that SCILLC was negligent regarding the design or manufacture of the part. SCILLC is an Equal Opportunity/Affirmative Action Employer.

PUBLICATION ORDERING INFORMATION

NORTH AMERICA Literature Fulfillment:

Literature Distribution Center for ON Semiconductor
 P.O. Box 5163, Denver, Colorado 80217 USA
Phone: 303-675-2175 or 800-344-3860 Toll Free USA/Canada
Fax: 303-675-2176 or 800-344-3867 Toll Free USA/Canada
Email: ONlit@hibbertco.com
 Fax Response Line: 303-675-2167 or 800-344-3810 Toll Free USA/Canada

N. American Technical Support: 800-282-9855 Toll Free USA/Canada

EUROPE: LDC for ON Semiconductor – European Support

German Phone: (+1) 303-308-7140 (Mon-Fri 2:30pm to 7:00pm CET)
Email: ONlit-german@hibbertco.com
French Phone: (+1) 303-308-7141 (Mon-Fri 2:00pm to 7:00pm CET)
Email: ONlit-french@hibbertco.com
English Phone: (+1) 303-308-7142 (Mon-Fri 12:00pm to 5:00pm GMT)
Email: ONlit@hibbertco.com

EUROPEAN TOLL-FREE ACCESS*: 00-800-4422-3781

*Available from Germany, France, Italy, UK, Ireland

CENTRAL/SOUTH AMERICA:

Spanish Phone: 303-308-7143 (Mon-Fri 8:00am to 5:00pm MST)
Email: ONlit-spanish@hibbertco.com
Toll-Free from Mexico: Dial 01-800-288-2872 for Access –
 then Dial 866-297-9322

ASIA/PACIFIC: LDC for ON Semiconductor – Asia Support

Phone: 1-303-675-2121 (Tue-Fri 9:00am to 1:00pm, Hong Kong Time)
Toll Free from Hong Kong & Singapore:
001-800-4422-3781
Email: ONlit-asia@hibbertco.com

JAPAN: ON Semiconductor, Japan Customer Focus Center

4-32-1 Nishi-Gotanda, Shinagawa-ku, Tokyo, Japan 141-0031
Phone: 81-3-5740-2700
Email: r14525@onsemi.com

ON Semiconductor Website: <http://onsemi.com>

For additional information, please contact your local Sales Representative.