

ON Semiconductor

Is Now

onsemi™

To learn more about onsemi™, please visit our website at
www.onsemi.com

onsemi and **onsemi** and other names, marks, and brands are registered and/or common law trademarks of Semiconductor Components Industries, LLC dba "**onsemi**" or its affiliates and/or subsidiaries in the United States and/or other countries. **onsemi** owns the rights to a number of patents, trademarks, copyrights, trade secrets, and other intellectual property. A listing of **onsemi** product/patent coverage may be accessed at www.onsemi.com/site/pdf/Patent-Marking.pdf. **onsemi** reserves the right to make changes at any time to any products or information herein, without notice. The information herein is provided "as-is" and **onsemi** makes no warranty, representation or guarantee regarding the accuracy of the information, product features, availability, functionality, or suitability of its products for any particular purpose, nor does **onsemi** assume any liability arising out of the application or use of any product or circuit, and specifically disclaims any and all liability, including without limitation special, consequential or incidental damages. Buyer is responsible for its products and applications using **onsemi** products, including compliance with all laws, regulations and safety requirements or standards, regardless of any support or applications information provided by **onsemi**. "Typical" parameters which may be provided in **onsemi** data sheets and/or specifications can and do vary in different applications and actual performance may vary over time. All operating parameters, including "Typicals" must be validated for each customer application by customer's technical experts. **onsemi** does not convey any license under any of its intellectual property rights nor the rights of others. **onsemi** products are not designed, intended, or authorized for use as a critical component in life support systems or any FDA Class 3 medical devices or medical devices with a same or similar classification in a foreign jurisdiction or any devices intended for implantation in the human body. Should Buyer purchase or use **onsemi** products for any such unintended or unauthorized application, Buyer shall indemnify and hold **onsemi** and its officers, employees, subsidiaries, affiliates, and distributors harmless against all claims, costs, damages, and expenses, and reasonable attorney fees arising out of, directly or indirectly, any claim of personal injury or death associated with such unintended or unauthorized use, even if such claim alleges that **onsemi** was negligent regarding the design or manufacture of the part. **onsemi** is an Equal Opportunity/Affirmative Action Employer. This literature is subject to all applicable copyright laws and is not for resale in any manner. Other names and brands may be claimed as the property of others.

AN-5068

FAN5904 Reference Schematics Design

Summary

This document describes Fairchild's recommended schematics design for FAN5904 in an application. The schematics in this document may not be exactly the same as those used in the evaluation board as extra components are added to evaluation boards for measurement purposes. The recommended schematics in this document are for the final application.

Schematics Design Principles

Figure 1 is the recommended schematics design for FAN5904. The purposes of the external components are explained here:

1. **C9** represents a capacitor at the battery connection. It compensates the battery lead inductance. It is optional and not part of FAN5904 application. Depending on the system design, this capacitor may not be necessary.
2. **C10** is the main input capacitor for FAN5904 decoupling. This capacitor must be placed close to PVIN and grounded to PGND of the device. When placing C10, ensure the current first reaches PVIN, then to AVIN; even though PVIN and AVIN are connected together. PVIN pins are the input pins of the power train that carries high current. C10 needs to be close to PVIN to minimize input voltage variation.
3. **C8** is an RF capacitor that filters high-frequency variation on the power line. Its purpose is to provide low impedance to ground for high-frequency noise and prevent either high-frequency noise coupled into the RF DC-DC regulator from power input or to prevent it going out from PVIN. This capacitor should be placed close to PVIN, between C10 and PVIN, and as close as possible to PVIN to minimize the current loop. It needs to be grounded to PGND with shortest distance.
4. **C11** is same as C8. It is an RF capacitor used at RF DC-DC output end. For both C8 and C11, 68 pF is recommended according to Fairchild's experiment but the values should be determined by trials because the frequency with lowest impedance is determined by the RF capacitor values, trace inductance, and other components on the trace. Different PCB layouts create different lowest impedance frequency points. Table 1 is

a reference of capacitors to provide lowest impedance at between 850 MHz to 900 MHz, but these values may not be accurate for all PCB layouts. These capacitors are needed if the GND plane cannot be optimized for the RF DC-DC regulator. With optimized ground layout, such as a large solid ground right under the RF DC-DC regulator, these capacitors may not benefit system performance. Fairchild recommends adding these capacitors if PCB space allows.

5. **C12** is the output capacitor. FAN5904 is designed to work with 4.7 μ F output capacitor. Higher value slows down the output transition and lower value yields to higher output voltage ripple.
6. **C13** represents decoupling capacitors for PA. It is not part of FAN5904 application design. Values should be recommended by PA vendors or be determined by system design.
7. **R5, R6, R7, and R8** are optional input resistors for control inputs. These resistors damp noise going into the RF DC-DC device. In general, these resistors are not necessary.
8. **R9** and **C14** form a low-pass filter to minimize noise going to VCON. VCON is a sensitive input pin that controls output voltage. Proper filtering is necessary to ensure clean output voltage. The resistor and capacitor values should be determined by the system design.

When laying out the FAN5904; C10, C8, C11, and C12 should be connected to PGND (A1, B1) with the shortest and widest trace on the top layer. This minimizes ground connection inductance to ensure stable RF DC-DC output. AGND (C1) can be connected to PGND at the ground plane in the inner PCB layer.

To prevent noise coupling in mobile applications, it is recommended to make a shielding can for RF DC-DC circuit block only. Sharing one shielding can for RF DC-DC and other devices may cause noise reflecting from metal shielding to couple from one device to the others.

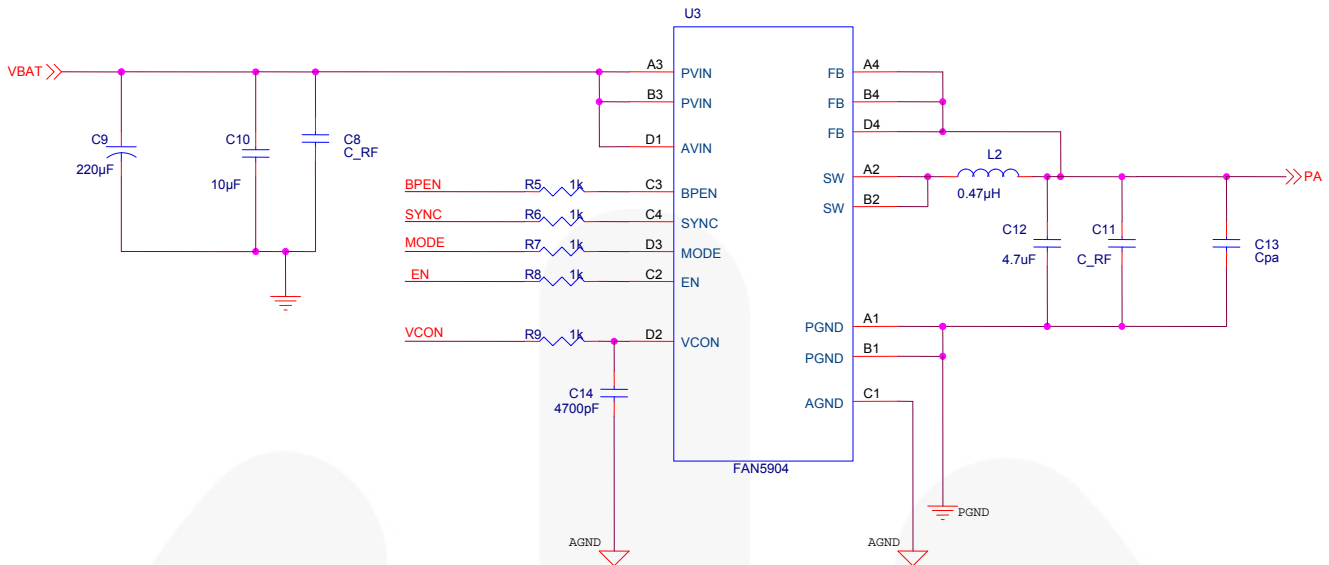

Figure 1. Application Schematic

Table 1. Recommended FR Capacitors for WCDMA Band V

f _{RESONANCE} (MHz)	Size (Metric)	Value (pF)	Material Voltage (V)	MFG	Part Number
898	1005 (H=0.5 mm)	82 ±5%	COG 25	Murata	GRM1555C1E820JA01
898	1005 (H=0.3 mm)	82 ±5%	COG 50	Murata	GRM1555C1E820JA01
885	0201 (H=0.3 mm)	150 ±10%	X7R 16	Murata	GRM033R71C15KA01
885	0201 (H=0.3 mm)	150 ±10%	X7R 25	Murata	GRM033R71E15KA01

Table 2. Bill of Materials

Reference No.	Value	Package	Function	Usage
C10	10 µF	0402	V _{IN} Bypassing	Required
C8	TBD	0201 / 0402	V _{IN} Noise Filtering	Recommended
C11	TBD	0201 / 0402	V _{OUT} Noise Filtering	Recommended
C12	4.7 µF	0402	V _{OUT} Bypassing	Required
C14	4700 pF	0402	V _{CON} Noise Filtering	Required
L2	0.47 µH or 1.0 µH	VLS201610MNT-R47N VLS252010MNT-R47N VLS201610MNT-1R0N VLS252010MNT-1R0N	Output Inductor	Required
R9	1 kΩ	0402	Damping	Required
R5	1 kΩ	0402	Damping	Optional
R6	1 kΩ	0402	Damping	Optional
R7	1 kΩ	0402	Damping	Optional
R8	1 kΩ	0402	Damping	Optional
C9	220 µF	AVX TAJE227K010RNJ	V _{IN} Bypassing	Optional
C13	TBD	0402	PA V _{IN} Bypassing	Required

Related Resources

[FAN5903 — 600 mA Buck Converter for 3G, 3.5G, 4G RFPAs](#)

[FAN5904 — Multi-Mode Buck Converter for GSM/EDGE, 3G, and 4G PAs](#)

[AN-9045 — WLCSP Assembly Guidelines](#)

DISCLAIMER

FAIRCHILD SEMICONDUCTOR RESERVES THE RIGHT TO MAKE CHANGES WITHOUT FURTHER NOTICE TO ANY PRODUCTS HEREIN TO IMPROVE RELIABILITY, FUNCTION, OR DESIGN. FAIRCHILD DOES NOT ASSUME ANY LIABILITY ARISING OUT OF THE APPLICATION OR USE OF ANY PRODUCT OR CIRCUIT DESCRIBED HEREIN; NEITHER DOES IT CONVEY ANY LICENSE UNDER ITS PATENT RIGHTS, NOR THE RIGHTS OF OTHERS.

LIFE SUPPORT POLICY

FAIRCHILD'S PRODUCTS ARE NOT AUTHORIZED FOR USE AS CRITICAL COMPONENTS IN LIFE SUPPORT DEVICES OR SYSTEMS WITHOUT THE EXPRESS WRITTEN APPROVAL OF THE PRESIDENT OF FAIRCHILD SEMICONDUCTOR CORPORATION.

As used herein:

1. Life support devices or systems are devices or systems which, (a) are intended for surgical implant into the body, or (b) support or sustain life, or (c) whose failure to perform when properly used in accordance with instructions for use provided in the labeling, can be reasonably expected to result in significant injury to the user.
2. A critical component is any component of a life support device or system whose failure to perform can be reasonably expected to cause the failure of the life support device or system, or to affect its safety or effectiveness.