

CERAMIC DIP 24
CASE 125AT
ISSUE O

DATE 30 JUN 2014

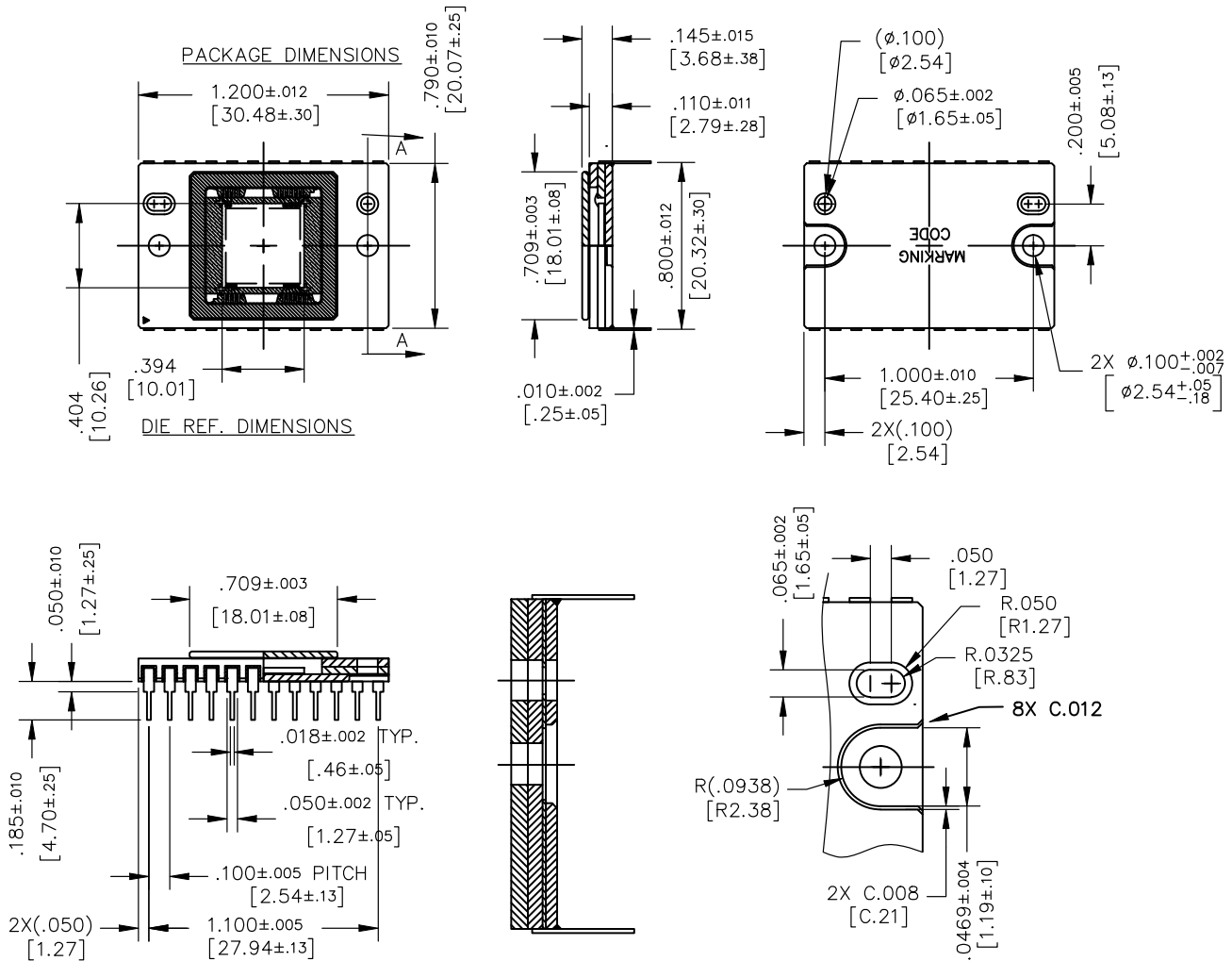

Notes:
 1. Cover glass is manually placed and visually aligned over die – Location accuracy is not guaranteed.

Dimensions in: Inches [mm]

DOCUMENT NUMBER:	98AON86710F	Electronic versions are uncontrolled except when accessed directly from the Document Repository. Printed versions are uncontrolled except when stamped "CONTROLLED COPY" in red.
DESCRIPTION:	CERAMIC DIP 24	PAGE 1 OF 2

ON Semiconductor and ON are trademarks of Semiconductor Components Industries, LLC dba ON Semiconductor or its subsidiaries in the United States and/or other countries. ON Semiconductor reserves the right to make changes without further notice to any products herein. ON Semiconductor makes no warranty, representation or guarantee regarding the suitability of its products for any particular purpose, nor does ON Semiconductor assume any liability arising out of the application or use of any product or circuit, and specifically disclaims any and all liability, including without limitation special, consequential or incidental damages. ON Semiconductor does not convey any license under its patent rights nor the rights of others.

CERAMIC DIP 24
CASE 125AT
ISSUE O

DATE 30 JUN 2014

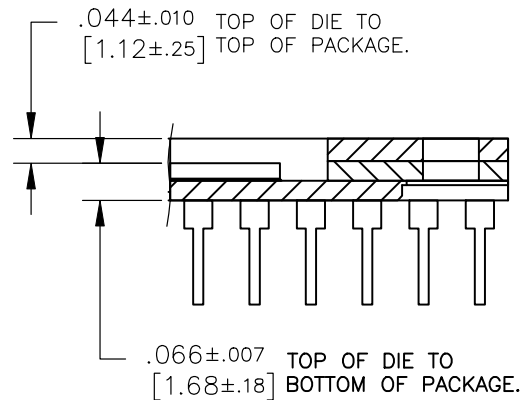
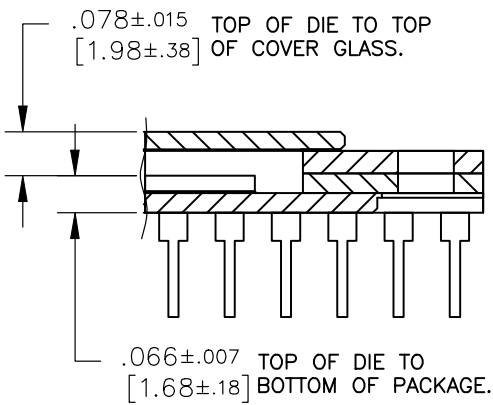
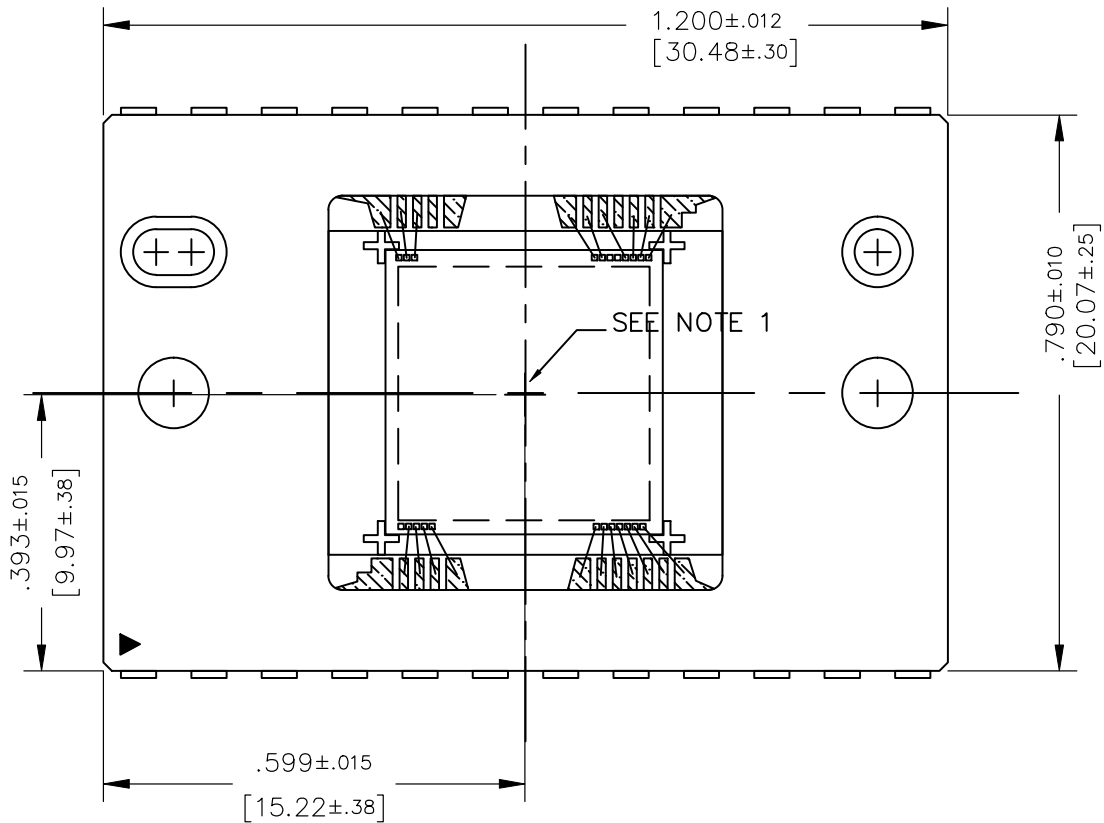

NOTES:

1. CENTER OF IMAGE AREA IS OFFSET FROM CENTER OF PACKAGE BY (-0.02,-0.06)MM NOMINAL.
2. DIE IS ALIGNED WITHIN +/- 2 DEGREE OF ANY PACKAGE CAVITY EDGE.

Dimensions in: Inches [mm]

DOCUMENT NUMBER:	98AON86710F	Electronic versions are uncontrolled except when accessed directly from the Document Repository. Printed versions are uncontrolled except when stamped "CONTROLLED COPY" in red.
DESCRIPTION:	CERAMIC DIP 24	PAGE 2 OF 2

ON Semiconductor and  are trademarks of Semiconductor Components Industries, LLC dba ON Semiconductor or its subsidiaries in the United States and/or other countries. ON Semiconductor reserves the right to make changes without further notice to any products herein. ON Semiconductor makes no warranty, representation or guarantee regarding the suitability of its products for any particular purpose, nor does ON Semiconductor assume any liability arising out of the application or use of any product or circuit, and specifically disclaims any and all liability, including without limitation special, consequential or incidental damages. ON Semiconductor does not convey any license under its patent rights nor the rights of others.