

TL494, NCV494

SWITCHMODE™ Pulse Width Modulation Control Circuit

The TL494 is a fixed frequency, pulse width modulation control circuit designed primarily for SWITCHMODE power supply control.

Features

- Complete Pulse Width Modulation Control Circuitry
- On-Chip Oscillator with Master or Slave Operation
- On-Chip Error Amplifiers
- On-Chip 5.0 V Reference
- Adjustable Deadtime Control
- Uncommitted Output Transistors Rated to 500 mA Source or Sink
- Output Control for Push-Pull or Single-Ended Operation
- Undervoltage Lockout
- NCV Prefix for Automotive and Other Applications Requiring Site and Control Changes
- Pb-Free Packages are Available*

MAXIMUM RATINGS (Full operating ambient temperature range applies, unless otherwise noted.)

| Rating | Symbol | Value | Unit |
|--|------------------------|--|--------------------|
| Power Supply Voltage | V_{CC} | 42 | V |
| Collector Output Voltage | V_{C1} , V_{C2} | 42 | V |
| Collector Output Current (Each transistor) (Note 1) | I_{C1} , I_{C2} | 500 | mA |
| Amplifier Input Voltage Range | V_{IR} | -0.3 to +42 | V |
| Power Dissipation @ $T_A \leq 45^\circ\text{C}$ | P_D | 1000 | mW |
| Thermal Resistance, Junction-to-Ambient | $R_{\theta JA}$ | 80 | $^\circ\text{C/W}$ |
| Operating Junction Temperature | T_J | 125 | $^\circ\text{C}$ |
| Storage Temperature Range | T_{stg} | -55 to +125 | $^\circ\text{C}$ |
| Operating Ambient Temperature Range | T_A | -40 to +125 0 to +70 -40 to +85 -40 to +125 | $^\circ\text{C}$ |
| Derating Ambient Temperature | T_A | 45 | $^\circ\text{C}$ |

Maximum ratings are those values beyond which device damage can occur. Maximum ratings applied to the device are individual stress limit values (not normal operating conditions) and are not valid simultaneously. If these limits are exceeded, device functional operation is not implied, damage may occur and reliability may be affected.

1. Maximum thermal limits must be observed.



ON Semiconductor®

<http://onsemi.com>

MARKING DIAGRAMS

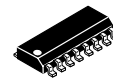

**SOIC-16
D SUFFIX
CASE 751B**

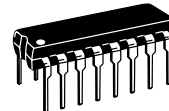
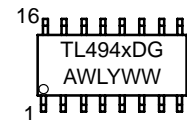

**PDIP-16
N SUFFIX
CASE 648**

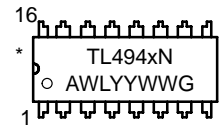

x = B, C or I
A = Assembly Location
WL = Wafer Lot
YY, Y = Year
WW, W = Work Week
G = Pb-Free Package

*This marking diagram also applies to NCV494.

PIN CONNECTIONS

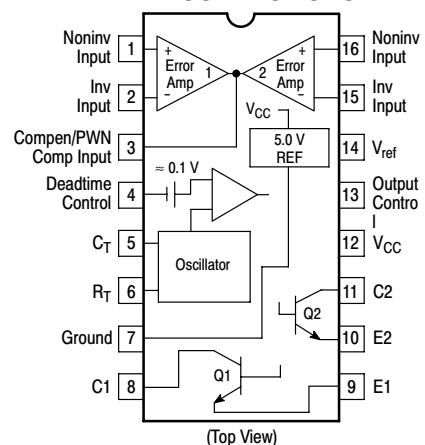

ORDERING INFORMATION

See detailed ordering and shipping information in the package dimensions section on page 4 of this data sheet.

TL494, NCV494

RECOMMENDED OPERATING CONDITIONS

| Characteristics | Symbol | Min | Typ | Max | Unit |
|--|------------------|--------|-------|----------------|------------|
| Power Supply Voltage | V_{CC} | 7.0 | 15 | 40 | V |
| Collector Output Voltage | V_{C1}, V_{C2} | – | 30 | 40 | V |
| Collector Output Current (Each transistor) | I_{C1}, I_{C2} | – | – | 200 | mA |
| Amplified Input Voltage | V_{in} | –0.3 | – | $V_{CC} - 2.0$ | V |
| Current Into Feedback Terminal | I_{fb} | – | – | 0.3 | mA |
| Reference Output Current | I_{ref} | – | – | 10 | mA |
| Timing Resistor | R_T | 1.8 | 30 | 500 | k Ω |
| Timing Capacitor | C_T | 0.0047 | 0.001 | 10 | μ F |
| Oscillator Frequency | f_{osc} | 1.0 | 40 | 200 | kHz |

ELECTRICAL CHARACTERISTICS ($V_{CC} = 15$ V, $C_T = 0.01$ μ F, $R_T = 12$ k Ω , unless otherwise noted.)

For typical values $T_A = 25^\circ\text{C}$, for min/max values T_A is the operating ambient temperature range that applies, unless otherwise noted.

| Characteristics | Symbol | Min | Typ | Max | Unit |
|-----------------|--------|-----|-----|-----|------|
|-----------------|--------|-----|-----|-----|------|

REFERENCE SECTION

| | | | | | |
|---|--------------|------|-----|------|----|
| Reference Voltage ($I_O = 1.0$ mA) | V_{ref} | 4.75 | 5.0 | 5.25 | V |
| Line Regulation ($V_{CC} = 7.0$ V to 40 V) | Reg_{line} | – | 2.0 | 25 | mV |
| Load Regulation ($I_O = 1.0$ mA to 10 mA) | Reg_{load} | – | 3.0 | 15 | mV |
| Short Circuit Output Current ($V_{ref} = 0$ V) | I_{SC} | 15 | 35 | 75 | mA |

OUTPUT SECTION

| | | | | | |
|---|------------------------------|--------|------------|------------|---------------|
| Collector Off–State Current ($V_{CC} = 40$ V, $V_{CE} = 40$ V) | $I_{C(off)}$ | – | 2.0 | 100 | μ A |
| Emitter Off–State Current $V_{CC} = 40$ V, $V_C = 40$ V, $V_E = 0$ V) | $I_{E(off)}$ | – | – | –100 | μ A |
| Collector–Emitter Saturation Voltage (Note 2) Common–Emitter ($V_E = 0$ V, $I_C = 200$ mA) Emitter–Follower ($V_C = 15$ V, $I_E = -200$ mA) | $V_{sat(C)}$ $V_{sat(E)}$ | – – | 1.1 1.5 | 1.3 2.5 | V |
| Output Control Pin Current Low State ($V_{OC} \leq 0.4$ V) High State ($V_{OC} = V_{ref}$) | I_{OCL} I_{OCH} | – – | 10 0.2 | – 3.5 | μ A mA |
| Output Voltage Rise Time Common–Emitter (See Figure 12) Emitter–Follower (See Figure 13) | t_r | – – | 100 100 | 200 200 | ns |
| Output Voltage Fall Time Common–Emitter (See Figure 12) Emitter–Follower (See Figure 13) | t_f | – – | 25 40 | 100 100 | ns |

- Low duty cycle pulse techniques are used during test to maintain junction temperature as close to ambient temperature as possible.

TL494, NCV494

ELECTRICAL CHARACTERISTICS ($V_{CC} = 15\text{ V}$, $C_T = 0.01\ \mu\text{F}$, $R_T = 12\ \text{k}\Omega$, unless otherwise noted.)

For typical values $T_A = 25^\circ\text{C}$, for min/max values T_A is the operating ambient temperature range that applies, unless otherwise noted.

| Characteristics | Symbol | Min | Typ | Max | Unit |
|-----------------|--------|-----|-----|-----|------|
|-----------------|--------|-----|-----|-----|------|

ERROR AMPLIFIER SECTION

| | | | | | |
|--|-----------|----------------------|------|------|---------------|
| Input Offset Voltage ($V_{O(Pin\ 3)} = 2.5\ \text{V}$) | V_{IO} | – | 2.0 | 10 | mV |
| Input Offset Current ($V_{O(Pin\ 3)} = 2.5\ \text{V}$) | I_{IO} | – | 5.0 | 250 | nA |
| Input Bias Current ($V_{O(Pin\ 3)} = 2.5\ \text{V}$) | I_{IB} | – | –0.1 | –1.0 | μA |
| Input Common Mode Voltage Range ($V_{CC} = 40\ \text{V}$, $T_A = 25^\circ\text{C}$) | V_{ICR} | –0.3 to $V_{CC}-2.0$ | | | V |
| Open Loop Voltage Gain ($\Delta V_{O} = 3.0\ \text{V}$, $V_{O} = 0.5\ \text{V}$ to $3.5\ \text{V}$, $R_L = 2.0\ \text{k}\Omega$) | A_{VOL} | 70 | 95 | – | dB |
| Unity-Gain Crossover Frequency ($V_{O} = 0.5\ \text{V}$ to $3.5\ \text{V}$, $R_L = 2.0\ \text{k}\Omega$) | f_{C-} | – | 350 | – | kHz |
| Phase Margin at Unity-Gain ($V_{O} = 0.5\ \text{V}$ to $3.5\ \text{V}$, $R_L = 2.0\ \text{k}\Omega$) | ϕ_m | – | 65 | – | deg. |
| Common Mode Rejection Ratio ($V_{CC} = 40\ \text{V}$) | CMRR | 65 | 90 | – | dB |
| Power Supply Rejection Ratio ($\Delta V_{CC} = 33\ \text{V}$, $V_{O} = 2.5\ \text{V}$, $R_L = 2.0\ \text{k}\Omega$) | PSRR | – | 100 | – | dB |
| Output Sink Current ($V_{O(Pin\ 3)} = 0.7\ \text{V}$) | I_{O-} | 0.3 | 0.7 | – | mA |
| Output Source Current ($V_{O(Pin\ 3)} = 3.5\ \text{V}$) | I_{O+} | 2.0 | –4.0 | – | mA |

PWM COMPARATOR SECTION (Test Circuit Figure 11)

| | | | | | |
|---|----------|-----|-----|-----|----|
| Input Threshold Voltage (Zero Duty Cycle) | V_{TH} | – | 2.5 | 4.5 | V |
| Input Sink Current ($V_{(Pin\ 3)} = 0.7\ \text{V}$) | I_{I-} | 0.3 | 0.7 | – | mA |

DEADTIME CONTROL SECTION (Test Circuit Figure 11)

| | | | | | |
|--|--------------|---------|----------|----------|---------------|
| Input Bias Current (Pin 4) ($V_{Pin\ 4} = 0\ \text{V}$ to $5.25\ \text{V}$) | $I_{IB(DT)}$ | – | –2.0 | –10 | μA |
| Maximum Duty Cycle, Each Output, Push-Pull Mode ($V_{Pin\ 4} = 0\ \text{V}$, $C_T = 0.01\ \mu\text{F}$, $R_T = 12\ \text{k}\Omega$) ($V_{Pin\ 4} = 0\ \text{V}$, $C_T = 0.001\ \mu\text{F}$, $R_T = 30\ \text{k}\Omega$) | DC_{max} | 45 – | 48 45 | 50 50 | % |
| Input Threshold Voltage (Pin 4) (Zero Duty Cycle) (Maximum Duty Cycle) | V_{th} | – 0 | 2.8 – | 3.3 – | V |

OSCILLATOR SECTION

| | | | | | |
|--|----------------------------|---|-----|----|-----|
| Frequency ($C_T = 0.001\ \mu\text{F}$, $R_T = 30\ \text{k}\Omega$) | f_{osc} | – | 40 | – | kHz |
| Standard Deviation of Frequency* ($C_T = 0.001\ \mu\text{F}$, $R_T = 30\ \text{k}\Omega$) | $\sigma_{f_{osc}}$ | – | 3.0 | – | % |
| Frequency Change with Voltage ($V_{CC} = 7.0\ \text{V}$ to $40\ \text{V}$, $T_A = 25^\circ\text{C}$) | $\Delta f_{osc}(\Delta V)$ | – | 0.1 | – | % |
| Frequency Change with Temperature ($\Delta T_A = T_{low}$ to T_{high}) ($C_T = 0.01\ \mu\text{F}$, $R_T = 12\ \text{k}\Omega$) | $\Delta f_{osc}(\Delta T)$ | – | – | 12 | % |

UNDERVOLTAGE LOCKOUT SECTION

| | | | | | |
|---|----------|-----|------|-----|---|
| Turn-On Threshold (V_{CC} increasing, $I_{ref} = 1.0\ \text{mA}$) | V_{th} | 5.5 | 6.43 | 7.0 | V |
|---|----------|-----|------|-----|---|

TOTAL DEVICE

| | | | | | |
|--|----------|--------|------------|----------|----|
| Standby Supply Current (Pin 6 at V_{ref} , All other inputs and outputs open) ($V_{CC} = 15\ \text{V}$) ($V_{CC} = 40\ \text{V}$) | I_{CC} | – – | 5.5 7.0 | 10 15 | mA |
| Average Supply Current ($C_T = 0.01\ \mu\text{F}$, $R_T = 12\ \text{k}\Omega$, $V_{(Pin\ 4)} = 2.0\ \text{V}$) ($V_{CC} = 15\ \text{V}$) (See Figure 12) | | – | 7.0 | – | mA |

* Standard deviation is a measure of the statistical distribution about the mean as derived from the formula, $\sigma = \sqrt{\frac{\sum_{n=1}^N (X_n - \bar{X})^2}{N - 1}}$

TL494, NCV494

ORDERING INFORMATION

| Device | Package | Shipping† |
|--------------|----------------------|------------------|
| TL494BD | SOIC-16 | 48 Units / Rail |
| TL494BDG | SOIC-16 (Pb-Free) | 48 Units / Rail |
| TL494BDR2 | SOIC-16 | 2500 Tape & Reel |
| TL494BDR2G | SOIC-16 (Pb-Free) | 2500 Tape & Reel |
| TL494CD | SOIC-16 | 48 Units / Rail |
| TL494CDG | SOIC-16 (Pb-Free) | 48 Units / Rail |
| TL494CDR2 | SOIC-16 | 2500 Tape & Reel |
| TL494CDR2G | SOIC-16 (Pb-Free) | 2500 Tape & Reel |
| TL494CN | PDIP-16 | 25 Units / Rail |
| TL494CNG | PDIP-16 (Pb-Free) | 25 Units / Rail |
| TL494IN | PDIP-16 | 25 Units / Rail |
| TL494ING | PDIP-16 (Pb-Free) | 25 Units / Rail |
| NCV494BDR2* | SOIC-16 | 2500 Tape & Reel |
| NCV494BDR2G* | SOIC-16 (Pb-Free) | 2500 Tape & Reel |

†For information on tape and reel specifications, including part orientation and tape sizes, please refer to our Tape and Reel Packaging Specifications Brochure, BRD8011/D.

*NCV494: $T_{low} = -40^{\circ}\text{C}$, $T_{high} = +125^{\circ}\text{C}$. Guaranteed by design. NCV prefix is for automotive and other applications requiring site and change control.

TL494, NCV494

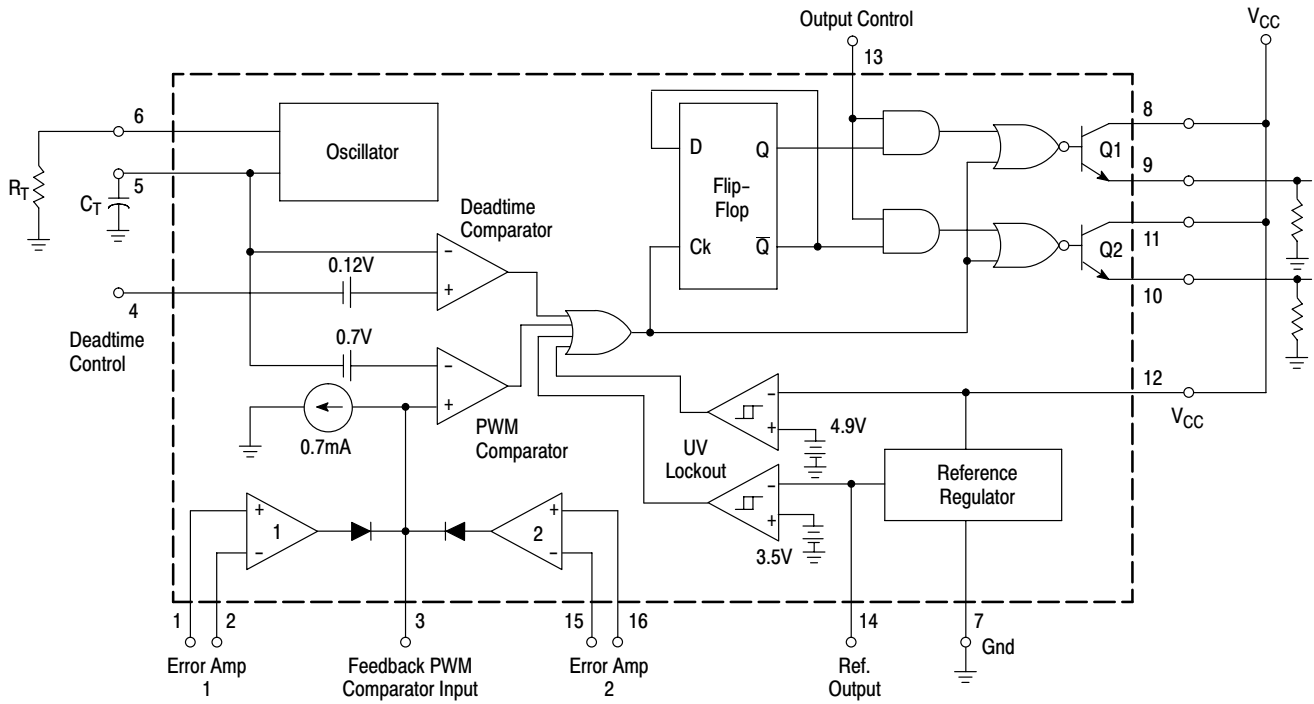

This device contains 46 active transistors.

Figure 1. Representative Block Diagram

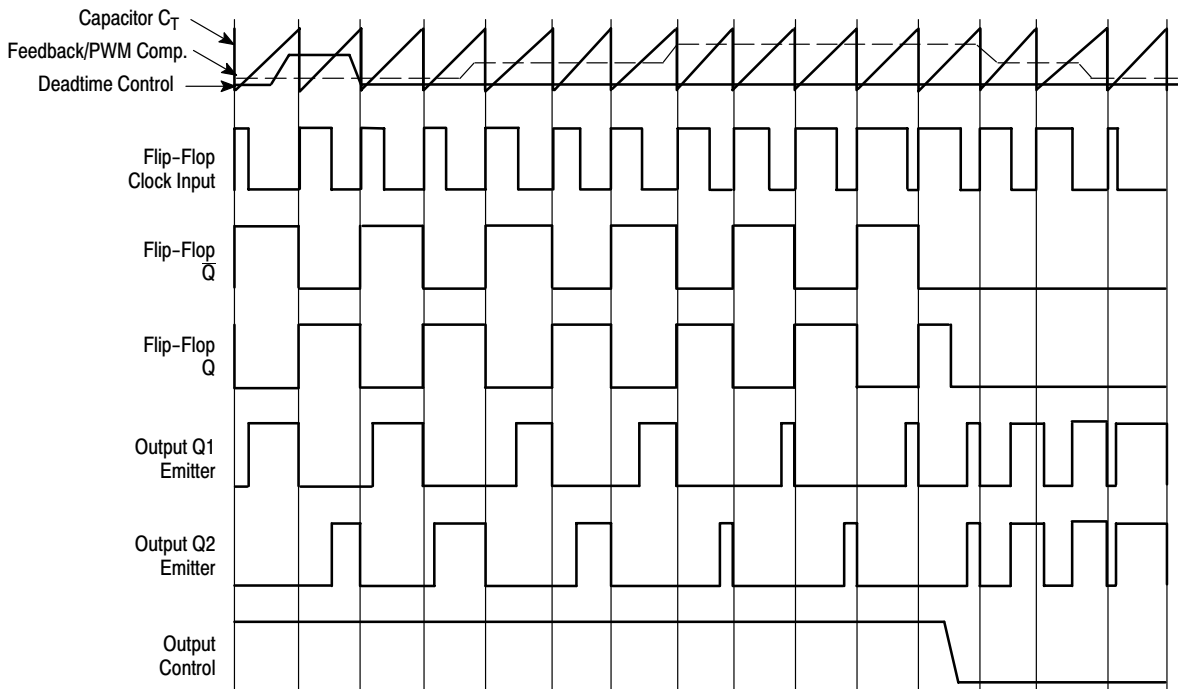

Figure 2. Timing Diagram

APPLICATIONS INFORMATION

Description

The TL494 is a fixed-frequency pulse width modulation control circuit, incorporating the primary building blocks required for the control of a switching power supply. (See Figure 1.) An internal-linear sawtooth oscillator is frequency-programmable by two external components, R_T and C_T . The approximate oscillator frequency is determined by:

$$f_{osc} \approx \frac{1.1}{R_T \cdot C_T}$$

For more information refer to Figure 3.

Output pulse width modulation is accomplished by comparison of the positive sawtooth waveform across capacitor C_T to either of two control signals. The NOR gates, which drive output transistors Q1 and Q2, are enabled only when the flip-flop clock-input line is in its low state. This happens only during that portion of time when the sawtooth voltage is greater than the control signals. Therefore, an increase in control-signal amplitude causes a corresponding linear decrease of output pulse width. (Refer to the Timing Diagram shown in Figure 2.)

The control signals are external inputs that can be fed into the deadtime control, the error amplifier inputs, or the feedback input. The deadtime control comparator has an effective 120 mV input offset which limits the minimum output deadtime to approximately the first 4% of the sawtooth-cycle time. This would result in a maximum duty cycle on a given output of 96% with the output control grounded, and 48% with it connected to the reference line. Additional deadtime may be imposed on the output by setting the deadtime-control input to a fixed voltage, ranging between 0 V to 3.3 V.

Functional Table

| Input/Output Controls | Output Function | $\frac{f_{out}}{f_{osc}} =$ |
|-----------------------|------------------------------|-----------------------------|
| Grounded | Single-ended PWM @ Q1 and Q2 | 1.0 |
| @ V_{ref} | Push-pull Operation | 0.5 |

The pulse width modulator comparator provides a means for the error amplifiers to adjust the output pulse width from the maximum percent on-time, established by the deadtime control input, down to zero, as the voltage at the feedback pin varies from 0.5 V to 3.5 V. Both error amplifiers have a

common mode input range from -0.3 V to ($V_{CC} - 2V$), and may be used to sense power-supply output voltage and current. The error-amplifier outputs are active high and are ORed together at the noninverting input of the pulse-width modulator comparator. With this configuration, the amplifier that demands minimum output on time, dominates control of the loop.

When capacitor C_T is discharged, a positive pulse is generated on the output of the deadtime comparator, which clocks the pulse-steering flip-flop and inhibits the output transistors, Q1 and Q2. With the output-control connected to the reference line, the pulse-steering flip-flop directs the modulated pulses to each of the two output transistors alternately for push-pull operation. The output frequency is equal to half that of the oscillator. Output drive can also be taken from Q1 or Q2, when single-ended operation with a maximum on-time of less than 50% is required. This is desirable when the output transformer has a ringback winding with a catch diode used for snubbing. When higher output-drive currents are required for single-ended operation, Q1 and Q2 may be connected in parallel, and the output-mode pin must be tied to ground to disable the flip-flop. The output frequency will now be equal to that of the oscillator.

The TL494 has an internal 5.0 V reference capable of sourcing up to 10 mA of load current for external bias circuits. The reference has an internal accuracy of $\pm 5.0\%$ with a typical thermal drift of less than 50 mV over an operating temperature range of 0° to 70°C.

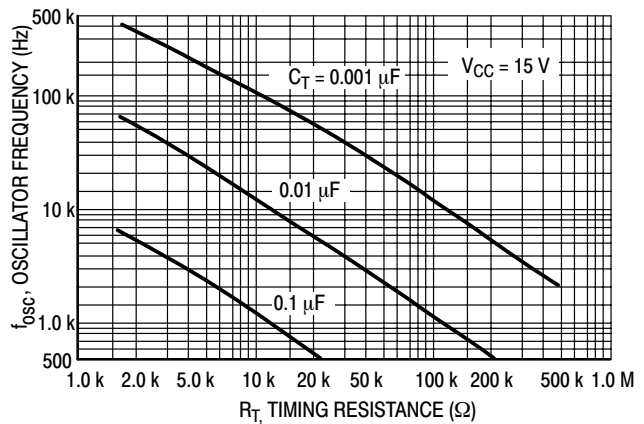

Figure 3. Oscillator Frequency versus Timing Resistance

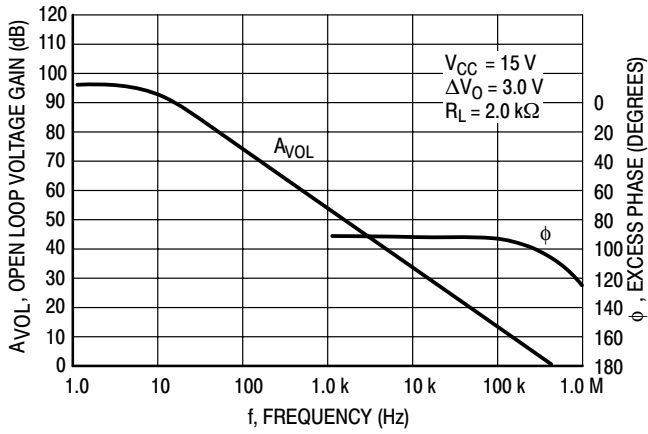

Figure 4. Open Loop Voltage Gain and Phase versus Frequency

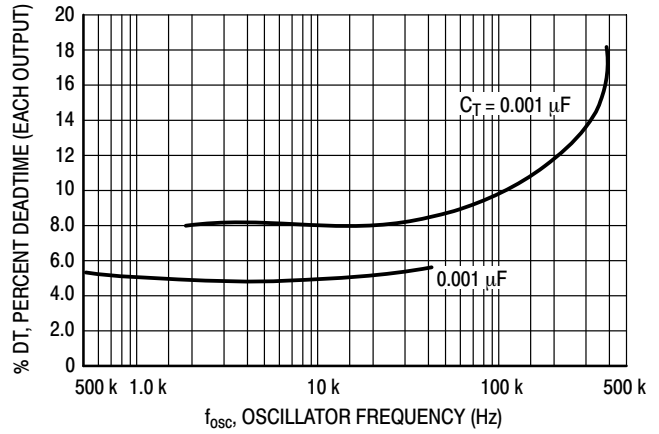

Figure 5. Percent Deadtime versus Oscillator Frequency

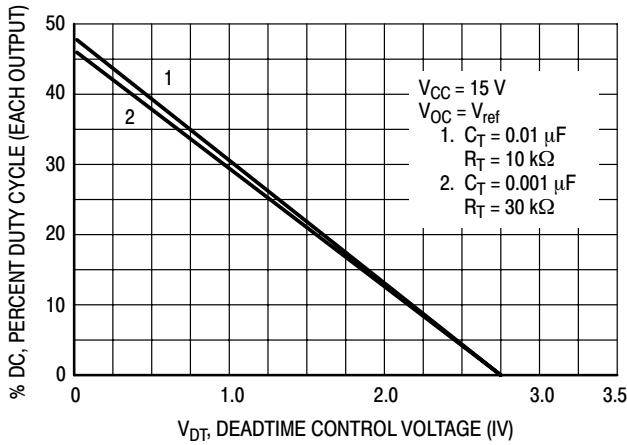

Figure 6. Percent Duty Cycle versus Deadtime Control Voltage

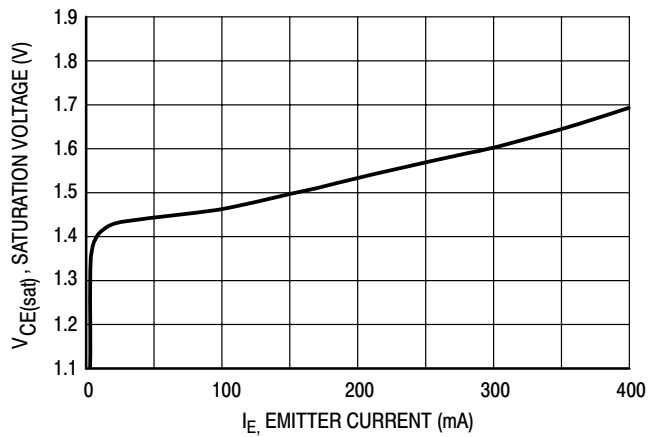

Figure 7. Emitter-Follower Configuration Output Saturation Voltage versus Emitter Current

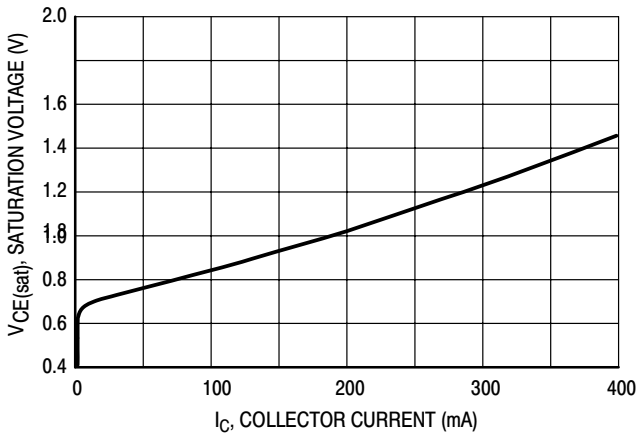

Figure 8. Common-Emitter Configuration Output Saturation Voltage versus Collector Current

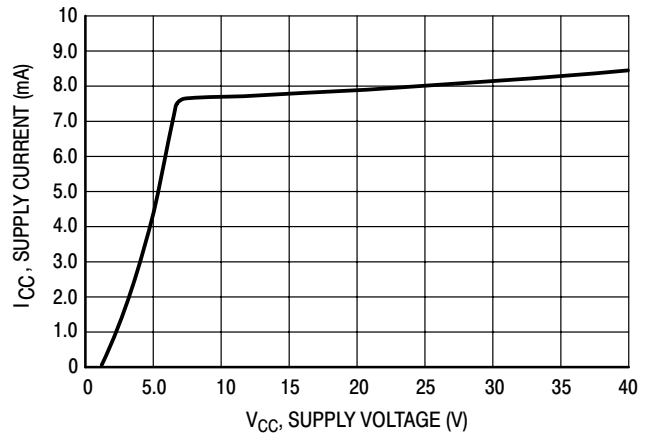

Figure 9. Standby Supply Current versus Supply Voltage

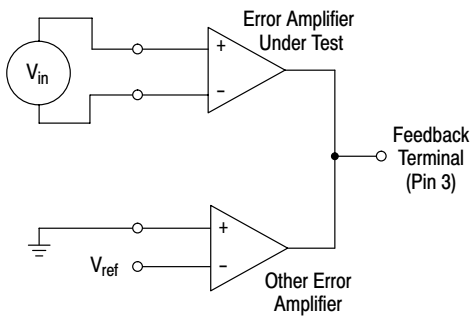

Figure 10. Error-Amplifier Characteristics

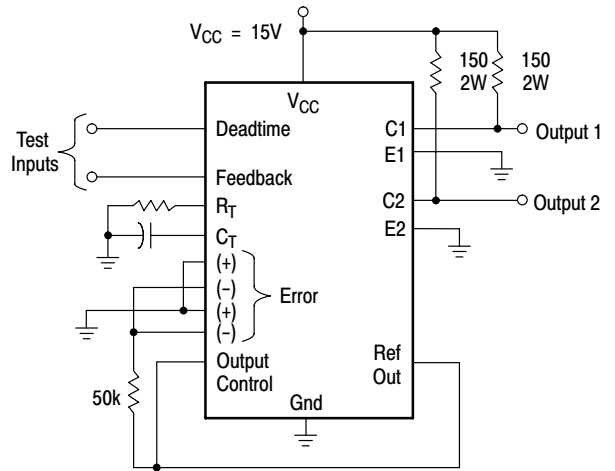

Figure 11. Deadtime and Feedback Control Circuit

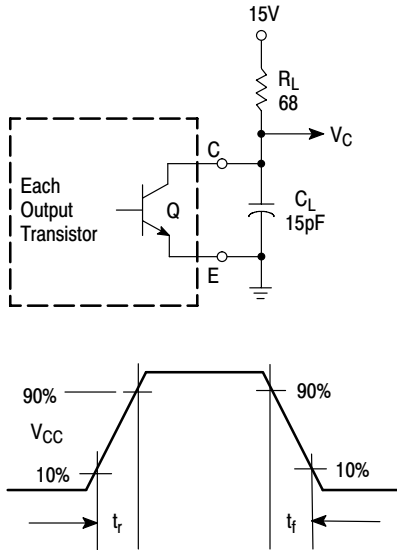

Figure 12. Common-Emitter Configuration Test Circuit and Waveform

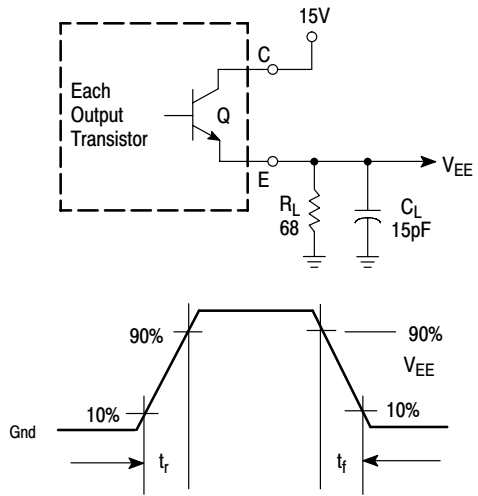

Figure 13. Emitter-Follower Configuration Test Circuit and Waveform

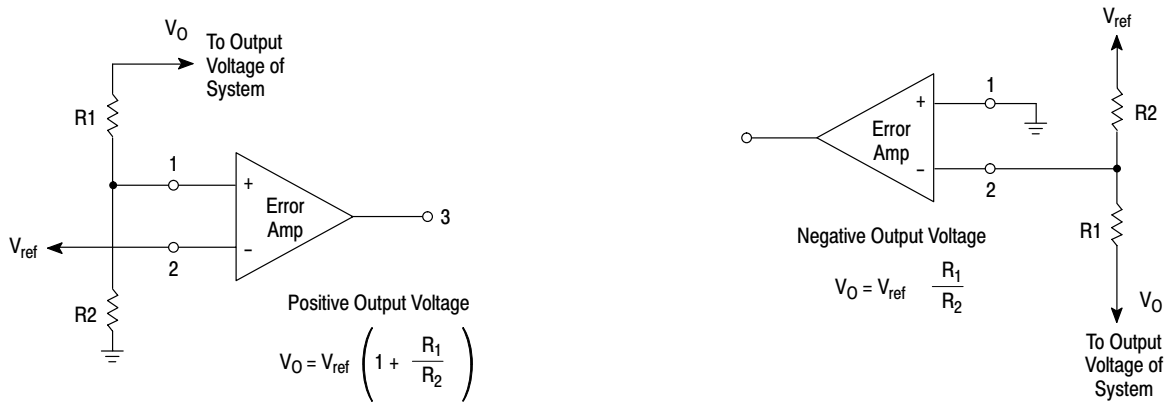
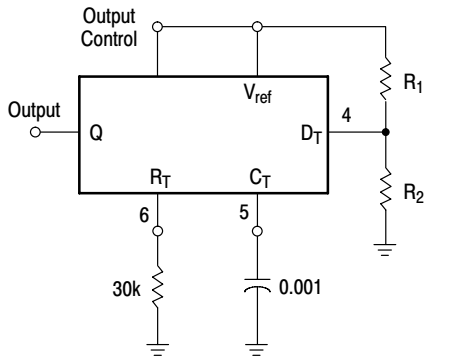

Figure 14. Error-Amplifier Sensing Techniques



$$\text{Max. \% on Time, each output} \approx 45 - \left(\frac{80}{1 + \frac{R_1}{R_2}} \right)$$

Figure 15. Deadtime Control Circuit

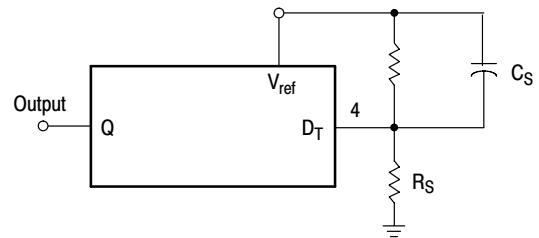

Figure 16. Soft-Start Circuit

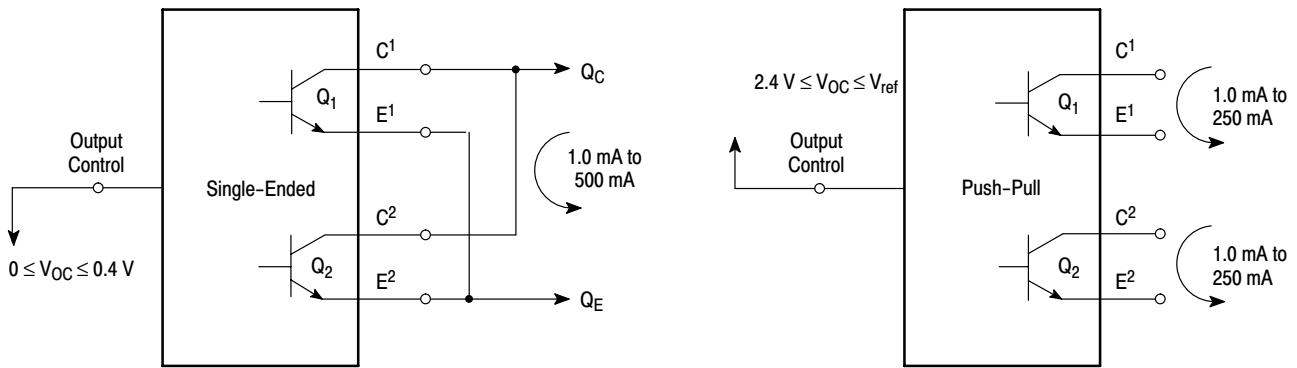

Figure 17. Output Connections for Single-Ended and Push-Pull Configurations

TL494, NCV494

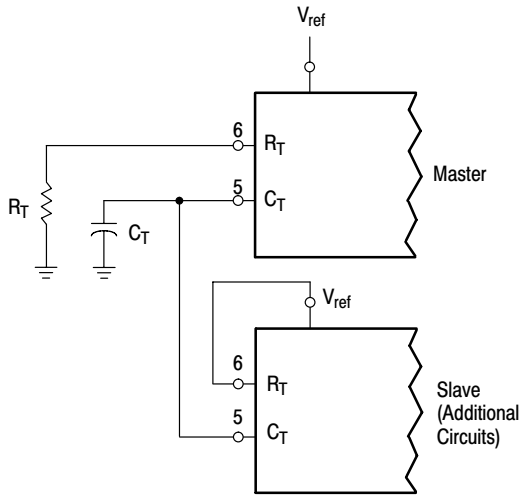

Figure 18. Slaving Two or More Control Circuits

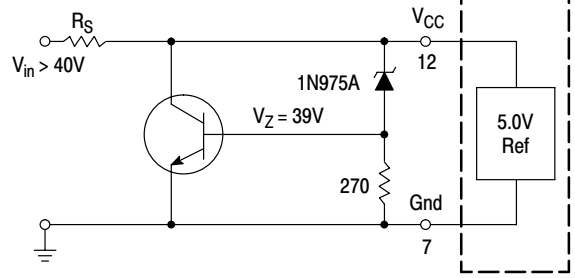

Figure 19. Operation with $V_{in} > 40\text{ V}$ Using External Zener

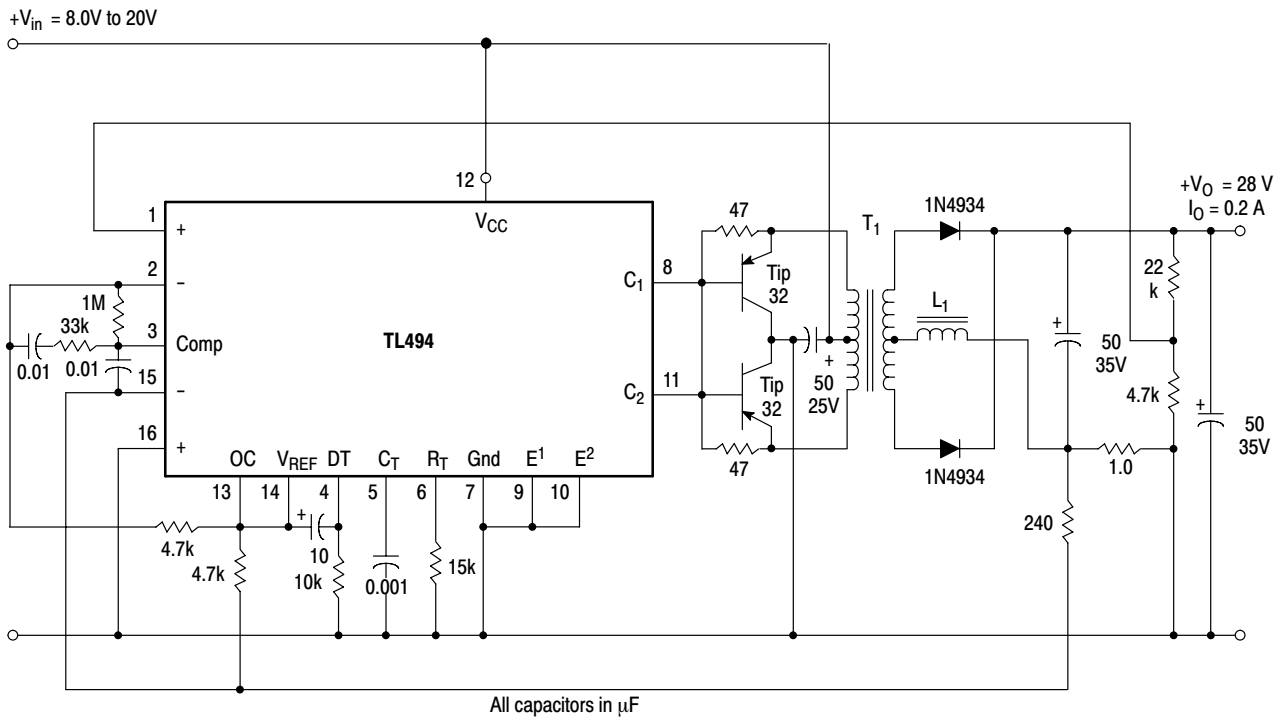

Figure 20. Pulse Width Modulated Push-Pull Converter

| Test | Conditions | Results |
|-----------------------|--|-------------------|
| Line Regulation | $V_{in} = 10\text{ V to } 40\text{ V}$ | 14 mV 0.28% |
| Load Regulation | $V_{in} = 28\text{ V}, I_O = 1.0\text{ mA to } 1.0\text{ A}$ | 3.0 mV 0.06% |
| Output Ripple | $V_{in} = 28\text{ V}, I_O = 1.0\text{ A}$ | 65 mV pp P.A.R.D. |
| Short Circuit Current | $V_{in} = 28\text{ V}, R_L = 0.1\ \Omega$ | 1.6 A |
| Efficiency | $V_{in} = 28\text{ V}, I_O = 1.0\text{ A}$ | 71% |

L1 - 3.5 mH @ 0.3 A
 T1 - Primary: 20T C.T. #28 AWG
 Secondary: 120T C.T. #36 AWG
 Core: Ferroxcube 1408P-L00-3CB

TL494, NCV494

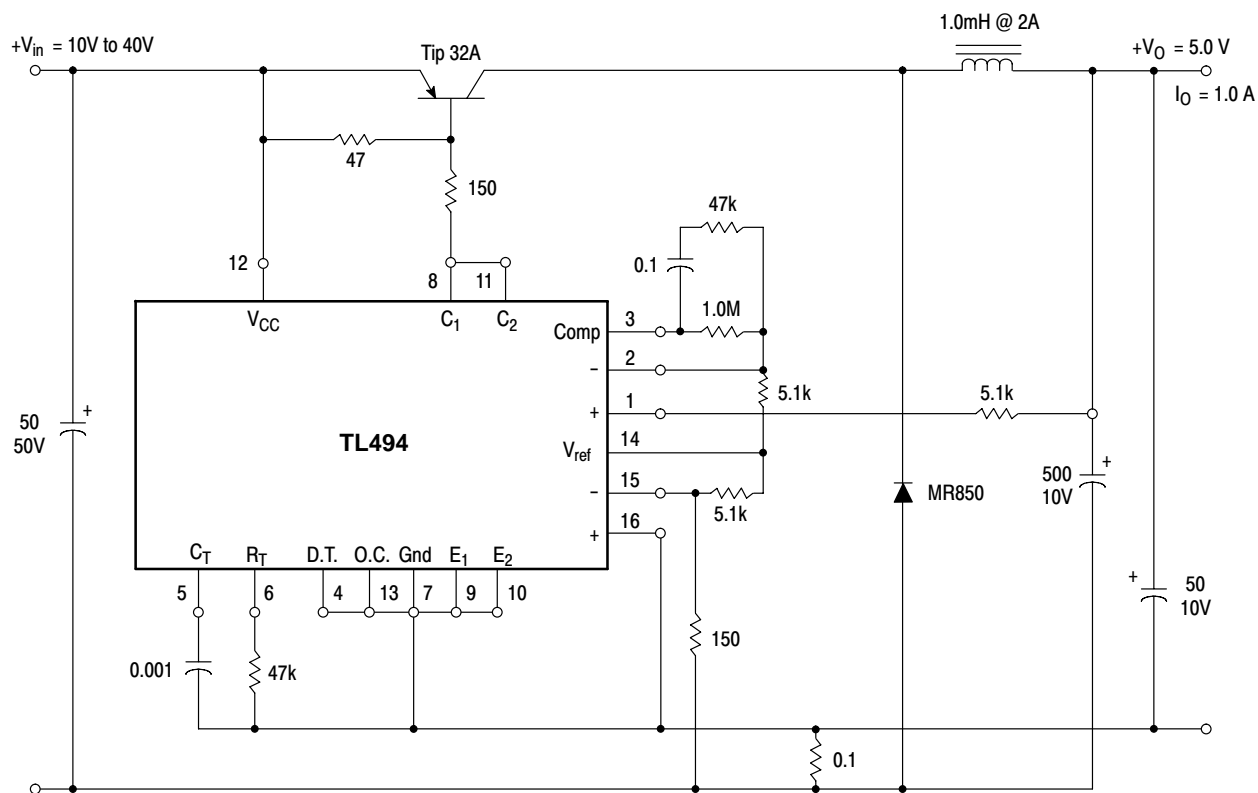

Figure 21. Pulse Width Modulated Step-Down Converter

| Test | Conditions | Results |
|-----------------------|--|-------------------|
| Line Regulation | $V_{in} = 8.0 \text{ V to } 40 \text{ V}$ | 3.0 mV 0.01% |
| Load Regulation | $V_{in} = 12.6 \text{ V}, I_O = 0.2 \text{ mA to } 200 \text{ mA}$ | 5.0 mV 0.02% |
| Output Ripple | $V_{in} = 12.6 \text{ V}, I_O = 200 \text{ mA}$ | 40 mV pp P.A.R.D. |
| Short Circuit Current | $V_{in} = 12.6 \text{ V}, R_L = 0.1 \Omega$ | 250 mA |
| Efficiency | $V_{in} = 12.6 \text{ V}, I_O = 200 \text{ mA}$ | 72% |

TL494, NCV494

PACKAGE DIMENSIONS

SOIC-16
D SUFFIX
CASE 751B-05
ISSUE J

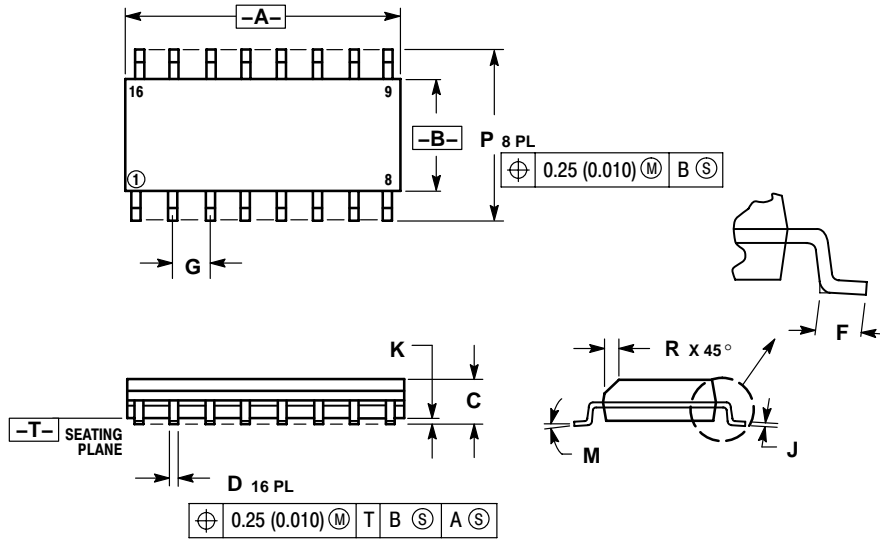

NOTES:

1. DIMENSIONING AND TOLERANCING PER ANSI Y14.5M, 1982.
2. CONTROLLING DIMENSION: MILLIMETER.
3. DIMENSIONS A AND B DO NOT INCLUDE MOLD PROTRUSION.
4. MAXIMUM MOLD PROTRUSION 0.15 (0.006) PER SIDE.
5. DIMENSION D DOES NOT INCLUDE DAMBAR PROTRUSION. ALLOWABLE DAMBAR PROTRUSION SHALL BE 0.127 (0.005) TOTAL IN EXCESS OF THE D DIMENSION AT MAXIMUM MATERIAL CONDITION.

| DIM | MILLIMETERS | | INCHES | |
|-----|-------------|-------|-----------|-------|
| | MIN | MAX | MIN | MAX |
| A | 9.80 | 10.00 | 0.386 | 0.393 |
| B | 3.80 | 4.00 | 0.150 | 0.157 |
| C | 1.35 | 1.75 | 0.054 | 0.068 |
| D | 0.35 | 0.49 | 0.014 | 0.019 |
| F | 0.40 | 1.25 | 0.016 | 0.049 |
| G | 1.27 BSC | | 0.050 BSC | |
| J | 0.19 | 0.25 | 0.008 | 0.009 |
| K | 0.10 | 0.25 | 0.004 | 0.009 |
| M | 0° | 7° | 0° | 7° |
| P | 5.80 | 6.20 | 0.229 | 0.244 |
| R | 0.25 | 0.50 | 0.010 | 0.019 |

TL494, NCV494

PACKAGE DIMENSIONS

PDIP-16
N SUFFIX
CASE 648-08
ISSUE T

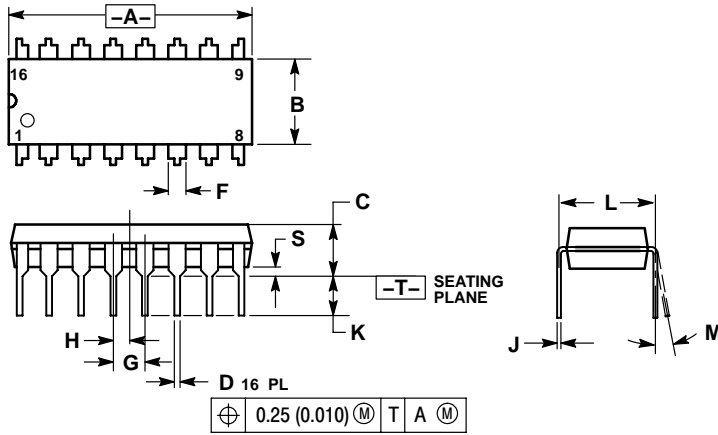

NOTES:

1. DIMENSIONING AND TOLERANCING PER ANSI Y14.5M, 1982.
2. CONTROLLING DIMENSION: INCH.
3. DIMENSION L TO CENTER OF LEADS WHEN FORMED PARALLEL.
4. DIMENSION B DOES NOT INCLUDE MOLD FLASH.
5. ROUNDED CORNERS OPTIONAL.

| DIM | INCHES | | MILLIMETERS | |
|-----|-----------|-------|-------------|-------|
| | MIN | MAX | MIN | MAX |
| A | 0.740 | 0.770 | 18.80 | 19.55 |
| B | 0.250 | 0.270 | 6.35 | 6.85 |
| C | 0.145 | 0.175 | 3.69 | 4.44 |
| D | 0.015 | 0.021 | 0.39 | 0.53 |
| F | 0.040 | 0.70 | 1.02 | 1.77 |
| G | 0.100 BSC | | 2.54 BSC | |
| H | 0.050 BSC | | 1.27 BSC | |
| J | 0.008 | 0.015 | 0.21 | 0.38 |
| K | 0.110 | 0.130 | 2.80 | 3.30 |
| L | 0.295 | 0.305 | 7.50 | 7.74 |
| M | 0° | 10° | 0° | 10° |
| S | 0.020 | 0.040 | 0.51 | 1.01 |

TL494, NCV494

SWITCHMODE is a trademark of Semiconductor Components Industries, LLC.

ON Semiconductor and  are registered trademarks of Semiconductor Components Industries, LLC (SCILLC). SCILLC reserves the right to make changes without further notice to any products herein. SCILLC makes no warranty, representation or guarantee regarding the suitability of its products for any particular purpose, nor does SCILLC assume any liability arising out of the application or use of any product or circuit, and specifically disclaims any and all liability, including without limitation special, consequential or incidental damages. "Typical" parameters which may be provided in SCILLC data sheets and/or specifications can and do vary in different applications and actual performance may vary over time. All operating parameters, including "Typicals" must be validated for each customer application by customer's technical experts. SCILLC does not convey any license under its patent rights nor the rights of others. SCILLC products are not designed, intended, or authorized for use as components in systems intended for surgical implant into the body, or other applications intended to support or sustain life, or for any other application in which the failure of the SCILLC product could create a situation where personal injury or death may occur. Should Buyer purchase or use SCILLC products for any such unintended or unauthorized application, Buyer shall indemnify and hold SCILLC and its officers, employees, subsidiaries, affiliates, and distributors harmless against all claims, costs, damages, and expenses, and reasonable attorney fees arising out of, directly or indirectly, any claim of personal injury or death associated with such unintended or unauthorized use, even if such claim alleges that SCILLC was negligent regarding the design or manufacture of the part. SCILLC is an Equal Opportunity/Affirmative Action Employer. This literature is subject to all applicable copyright laws and is not for resale in any manner.

PUBLICATION ORDERING INFORMATION

LITERATURE FULFILLMENT:

Literature Distribution Center for ON Semiconductor
P.O. Box 61312, Phoenix, Arizona 85082-1312 USA
Phone: 480-829-7710 or 800-344-3860 Toll Free USA/Canada
Fax: 480-829-7709 or 800-344-3867 Toll Free USA/Canada
Email: orderlit@onsemi.com

N. American Technical Support: 800-282-9855 Toll Free
USA/Canada

Japan: ON Semiconductor, Japan Customer Focus Center
2-9-1 Kamimeguro, Meguro-ku, Tokyo, Japan 153-0051
Phone: 81-3-5773-3850

ON Semiconductor Website: <http://onsemi.com>

Order Literature: <http://www.onsemi.com/litorder>

For additional information, please contact your
local Sales Representative.