

# NCP1015

## Self-Supplied Monolithic Switcher for Low Standby-Power Offline SMPS

The NCP1015 integrates a fixed-frequency current-mode controller and a 700 V voltage MOSFET. Housed in a PDIP-7 or SOT-223 package, the NCP1015 offers everything needed to build a rugged and low-cost power supply, including soft-start, frequency jittering, short-circuit protection, skip-cycle, a maximum peak current set-point and a Dynamic Self-Supply (no need for an auxiliary winding).

Unlike other monolithic solutions, the NCP1015 is quiet by nature: during nominal load operation, the part switches at one of the available frequencies (65–100 kHz). When the current set-point falls below a given value, e.g. the output power demand diminishes, the IC automatically enters the so-called skip cycle mode and provides excellent efficiency at light loads. Because this occurs at typically 0.25 of the maximum peak value, no acoustic noise takes place. As a result, standby power is reduced to the minimum without acoustic noise generation.

Short-circuit detection takes place when the feedback signal fades away e.g. un-true short-circuit or is broken optocoupler cases. Finally soft-start and frequency jittering further ease the designer task to quickly develop low-cost and robust offline power supplies.

For improved standby performance, the connection of an auxiliary winding stops the DSS operation and helps to consume less than 100 mW at high line.

### Features

- Built-in 700 V MOSFET with typical  $R_{DS(on)}$  of 11  $\Omega$
- Large Creepage Distance between High-voltage Pins
- Current-mode Fixed Frequency Operation: 65 kHz – 100 kHz
- Skip-cycle Operation at Low Peak Currents Only: No Acoustic Noise!
- Dynamic Self-Supply, No Need for an Auxiliary Winding
- Internal 1 ms Soft-start
- Auto-recovery Internal Output Short-circuit Protection
- Frequency Jittering for Better EMI Signature
- Below 100 mW Standby Power if Auxiliary Winding is Used
- Internal Temperature Shutdown
- Direct Optocoupler Connection
- SPICE Models Available for TRANsient and AC Analysis
- This is a Pb-Free Device

### Typical Applications

- Low Power ac-dc Adapters for Chargers
- Auxiliary Power Supplies (USB, Appliances, TVs, etc.)



ON Semiconductor®

<http://onsemi.com>

### MARKING DIAGRAMS

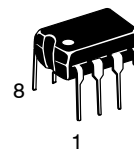

PDIP-7  
CASE 626A  
AP SUFFIX

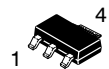
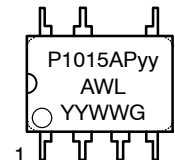

SOT-223  
CASE 318E  
ST SUFFIX

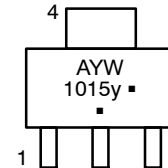

yy = 06 (65 kHz), 10 (100 kHz)  
y = A (65 kHz), B (100 kHz)  
A = Assembly Location  
WL = Wafer Lot  
YY = Year  
WW = Work Week  
G or ■ = Pb-Free Package

(\*Note: Microdot may be in either location)

### PIN CONNECTIONS

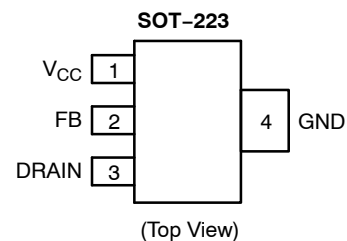
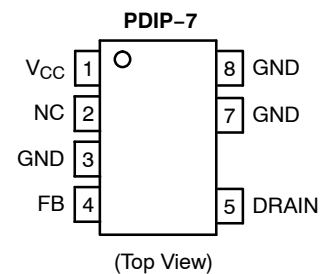

### ORDERING INFORMATION

See detailed ordering and shipping information in the package dimensions section on page 20 of this data sheet.

# NCP1015

## Indicative Maximum Output Power from NCP1015

$R_{DS(on)} - I_p$	230 Vac	100 – 250 Vac
11 $\Omega$ – 450 mA DSS	14 W	6.0 W
11 $\Omega$ – 450 mA Auxiliary Winding	19 W	8.0 W

1. Informative values only, with:  $T_{amb} = 50^\circ\text{C}$ , circuit mounted on minimum copper area as recommended.

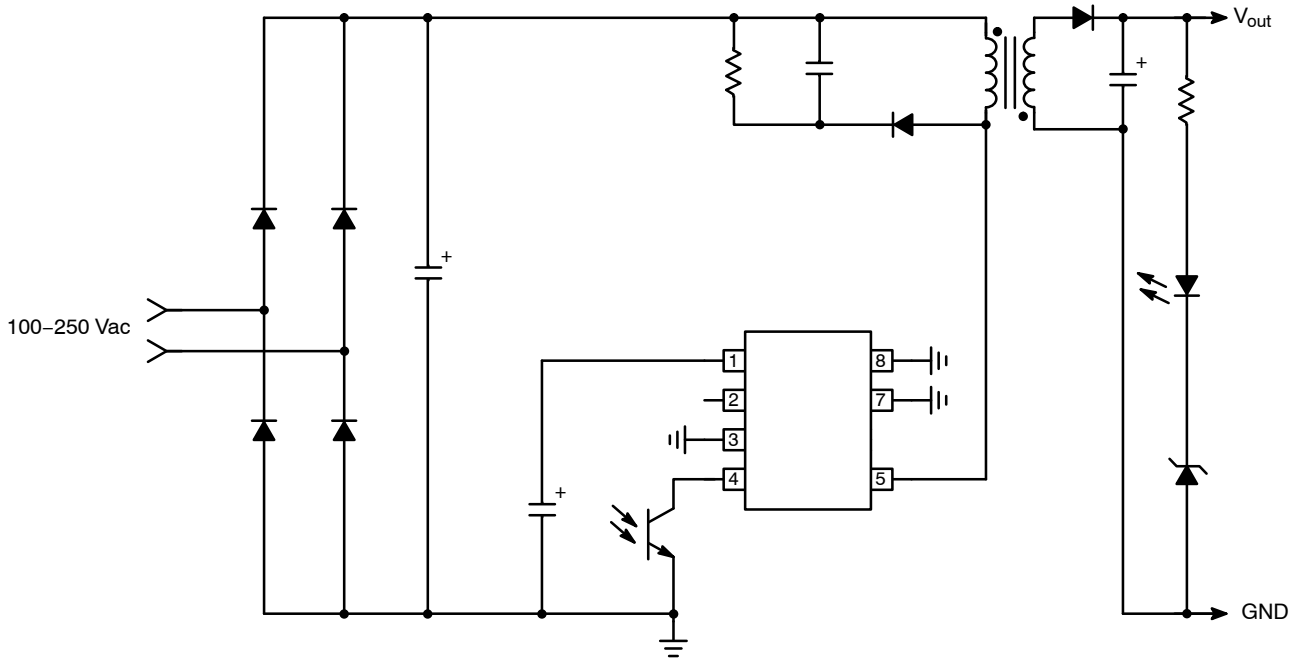

Figure 1. Typical Application Example

## PIN FUNCTION DESCRIPTION

Pin No.		Pin Name	Function	Description
SOT-223	PDIP-7			
1	1	$V_{CC}$	Powers the Internal Circuitry	This pin is connected to an external capacitor of typically 10 $\mu\text{F}$ . The natural ripple superimposed on the $V_{CC}$ participates to the frequency jittering. For improved standby performance, an auxiliary $V_{CC}$ can be connected to Pin 1. The $V_{CC}$ also includes an active shunt which serves as an opto fail-safe protection.
-	2	NC	-	-
-	3	GND	The IC Ground	-
2	4	FB	Feedback Signal Input	By connecting an optocoupler to this pin, the peak current setpoint is adjusted accordingly to the output power demand.
3	5	DRAIN	Drain Connection	The internal drain MOSFET connection.
-	-	-	-	-
-	7	GND	The IC Ground	-
4	8	GND	The IC Ground	-



# NCP1015

**ELECTRICAL CHARACTERISTICS** (For typical values  $T_J=25^{\circ}\text{C}$ , for min/max values  $T_J=-40^{\circ}\text{C}$  to  $125^{\circ}\text{C}$ ,  $V_{CC}=8\text{V}$  unless otherwise noted)

Symbol	Rating	Pin	Min	Typ	Max	Unit
--------	--------	-----	-----	-----	-----	------

## SUPPLY SECTION AND $V_{CC}$ MANAGEMENT

$V_{CC(\text{off})}$	$V_{CC}$ increasing level at which the current source turns-off	1	7.9	8.5	9.1	V
$V_{CC(\text{on})}$	$V_{CC}$ decreasing level at which the current source turns-on	1	6.9	7.5	8.1	V
$V_{CC\text{LATCH}}$	Decreasing level at which the Latch-off phase Ends	1	4.4	4.7	5.1	V
$\Delta V_{CC}$	Hysteresis between $V_{CC(\text{off})}$	1	-	1.0	-	
ICC1	Internal IC consumption, MOSFET switching at 65 kHz	1	-	0.92	1.1	mA
ICC1	Internal IC consumption, MOSFET switching at 100 kHz	1	-	0.95	1.15	mA
$V_{\text{clamp}}$	Active zener voltage positive offset to $V_{CC(\text{off})}$	1	140	200	300	mV

## POWER SWITCH CIRCUIT

$R_{DS(\text{on})}$	Power Switch Circuit on-state resistance ( $I_d = 50\text{ mA}$ ) $T_J = 25^{\circ}\text{C}$ $T_J = 125^{\circ}\text{C}$	5 5	- -	11 -	19 24	$\Omega$
$V_{\text{dsb}}$	Power Switch Circuit & Startup breakdown voltage ( $I_{DS(\text{off})} = 100\ \mu\text{A}$ , $T_J = 25^{\circ}\text{C}$ )	5	700	-	-	V
$I_{DS(\text{off})}$	Power Switch & Startup breakdown voltage off-state leakage current $T_J = -40^{\circ}\text{C}$ ( $V_{\text{ds}} = 650\text{ V}$ ) $T_J = 25^{\circ}\text{C}$ ( $V_{\text{ds}} = 700\text{ V}$ ) $T_J = 125^{\circ}\text{C}$ ( $V_{\text{ds}} = 700\text{ V}$ )	5 5 5	- - -	70 50 30	120 - -	$\mu\text{A}$
$t_{\text{on}}$ $t_{\text{off}}$	Switching characteristics ( $R_L = 50\ \Omega$ , $V_{\text{ds}}$ set for $I_{\text{ds}} = 0.7 \times I_{\text{ds}(\text{lim})}$ ) Turn-on time (90% - 10%) Turn-off time (10% - 90%)	5 5	- -	20 10	- -	ns

## INTERNAL START-UP CURRENT SOURCE

IC1	High-voltage current source, $V_{CC} = 8\text{ V}$ $0^{\circ}\text{C} < T_J < 125^{\circ}\text{C}$ $-40^{\circ}\text{C} < T_J < 125^{\circ}\text{C}$	1	5.0 5.0	8.0 8.0	10 11	mA
IC2	High-voltage current source, $V_{CC} = 0$	1	-	10	-	mA

## CURRENT COMPARATOR $T_J = 25^{\circ}\text{C}$ (Note 2)

$I_{\text{peak}}$	Maximum internal current set-point	5	405	450	495	mA
$I_{\text{Lskip}}$	Default internal current set-point for skip cycle operation, percentage $I_{\text{peak,max}}$	-	-	25	-	%
$t_{\text{DEL}}$	Propagation delay from current detection to drain OFF state	-	-	125	-	ns
$t_{\text{LEB}}$	Leading Edge Blanking Duration	-	-	250	-	ns

## INTERNAL OSCILLATOR

$f_{\text{OSC}}$	Oscillation frequency, 65 kHz version, $T_J = 25^{\circ}\text{C}$ (Note 2)		59	65	71	kHz
$f_{\text{OSC}}$	Oscillation frequency, 100 kHz version, $T_J = 25^{\circ}\text{C}$ (Note 2)		90	100	110	kHz
$f_{\text{dither}}$	Frequency dithering compared to switching frequency (with active DSS)		-	$\pm 3.3$	-	%
$D_{\text{max}}$	Maximum Duty-cycle		62	67	72	%

## FEEDBACK SECTION

$R_{\text{up}}$	Internal pull-up resistor	4	-	18	-	k $\Omega$
$t_{\text{ss}}$	Internal soft-start (guaranteed by design)	-	-	1.0	-	ms

## SKIP CYCLE GENERATION

$V_{\text{skip}}$	Default skip mode level on FB pin	4		0.5		V
-------------------	-----------------------------------	---	--	-----	--	---

## TEMPERATURE MANAGEMENT

TSD	Temperature shutdown			150		$^{\circ}\text{C}$
	Hysteresis in shutdown			50		$^{\circ}\text{C}$

2. See characterization curves for temperature evolution

# NCP1015

## TYPICAL CHARACTERISTICS

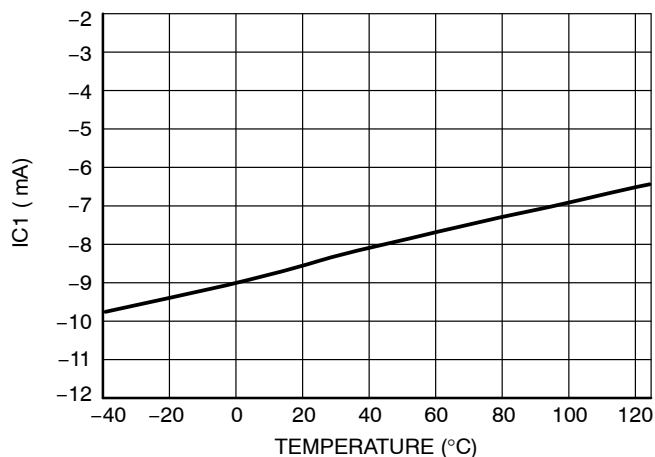

Figure 3.  $I_{C1}$  @  $V_{CC} = 8.0$  V,  $FB = 1.5$  V vs. Temperature

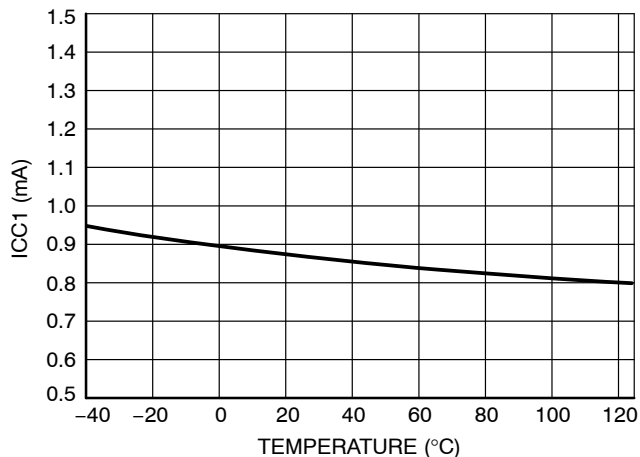

Figure 4.  $I_{CC1}$  @  $V_{CC} = 8.0$  V,  $FB = 1.5$  V vs. Temperature

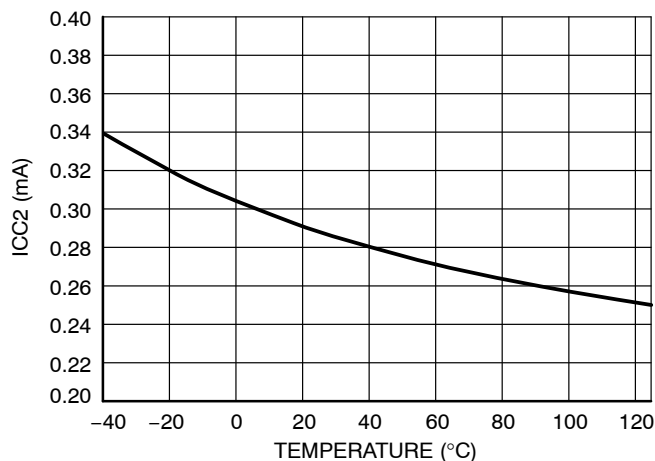

Figure 5.  $I_{CC2}$  @  $V_{CC} = 6.0$  V,  $FB = \text{Open}$  vs. Temperature

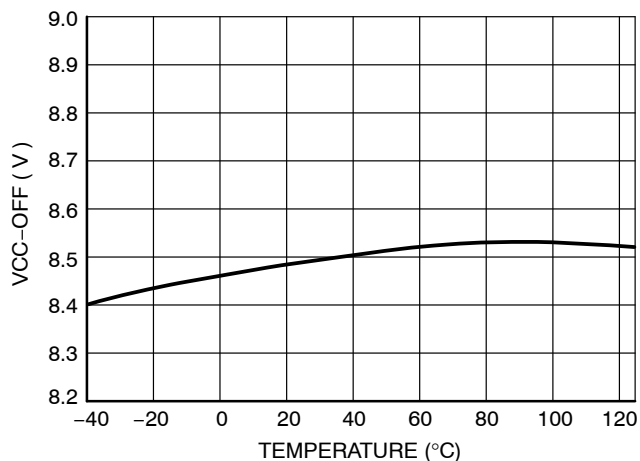

Figure 6.  $V_{CC-OFF}$ ,  $FB = 1.5$  V vs. Temperature

# NCP1015

## TYPICAL CHARACTERISTICS

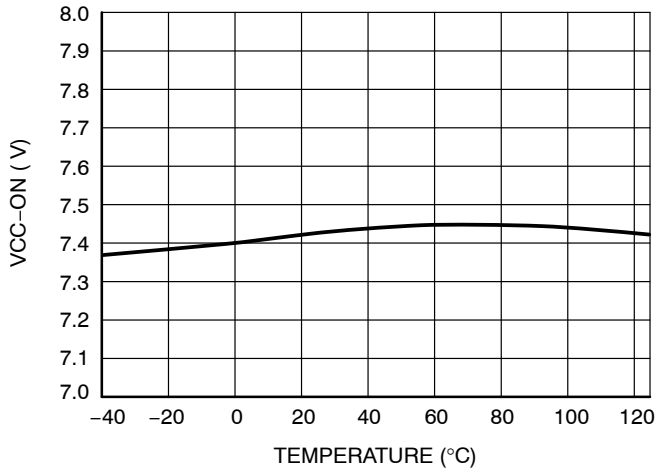

Figure 7. V<sub>CC</sub> ON, FB = 3.5 V vs. Temperature

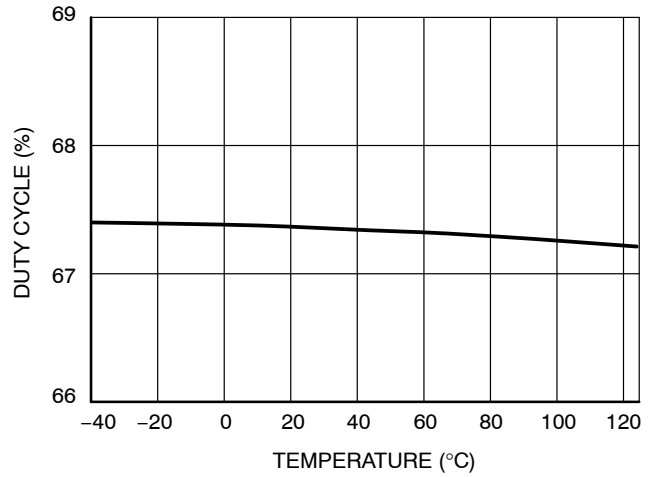

Figure 8. Duty Cycle vs. Temperature

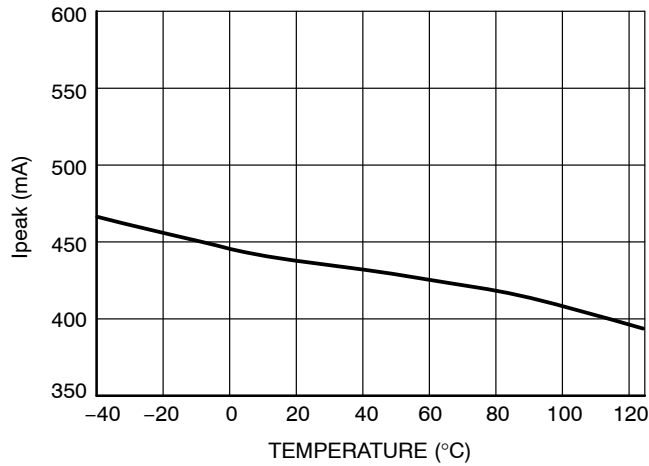

Figure 9. I<sub>peak-RR</sub>, V<sub>CC</sub> = 8.0 V, FB = 3.5 V vs. Temperature

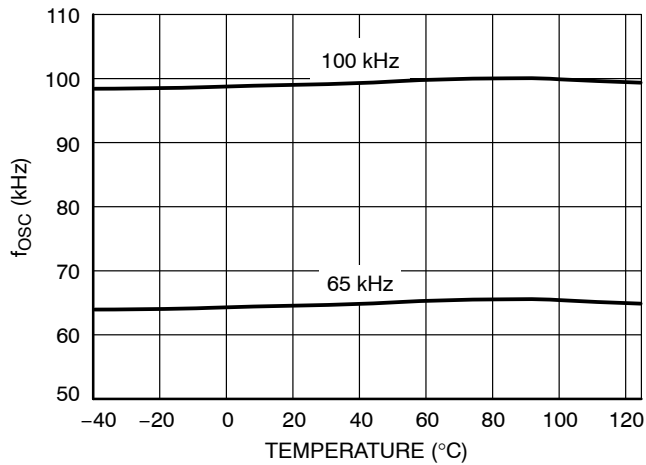

Figure 10. Frequency vs. Temperature

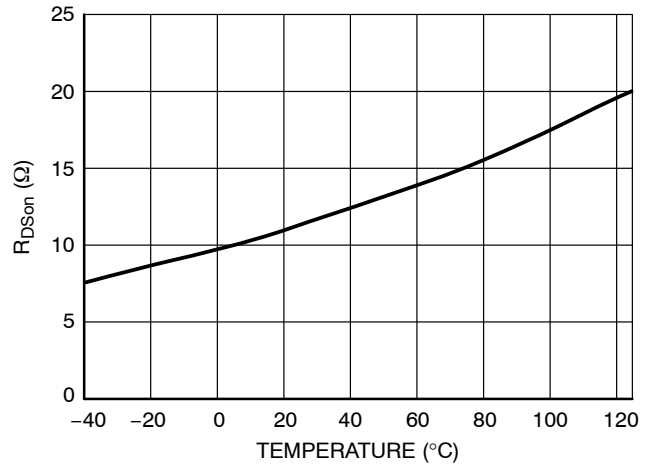

Figure 11. ON Resistance vs. Temperature

## APPLICATION INFORMATION

## Introduction

The NCP1015 offers a complete current-mode control solution (actually an enhanced NCP1200 controller section) together with a high-voltage power MOSFET in a monolithic structure. The component integrates everything needed to build a rugged and low-cost Switch-Mode Power Supply (SMPS) featuring low standby power. The quick selection table details the differences in operating frequency.

- No need for an auxiliary winding: ON Semiconductor Very High Voltage Integrated Circuit technology lets you supply the IC directly from the high-voltage dc rail. We call it Dynamic Self-Supply (DSS). This solution simplifies the transformer design and ensures a better control of the SMPS in difficult output conditions, e.g. constant current operations. However, for improved standby performance, an auxiliary winding can be connected to the  $V_{CC}$  pin to disable the DSS operation.
- Short-circuit protection: by permanently monitoring the feedback line activity, the IC is able to detect the presence short-circuit, immediately reducing the output power for a total system protection. Once the short has disappeared, the controller resumes and goes back to normal operation.
- Low standby-power: If SMPS naturally exhibit a good efficiency at nominal load, they begin to be less efficient when the output power demand diminishes. By skipping un-needed switching cycles, the NCP1015 drastically reduces the power wasted during light load conditions. An auxiliary winding can further help decreasing the standby power to extremely low levels by invalidating the DSS operation. Typical measurements show results below 80 mW @ 230 Vac for a typical 7 W universal power supply.
- No acoustic noise while operating: Instead of skipping cycles at high peak currents, the NCP1015 waits until the peak current demand falls below a fixed 0.25 of the maximum limit. As a result, cycle skipping can take place without having a singing transformer. You can thus select cheap magnetic components free of noise problems.
- SPICE model: a dedicated model to run transient cycle-by-cycle simulations is available but also an

averaged version to help you closing the loop.

Ready-to-use templates can be downloaded in OrCAD's PSpice, and INTUSOFT's IsSpice4 from ON Semiconductor web site, NCP1015 related section.

## Dynamic Self-Supply

When the power supply is first powered from the mains outlet, the internal current source (typically 8 mA) is biased and charges up the  $V_{CC}$  capacitor from the drain pin. Once the voltage on this  $V_{CC}$  capacitor reaches the  $V_{CC(off)}$  level (typically 8.5 V), the current source turns off and pulses are delivered by the output stage: the circuit is awake and activates the power MOSFET. Figure 12 details the internal circuitry:

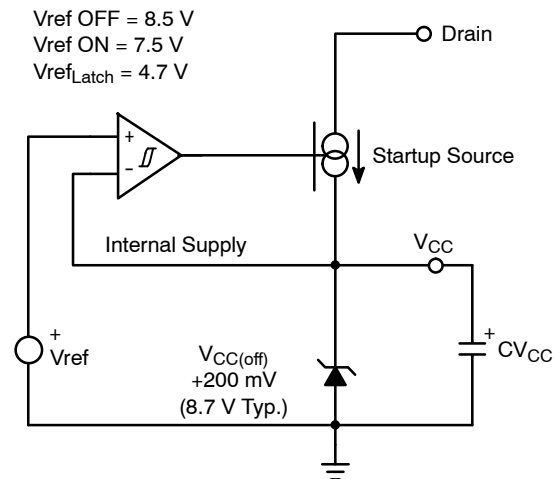
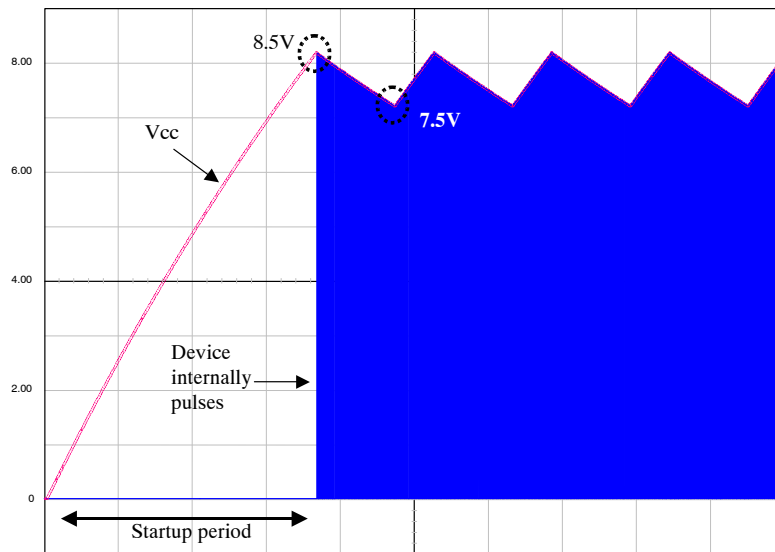

Figure 12. The Current Source Regulates  $V_{CC}$  by Introducing a Ripple

Being loaded by the circuit consumption, the voltage on the  $V_{CC}$  capacitor goes down. When the DSS controller detects that  $V_{CC}$  has reached 7.5 V ( $V_{CC(on)}$ ), it activates the internal current source to bring  $V_{CC}$  toward 8.5 V and stops again: a cycle takes place whose low frequency depends on the  $V_{CC}$  capacitor and the IC consumption. A 1 V ripple takes place on the  $V_{CC}$  pin whose average value equals  $(V_{CC(off)} + V_{CC(on)}) / 2$ . Figure 13 shows a typical operation of the DSS.

# NCP1015



**Figure 13. The Charge/Discharge Cycle over a 10 µF V<sub>CC</sub> Capacitor**

As one can see, the V<sub>CC</sub> capacitor shall be dimensioned to offer an adequate startup time, i.e. ensure regulation is reached before V<sub>CC</sub> crosses 7.5 V (otherwise the part enters the fault condition mode). If we know that  $\Delta V = 1 \text{ V}$  and ICC1 is 1.2 mA (for instance we selected a 11 Ω device switching at 65 kHz), then the V<sub>CC</sub> capacitor can be calculated using:

$$C \geq \frac{ICC1 \cdot t_{\text{startup}}}{\Delta V} \quad (\text{eq. 1})$$

Let's suppose that the SMPS needs 10 ms to startup, then we will calculate C to offer a 15 ms period. As a result, C should be greater than 18 µF thus the selection of a 33 µF / 16 V capacitor is appropriate.

### Short Circuit Protection

The internal protection circuitry involves a patented arrangement that permanently monitors the assertion of an internal error flag. This error flag is, in fact, a signal that instructs the controller that the internal maximum peak current limit is reached. This naturally occurs during the startup period (V<sub>out</sub> is not stabilized to the target value) or when the optocoupler LED is no longer biased, e.g in a short-circuit condition or when the feedback network is broken. When the DSS normally operates, the logic checks for the presence of the error flag every time V<sub>CC</sub> crosses V<sub>CC(on)</sub>. If the error flag is low (peak limit not active) then the IC works normally. If the error signal is active, then the NCP1015 immediately stops the output pulses, reduces its internal current consumption and does not allow the startup source to activate: V<sub>CC</sub> drops toward ground until it reaches

the so-called latch-off level, where the current source activates again to attempt a new re-start. If the error has gone, the IC automatically resumes its operation. If the default is still there, the IC pulses during 8.5 V down to 7.5 V and enters a new latch-off phase. The resulting burst operation guarantees a low average power dissipation and lets the SMPS sustain a permanent short-circuit. Figure 14 presents the corresponding diagram:

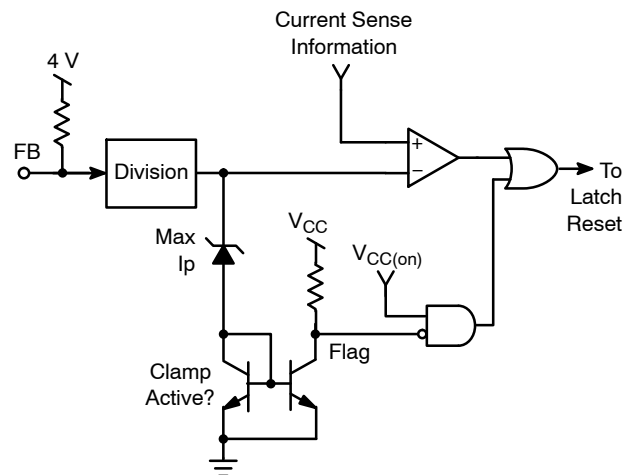

**Figure 14. Simplified NCP1015 Short-Circuit Detection Circuitry**

The protection burst duty-cycle can easily be computed through the various timing events as portrayed by Figure 15:



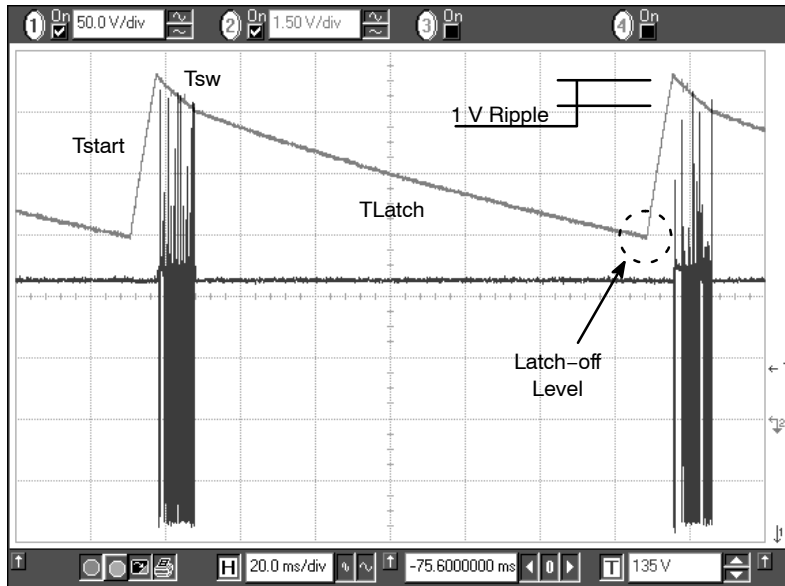

Figure 15. NCP1015 Facing a Fault Condition ( $V_{in} = 150 \text{ Vdc}$ )

The rising slope from the latch-off level up to 8.5 V is expressed by:

$$P_{DSS} = V_{in} \cdot ICC1$$

$$t_{start} = \frac{\Delta V1 \cdot C}{ICC1}$$

The time during which the IC actually pulses is given by:

$$t_{sw} = \frac{\Delta V2 \cdot C}{ICC1}$$

Finally, the latch-off time can be derived using the same formula topology:

$$t_{latch} = \frac{\Delta V3 \cdot C}{ICC2}$$

From these three definitions, the burst duty-cycle  $D$  can be computed:

$$D = \frac{t_{sw}}{t_{start} + t_{sw} + t_{latch}} \quad (\text{eq. 2})$$

$$D = \frac{\Delta V2}{ICC1 \cdot \left( \frac{\Delta V2}{ICC1} + \frac{\Delta V1}{IC1} + \frac{\Delta V3}{ICC2} \right)} \quad (\text{eq. 3})$$

Feeding the equation with values extracted from the parameter section gives a typical duty-cycle  $D$  of 13%, precluding any lethal thermal runaway while in a fault condition.

### DSS Internal Dissipation

The Dynamic Self-Supplied pulls the energy out from the drain pin. In the Flyback-based converters, this drain level can easily go above 600 V peak and thus increase the stress on the DSS startup source. However, the drain voltage evolves with time and its period is small compared to that of the DSS. As a result, the averaged dissipation, excluding capacitive losses, can be derived by:

$$P_{DSS} = ICC1 \cdot \langle V_{DS(t)} \rangle \quad (\text{eq. 4})$$

Figure 16 shows a typical drain-ground wave-shape where leakage effects have been removed:

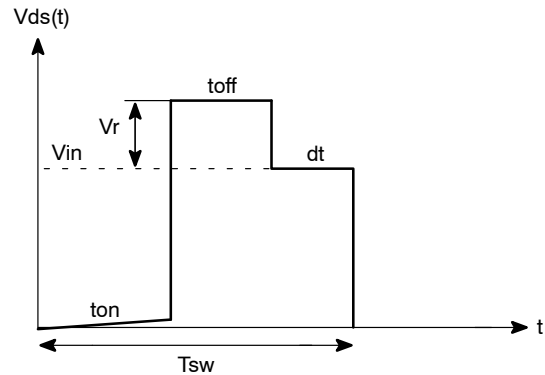

Figure 16. A Typical Drain-ground Waveshape where Leakage Effects are Not Accounted for

By looking at Figure 16 the average result can easily be derived by additive square area calculation:

$$\langle V_{DS(t)} \rangle = V_{in} \cdot (1 - D) + V_r \cdot \frac{t_{off}}{t_{sw}} \quad (\text{eq. 5})$$

By developing Equation 5 we obtain:

$$\langle V_{DS(t)} \rangle = V_{in} - V_{in} \cdot \frac{t_{on}}{t_{sw}} + V_r \cdot \frac{t_{off}}{t_{sw}} \quad (\text{eq. 6})$$

$t_{off}$  can be expressed by:

$$t_{off} = I_p \cdot \frac{L_p}{V_r} \quad (\text{eq. 7})$$

$t_{on}$  can be evaluated by:

$$t_{on} = I_p \cdot \frac{L_p}{V_{in}} \quad (\text{eq. 8})$$

Plugging Equation 7 and Equation 8 into Equation 6 leads to  $\langle V_{ds(t)} \rangle = V_{in}$  and thus:

$$P_{DSS} = V_{in} \cdot ICC1 \quad (\text{eq. 9})$$

The worse case occurs at high line, when  $V_{in}$  equals 370 Vdc. With  $ICC1 = 1.2 \text{ mA}$  (65 kHz version), we can expect a DSS dissipation around 440 mW. If you select a higher switching frequency version, the  $ICC1$  increases and it is likely that the DSS consumption exceeds 500 mW. In that case, we recommend adding an auxiliary winding in order to offer more dissipation room to the power MOSFET.

Please read application note AND8125/D “Evaluating the power capability of the NCP101X members” to help selecting the right part / configuration for your application.

### Lowering the Standby Power with an Auxiliary Winding

The DSS operation can bother the designer when a) its dissipation is too high b) extremely low standby power is a must. In both cases, one can connect an auxiliary winding to disable the self-supply. The current source then ensures the startup sequence only and stays in the off state as long as  $V_{CC}$  does not drop below  $V_{CC(on)}$  or 7.5 V. Figure 17 shows that the insertion of a resistor ( $R_{limit}$ ) between the auxiliary dc level and the  $V_{CC}$  pin is mandatory a) not to damage the internal 8.7 V zener diode during an overshoot for instance (absolute maximum current is 15 mA) b) to implement the fail-safe optocoupler protection as offered by the active clamp. Please note that there cannot be bad interaction between the clamping voltage of the internal zener and  $V_{CC(off)}$  since this clamping voltage is actually built on top of  $V_{CC(off)}$  with a fixed amount of offset (200 mV typical).

Self-supplying controllers in extremely low standby applications often puzzles the designer. Actually, if a SMPS operated at nominal load can deliver an auxiliary voltage of an arbitrary 16 V ( $V_{nom}$ ), this voltage can drop to below 10 V ( $V_{stby}$ ) when entering standby. This is because the recurrence of the switching pulses expands so much that the low frequency re-fueling rate of the  $V_{CC}$  capacitor is not enough to keep a proper auxiliary voltage. Figure 18 shows a typical scope shot of a SMPS entering deep standby (output un-loaded). So care must be taken when calculating  $R_{limit}$  1) to not exceed the maximum pin current in normal operation but 2) not to drop too much voltage over  $R_{limit}$  when entering standby. Otherwise the DSS could reactivate and the standby performance would degrade. We are thus able to bound  $R_{limit}$  between two equations:

$$\frac{V_{nom} - V_{clamp}}{I_{trip}} \leq R_{lim} \leq \frac{V_{stby} - V_{CC(on)}}{ICC1} \quad (\text{eq. 10})$$

Where:

$V_{nom}$  is the auxiliary voltage at nominal load

$V_{stby}$  is the auxiliary voltage when standby is entered

$I_{trip}$  is the current corresponding to the nominal operation. It thus must be selected to avoid false tripping in overshoot conditions.

$ICC1$  is the controller consumption. This number slightly decreases compared to  $ICC1$  from the spec since the part in standby does almost not switch.

$V_{CC(on)}$  is the level above which  $V_{aux}$  must be maintained to keep the DSS in the OFF mode. It is good to shoot around 8 V in order to offer an adequate design margin, e.g. to not re-activate the startup source (which is not a problem in itself if low standby power does not matter)

Since  $R_{limit}$  shall not bother the controller in standby, e.g. keep  $V_{aux}$  to around 8 V (as selected above), we purposely select a  $V_{nom}$  well above this value. As explained before, experience shows that a 40% decrease can be seen on auxiliary windings from nominal operation down to standby mode. Let's select a nominal auxiliary winding of 20 V to offer sufficient margin regarding 8 V when in standby ( $R_{limit}$  also drops voltage in standby). Plugging the values in Equation 10 gives the limits within which  $R_{limit}$  shall be selected:

$$\frac{20 - 8.7}{6.3 \text{ m}} \leq R_{limit} \leq \frac{12 - 8}{1.1 \text{ m}} \quad (\text{eq. 11})$$

that is to say:  $1.8 \text{ k}\Omega < R_{limit} < 3.6 \text{ k}\Omega$ .

If we are designing a power supply delivering 12 V, then the ratio auxiliary/power must be:  $12 / 20 = 0.6$ . The  $ICC$  current has to not exceed 6.4 mA. This will occur when  $V_{aux}$  grows-up to:  $8.7 \text{ V} + 1.8 \text{ k} \times (6.4 \text{ m} + 1.1 \text{ m}) = 22.2 \text{ V}$  for the first boundary or  $8.7 \text{ V} + 3.6 \text{ k} \times (6.4 \text{ m} + 1.1 \text{ m}) = 35.7 \text{ V}$  for second boundary. On the power output, it will respectively give  $22.6 \times 0.6 = 13.3 \text{ V}$  and  $35.7 \times 0.6 = 21.4 \text{ V}$ . As one can see, tweaking the  $R_{limit}$  value will allow the selection of a given overvoltage output level. Theoretically predicting the auxiliary drop from nominal to standby is an almost impossible exercise since many parameters are involved, including the converter time constants. Fine tuning of  $R_{limit}$  thus requires a few iterations and experiments on a breadboard to check  $V_{aux}$  variations but also output voltage excursion in fault. Once properly adjusted, the fail-safe protection will preclude any lethal voltage runaways in case a problem would occur in the feedback loop.

## NCP1015

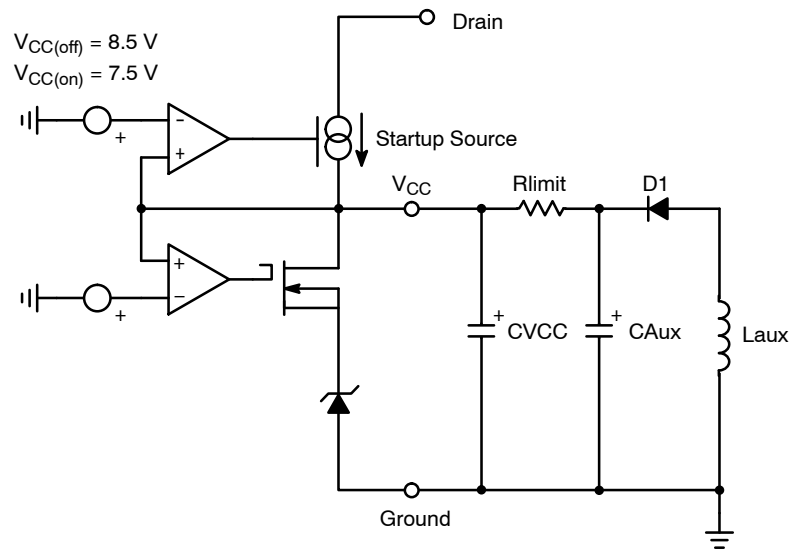

Figure 17. A Detailed View of the NCP1015 with Properly Connected Auxiliary Winding

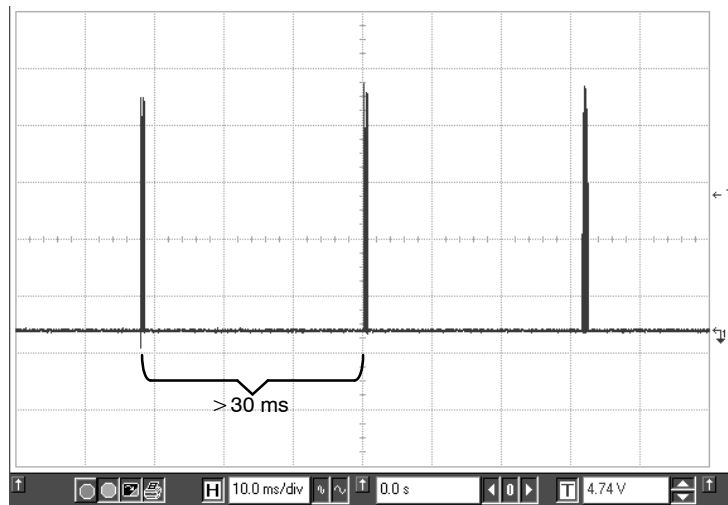

Figure 18. The Burst Frequency becomes So Low that it is Difficult to Keep an Adequate Level on the Auxiliary VCC

### Lowering the Standby Power with Skip-cycle

Skip cycle offers an efficient way to reduce the standby power by skipping unwanted cycles at light loads. However, the recurrent frequency in skip often enters the audible range and a high peak current obviously generates acoustic noise in the transformer. The noise takes its origins in the resonance of the transformer mechanical structure which is

excited by the skipping pulses. A possible solution, successfully implemented in the NCP1200 series, also authorizes skip cycle but only when the power demand as dropped below a given level. At this time, the peak current is reduced and no noise can be heard. Figure 19 shows the peak current evolution of the NCP1015 entering standby:

# NCP1015

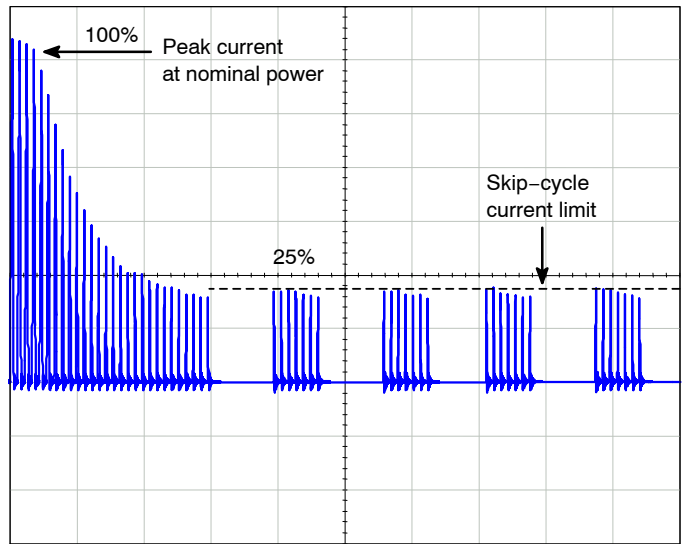

**Figure 19. Low Peak Current Skip-Cycle Guarantees Noise-Free Operation**

Full power operation involves the nominal switching frequency and thus avoids any noise when running.

Experiments carried on a 5 W universal mains board unveiled a standby power of 300 mW @ 230 Vac with the DSS activated and dropped to less than 100 mW when an auxiliary winding is connected.

### Frequency Jittering for Improved EMI Signature

By sweeping the switching frequency around its nominal value, it spreads the energy content on adjacent frequencies rather than keeping it centered in one single ray. This offers

the benefit to artificially reduce the measurement noise on a standard EMI receiver and pass the tests more easily. The EMI sweep is implemented by routing the  $V_{CC}$  ripple (induced by the DSS activity) to the internal oscillator. As a result, the switching frequency moves up and down to the DSS rhythm. Typical deviation is  $\pm 4\%$  of the nominal frequency. With a 1 V peak-to-peak ripple, the frequency will equal 65 kHz in the middle of the ripple and will increase as  $V_{CC}$  rises or decrease as  $V_{CC}$  ramps down. Figure 20 shows the behavior we have adopted:

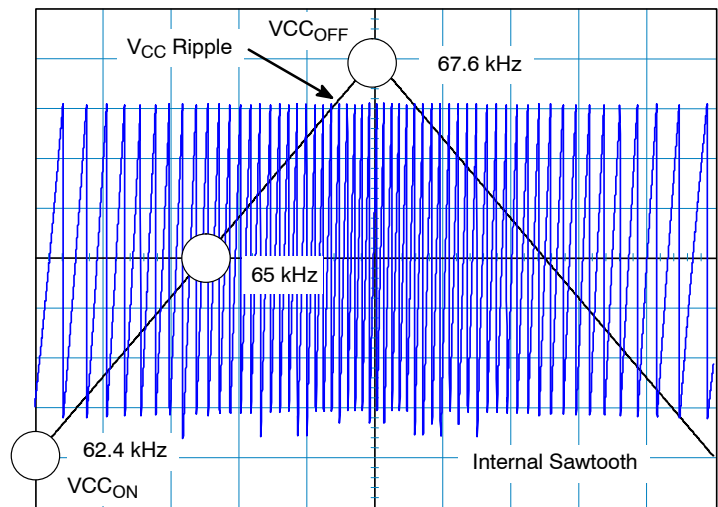
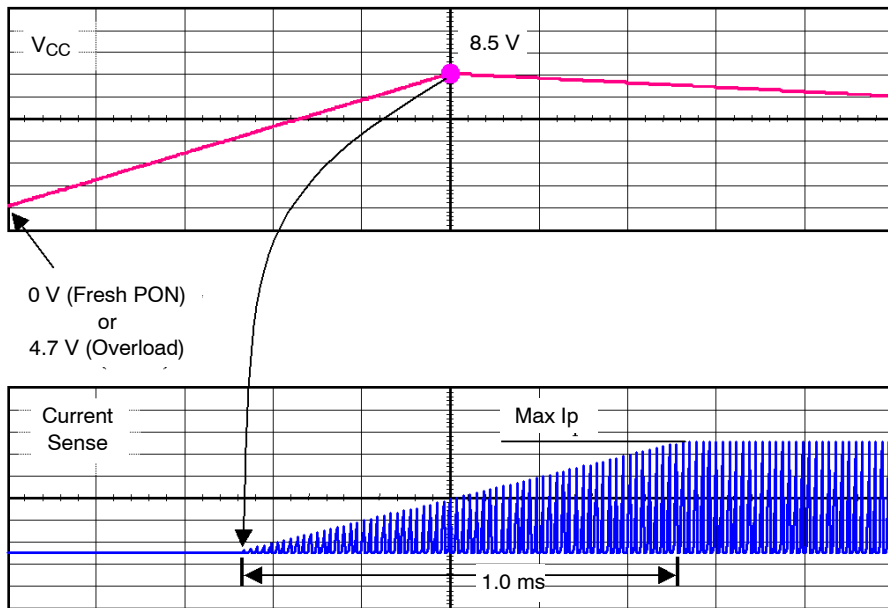

**Figure 20. The  $V_{CC}$  Ripple Causes the Frequency Jittering on the Internal Oscillator Saw-tooth (65 kHz version)**

**Soft-Start**

The NCP1015 features an internal 1 ms soft-start activated during the power on sequence ( $P_{ON}$ ). As soon as  $V_{CC}$  reaches  $V_{CC(off)}$ , the peak current is gradually increased from nearly zero up to the maximum internal clamping level (e.g. 350 mA). This situation lasts 1 ms and further to that time period, the peak current limit is blocked to the maximum until the supply enters regulation. The

soft-start is also activated during the over current burst (OCP) sequence. Every re-start attempt is followed by a soft-start activation. Generally speaking, the soft-start will be activated when  $V_{CC}$  ramps up either from zero (fresh power-on sequence) or 4.5 V, the latch-off voltage occurring during OCP. Figure 21 shows the soft-start behavior. The time scales are purposely shifted to offer a better zoom portion.

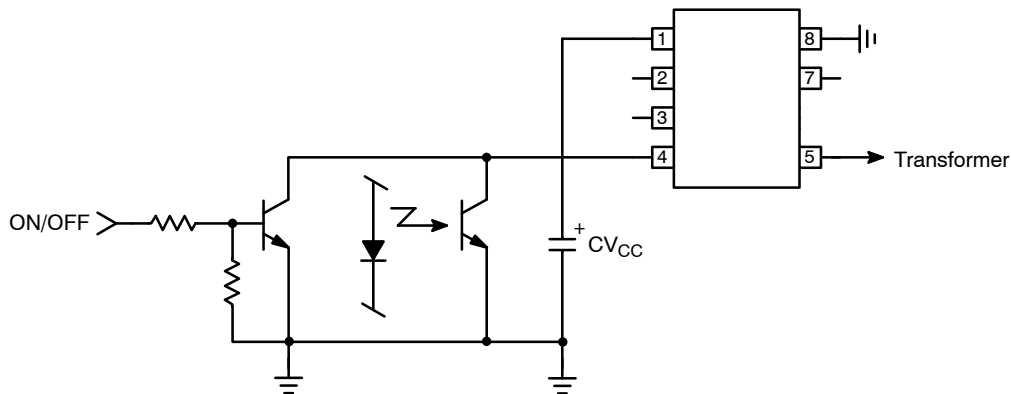

**Figure 21. Soft-Start is Activated During a Start-up Sequence or an OCP Condition**

**Non-latching Shutdown**

In some cases, it might be desirable to shut off the part temporarily and authorize its re-start once the default has disappeared. This option can easily be accomplished through a single NPN bipolar transistor wired between FB

and ground. By pulling FB below the internal skip level ( $V_{skip}$ ), the output pulses are disabled. As soon as FB is relaxed, the IC resumes its operation. Figure 22 shows the application example:



**Figure 22. A Non-latching Shutdown where Pulses are Stopped as long as the NPN is Biased**

**Full Latching Shutdown**

Other applications require a full latching shutdown, e.g. when an abnormal situation is detected (over temp or overvoltage). This feature can easily be implemented through two external transistors wired as a discrete SCR.

When the OVP level exceeds the zener breakdown voltage, the NPN biases the PNP and fires the equivalent SCR, permanently bringing down the FB pin. The switching pulses are disabled until the user un-plugs the power supply.

## NCP1015

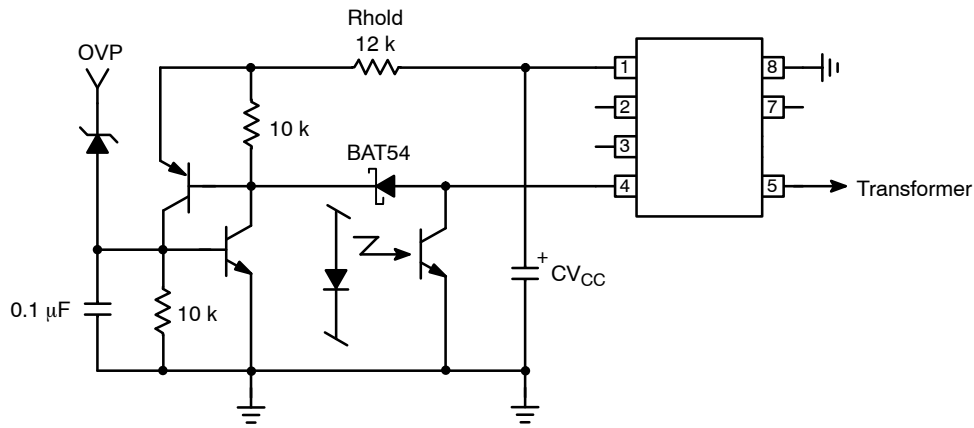

**Figure 23. Two Bipolar Transistors Ensures a Total Latch-off of the SMPS in Presence of an OVP**

$R_{hold}$  ensures that the SCR stays on when fired. The bias current flowing through  $R_{hold}$  should be small enough to let the  $V_{CC}$  ramp up (8.5 V) and down (7.5 V) when the SCR is fired. The NPN base can also receive a signal from a temperature sensor. Typical bipolar can be MMBT2222 and MMBT2907 for the discrete latch. The NST3946 features two bipolar NPN + PNP in the same package and could also be used.

### Power Dissipation and Heatsinking

The power dissipation of NCP1015 consists of the dissipation DSS current-source (when active) and the dissipation of MOSFET. Thus  $P_{tot} = P_{DSS} + P_{MOSFET}$ . When the PDIP7 package is surrounded by copper, it becomes possible to drop its thermal resistance junction-to-ambient,  $R_{\theta JA}$  down to  $75^{\circ}\text{C}/\text{W}$  and thus dissipate more power. The maximum power the device can thus evacuate is:

$$P_{max} = \frac{T_{J(max)} - T_{AMB(max)}}{R_{\theta JA}} \quad (\text{eq. 12})$$

which gives around 1 W for an ambient of  $50^{\circ}\text{C}$ . The losses inherent to the MOSFET  $R_{DS(on)}$  can be evaluated using the following formula:

$$P_{mos} = \frac{1}{3} \cdot I_p^2 \cdot D \cdot R_{DS(on)} \quad (\text{eq. 13})$$

where  $I_p$  is the worse case peak current (at the lowest line input),  $D$  is the converter operating duty-cycle and  $R_{DS(on)}$  the MOSFET resistance for  $T_J = 100^{\circ}\text{C}$ . This formula is only valid for Discontinuous Conduction Mode (DCM) operation where the turn-on losses are null (the primary current is zero when you re-start the MOSFET). Figure 24 gives a possible layout to help dropping the thermal resistance. When measured on a  $35 \mu\text{m}$  (1 oz.) copper thickness PCB, we obtained a thermal resistance of  $75^{\circ}\text{C}/\text{W}$ :

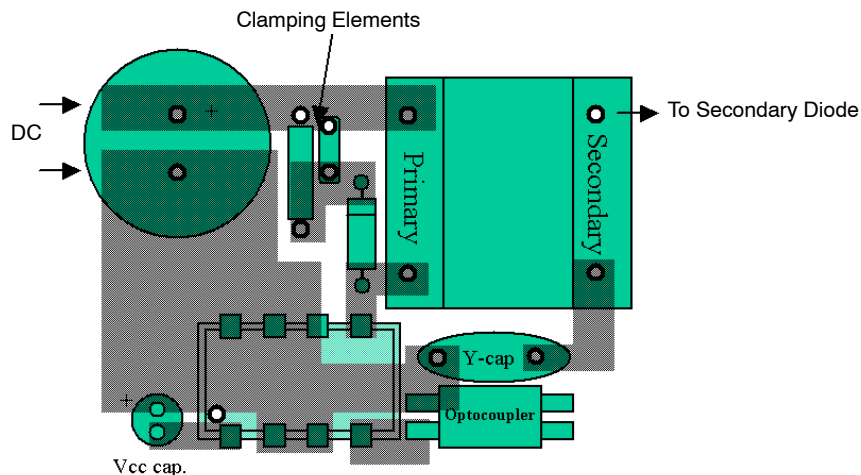

**Figure 24. A Possible PCB Arrangement to Reduce the Thermal Resistance Junction-to-Ambient**

### Design Procedure

The design of a SMPS around a monolithic device does not differ from that of a standard circuit using a controller and a MOSFET. However, one needs to be aware of certain characteristics specific of monolithic devices:

1. In any case, the lateral MOSFET body-diode shall never be forward biased, either during start-up (because of a large leakage inductance) or in normal operation as shown by Figure 25.

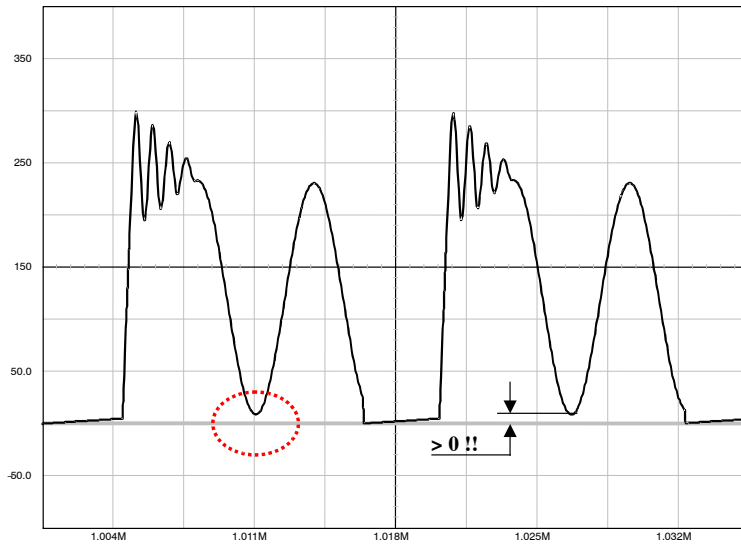

Figure 25. The Drain–Source Wave Shall Always be Positive . . .

As a result, the Flyback voltage which is reflected on the drain at the switch opening cannot be larger than the input voltage. When selecting components, you thus must adopt a turn ratio which adheres to the following equation:

$$N \cdot (V_{out} + V_f) < V_{IN(min)} \quad (\text{eq. 14})$$

For instance, if you operate from a 120 V dc rail and you deliver 12 V, we can select a reflected voltage of 100 VDC maximum:  $120 - 100 > 0$ . Therefore, the turn ratio  $N_p : N_s$  must be smaller than  $100 / (12 + 1) = 7.7$  or  $N_p : N_s < 7.7$ . We will see later on how it affects the calculation.

2. Current–mode architecture is, by definition, sensitive to subharmonic oscillations. Subharmonic oscillations only occur when the SMPS is operating in Continuous Conduction Mode (CCM) together with a duty–cycle greater than 50%. As a result, we recommend operating the device in DCM only, whatever duty–cycle it implies (max. = 65%).
3. Lateral Mosfets have a poorly doped body–diode which naturally limits their ability to sustain the avalanche. A traditional RCD clamping network shall thus be installed to protect the MOSFET. In some low power applications, a simple capacitor can also be used since:

$$V_{DRAIN(max)} = V_{in} + N \cdot (V_{out} + V_f) + I_p \cdot \sqrt{\frac{L_f}{C_{tot}}} \quad (\text{eq. 15})$$

where  $L_f$  is the leakage inductance,  $C_{tot}$  the total capacitance at the drain node (which is increased by the capacitor you will wire between drain and source),  $N$  the  $N_p : N_s$  turn ratio,  $V_{out}$  the output voltage,  $V_f$  the secondary diode forward drop and finally,  $I_p$  the maximum peak current. Worst case occurs when the SMPS is very close to regulation,

e.g. the  $V_{out}$  target is almost reached and  $I_p$  is still pushed to the maximum.

Taking into account all previous remarks, it becomes possible to calculate the maximum power that can be transferred at low line:

When the switch closes,  $V_{in}$  is applied across the primary inductance  $L_p$  until the current reaches the level imposed by the feedback loop. The duration of this event is called the ON time and can be defined by:

$$t_{on} = \frac{L_p \cdot I_p}{V_{in}} \quad (\text{eq. 16})$$

At the switch opening, the primary energy is transferred to the secondary and the flyback voltage appears across  $L_p$ , resetting the transformer core with a slope of:

$$\frac{N \cdot (V_{out} + V_f)}{L_p} \cdot t_{off}$$

the  $t_{off}$  time is thus:

$$t_{off} = \frac{L_p \cdot I_p}{N \cdot (V_{out} + V_f)} \quad (\text{eq. 17})$$

If one wants to keep DCM only, but still need to pass the maximum power, we will not allow a dead–time after the core is reset, but rather immediately re–start. The switching time  $t_{sw}$  can be expressed by:

$$t_{sw} = t_{off} + t_{on} = L_p \cdot I_p \cdot \left( \frac{1}{V_{in}} + \frac{1}{N \cdot (V_{out} + V_f)} \right) \quad (\text{eq. 18})$$

The Flyback transfer formula dictates that:

$$\frac{P_{out}}{\eta} = \frac{1}{2} \cdot L_p \cdot I_p^2 \cdot f_{sw} \quad (\text{eq. 19})$$

which, by extracting  $I_p$  and plugging into Equation 19 leads to:

$$t_{sw} = L_p \sqrt{\frac{2 \cdot P_{out}}{\eta \cdot f_{sw} \cdot L_p}} \cdot \left( \frac{1}{V_{in}} + \frac{1}{N \cdot (V_{out} + V_f)} \right) \quad (\text{eq. 20})$$

Extracting  $L_p$  from Equation 20 gives:

## NCP1015

$$L_{P(critical)} = \frac{(V_{in} \cdot V_r)^2 \cdot \eta}{2 \cdot f_{sw} \cdot [P_{out} \cdot (V_r^2 + 2 \cdot V_r \cdot V_{in} + V_{in}^2)]} \quad (\text{eq. 21})$$

with  $V_r = N \cdot (V_{out} + V_f)$  and  $\eta$  the efficiency.

If  $L_p$  critical gives the inductance value above which DCM operation is lost, there is another expression we can write to connect  $L_p$ , the primary peak current bounded by the NCP1015 and the maximum duty-cycle that needs to stay below 50%:

$$L_{P(max)} = \frac{D_{max} \cdot V_{IN(min)} \cdot t_{sw}}{I_{P(max)}} \quad (\text{eq. 22})$$

$$P_{max} = t_{sw}^2 \cdot V_{IN(min)}^2 \cdot V_r^2 \cdot \eta \cdot \frac{f_{sw}}{(2L_{P(max)}V_r^2 + 4L_{P(max)}V_rV_{IN(min)} + V_{IN(min)}^2)} \quad (\text{eq. 23})$$

From Equation 22 we obtain the operating duty-cycle D:

$$D = \frac{I_p \cdot L_p}{V_{in} \cdot t_{sw}} \quad (\text{eq. 24})$$

This lets us calculate the RMS current circulating in the MOSFET:

$$I_{D(rms)} = I_p \cdot \sqrt{\frac{D}{3}} \quad (\text{eq. 25})$$

From this equation, we obtain the average dissipation in the MOSFET:

$$P_{avg} = \frac{1}{3} \cdot I_p^2 \cdot D \cdot R_{DS(on)} \quad (\text{eq. 26})$$

to which switching losses shall be added.

If we stick to Equation 23, compute  $L_p$  and follow the above calculations, we will discover that a power supply built with the NCP1015 and operating from a 100 Vac line minimum will not be able to deliver more than 7 W continuous, regardless of the selected switching frequency (however the transformer core size will go down as  $f_{sw}$  is increased). This number grows up significantly when operated from single European mains (18 W).

*For more different flyback converters then are the below examples we recommend use following support:*

- 1) Application note AND8125/D “Evaluating the power capability of the NCP101X members”
- 2) Application note AND8134/D “Designing Converters with the NCP101X members.”
- 3) Application note AND8142/D “A 6W/12W Universal mains adapter with NCP101X series”.
- 4) The PSpice or Orcad simulation models

### Example 1.: A 12 V 7.0 W SMPS Operating on a Large Mains with NCP1015:

$V_{in} = 100 \text{ Vac} \div 250 \text{ Vac}$  or  $140 \text{ Vdc} \div 350 \text{ Vdc}$  once rectified, assuming a low bulk ripple

Efficiency = 80%

$V_{out} = 12 \text{ V}$ ,  $I_{out} = 580 \text{ mA}$

$f_{sw} = 65 \text{ kHz}$

$I_{P(max)} = 450 \text{ mA} - 10\% = 405 \text{ mA}$

where  $V_{IN(min)}$  corresponds to the lowest bulk voltage, hence the longest  $t_{on}$  duration or largest duty-cycle.  $I_{P(max)}$  is the available peak current from the considered part, e.g. 450 mA typical for the NCP1015 (however, the minimum value of this parameter shall be considered for reliable evaluation). Combining Equations 21 and 22 gives the maximum theoretical power you can pass respecting the peak current capability of the NCP1015, the maximum duty-cycle and the discontinuous mode operation:

Applying the above equations leads to :

Selected maximum reflected voltage = 120 V

with  $V_{out} = 12 \text{ V}$ , secondary drop = 0.5 V  $\rightarrow N_p : N_s = 1 : 0.1$

$L_p$  critical = 3.9 mH

$I_p = 250 \text{ mA}$

$D_{max} = 0.39$

$I_{DRAIN(rms)} = 90 \text{ mA}$

$P_{MOSFET} = 202 \text{ mW}$  at  $R_{DS(on)} = 25 \Omega$  ( $T_J > 100^\circ\text{C}$ )

$P_{DSS} = 1.2 \text{ mA} \times 350 \text{ V} = 420 \text{ mW}$ , if DSS is used

Secondary diode voltage stress =  $(350 \times 0.1) + 12 = 47 \text{ V}$   
(e.g. a MBRS360T3, 3 A / 60 V would fit)

### Example 2.: A 12 V 16 W SMPS Operating on Narrow European Mains with NCP1015:

$V_{in} = 230 \text{ Vac} \pm 15\%$ , or  $276 \text{ Vdc} \div 370 \text{ Vdc}$

Efficiency = 80%

$V_{out} = 12 \text{ V}$ ,  $I_{out} = 1.25 \text{ A}$

$f_{sw} = 65 \text{ kHz}$

$I_{P(max)} = 450 \text{ mA} - 10\% = 405 \text{ mA}$

Applying the equations leads to :

Selected maximum reflected voltage = 250 V

with  $V_{out} = 12 \text{ V}$ , secondary drop = 0.5 V  $\rightarrow N_p : N_s = 1:0.05$

$L_p = 7,2 \text{ mH}$

$I_p = 0.27 \text{ mA}$

$D_{max} = 0.41$

$I_{DRAIN(rms)} = 100 \text{ mA}$

$P_{MOSFET} = 250 \text{ mW}$  at  $R_{DS(on)} = 25 \Omega$  ( $T_J > 100^\circ\text{C}$ )

$P_{DSS} = 1.2 \text{ mA} \times 370 \text{ V} = 444 \text{ mW}$ , if DSS is used below an ambient of  $50^\circ\text{C}$ .

Secondary diode voltage stress =  $(370 \times 0.05) + 12 = 30.5 \text{ V}$   
(e.g. a MBRS340T3, 3 A / 40 V)



## NCP1015

Please note that these calculations assume a flat DC rail whereas a 10 ms ripple naturally affects the final voltage available on the transformer end. Once the Bulk capacitor has been selected, one should check that the resulting ripple (min  $V_{\text{bulk}}$ ) is still compatible with the above calculations. As an example, to benefit from the largest operating range, a 7 W board was built with a 47  $\mu\text{F}$  bulk capacitor which ensured discontinuous operation even in the ripple minimum waves.

### MOSFET Protection

As in any Flyback design, it is important to limit the drain excursion to a safe value, e.g. below the MOSFET  $BV_{\text{dss}}$  which is 700 V. Figures 26A, B, and C present possible implementations:

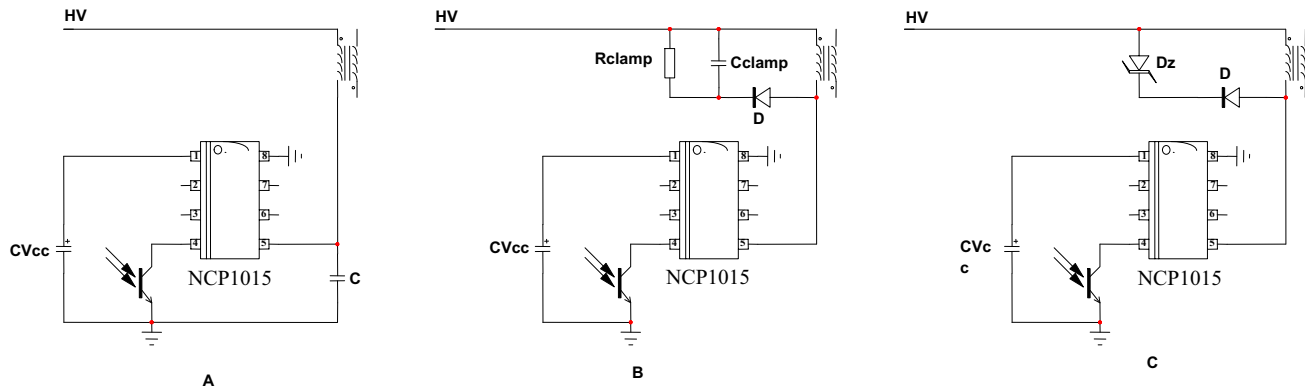

**Figure 26. Different Options to Clamp the Leakage Spike**

Figure 26A: The simple capacitor limits the voltage according to Equation 15. This option is only valid for low power applications, e.g. below 5 W, otherwise chances exist to destroy the MOSFET. After evaluating the leakage inductance, you can compute C with Equation 15. Typical values are between 100 pF and up to 470 pF. Large capacitors increase capacitive losses.

Figure 26B: The most standard circuitry called the RCD network. You calculate  $R_{\text{clamp}}$  and  $C_{\text{clamp}}$  using the following formulas:

$$R_{\text{clamp}} = \frac{2 \cdot V_{\text{clamp}} \cdot (V_{\text{clamp}} - (V_{\text{out}} + V_{\text{f sec}}) \cdot N)}{L_{\text{leak}} \cdot I_{\text{p}}^2 \cdot f_{\text{sw}}} \quad (\text{eq. 27})$$

$$C_{\text{clamp}} = \frac{V_{\text{clamp}}}{V_{\text{ripple}} \cdot f_{\text{sw}} \cdot R_{\text{clamp}}} \quad (\text{eq. 28})$$

$V_{\text{clamp}}$  is usually selected 50–80 V above the reflected value  $N \times (V_{\text{out}} + V_{\text{f}})$ . The diode needs to be a fast one and a MUR160 represents a good choice. One major drawback of the RCD network lies in its dependency upon the peak

current. Worse case occurs when  $I_{\text{p}}$  and  $V_{\text{in}}$  are maximum and  $V_{\text{out}}$  is close to reach the steady-state value.

Figure 26C: This option is probably the most expensive of all three but it offers the best protection degree. If you need a very precise clamping level, you must implement a zener diode or a TVS. There are little technology differences behind a standard zener diode and a TVS. However, the die area is far bigger for a transient suppressor than that of zener. A 5 W zener diode like the 1N5388B will accept 180 W peak power if it lasts less than 8.3 ms. If the peak current in the worse case (e.g. when the PWM circuit maximum current limit works) multiplied by the nominal zener voltage exceeds these 180 W, then the diode will be destroyed when the supply experiences overloads. A transient suppressor like the P6KE200 still dissipates 5 W of continuous power but is able to accept surges up to 600 W @ 1 ms. Select the zener or TVS clamping level between 40 to 80 volts above the reflected output voltage when the supply is heavily loaded.

# NCP1015

## Typical Application Examples

A 6.5 W NCP1015-based Flyback converter. (For evaluation a universal NCP1012 demo-board can be used)

Figure 27 shows a converter originally built with a NCP1012 which can be easily used for evaluation of NCP1015 device delivering 6.5 W from a universal volts

input range. The board uses the Dynamic Self-Supply and a simplified zener-type feedback. This configuration was selected for cost reasons and a more precise circuitry can be used, e.g. based on a TL431:

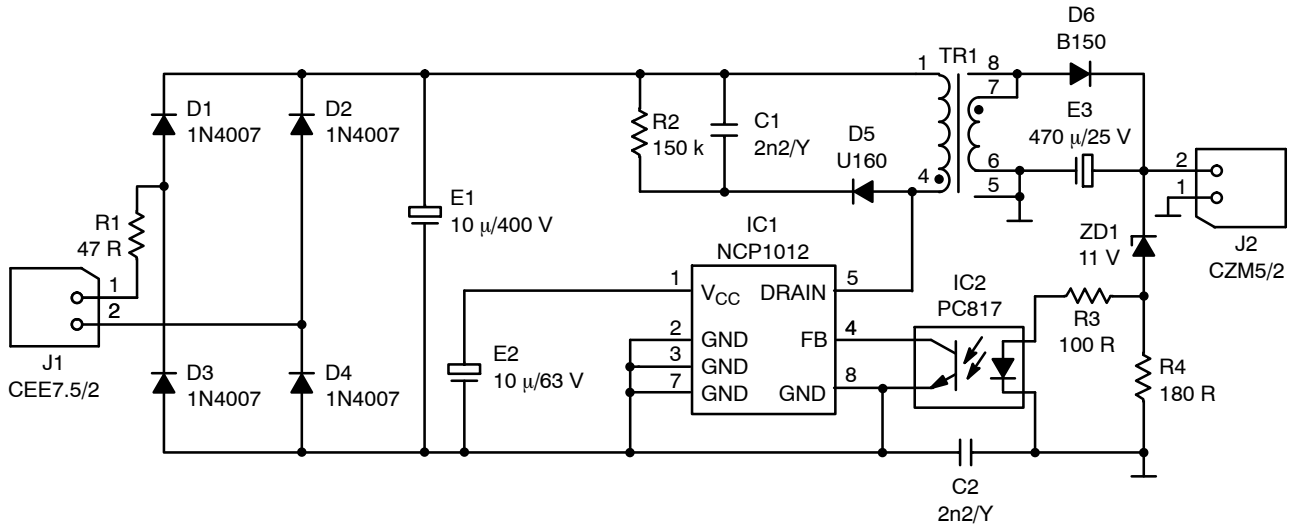

Figure 27. A NCP1012-based Flyback Converter Delivering 6.5 W

The converter built according to Figure 28 layouts, gave the following results:

- Efficiency at  $V_{in} = 100 \text{ Vac}$  and  $P_{out} = 6.5 \text{ W} = 75.7\%$
- Efficiency at  $V_{in} = 230 \text{ Vac}$  and  $P_{out} = 6.5 \text{ W} = 76.5\%$

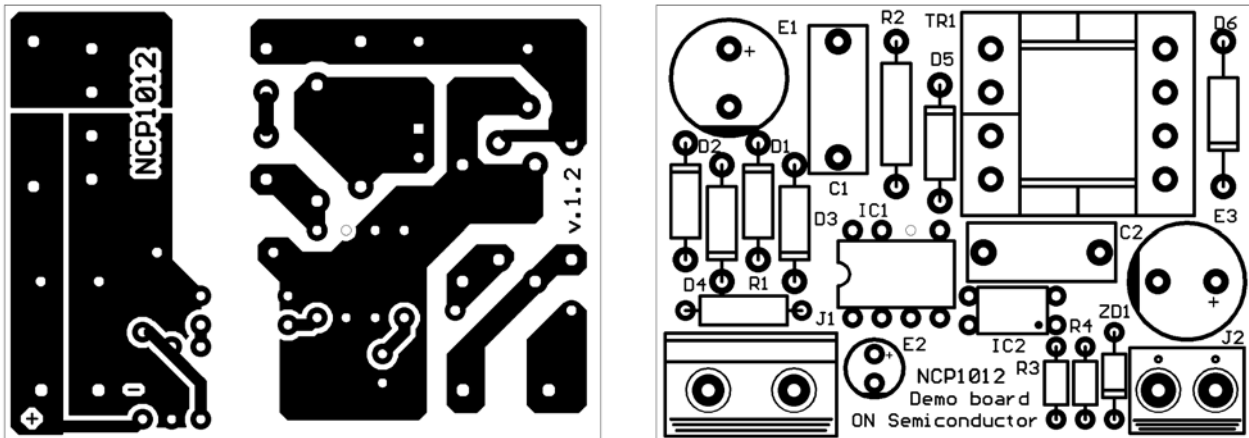

Figure 28. The NCP1012-based PCB Layout and its Associated Component Placement

## NCP1015

### A 7.0 W NCP1015-based Flyback Converter Featuring Low Standby Power

Figure 29 shows another typical application showing a NCP1015–65 kHz operating in a 7 W converter up to 70°C of ambient temperature. We can grow-up the output power since an auxiliary winding is used, the DSS is disabled, and

thus offering more room for the MOSFET. In this application, the feedback is made via a TLV431 whose low bias current (100  $\mu$ A min) helps to lower the no-load standby power.

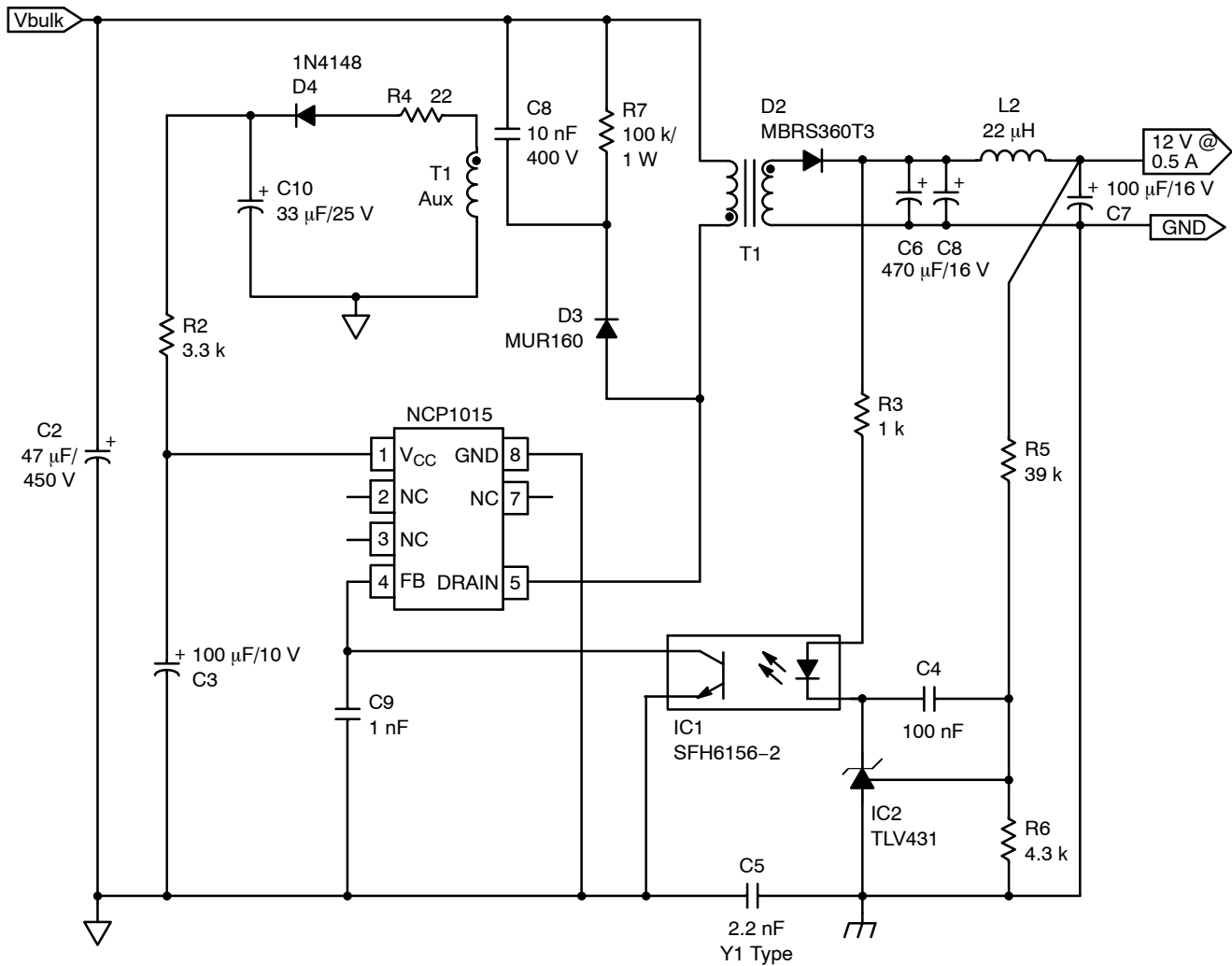

Figure 29. A Typical Converter Delivering 5 W from a Universal Mains

Measurements have been taken from a demonstration board implementing Figure 12's sketch and the following results were achieved, with either the auxiliary winding in place or through the Dynamic Self-Supply:

$V_{in} = 230$  Vac, auxiliary winding,  $P_{out} = 0$ ,  $P_{in} = 60$  mW

$V_{in} = 100$  Vac, auxiliary winding,  $P_{out} = 0$ ,  $P_{in} = 42$  mW

$V_{in} = 230$  Vac, Dynamic Self-Supply,  $P_{out} = 0$ ,  $P_{in} = 300$  mW

$V_{in} = 100$  Vac, Dynamic Self-Supply,  $P_{out} = 0$ ,  $P_{in} = 130$  mW

$P_{out} = 7$  W,  $\eta = 81\%$  @ 230 Vac, with aux winding

$P_{out} = 7$  W,  $\eta = 81.3\%$  @ 100 Vac, with aux winding

For a quick evaluation of Figure 29 application example, the following transformers are available from Coilcraft:

A9619–C,  $L_p = 3$  mH,  $N_p : N_s = 1 : 0.1$ , 7 W application on universal mains, including auxiliary winding, NCP1015–65 kHz

A0032–A,  $L_p = 6$  mH,  $N_p : N_s = 1 : 0.055$ , 10 W application on European mains, DSS operation only, NCP1015–65 kHz

Coilcraft  
1102 Silver Lake Road  
CARY, IL 60013  
Email: [info@coilcraft.com](mailto:info@coilcraft.com)  
Tel. : 847–639–6400  
Fax.: 847–639–1469

# NCP1015

## ORDERING INFORMATION

Device Order Number	Frequency (kHz)	Package Type	Shipping <sup>†</sup>	R <sub>DSon</sub> (Ω)	I <sub>pk</sub> (mA)
NCP1015AP065G	65	PDIP-7 (Pb-Free)	50 Units / Rail	11	450
NCP1015AP100G	100	PDIP-7 (Pb-Free)		11	450
NCP1015ST65T3G	65	SOT-223 (Pb-Free)	4000 / Tape & Reel	11	450
NCP1015ST100T3G	100	SOT-223 (Pb-Free)		11	450

<sup>†</sup>For information on tape and reel specifications, including part orientation and tape sizes, please refer to our Tape and Reel Packaging Specifications Brochure, BRD8011/D.

# MECHANICAL CASE OUTLINE

## PACKAGE DIMENSIONS

ON Semiconductor®



SCALE 1:1

SOT-223 (TO-261)  
CASE 318E-04  
ISSUE R

DATE 02 OCT 2018

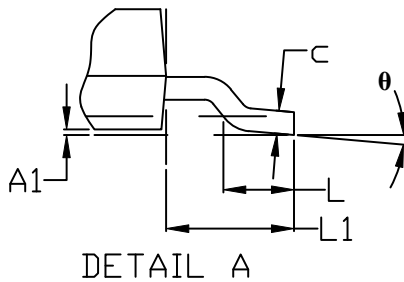
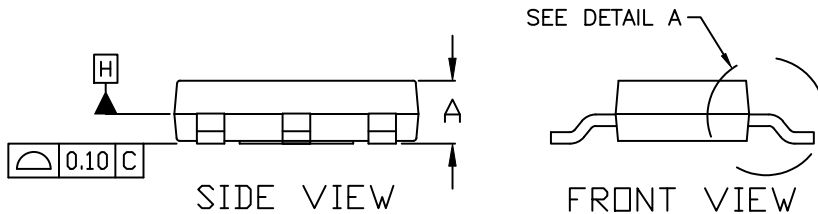

NOTES:

1. DIMENSIONING AND TOLERANCING PER ASME Y14.5M, 1994.
2. CONTROLLING DIMENSION: MILLIMETERS
3. DIMENSIONS D & E DO NOT INCLUDE MOLD FLASH, PROTRUSIONS OR GATE BURRS. MOLD FLASH, PROTRUSIONS OR GATE BURRS SHALL NOT EXCEED 0.200MM PER SIDE.
4. DATUMS A AND B ARE DETERMINED AT DATUM H.
5. A1 IS DEFINED AS THE VERTICAL DISTANCE FROM THE SEATING PLANE TO THE LOWEST POINT OF THE PACKAGE BODY.
6. POSITIONAL TOLERANCE APPLIES TO DIMENSIONS b AND b1.

MILLIMETERS			
DIM	MIN.	NOM.	MAX.
A	1.50	1.63	1.75
A1	0.02	0.06	0.10
b	0.60	0.75	0.89
b1	2.90	3.06	3.20
c	0.24	0.29	0.35
D	6.30	6.50	6.70
E	3.30	3.50	3.70
e	2.30 BSC		
L	0.20	---	---
L1	1.50	1.75	2.00
He	6.70	7.00	7.30
θ	0°	---	10°

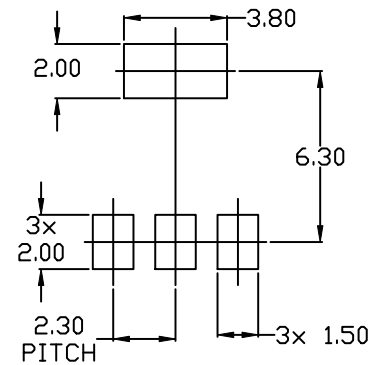

DOCUMENT NUMBER:	98ASB42680B	Electronic versions are uncontrolled except when accessed directly from the Document Repository. Printed versions are uncontrolled except when stamped "CONTROLLED COPY" in red.
DESCRIPTION:	SOT-223 (TO-261)	PAGE 1 OF 2

ON Semiconductor and are trademarks of Semiconductor Components Industries, LLC dba ON Semiconductor or its subsidiaries in the United States and/or other countries. ON Semiconductor reserves the right to make changes without further notice to any products herein. ON Semiconductor makes no warranty, representation or guarantee regarding the suitability of its products for any particular purpose, nor does ON Semiconductor assume any liability arising out of the application or use of any product or circuit, and specifically disclaims any and all liability, including without limitation special, consequential or incidental damages. ON Semiconductor does not convey any license under its patent rights nor the rights of others.

**SOT-223 (TO-261)**  
**CASE 318E-04**  
**ISSUE R**

DATE 02 OCT 2018

- |  |   |   |   |   |
|--|---|---|---|---|
| <b>STYLE 1:</b><br>PIN 1. BASE<br>2. COLLECTOR<br>3. EMITTER<br>4. COLLECTOR | <b>STYLE 2:</b><br>PIN 1. ANODE<br>2. CATHODE<br>3. NC<br>4. CATHODE        | <b>STYLE 3:</b><br>PIN 1. GATE<br>2. DRAIN<br>3. SOURCE<br>4. DRAIN           | <b>STYLE 4:</b><br>PIN 1. SOURCE<br>2. DRAIN<br>3. GATE<br>4. DRAIN   | <b>STYLE 5:</b><br>PIN 1. DRAIN<br>2. GATE<br>3. SOURCE<br>4. GATE    |
| <b>STYLE 6:</b><br>PIN 1. RETURN<br>2. INPUT<br>3. OUTPUT<br>4. INPUT        | <b>STYLE 7:</b><br>PIN 1. ANODE 1<br>2. CATHODE<br>3. ANODE 2<br>4. CATHODE | <b>STYLE 8:</b><br>CANCELLED  | <b>STYLE 9:</b><br>PIN 1. INPUT<br>2. GROUND<br>3. LOGIC<br>4. GROUND | <b>STYLE 10:</b><br>PIN 1. CATHODE<br>2. ANODE<br>3. GATE<br>4. ANODE |
| <b>STYLE 11:</b><br>PIN 1. MT 1<br>2. MT 2<br>3. GATE<br>4. MT 2             | <b>STYLE 12:</b><br>PIN 1. INPUT<br>2. OUTPUT<br>3. NC<br>4. OUTPUT         | <b>STYLE 13:</b><br>PIN 1. GATE<br>2. COLLECTOR<br>3. EMITTER<br>4. COLLECTOR |   |   |

**GENERIC  
 MARKING DIAGRAM\***



- A = Assembly Location
- Y = Year
- W = Work Week
- XXXXX = Specific Device Code
- = Pb-Free Package

(Note: Microdot may be in either location)

\*This information is generic. Please refer to device data sheet for actual part marking. Pb-Free indicator, "G" or microdot "▪", may or may not be present. Some products may not follow the Generic Marking.

<b>DOCUMENT NUMBER:</b>	<b>98ASB42680B</b>	Electronic versions are uncontrolled except when accessed directly from the Document Repository. Printed versions are uncontrolled except when stamped "CONTROLLED COPY" in red.
<b>DESCRIPTION:</b>	<b>SOT-223 (TO-261)</b>	<b>PAGE 2 OF 2</b>

ON Semiconductor and are trademarks of Semiconductor Components Industries, LLC dba ON Semiconductor or its subsidiaries in the United States and/or other countries. ON Semiconductor reserves the right to make changes without further notice to any products herein. ON Semiconductor makes no warranty, representation or guarantee regarding the suitability of its products for any particular purpose, nor does ON Semiconductor assume any liability arising out of the application or use of any product or circuit, and specifically disclaims any and all liability, including without limitation special, consequential or incidental damages. ON Semiconductor does not convey any license under its patent rights nor the rights of others.

# MECHANICAL CASE OUTLINE

## PACKAGE DIMENSIONS

ON Semiconductor®



### PDIP-7 (PDIP-8 LESS PIN 6) CASE 626A ISSUE C

DATE 22 APR 2015

SCALE 1:1

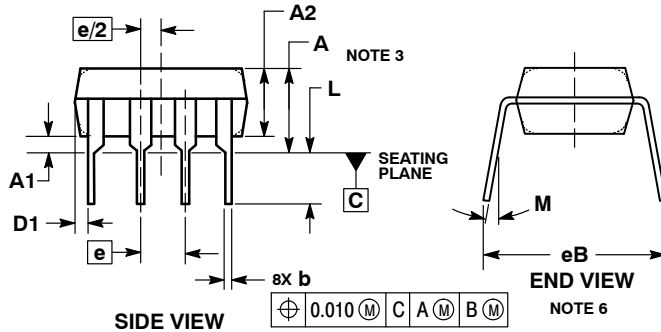
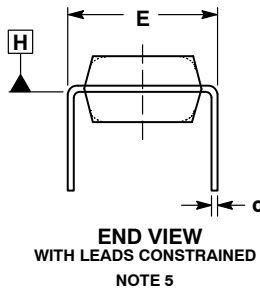
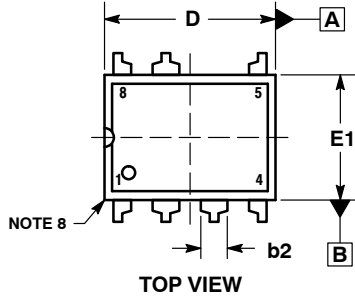

**NOTES:**

1. DIMENSIONING AND TOLERANCING PER ASME Y14.5M, 1994.
2. CONTROLLING DIMENSION: INCHES.
3. DIMENSIONS A, A1 AND L ARE MEASURED WITH THE PACKAGE SEATED IN JEDEC SEATING PLANE GAUGE GS-3.
4. DIMENSIONS D, D1 AND E1 DO NOT INCLUDE MOLD FLASH OR PROTRUSIONS. MOLD FLASH OR PROTRUSIONS ARE NOT TO EXCEED 0.10 INCH.
5. DIMENSION E IS MEASURED AT A POINT 0.015 BELOW DATUM PLANE H WITH THE LEADS CONSTRAINED PERPENDICULAR TO DATUM C.
6. DIMENSION eB IS MEASURED AT THE LEAD TIPS WITH THE LEADS UNCONSTRAINED.
7. DATUM PLANE H IS COINCIDENT WITH THE BOTTOM OF THE LEADS, WHERE THE LEADS EXIT THE BODY.
8. PACKAGE CONTOUR IS OPTIONAL (ROUNDED OR SQUARE CORNERS).

DIM	INCHES		MILLIMETERS	
	MIN	MAX	MIN	MAX
A	----	0.210	----	5.33
A1	0.015	----	0.38	----
A2	0.115	0.195	2.92	4.95
b	0.014	0.022	0.35	0.56
b2	0.060 TYP		1.52 TYP	
C	0.008	0.014	0.20	0.36
D	0.355	0.400	9.02	10.16
D1	0.005	----	0.13	----
E	0.300	0.325	7.62	8.26
E1	0.240	0.280	6.10	7.11
e	0.100 BSC		2.54 BSC	
eB	----	0.430	----	10.92
L	0.115	0.150	2.92	3.81
M	----	10°	----	10°

### GENERIC MARKING DIAGRAM\*

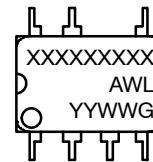

- XXXX = Specific Device Code
- A = Assembly Location
- WL = Wafer Lot
- YY = Year
- WW = Work Week
- G = Pb-Free Package

\*This information is generic. Please refer to device data sheet for actual part marking. Pb-Free indicator, "G" or microdot "▪", may or may not be present.

<b>DOCUMENT NUMBER:</b>	<b>98AON11774D</b>	Electronic versions are uncontrolled except when accessed directly from the Document Repository. Printed versions are uncontrolled except when stamped "CONTROLLED COPY" in red.
<b>DESCRIPTION:</b>	<b>PDIP-7 (PDIP-8 LESS PIN 6)</b>	<b>PAGE 1 OF 1</b>

ON Semiconductor and are trademarks of Semiconductor Components Industries, LLC dba ON Semiconductor or its subsidiaries in the United States and/or other countries. ON Semiconductor reserves the right to make changes without further notice to any products herein. ON Semiconductor makes no warranty, representation or guarantee regarding the suitability of its products for any particular purpose, nor does ON Semiconductor assume any liability arising out of the application or use of any product or circuit, and specifically disclaims any and all liability, including without limitation special, consequential or incidental damages. ON Semiconductor does not convey any license under its patent rights nor the rights of others.

ON Semiconductor and  are trademarks of Semiconductor Components Industries, LLC dba ON Semiconductor or its subsidiaries in the United States and/or other countries. ON Semiconductor owns the rights to a number of patents, trademarks, copyrights, trade secrets, and other intellectual property. A listing of ON Semiconductor's product/patent coverage may be accessed at [www.onsemi.com/site/pdf/Patent-Marking.pdf](http://www.onsemi.com/site/pdf/Patent-Marking.pdf). ON Semiconductor reserves the right to make changes without further notice to any products herein. ON Semiconductor makes no warranty, representation or guarantee regarding the suitability of its products for any particular purpose, nor does ON Semiconductor assume any liability arising out of the application or use of any product or circuit, and specifically disclaims any and all liability, including without limitation special, consequential or incidental damages. Buyer is responsible for its products and applications using ON Semiconductor products, including compliance with all laws, regulations and safety requirements or standards, regardless of any support or applications information provided by ON Semiconductor. "Typical" parameters which may be provided in ON Semiconductor data sheets and/or specifications can and do vary in different applications and actual performance may vary over time. All operating parameters, including "Typicals" must be validated for each customer application by customer's technical experts. ON Semiconductor does not convey any license under its patent rights nor the rights of others. ON Semiconductor products are not designed, intended, or authorized for use as a critical component in life support systems or any FDA Class 3 medical devices or medical devices with a same or similar classification in a foreign jurisdiction or any devices intended for implantation in the human body. Should Buyer purchase or use ON Semiconductor products for any such unintended or unauthorized application, Buyer shall indemnify and hold ON Semiconductor and its officers, employees, subsidiaries, affiliates, and distributors harmless against all claims, costs, damages, and expenses, and reasonable attorney fees arising out of, directly or indirectly, any claim of personal injury or death associated with such unintended or unauthorized use, even if such claim alleges that ON Semiconductor was negligent regarding the design or manufacture of the part. ON Semiconductor is an Equal Opportunity/Affirmative Action Employer. This literature is subject to all applicable copyright laws and is not for resale in any manner.

## PUBLICATION ORDERING INFORMATION

### LITERATURE FULFILLMENT:

Email Requests to: [orderlit@onsemi.com](mailto:orderlit@onsemi.com)

ON Semiconductor Website: [www.onsemi.com](http://www.onsemi.com)

### TECHNICAL SUPPORT

North American Technical Support:  
Voice Mail: 1 800-282-9855 Toll Free USA/Canada  
Phone: 011 421 33 790 2910

### Europe, Middle East and Africa Technical Support:

Phone: 00421 33 790 2910

For additional information, please contact your local Sales Representative