



ON Semiconductor®

FDG8842CZ

Complementary PowerTrench® MOSFET

Q1: 30V, 0.75A, 0.4Ω; Q2: -25V, -0.41A, 1.1Ω

Features

Q1: N-Channel

- Max $r_{DS(on)}$ = 0.4Ω at $V_{GS} = 4.5V$, $I_D = 0.75A$
- Max $r_{DS(on)}$ = 0.5Ω at $V_{GS} = 2.7V$, $I_D = 0.67A$

Q2: P-Channel

- Max $r_{DS(on)}$ = 1.1Ω at $V_{GS} = -4.5V$, $I_D = -0.41A$
- Max $r_{DS(on)}$ = 1.5Ω at $V_{GS} = -2.7V$, $I_D = -0.25A$
- Very low level gate drive requirements allowing direct operation in 3V circuits ($V_{GS(th)} < 1.5V$)
- Very small package outline SC70-6
- RoHS Compliant

General Description

These N & P-Channel logic level enhanced mode field effect transistors are produced using ON Semiconductor's proprietary, high cell density CMOS technology. This very high density process is especially tailored to minimize on-state resistance. The device has been designed especially for low voltage applications as a replacement for bipolar digital transistors and small signal MOSFETs. Since bias resistors are not required, this dual digital FET can replace conventional digital transistors, with different bias resistor values.

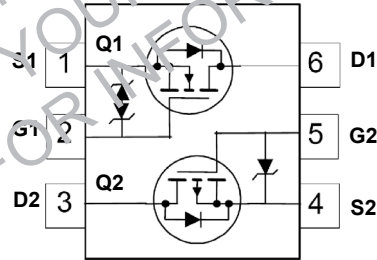
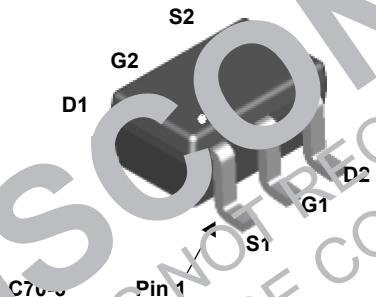

MOSFET Maximum Ratings $T_J = 25^\circ C$ unless otherwise noted

Symbol	Parameter	Q1	Q2	Units
V_{DS}	Drain to Source Voltage	30	-25	V
V_{GS}	Gate to Source Voltage	±12	-8	V
I_D	Drain Current -Continuous	0.75	-0.41	A
	-Pulsed	2.2	-1.2	
P_D	Power Dissipation for Single Operation (Note 1a) (Note 1b)	0.36		W
		0.30		
T_J, T_{STG}	Operating and Storage Junction Temperature Range	-55 to +150		°C

Thermal Characteristics

$R_{\theta JA}$	Thermal Resistance, Junction to Ambient Single operation (Note 1a)	350	°C/W
$R_{\theta JA}$	Thermal Resistance, Junction to Ambient Single operation (Note 1b)	415	

Package Marking and Ordering Information

Device Marking	Device	Reel Size	Tape Width	Quantity
.42	FDG8842CZ	7"	8mm	3000 units

Electrical Characteristics $T_J = 25^\circ\text{C}$ unless otherwise noted

Symbol	Parameter	Test Conditions	Type	Min	Typ	Max	Units
--------	-----------	-----------------	------	-----	-----	-----	-------

Off Characteristics

BV_{DSS}	Drain to Source Breakdown Voltage	$I_D = 250\mu\text{A}, V_{GS} = 0\text{V}$ $I_D = -250\mu\text{A}, V_{GS} = 0\text{V}$	Q1 Q2	30 -25			V
$\frac{\Delta BV_{DSS}}{\Delta T_J}$	Breakdown Voltage Temperature Coefficient	$I_D = 250\mu\text{A}$, referenced to 25°C $I_D = -250\mu\text{A}$, referenced to 25°C	Q1 Q2		25 -21		mV/ $^\circ\text{C}$
I_{DSS}	Zero Gate Voltage Drain Current	$V_{DS} = 24\text{V}, V_{GS} = 0\text{V}$ $V_{DS} = -20\text{V}, V_{GS} = 0\text{V}$	Q1 Q2			1 -1	μA
I_{GSS}	Gate to Source Leakage Current	$V_{GS} = \pm 12\text{V}, V_{DS} = 0\text{V}$ $V_{GS} = -8\text{V}, V_{DS} = 0\text{V}$	Q1 Q2			± 10 -100	μA nA

On Characteristics

$V_{GS(th)}$	Gate to Source Threshold Voltage	$V_{GS} = V_{DS}, I_D = 250\mu\text{A}$ $V_{GS} = V_{DS}, I_D = -250\mu\text{A}$	Q1 Q2	0.35 -0.65	1.0 0.8	1.5 1.5	V
$\frac{\Delta V_{GS(th)}}{\Delta T_J}$	Gate to Source Threshold Voltage Temperature Coefficient	$I_D = 250\mu\text{A}$, referenced to 25°C $I_D = -250\mu\text{A}$, referenced to 25°C	Q1 Q2		-3 1.8		mV/ $^\circ\text{C}$
$r_{DS(on)}$	Static Drain to Source On Resistance	$V_{GS} = 4.5\text{V}, I_D = 0.75\text{A}$ $V_{GS} = 2.7\text{V}, I_D = 0.67\text{A}$ $V_{GS} = 4.5\text{V}, I_D = 0.75\text{A}, T_J = 125^\circ\text{C}$ $V_{GS} = -4.5\text{V}, I_D = -0.41\text{A}$ $V_{GS} = -2.7\text{V}, I_D = -0.25\text{A}$ $V_{GS} = -4.5\text{V}, I_D = -0.41\text{A}, T_J = 125^\circ\text{C}$	Q Q2		0.25 0.29 0.36 0.87 1.20 1.22	0.4 0.5 0.6 1.1 1.5 1.9	Ω
g_{FS}	Forward Transconductance	$V_{DS} = 5\text{V}, I_D = 0.75\text{A}$ $V_{DS} = -5\text{V}, I_D = -0.41\text{A}$	Q1 Q2		3 8		S

Dynamic Characteristics

C_{iss}	Input Capacitance	$V_{DS} = 10\text{V}, V_{GS} = 0\text{V}, f = 1\text{MHz}$	Q1 Q2		90 70	120 100	pF
C_{oss}	Output Capacitance	$V_{DS} = -10\text{V}, V_{GS} = 0\text{V}, f = 1\text{MHz}$	Q1 Q2		20 30	30 40	pF
C_{rss}	Reverse Transfer Capacitance		Q1 Q2		15 15	25 25	pF

Switching Characteristics (note 2)

t_{on}	Turn-On Delay Time	$V_{DD} = 5\text{V}, I_D = 0.5\text{A}, V_{GS} = 4.5\text{V}, R_{GEN} = 6\Omega$	Q1 Q2		4 6	10 12	ns
t_r	Rise Time	$V_{DD} = 5\text{V}, I_D = 0.5\text{A}, V_{GS} = 4.5\text{V}, R_{GEN} = 6\Omega$	Q1 Q2		1 16	10 29	ns
$t_{d(off)}$	Turn-Off Delay Time	$V_{DD} = -5\text{V}, I_D = -0.5\text{A}, V_{GS} = -4.5\text{V}, R_{GEN} = 6\Omega$	Q1 Q2		9 35	18 56	ns
t_f	Fall Time	$V_{DD} = -5\text{V}, I_D = -0.5\text{A}, V_{GS} = -4.5\text{V}, R_{GEN} = 6\Omega$	Q1 Q2		1 40	10 64	ns
Q_g	Total Gate Charge		Q1 Q2		1.03 1.20	1.44 1.68	nC
Q_{gs}	Gate to Source Charge	$V_{GS} = 4.5\text{V}, V_{DD} = 5\text{V}, I_D = 0.75\text{A}$	Q1 Q2		0.29 0.31		nC
Q_{gd}	Gate to Drain "Miller" Charge	$V_{GS} = -4.5\text{V}, V_{DD} = -5\text{V}, I_D = -0.41\text{A}$	Q1 Q2		0.17 0.22		nC

Electrical Characteristics $T_J = 25^\circ\text{C}$ unless otherwise noted

Symbol	Parameter	Test Conditions	Type	Min	Typ	Max	Units
--------	-----------	-----------------	------	-----	-----	-----	-------

Drain-Source Diode Characteristics and Maximum Ratings

I_S	Maximum Continuous Drain-Source Diode Forward Current		Q1 Q2			0.3 -0.3	A
V_{SD}	Source to Drain Diode Forward Voltage	$V_{GS} = 0V, I_S = 0.3A$ (Note 2) $V_{GS} = 0V, I_S = -0.3A$ (Note 2)	Q1 Q2		0.76 -0.84	1.2 -1.2	V

Notes:

- $R_{\theta JA}$ is the sum of the junction-to-case and case-to-ambient thermal resistance where the case thermal reference is defined as the solder mounting surface of the drain pins. $R_{\theta JC}$ is guaranteed by design while $R_{\theta JA}$ is determined by the user's board design.



Scale 1:1 on letter size paper.

a. 350°C/W when mounted on a 1 in^2 pad of 2 oz copper.

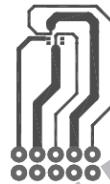

b. 415°C/W when mounted on a minimum pad of 2 oz copper.

- Pulse Test: Pulse Width $< 300\mu\text{s}$, Duty cycle $< 2.0\%$.

DISCONTINUED

THIS DEVICE IS NOT RECOMMENDED FOR NEW DESIGN

PLEASE CONTACT YOUR onsemi REPRESENTATIVE FOR INFORMATION

Typical Characteristics (Q1 N-Channel) $T_J = 25^\circ\text{C}$ unless otherwise noted

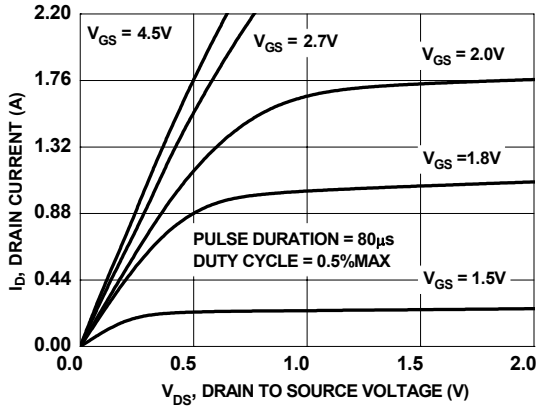

Figure 1. On-Region Characteristics

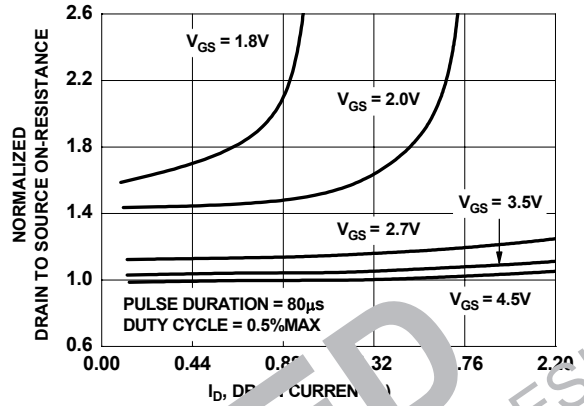

Figure 2. Normalized On-Resistance vs. Drain Current and Gate Voltage

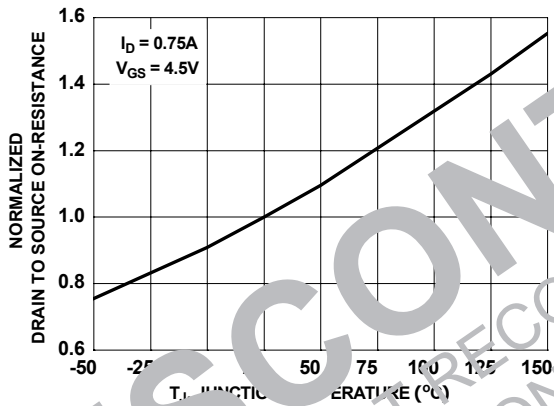

Figure 3. Normalized On-Resistance vs. Junction Temperature

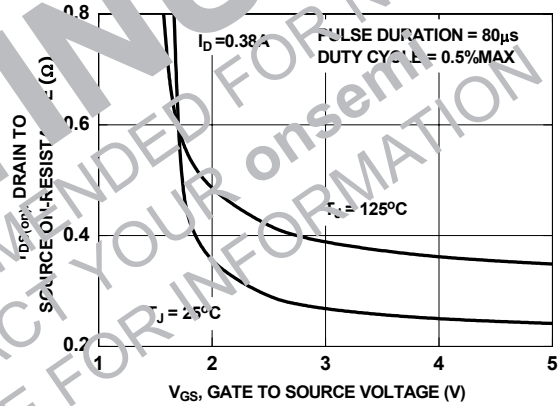

Figure 4. On-Resistance vs. Gate to Source Voltage

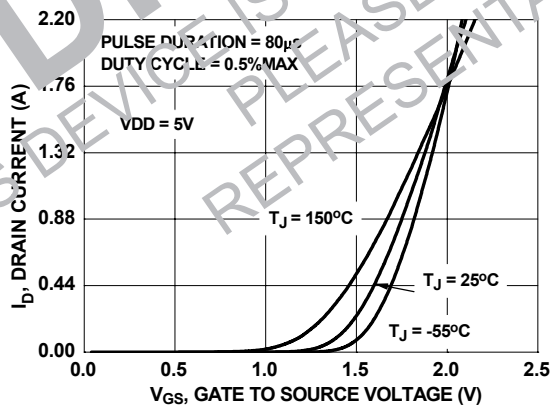

Figure 5. Transfer Characteristics

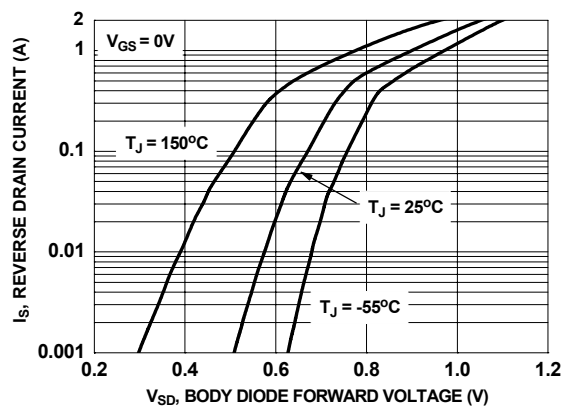

Figure 6. Source to Drain Diode Forward Voltage vs. Source Current

Typical Characteristics (Q1 N-Channel) $T_J = 25^\circ\text{C}$ unless otherwise noted

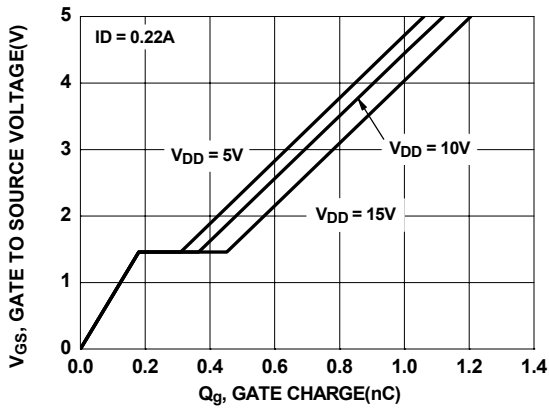

Figure 7. Gate Charge Characteristics

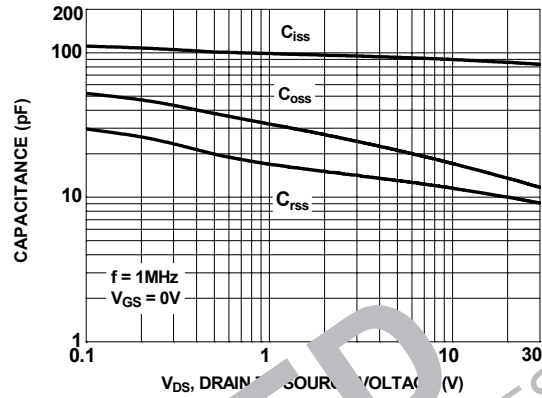

Figure 8. Capacitance vs Drain to Source Voltage

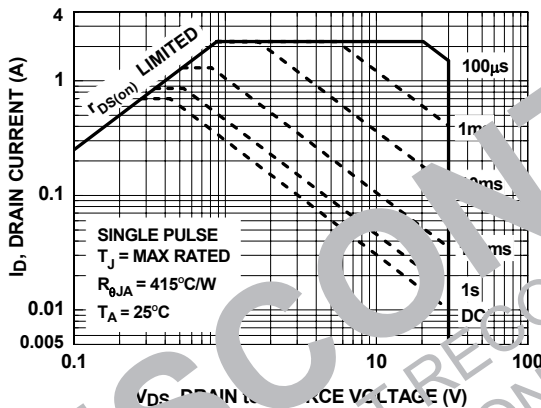

Figure 9. Forward Bias Safe Operating Area

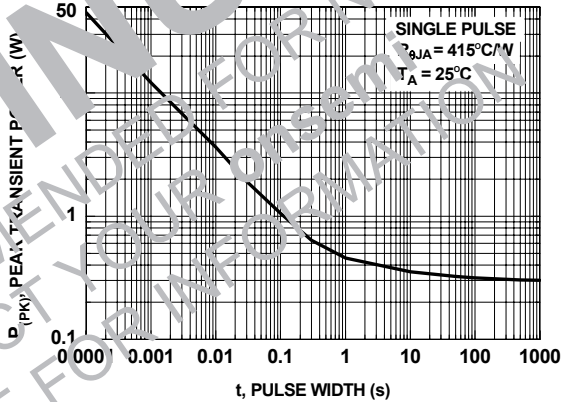

Figure 10. Single Pulse Maximum Power Dissipation

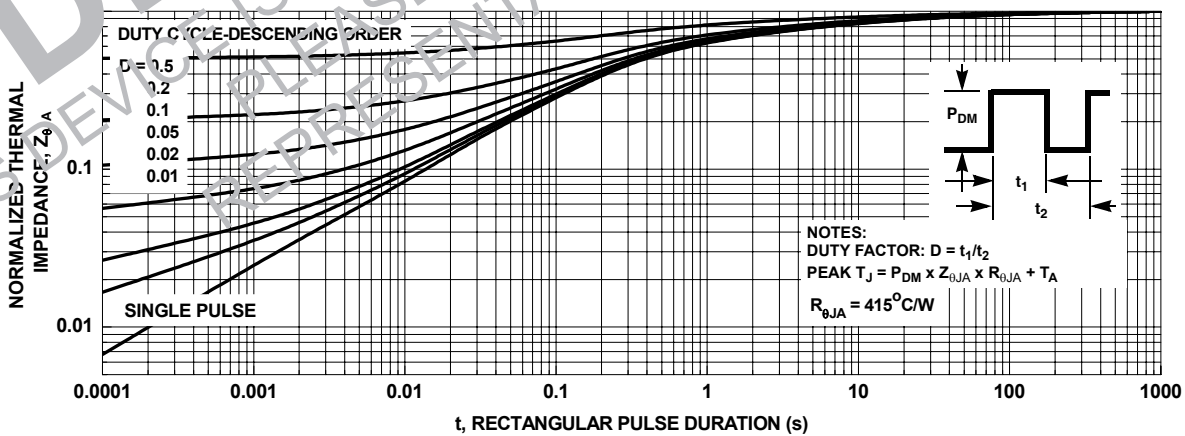

Figure 11. Transient Thermal Response Curve

Typical Characteristics (Q2 P-Channel) $T_J = 25^\circ\text{C}$ unless otherwise noted

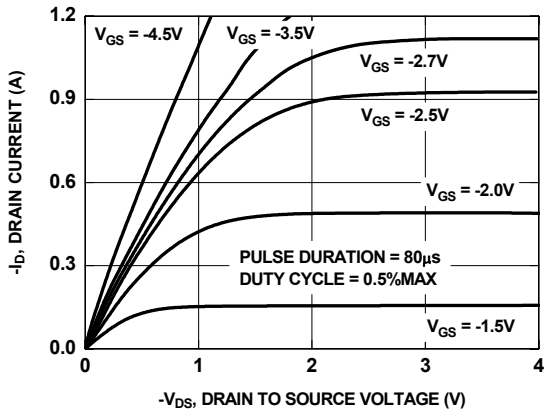

Figure 13. On Region Characteristics

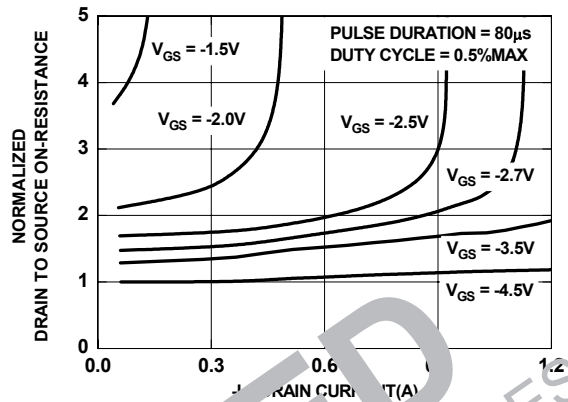

Figure 14. Normalized On-Resistance vs Drain Current and Gate Voltage

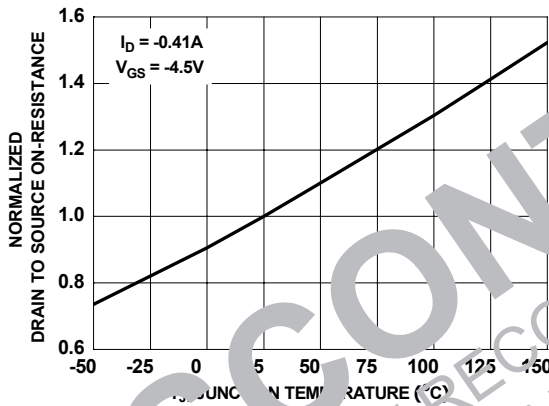

Figure 15. Normalized On Resistance vs Junction Temperature

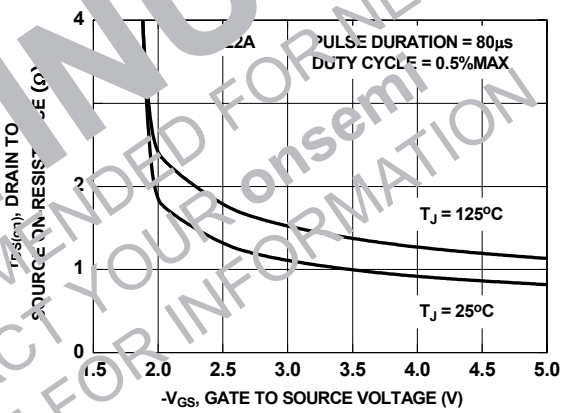

Figure 16. On-Resistance vs Gate to Source Voltage

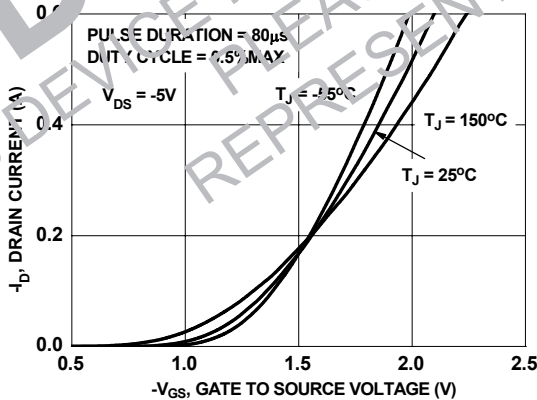

Figure 17. Transfer Characteristics

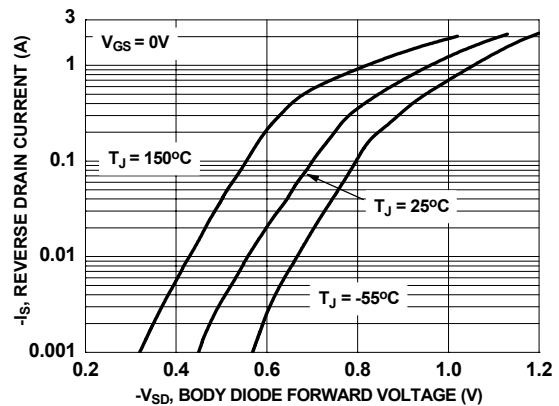

Figure 18. Source to Drain Diode Forward Voltage vs Source Current

Typical Characteristics(Q2 P-Channel) $T_J = 25^\circ\text{C}$ unless otherwise noted

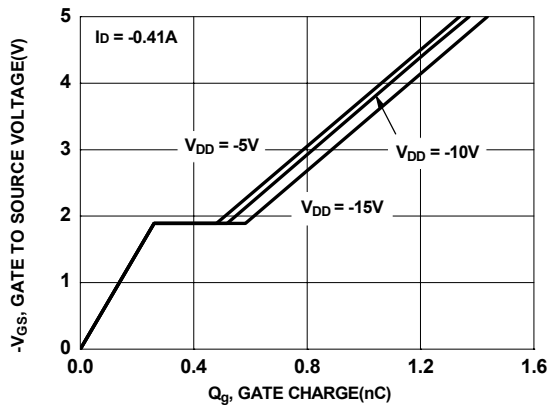

Figure 19. Gate Charge Characteristics

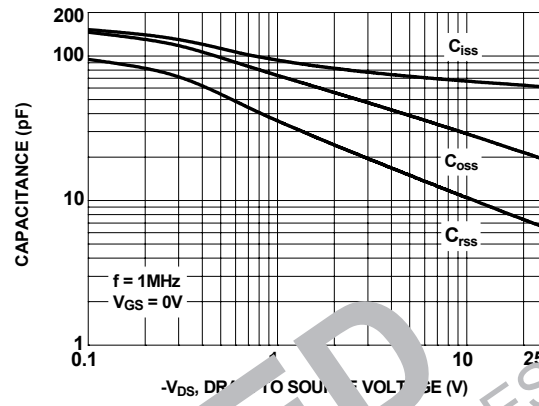

Figure 20. Capacitance vs Drain to Source Voltage

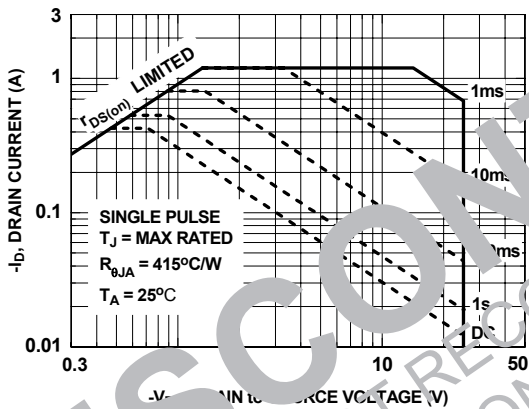

Figure 21. Forward Bias Safe Operating Area

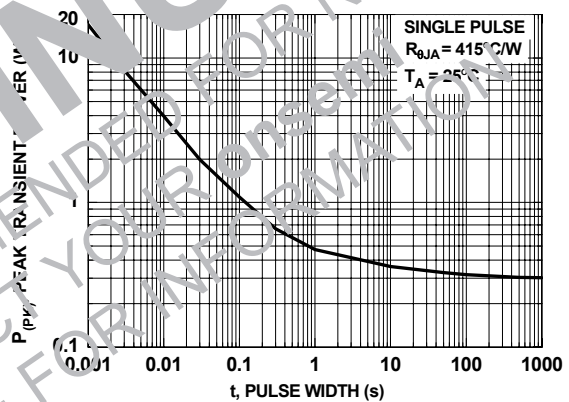

Figure 22. Single Pulse Maximum Power Dissipation

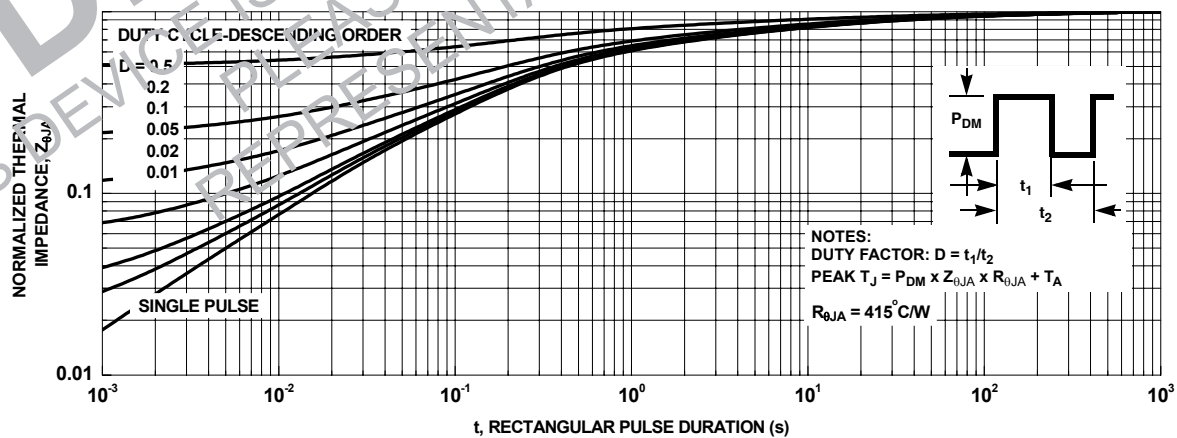



Figure 23. Transient Thermal Response Curve

DISCONTINUED

THIS DEVICE IS NOT RECOMMENDED FOR NEW DESIGN
PLEASE CONTACT YOUR onsemi
REPRESENTATIVE FOR INFORMATION

ON Semiconductor and  are trademarks of Semiconductor Components Industries, LLC dba ON Semiconductor or its subsidiaries in the United States and/or other countries. ON Semiconductor owns the rights to a number of patents, trademarks, copyrights, trade secrets, and other intellectual property. A listing of ON Semiconductor's product/patent coverage may be accessed at www.onsemi.com/site/pdf/Patent-Marking.pdf. ON Semiconductor reserves the right to make changes without further notice to any products herein. ON Semiconductor makes no warranty, representation or guarantee regarding the suitability of its products for any particular purpose, nor does ON Semiconductor assume any liability arising out of the application or use of any product or circuit, and specifically disclaims any and all liability, including without limitation special, consequential or incidental damages. Buyer is responsible for its products and applications using ON Semiconductor products, including compliance with all laws, regulations and safety requirements or standards, regardless of any support or applications information provided by ON Semiconductor. "Typical" parameters which may be provided in ON Semiconductor data sheets and/or specifications can and do vary in different applications and actual performance may vary over time. All operating parameters, including "Typicals" must be validated for each customer application by customer's technical experts. ON Semiconductor does not convey any license under its patent rights nor the rights of others. ON Semiconductor products are not designed, intended, or authorized for use as a critical component in life support systems or any FDA Class 3 medical devices or medical devices with a same or similar classification in a foreign jurisdiction or any devices intended for implantation in the human body. Should Buyer purchase or use ON Semiconductor products for any such unintended or unauthorized application, Buyer shall indemnify and hold ON Semiconductor and its officers, employees, subsidiaries, affiliates, and distributors harmless against all claims, costs, damages, and expenses, and reasonable attorney fees arising out of, directly or indirectly, any claim of personal injury or death associated with such unintended or unauthorized use, even if such claim alleges that ON Semiconductor was negligent regarding the design or manufacture of the part. ON Semiconductor is an Equal Opportunity/Affirmative Action Employer. This literature is subject to all applicable copyright laws and is not for resale in any manner.

PUBLICATION ORDERING INFORMATION

LITERATURE FULFILLMENT:

Literature Distribution Center for ON Semiconductor
19521 E. 32nd Pkwy, Aurora, Colorado 80011 USA
Phone: 303-675-2175 or 800-344-3860 Toll Free USA/Canada
Fax: 303-675-2176 or 800-344-3867 Toll Free USA/Canada
Email: orderlit@onsemi.com

N. American Technical Support: 800-282-9855 Toll Free
USA/Canada
Europe, Middle East and Africa Technical Support:
Phone: 421 33 790 2910
Japan Customer Focus Center
Phone: 81-3-5817-1050

ON Semiconductor Website: www.onsemi.com
Order Literature: <http://www.onsemi.com/orderlit>
For additional information, please contact your local
Sales Representative