



ON Semiconductor

28V, 3.3A Off-Line High PF LED Driver

Device	Application	Input Voltage	Output Power	Topology	I/O Isolation
NCL30001 NCS1002	90 Watt CVCC LED Driver with Dimming	90 – 265/305* Vac	90 Watts	Single Stage PFC/Flyback	Yes – 3 kV

- 277 Vac can be supported with a slight BOM change

	Output
Output Voltage	30 Vdc max
Ripple	< 10%
Nominal Current	3.3 Amps
Max Current	3.5 Amps
Min Current	Zero

PFC (Yes/No)	Yes
Typical Efficiency	87%
Inrush Limiting / Fuse	Yes
Operating Temp. Range	0 to 50C
Cooling Method / Supply Orientation	Convection NA
Signal Level Control	Yes – Dimming functions

Overview

This Design Note (DN) is an extension to ON Semiconductor's Application Note AND8427/D and illustrates how the NCL30001 continuous conduction mode power factor corrected single stage flyback controller can be used to implement a constant current LED driver for area lighting applications such as high bay, tunnel, parking garage and roadway lighting

This specific design has been optimized for LEDs that require greater than 3A drive capability such as the Luminus Devices CSM360 and SST90. This design can support up to 8 SST90 devices in series or 2 CSM360. The CSM360 LED has a nominal forward voltage of 12.8 V at a drive current of 3.2A and depending on the color temperature and flux bin can generate 1600-3900 lumens.

Circuit Description

This circuit design illustrates a 3.3A, and up to 28 volt maximum forward voltage configuration

of the off-line, NCL30001 based constant voltage, constant current (CVCC) LED driver.

Since this design has comparable power level to the standard NCL30001 evaluation board (50V up to 2A), the principle circuit changes were in the transformer design and the constant current / constant voltage secondary control circuitry based on the NCS1002. The primary stage is illustrated in Figure 1.

The secondary side control circuitry is illustrated in Figure 2. In this design, the output voltage is determined by a resistor ratio and the output current is also set based on a resistor ratio. As result only two resistors: R34 which is part of the output voltage divider and R32 which is part of the current setting circuit need to be changed. In addition, since the output voltage is lower and the output current is higher, the output capacitance is increased and the voltage rating of the capacitors are reduced.

The flyback transformer for this design was scaled from the secondary winding on the

DN06068/D

original design to meet the new maximum voltage and current requirements. The primary winding, required inductance, and overall construction are essentially the same.

277 Vac input can be utilized with proper voltage rating changes to the EMI input filter "X" and "Y" capacitors.

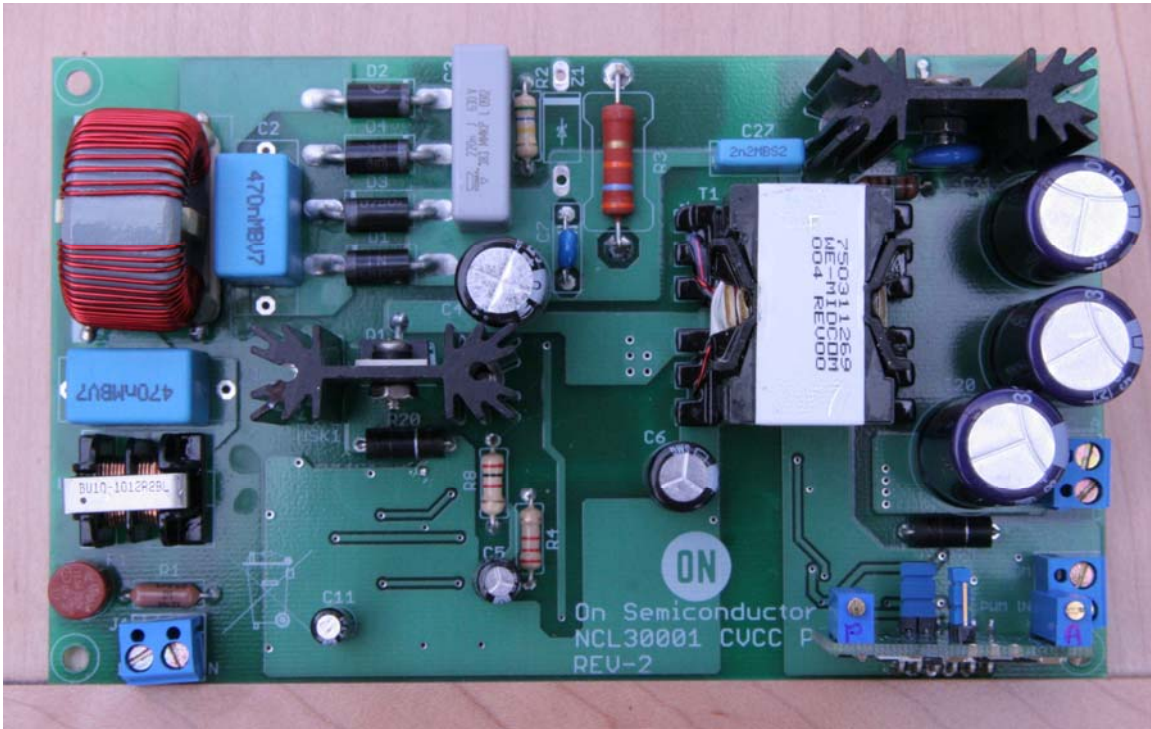

Top Size View of Board

DN06068/D

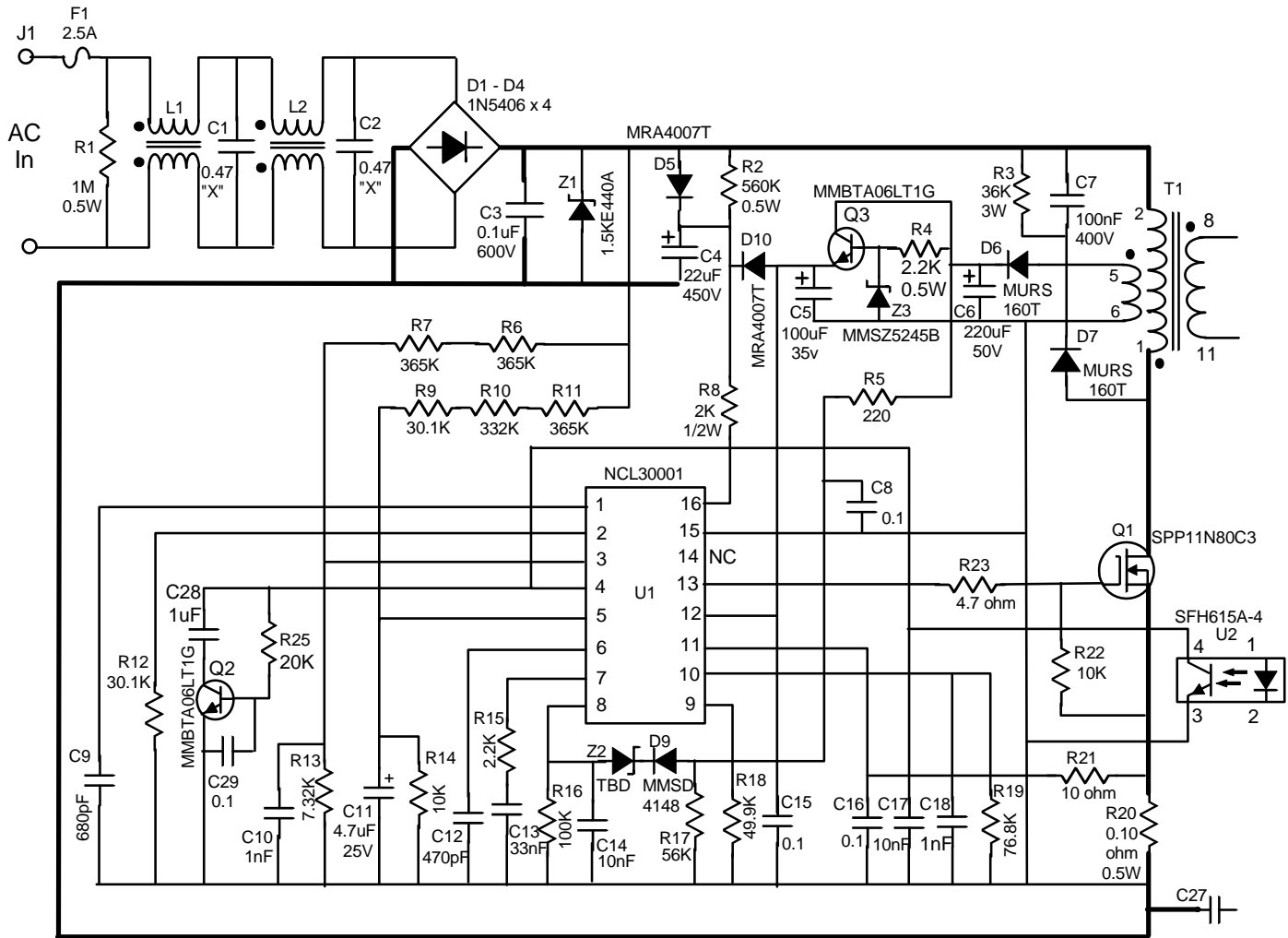

Notes:

1. Crossed schematic lines are not connected.
2. Heavy lines indicate power traces/planes.
3. Z2/D9 is for optional OVP (not used).
4. L1 is Coilcraft BU10-1012R2B or equivalent.
5. L2 is Coilcraft P3221-AL or equivalent.
6. L3 is Coilcraft RFB0807-3R3L or equivalent.
7. Q1 and D8 will require small heatsinks.

NCL30001 CVCC, 90 Watt Power Supply Primary Control Side Schematic

Figure 1: Primary Side Schematic

© 2010 ON Semiconductor.

Disclaimer: ON Semiconductor is providing this design note "AS IS" and does not assume any liability arising from its use; nor does ON Semiconductor convey any license to its or any third party's intellectual property rights. This document is provided only to assist customers in evaluation of the referenced circuit implementation and the recipient assumes all liability and risk associated with its use, including, but not limited to, compliance with all regulatory standards. ON Semiconductor may change any of its products at any time, without notice.

Design note created by Frank Cathell, e-mail: f.cathell@onsemi.com

DN06068/D

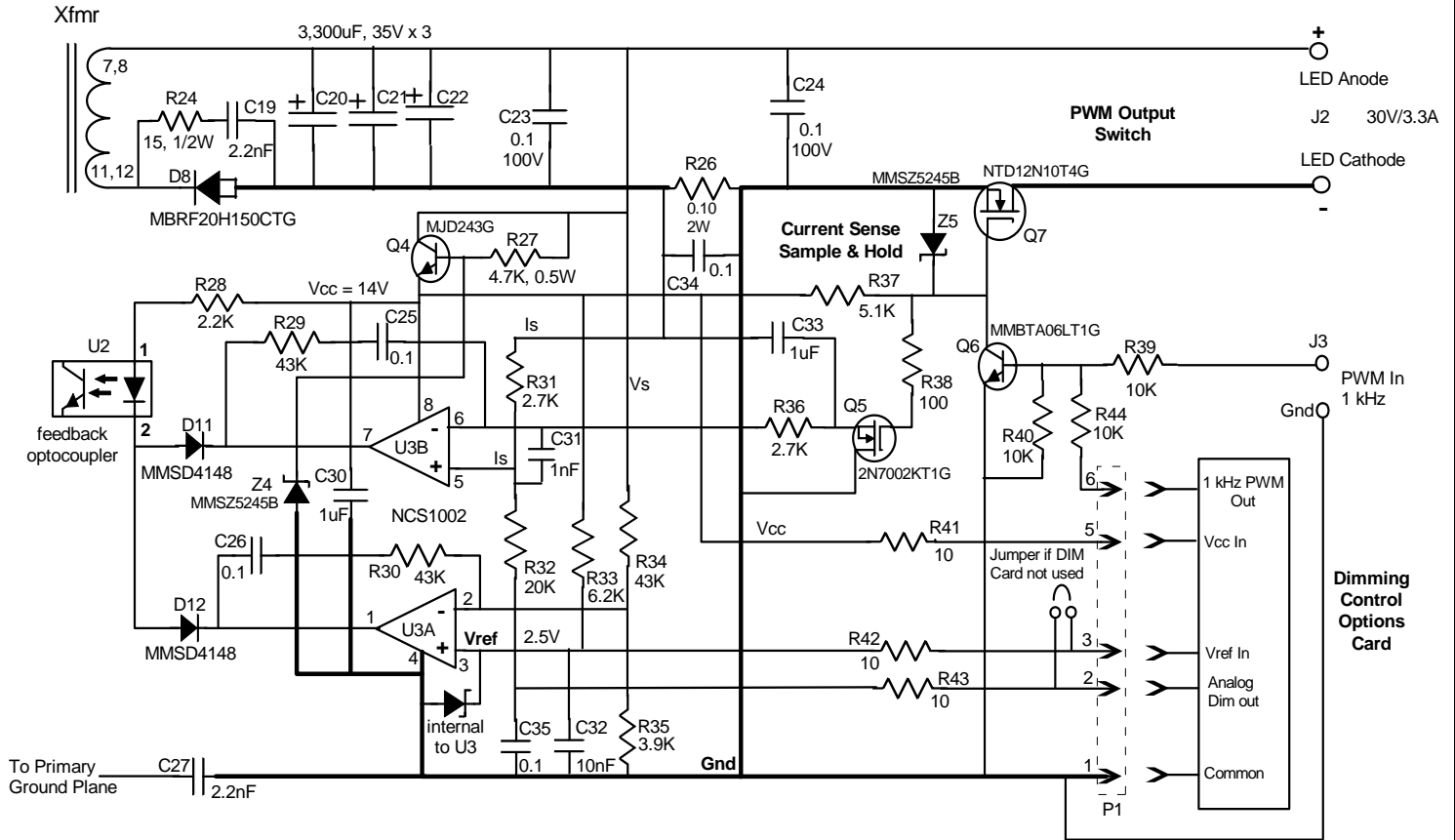

Notes:

1. R32 sets constant output current.
2. R34 sets maximum output voltage.
3. P1 connector should have pins 2 and 3 jumpered if DIM card is not used.
4. External PWM input for 200 Hz to 1 kHz.
5. D8 will require a small heatsink
6. Crossed lines on schematic are not connected.

30Vout LED Driver CVCC Secondary Sensing with
PWM Dimming Input & Option Card (Rev 2)

Figure 2: Secondary Side Schematic

© 2010 ON Semiconductor.

Disclaimer: ON Semiconductor is providing this design note "AS IS" and does not assume any liability arising from its use; nor does ON Semiconductor convey any license to its or any third party's intellectual property rights. This document is provided only to assist customers in evaluation of the referenced circuit implementation and the recipient assumes all liability and risk associated with its use, including, but not limited to, compliance with all regulatory standards. ON Semiconductor may change any of its products at any time, without notice.

Design note created by Frank Cathell, e-mail: f.cathell@onsemi.com

Test Results:

1) Efficiency with 3.3 A output:

<u>LED Forward Voltage (V)</u>	<u>120 Vac</u>	<u>230 Vac</u>
26.0	86%	87%
13.0	82%	84%

2) Power Factor during PWM Dimming ($V_f = 26V/I_{out} = 3.3A$)

<u>PWM Duty Ratio</u>	<u>120 Vac PFC</u>	<u>230 Vac PFC</u>
100%	0.98	0.98
75%	0.98	0.98
50%	0.98	0.98
25%	0.98	0.92
10%	0.98	0.75

3) Output Ripple at 120 Vac Input and 3.3 Amps Output

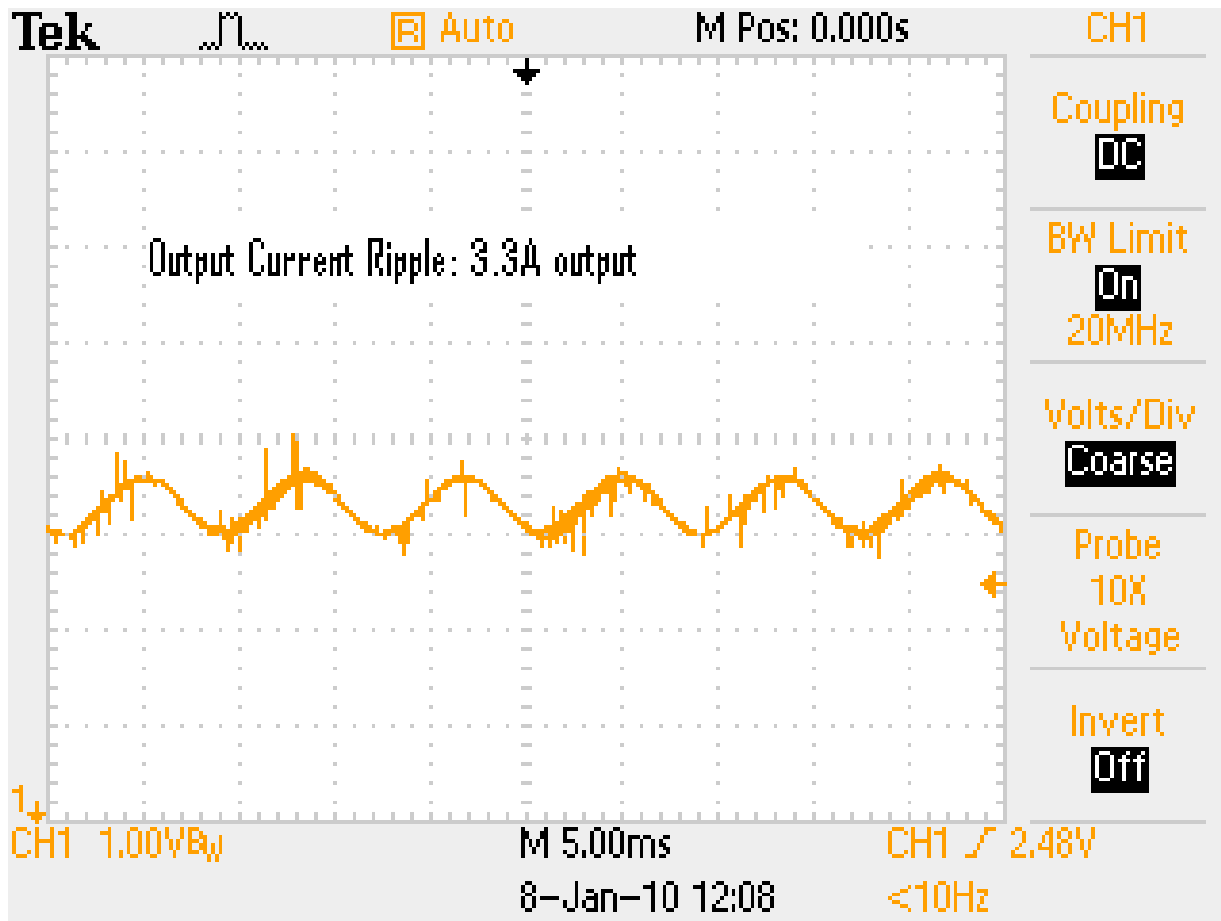

DN06068/D

4) Current Regulation Versus LED Forward Voltage

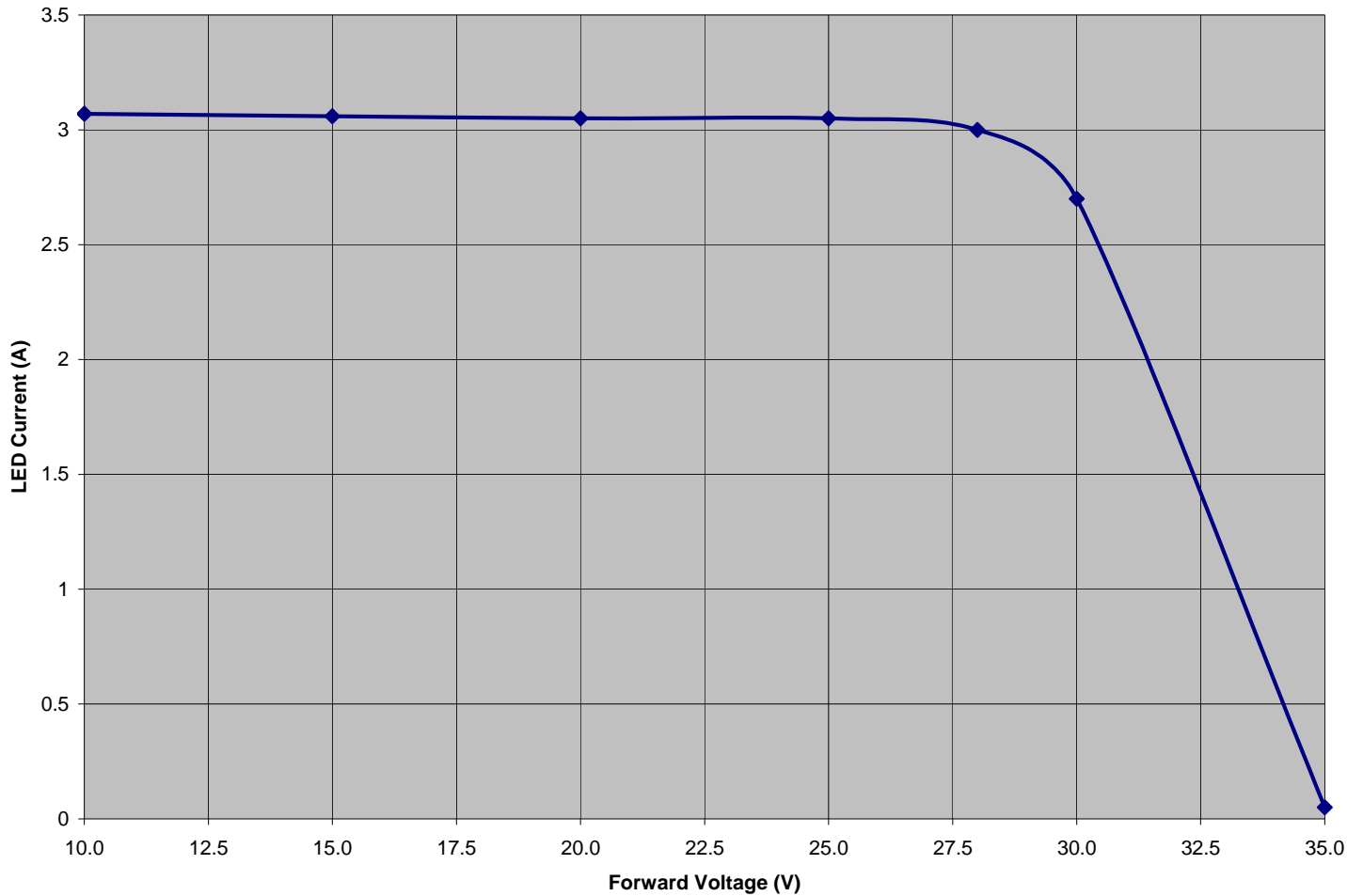

© 2010 ON Semiconductor.

Disclaimer: ON Semiconductor is providing this design note "AS IS" and does not assume any liability arising from its use; nor does ON Semiconductor convey any license to its or any third party's intellectual property rights. This document is provided only to assist customers in evaluation of the referenced circuit implementation and the recipient assumes all liability and risk associated with its use, including, but not limited to, compliance with all regulatory standards. ON Semiconductor may change any of its products at any time, without notice.

Design note created by Frank Cathell, e-mail: f.cathell@onsemi.com

MAGNETICS DESIGN DATA SHEET

Project: NCL30001, 90W, 28V CVCC LED driver

Part Description: CCM Flyback transformer, 70 kHz, 3.2 A, 30 Vout max

Schematic ID: T1

Core Type: PQ3230, 3C94 (Ferroxcube) or P material (Mag Inc.)

Core Gap: Gap core for 575 to 625 uH across pins 1 to 2.

Inductance: 600 uH nominal measured across primary (pins 1 to 2)

Bobbin Type: 12 pin pc mount (Mag Inc PC-B3230-12 or equivalent)

Windings (in order):

Winding # / type	Turns / Material / Gauge / Insulation Data
Primary A: (1 - 3)	28 turns of #24HN over one layer (no margins). Self-leads to pins. Insulate for 3 kV to next winding.
28V Secondary (7, 8 - 11, 12)	14 turns of 2 strands of #24HN flat wound (bifilar) over one layer with tape cuffed ends for safety (no margins) Terminate with 1 wire per pin as shown in drawing below. Insulate with tape for 3 kV to next winding.
Primary B: (3 - 2)	Same as primary A. Insulate for 1.5 kV to Vcc/Aux.
Vcc/Aux (5 - 6)	14 turns of #24HN spiral wound and centered with 8 mm end margins. Insulate with tape and terminate self-leads to pins.

Hipot: 3 kV from primary/Vcc to 28V secondary windings.

Schematic

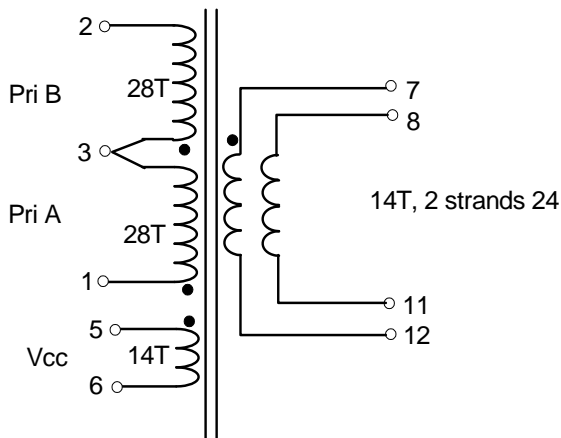

Lead Breakout / Pinout

(bottom view)

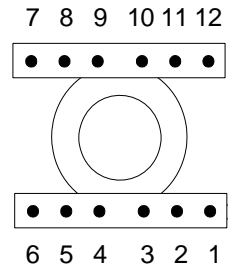

Würth Part #: 750311269

DN06068/D

Bill of Materials for 30V, 3.3 A NCL30001 CCCC LED Driver - PWM dimming (Rev 2 PCB, Version B)

ON Semiconductor



3/24/2010

Designator	Qty	Description	Value	Footprint	Manufacturer	Manufacturer Part Number	Substitution Allowed
D5, D10	2	Diode		SMA	ON Semiconductor	MRA4007T	No
D1, D2, D3, D4	4	Diode		axial lead	ON Semiconductor	1N5406	No
D6, D7	2	Ultrafast diode		SMB	ON Semiconductor	MURS160	No
D9, 11, 12, 13	4	Signal diode		SOD123	ON Semiconductor	MMSD4148A	No
D8	1	Schottky diode	20A, 150 V	TO-220ABCT	ON Semiconductor	MBRF20H150CTG	No
Z1	1	TVS	Input transient option	axial lead		1.5KE440A	Yes
Z3, 4, 5	3	Zener diode	15V	SOD123	ON Semiconductor	MMSZ5245B	No
Z2	-	Zener diode	Not Used	SOD123	ON Semiconductor	-	No
Q5	1	MOSFET	40V, 100 mA	SOT23	ON Semiconductor	2N7002KT1G	No
Q7	1	MOSFET	100V, A	DPak4	ON Semiconductor	NTD12N10T4G	No
Q1	1	MOSFET	11A, 800V	TO-220	Infineon	SPP11N80C3	No
Q2, Q3, Q6	3	BJT	60V, 500 mA	SOT23	ON Semiconductor	MMBT06L1G	No
Q4	1	BJT	100V, 4A	DPak4	ON Semiconductor	MJD243G	No
U1	1	PFC controller		SOIC16	ON Semiconductor	NCL30001	No
U2	1	Optocoupler		4 pin SMD	Vishay	H11A817 or SFH6156A-4	Yes
U3	1	Dual amp + zener		SOIC-8	ON Semiconductor	NCS1002	No
C1, C2	2	X caps	0.47 uF, 277 Vac	LS = 15mm	Evox Rifa/Kemet or EPCOS	PHE840MB6470MB16R17 or B32922C3474M	Yes
C27	1	Y2 cap	2.2 nF, 1kV	LS = 10 mm	Evox Rifa/Kemet	PME271Y422M or P271HE222M250A	Yes
C3	1	Polyprop. Film	0.22uF (630V)	LS=24 mm	Vishay	2222 383 20224	Yes (must be polyprop)
C7	1	Disc cap	68 to 100 nF, 400V	LS = 10 mm	TDK	FK22X7R2J104K	Yes -high quality ceramic
C8, 15, 16, 26, C25, 29, 34, 35	9	ceramic cap	0.1 uF, 50V	1206	TDK	C3216X7R2A104K	Yes
C23, C24	2	ceramic cap	0.1 uF, 100V	1206/1210	TDK	C3216X7R2A104K	Yes
C28, 30, 33	3	ceramic cap	1.0 uF, 25V	1206	TDK	C3216X7R1H105K	Yes
C19	1	ceramic disc cap	2.2 nF, 1 kV	LS = 8 mm	TDK	CK45-B3AD22KYNN	Yes
C12	1	ceramic cap	470 pF, 50V	1206	Vishay	VJ1206A471JXACW1BC	Yes
C9	1	ceramic cap	680 pF, 50V	1206	Kemet	C1206C681K5GACTU	Yes
C10, C18, C31	3	ceramic cap	1 nF, 100V	1206	Kemet	C1206C102K1RACTU	Yes
C14, C17, C32	3	ceramic cap	10 nF, 50V	1206	TDK	C3216COG2A103J	Yes
C13	1	ceramic cap	33 nF, 50V	1206	TDK	C3216COG1H333J	Yes
C5	1	electrolytic cap	100 uF, 35V	LS = 2.5 mm	UCC	ESMG350ELL101MF11D	Yes
C11	1	electrolytic cap	4.7 uF, 25V	LS = 2.5 mm	UCC	ESMG250ELL4R7ME11D	Yes
C6	1	electrolytic cap	220 uF, 50V	LS = 5mm	UCC	ESMG500ELL221MJC5S	Yes
C20, 21, 22	3	electrolytic cap	3,300 uF, 35V	LS = 8 mm	UCC	ESMG350ELL332MN25S	Yes
C4	1	electrolytic cap	22 uF, 450V	LS = 5 mm	Nichicon	647-UVY2W220MH0D	Yes
R4	1	0.5W resistor	2.2K	axial lead	Vishay	NFR25H0002201JR500	Yes
R1	1	0.5W resistor	1M, 0.5W	axial lead	Vishay	CMF601M0000FHEK	Yes
R8	1	0.5W resistor	2K, 0.5W	axial lead	Vishay	CMF552K0000FHEB	Yes
R2	1	0.5W resistor	560K	axial lead	Vishay	HVR3700005603JR500	Yes
R27	1	0.5W resistor	4.7K - 5.0K	1210	Vishay	CRCW12104K70JNEA	Yes
R24	1	0.5W resistor	15 ohms	axial lead	Vishay	CMF50015R00FHEB	Yes
R20, R26	2	2W resistor	0.1 ohms	LS = 18 mm	Ohmite	WNCR10FET	Yes
R3	1	3 or 5W resistor	36K to 39K	LS = 30 mm	Ohmite	PRO3000203602JAC00	Yes
R23	1	0.25W resistor	4.7 ohms	1206	Vishay/Dale	CRCW12064R75F	Yes
R5	1	0.25W resistor	220 ohms	1206	Vishay/Dale	CRCW1206220RF	Yes
R38	1	0.25W resistor	100 ohms	1206	Vishay/Dale	CRCW1206100RF	Yes
R21, 41, 42, 43	4	0.25W resistor	10 ohms	1206	Vishay/Dale	CRCW120610R0F	Yes
R15, R28	2	0.25W resistor	2.2K	1206	Vishay/Dale	CRCW12062211F	Yes
R31, R36	2	0.25W resistor	2.7K	1206	Vishay/Dale	CRCW12062741F	Yes
R25, R32	2	0.25W resistor	20K	1206	Vishay/Dale	CRCW12062002F	Yes
R33	1	0.25W resistor	6.2K	1206	Vishay/Dale	CRCW12066191F	Yes
R37	1	0.25W resistor	5.1K	1206	Vishay/Dale	CRCW12065111F	Yes
R29, 30, 34	3	0.25W resistor	43.2K	1206	Vishay/Dale	CRCW12068252F	Yes
R35	1	0.25W resistor	3.9K	1206	Vishay/Dale	CRCW12063921F	Yes
R14, 22, 39, 40, 44	5	0.25W resistor	10K	1206	Vishay/Dale	CRCW12061002F	Yes
R13	1	0.25W resistor	7.32K	1206	Vishay/Dale	CRCW12067321F	Yes
R9, R12	2	0.25W resistor	30.1K	1206	Vishay/Dale	CRCW12063012F	Yes
R17	1	0.25W resistor	56K	1206	Vishay/Dale	CRCW12065622F	Yes
R18	1	0.25W resistor	49.9K	1206	Vishay/Dale	CRCW12064992F	Yes
R19	1	0.25W resistor	76.8K	1206	Vishay/Dale	CRCW12067682F	Yes
R16	1	0.25W resistor	100K	1206	Vishay/Dale	CRCW12061003F	Yes
R10	1	0.25W resistor	332K	1206	Vishay/Dale	CRCW12063323F	Yes
R6, 7, 11	3	0.25W resistor	365K	1206	Vishay/Dale	CRCW12063653F	Yes
F1	1	Fuse	2.5A, 250Vac	TR-5	Littlefuse	37212500411	Yes
L1	1	EMI inductor		E/E core	Coilcraft	BU10-1012R2B	Yes
L2	1	EMI inductor		Toroid	Coilcraft	P3221-AL	Yes
T1	1	Flyback xfmr	30V, 90W CCM	-	Würth-Midcom	750311269, Rev 00	No
J1, J2, J3	3	I/O connectors		LS = 5 mm	Weidmuller	1716020000	Yes
HD1	1	Header	2POS	0.100"	Molex	90120-0122	Yes
JMP1	1	Shorting Jumper		0.100"	Sullins	SPC02SYAN	Yes
(for Q1, D8)	2	Heatsink Q1, D8		LS = 25.4 mm	AAVID	531102B02500G	Yes

Note: **BOLD** components indicated changes from 50V/1A Demo board schematic
All components are PB-Free