

DN06067/D

Three LED 300 mA MR16 Driver



ON Semiconductor®

<http://onsemi.com>

DESIGN NOTE

Table 1. DEVICE DETAILS

Device	Application	Input Voltage	Output Power	Topology	I/O Isolation
CAT4201	MR-16 LED Lamp	12 Vac	2.7 W	Step-down	None

Table 2. OTHER SPECIFICATIONS

	Output
Output Voltage	9.1 V
Nominal Input Power	3.4 W
Nominal Average Current	300 mA
Max Average Current	310 mA
Min Average Current	295 mA
Typical Efficiency	83%

Table 3. LED KEY SPECIFICATIONS

LED	Maximum Rating	Forward Voltage @ 350 mA	Typical Color	Typical Luminous Flux @ 350 mA
CREE Xlamp® XR-E	1 A/3.7 W	3.3 V	Cool White	107 lm

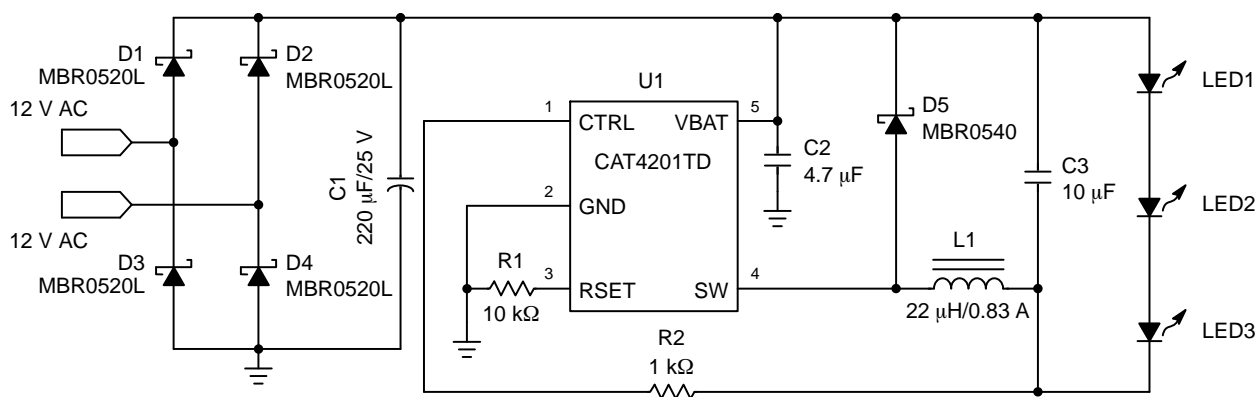

Figure 1. Schematic

Circuit Description

The CAT4201 is a step-down, easy-to-configure, dimmable LED driver. The package is a 5-pin SOT-23; with fewer than 10 discrete components (most of them surface mount), the whole PCB can be small enough to fit into the base of an MR16 bulb. The voltage ratings on pins VBAT, CTRL and SW are 40 V, so driving 12 LEDs is possible with

adequate voltage. The RSET pin determines the output DC current; CTRL is for dimming signal input. SW is the output of internal MOSFET.

The CAT4201 driver is strongly recommended for its compact circuitry and high efficiency making it ideally suited for the replacement of filament-based bulb, in applications such as spot light.

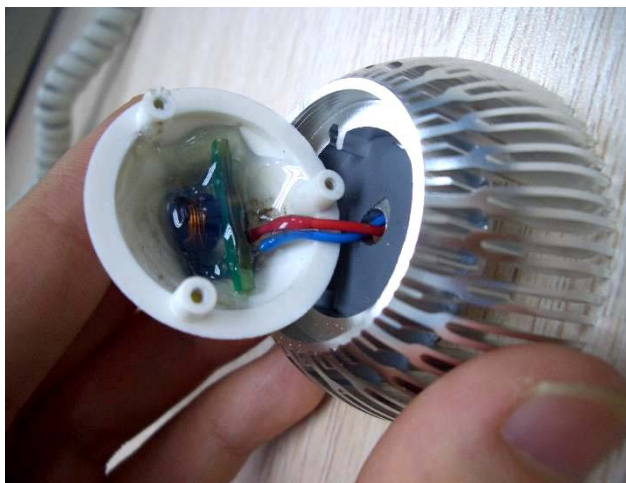

Figure 2. MR-16 LED Cases. Miniature LED Driver Board can be Embedded into the Base

Theory of Operation

The application circuit is a simple buck converter. In the case of AC applications, the input is rectified through a bridge rectifier. VBAT and GND are directly connected to the two terminals of the bulk capacitor C1 which reduces the current ripple. During the first switching phase, the internal MOSFET will charge the inductor with linearly rising current until the switching-off of MOSFET; during the second phase, the MOSFET is cut off, and the current stored in the inductor will discharge through the Schottky diode (D5), and the current decays till next period of switching. The output capacitor is used to reduce the current ripple in the LED. RSET is voltage regulated at 1.2 V, thus resistor connected to RSET determines the RSET current. The RSET current is approximately proportional to the output constant current of CAT4201.

Circuit Configuration

VBAT has a voltage rating of -0.3 to $+40$ V, therefore an input voltage up to 24 Vac at the bridge is safe. A large C1 is necessary to keep a higher level of input voltage. Large fluctuation of rectified AC current will pull the output current to zero at double line frequency, thus reducing the output current. 220 μ F is adequate in this design. Voltage rating of C1 should be 25 V for 12 Vac input. MBR0520L was selected for the bridge rectifier because of its low forward voltage.

It is recommended to use at least 4.7 μ F for C2 as output capacitor to reduce output ripple. Larger C2 will effectively suppress the output ripple, and raise the output current by several milliamperes. However since its contribution to total efficiency is insignificant and that human eye cannot sense

high frequency fluctuation, capacitance larger than 10 μ F is not necessary. The value of L is recommended to be 22 μ H in order to set a proper switching frequency about 150 kHz. The LED current range is 0~350 mA, so the rms current rating of inductor around 800 mA is adequate.

The total continuous current though the rectifiers are always below 400 mA even though 350 mA output current is supplied. Therefore a 0.5 A continuous current rating is enough for rectifiers. Careful observation of voltage across the freewheeling D5 diode shows that voltage spikes over 20 V can be found even with 12 Vac input. A higher input voltage (such as 15 V) further stresses the diode, increasing the risk of failure. So the voltage rating on D5 should be 30 V or 40 V. ON Semiconductor's Schottky rectifier MBR0540 was selected for D5.

RSET pin configures the value of the output current. RSET voltage is regulated at 1.2 V. Adding a resistor between RSET and GND determines the RSET current, which has an approximately linear relationship with output constant voltage:

$$I_{LED} = 2500 \cdot I_{RSET} \quad (\text{eq. 1})$$

It can be calculated that for 300 mA output, $I_{RSET} = 0.12$ mA. The RSET resistor value should be 10 k Ω .

A smaller RSET resistance will possibly increase the output current, but it is recommended to use at least 8.0 k Ω for stable operation. If the input voltage is high enough (e.g. 15 Vac), one can set RSET to be 8.2k, which guarantees at least 350 mA output.

CTRL derives voltage from the cathode of LED through R2. Value of R2 is not critical.

Performance and Characteristics

1. Input Voltage – Output Current – Efficiency Relationship*

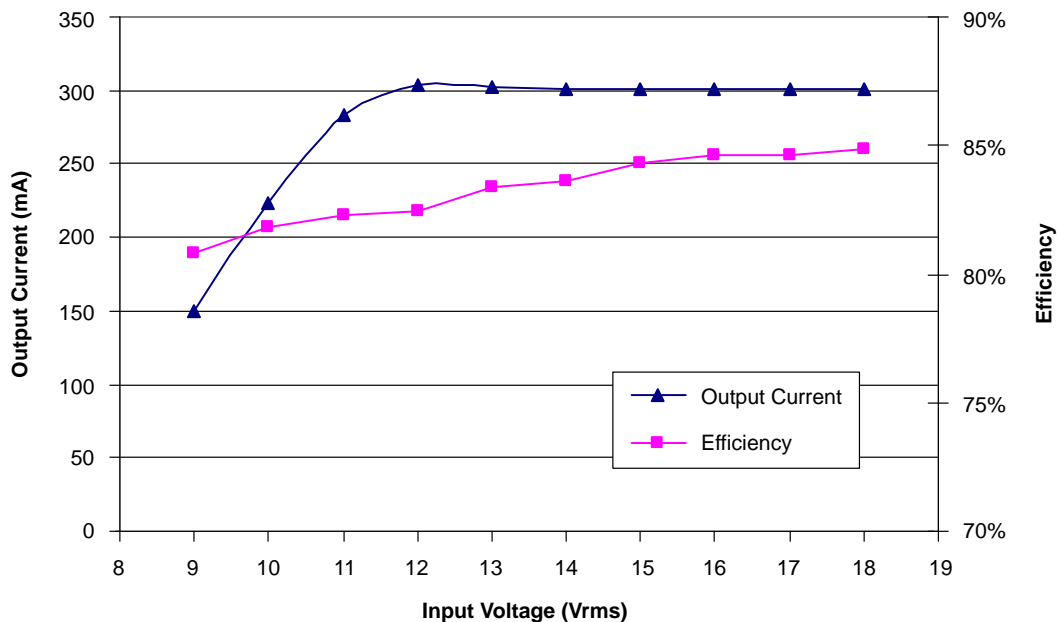

*Equipment: Global Specialties 1506 AC isolated variable AC line supply; Voltech PM1000 AC Power analyzer; Tektronix TDS754D digital phosphor oscilloscope; Tektronix TCP202 current probe; Agilent 34401A multimeter.

2. LED Current Waveforms*

$V_{IN} = 12$ Vac 50 Hz, circuit is configured according to the schematic in page 1 of this document.

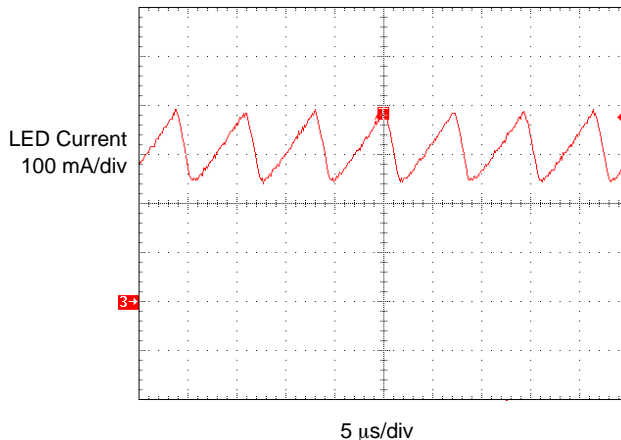
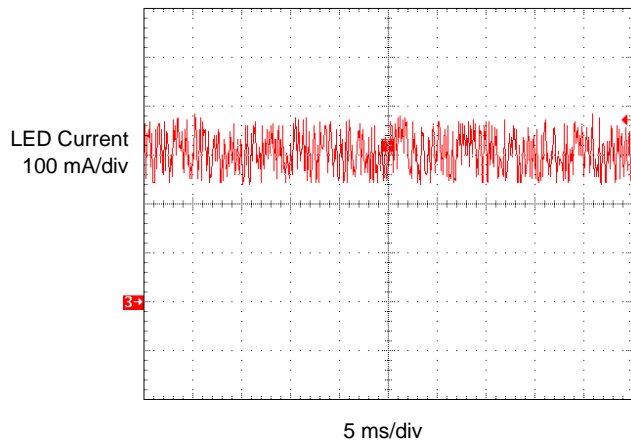

The LED current has got very slight low frequency (at twice the AC frequency, 2×50 Hz here) fluctuation due to the AC line input.

Using larger C1 or higher V_{IN} will further flatten the AC related ripple current.

3. Startup and Power Down Transient*

$V_{IN} = 12 \text{ Vac}$ 50 Hz, circuit is configured according to the schematic in page 1 of this document.

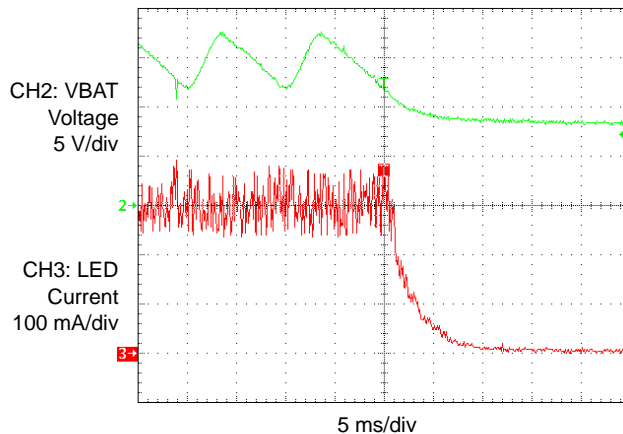
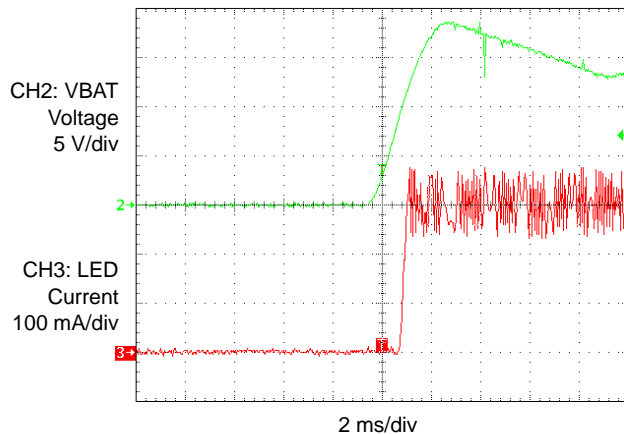

*Equipment: Global Specialties 1506 AC isolated variable AC line supply; Voltech PM1000 AC Power analyzer; Tektronix TDS754D digital phosphor oscilloscope; Tektronix TCP202 current probe.

Conclusion

The information presented in this design note covers the various factors required about designing a three-LED MR-16 lamp using the CAT4201. The CAT4201 allows smaller footprint, fewer components for a MR-16 compatible adapter.

Reducing capacitor and inductor values, or removing the CTRL resistor is possible for further reduction of the cost and PCB size. Using a small bulk capacitor will lead to large drop of average output current, which is not recommended, but suitable for applications with less brightness (200~250 mA). Selecting high-quality LEDs with smaller forward voltage is very important in this design to achieve a higher output current.

References

- [1] Data Sheet [CAT4201](#): 350 mA High Efficiency Step Down LED Driver
- [2] Data Sheet [MBR0520L](#): 0.5 A, 20 V Schottky Rectifier
- [3] Data Sheet [MBR0540](#): 0.5 A, 40 V Schottky Rectifier

DN06067/D

Table 4. BILL OF MATERIALS

Part	Specifications and Ratings	Manufacturer
CAT4201TD	SOT-23, 40 V, 350 mA	ON Semiconductor
MBR0520L	0.5 A, 20 V SMT Schottky Rectifier, $V_f = 0.38$ V	ON Semiconductor
MBR0540	0.5 A, 40 V SMT Schottky Rectifier, $V_f = 0.51$ V	ON Semiconductor
LEDs	CREE Xlamp 7090 XR-E, Cool White, Group Q5	Cree
L1	22 μ H, 0.9 A, 0.83 A (Isat.) Shielded $4 \times 4 \times 1.8$ mm (LPS4018-223)	Coilcraft
C1	220 μ F, 25 V	Panasonic
C2	4.7 μ F, 25 V 1206 Ceramic	TDK
C3	10 μ F, 16 V Ceramic	TDK
R1	10 k Ω 1/8 W SMT-0805, 1%	-
R2	1 k Ω 1/8 W SMT-0805, 5%	-

XLamp is a registered trademark of Cree, Inc

ON Semiconductor and the  are registered trademarks of Semiconductor Components Industries, LLC (SCILLC) or its subsidiaries in the United States and/or other countries. SCILLC owns the rights to a number of patents, trademarks, copyrights, trade secrets, and other intellectual property. A listing of SCILLC's product/patent coverage may be accessed at www.onsemi.com/site/pdf/Patent-Marking.pdf. SCILLC reserves the right to make changes without further notice to any products herein. SCILLC makes no warranty, representation or guarantee regarding the suitability of its products for any particular purpose, nor does SCILLC assume any liability arising out of the application or use of any product or circuit, and specifically disclaims any and all liability, including without limitation special, consequential or incidental damages. "Typical" parameters which may be provided in SCILLC data sheets and/or specifications can and do vary in different applications and actual performance may vary over time. All operating parameters, including "Typicals" must be validated for each customer application by customer's technical experts. SCILLC does not convey any license under its patent rights nor the rights of others. SCILLC products are not designed, intended, or authorized for use as components in systems intended for surgical implant into the body, or other applications intended to support or sustain life, or for any other application in which the failure of the SCILLC product could create a situation where personal injury or death may occur. Should Buyer purchase or use SCILLC products for any such unintended or unauthorized application, Buyer shall indemnify and hold SCILLC and its officers, employees, subsidiaries, affiliates, and distributors harmless against all claims, costs, damages, and expenses, and reasonable attorney fees arising out of, directly or indirectly, any claim of personal injury or death associated with such unintended or unauthorized use, even if such claim alleges that SCILLC was negligent regarding the design or manufacture of the part. SCILLC is an Equal Opportunity/Affirmative Action Employer. This literature is subject to all applicable copyright laws and is not for resale in any manner.

PUBLICATION ORDERING INFORMATION

LITERATURE FULFILLMENT:

Literature Distribution Center for ON Semiconductor
P.O. Box 5163, Denver, Colorado 80217 USA
Phone: 303-675-2175 or 800-344-3860 Toll Free USA/Canada
Fax: 303-675-2176 or 800-344-3867 Toll Free USA/Canada
Email: orderlit@onsemi.com

N. American Technical Support: 800-282-9855 Toll Free
USA/Canada
Europe, Middle East and Africa Technical Support:
Phone: 421 33 790 2910
Japan Customer Focus Center
Phone: 81-3-5817-1050

ON Semiconductor Website: www.onsemi.com

Order Literature: <http://www.onsemi.com/orderlit>

For additional information, please contact your local Sales Representative