



# NCP3065 SEPIC LED Driver for MR16

ON Semiconductor

Device	Application	Input Voltage	Output Power	Topology	I/O Isolation
NCP3065 NCV3065	Solid State, Automotive and Marine Lighting	8-20 V, 12Vdc, 12Vac	<15 W	SEPIC	NONE

## Other Specifications

	Output 1	Output 2	Output 3	Output 4
<b>Output Voltage</b>	7.2-23 V	N/A	N/A	N/A
<b>Current Ripple</b>	<15 %	N/A	N/A	N/A
<b>Nominal Current</b>	0.35, 0.7, 1.0 A	N/A	N/A	N/A
<b>Max Current</b>	1 A	N/A	N/A	N/A
<b>Min Current</b>	N/A	N/A	N/A	N/A

<b>Minimum Efficiency</b>	75%
---------------------------	-----

## Circuit Description

This design note describes a DC-DC converter circuit that can be easily configured to drive LEDs at several different output currents and voltage. It can be configured for either AC or DC low voltage input. It is proposed for driving High Brightness LEDs such as Lumileds Luxeon™, Osram Ostar™, TopLED™ and Golden Dragon as well as the Cree XLAMP™ etc. and it is designed for replace traditional MR16 bulbs with LEDs like mentioned above. MR16 input voltage range is usually 12 Vdc and 12Vac but you can use this circuit for wide input voltage. You have to only think about right component selection. The circuit uses the NCP3065 switching regulator configured to drive a series string of LEDs in constant current mode.

NCP3065 is monolithic power switching regulator capable of delivering 1.5A at output voltages 0.235V to 35V. Circuit benefit is in the wide input and output voltage range and in the high efficiency and small application volume.

The brightness of the LED or light intensity as measured in Lumens is proportional to the forward current flowing through the LED. Dimming PWM input is included.

Pulse Feedback resistor (R2) is used to vary the slope of the oscillator ramp, achieve duty cycle control and stabilize switching frequency in the wide input voltage range.

This demo board can be ordered from ON web site, its name is NCP3065D1SLDGEVB.

## Key Features

- Buck-Boost operation
- Wide input and output operation voltage
- Regulated average output current
- Overcurrent and overvoltage protection included
- PWM Dimming input
- High operation frequency
- Minimal input and output current ripple
- Whole application in circle with 30mm diameter
- Designed for MR16 bulbs

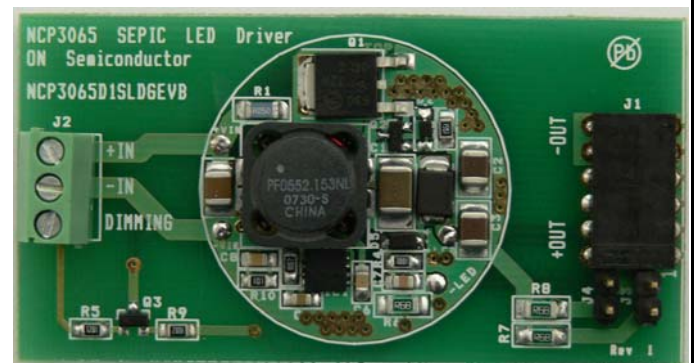


Figure 1 – Demo board top view

Schematic

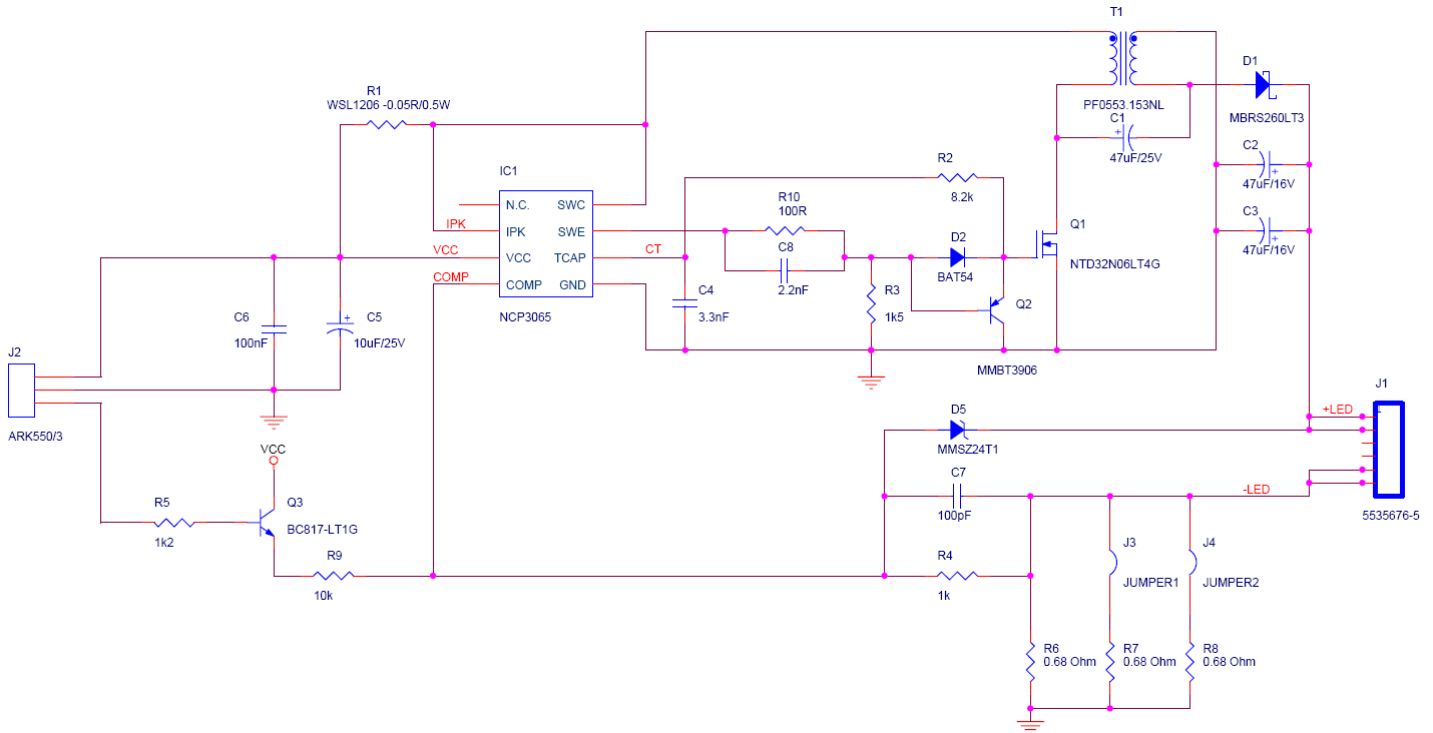


Figure 2 – MR16 SEPIC converter schematic

Design Notes

A SEPIC (single-ended primary inductance converter) is distinguished by the fact that its input voltage range can overlap the output voltage range. There is principal schema is shown in Figure 3.

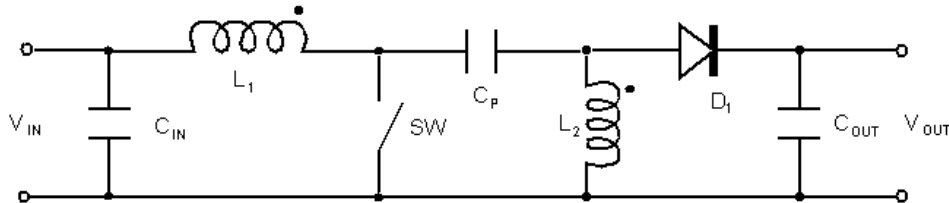


Figure 3 – Principal SEPIC schematic

When switch SW is ON, energy from the input is stored in inductor L<sub>1</sub>. Capacitor C<sub>P</sub> is connected in parallel to L<sub>2</sub>, and energy from C<sub>P</sub> is transferred to L<sub>2</sub>. The voltage across L<sub>2</sub> is the same as the C<sub>P</sub> voltage, which is the same as the input voltage. At this time, the diode is reverse biased and C<sub>OUT</sub> supplies output current.

If the switch SW is OFF, current in L<sub>1</sub> flows through C<sub>P</sub> and D<sub>1</sub> then continues to the load and C<sub>OUT</sub>. This current recharges C<sub>P</sub> for the next cycle. Current from L<sub>2</sub> also flows through D<sub>1</sub> to the load and C<sub>OUT</sub> that is recharging for the next cycle.

Inductors L<sub>1</sub> and L<sub>2</sub> could be uncoupled, but then they must be twice as large as if they are coupled. Another advantage is that if coupled inductors are used there is very small input current ripple.

Values of coupled inductors are set by these equations

$$D = \frac{V_{OUT_{min}} + V_F}{V_{OUT_{min}} + V_{IN_{min}} + V_F} = \frac{7,2 + 0,4}{7,2 + 8 + 0,4} = 0,487$$

Load current 350mA:

$$\Delta I = r \cdot I_{OUT} \frac{D}{1-D} = 0,8 \cdot 0,35 \cdot \frac{0,487}{1-0,487} = 0,266A$$

$$L_{1,2} = \frac{V_{IN_{min}} \cdot D}{2 \cdot f \cdot \Delta I} = \frac{8 \cdot 0,487}{2 \cdot 250 \cdot 10^3 \cdot 0,266} = 29,3 \mu H$$

Load current 700mA:

$$\Delta I = r \cdot I_{OUT} \frac{D}{1-D} = 0.8 \cdot 0.7 \cdot \frac{0.487}{1-0.487} = 0.532A \quad L_{1,2} = \frac{V_{INmin} \cdot D}{2 \cdot f \cdot \Delta I} = \frac{8 \cdot 0.487}{2 \cdot 250 \cdot 10^3 \cdot 0.532} = 14.6\mu H$$

Load current 1000mA:

$$\Delta I = r \cdot I_{OUT} \frac{D}{1-D} = 0.8 \cdot 1 \cdot \frac{0.487}{1-0.487} = 0.76A \quad L_{1,2} = \frac{V_{INmin} \cdot D}{2 \cdot f \cdot \Delta I} = \frac{8 \cdot 0.487}{2 \cdot 250 \cdot 10^3 \cdot 0.76} = 10.3\mu H$$

where r is the maximum inductor current ripple factor.

The nearest coupled inductor values for the 0.7 A variant is 15  $\mu$ H.

Output current is set by  $R_S$  ( $R_6$ ,  $R_7$  and  $R_8$ ) value. So this resistor can be calculating by the formula:

$$R_S = \frac{0,235}{I_{OUT}}$$

On the evaluation board, the value of  $R_S$  can be selected by jumpers  $J_3$ ,  $J_4$ . When both are open output current is setup to 350mA. With  $J_3$  shorted, the output current increase to 700mA and when you shorted both  $J_3$  and  $J_4$  you setup output current to 1A.

To protect the circuit against high output voltage on light loads or load disconnection, output voltage is clamped by a Zener diode ( $D_5$ ) to approximately 24.5 V.

External power MOSFET is forced by internal NPN Darlington transistor, by driver from external diode  $D_2$  and by PNP transistor  $Q_2$ . Maximum MOSFET current can be calculated by this formula:

$$I_{Q1max} = \left(1 + \frac{r}{2}\right) \cdot I_{OUT} \frac{U_{OUTmax}}{U_{INmin}} = \left(1 + \frac{0,8}{2}\right) \cdot 0,7 \cdot \frac{23}{8} = 2,5A$$

To minimize power MOSFET conductance losses, it is recommended to select a transistor with small  $R_{DS(ON)}$ . To minimize switching losses, it is recommended to select a transistor with small gate charge. Power MOSFET must also have a breakdown voltage higher than:

$$V_{FETPK} = V_{IN} + V_{OUT} = 20 + 23 = 43V$$

Switch peak current protection is set by  $R_1$  at

$$I_{PKset} = \frac{0,2}{R1}$$

A suitable value is higher than maximum switch current.

$$R_1 < \frac{0,2}{I_{Q1max}} = \frac{0,2}{2,5} = 80m\Omega$$

Diode  $D_1$  is stressed with reverse voltage

$$V_{D1max} = V_{IN} + V_{OUT} = 20 + 23 = 43V$$

and with current

$$I_{D1} = I_{OUT} = 0,7A$$

The  $C_1$  coupling capacitor is stressed on input voltage and on current

$$D_{max} = \frac{V_{OUTmax}}{V_{OUTmax} + V_{INmin}} = \frac{23}{23 + 8} = 0,74$$

$$I_{C2RMS} = \frac{V_{OUT} \cdot I_{OUT}}{V_{IN}} \sqrt{\frac{1-D_{max}}{D_{max}}} = \frac{23 \cdot 0,7}{8} \sqrt{\frac{1-0,74}{0,74}} = 1,2A$$

and its minimal value is

$$C_2 > \frac{I_{OUT} \cdot D_{min}}{0,05 \cdot V_{INmin} \cdot f} = \frac{0,7 \cdot 0,47}{0,05 \cdot 8 \cdot 250 \cdot 10^3} = 2\mu F$$

## DN06033/D

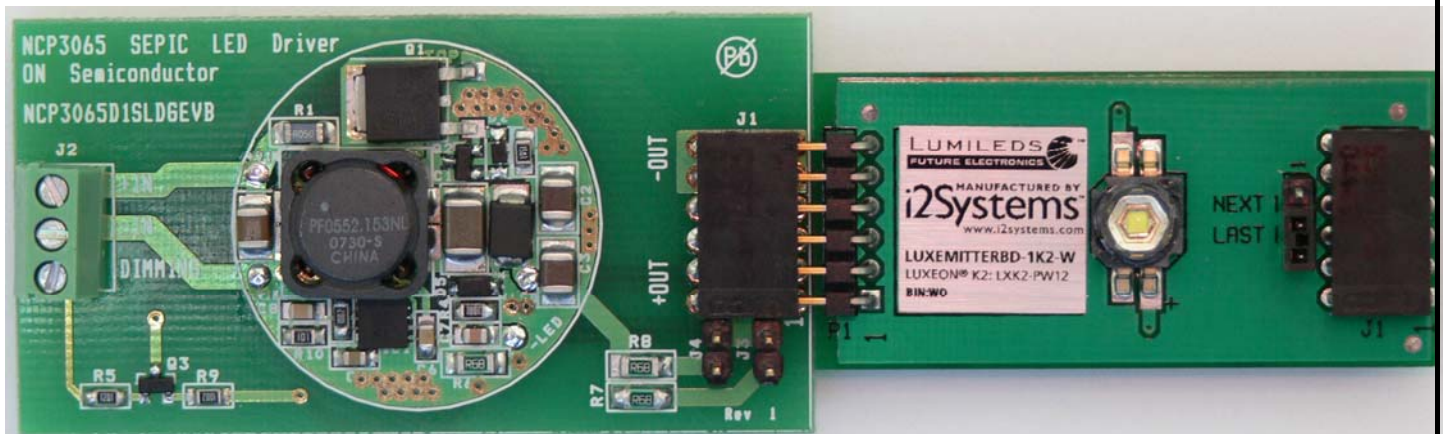
### Application

LEDs configuration	Output current	Pulse feedback resistor R2 value	
		Input voltage	
		12 Vdc	12 Vac
$V_f = 7.2V$	350mA	7.5k	5.1k
	700mA	6.2k	4.3k
	1000mA	5.1k	5.1k
$V_f = 10.8V$	350mA	8.2k	6.8k
	700mA	8.2k	5.1k
	1000mA	9.1k	8.2k
$V_f = 14.4V$	350mA	13k	12k
	700mA	10k	10k
	1000mA	28k	11k

$J_{2-3}$  input is used for dimming. The dimming signal level is 2-10 V or can be used TTL compatible signal. Recommended dimming frequency is about 200 Hz. For frequencies below 100 Hz the human eye will see the flicker. The low dimming frequencies are EMI convenient. Dimming function is based on the NCP3065's feedback input. The second way to achieve this is to use the  $I_{PK}$  pin as can be seen in application note AND8298.

### Conclusion

This circuit was developed based on requirements for replacing traditional MR16 bulb with new High brightness LEDs. This circuit is ideal in applications with strings of two to six LED chips connected in series, everywhere where input and output voltage overlap. The advantages of this circuit include its small size, low price, wide input and output voltage ranges, and very small input current ripple.



**Figure 4 – Application example top side**

PC Board

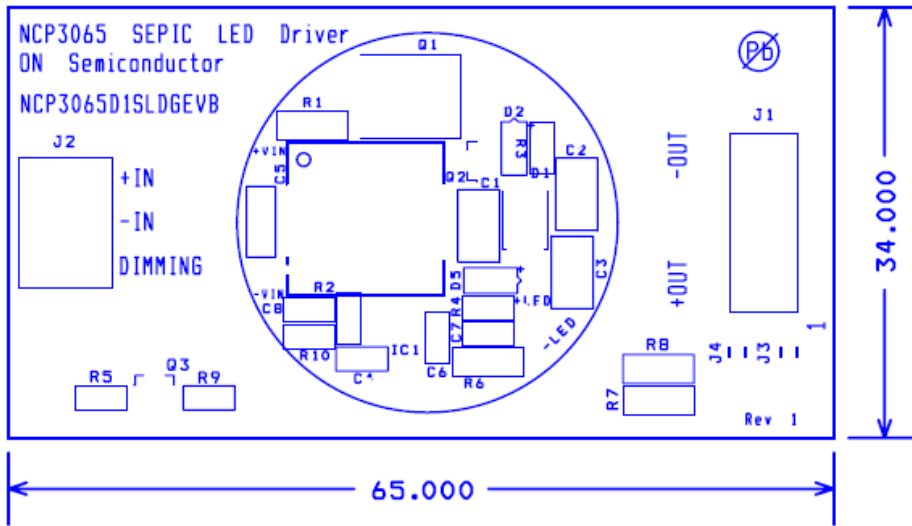


Figure 5 – components position on PCB

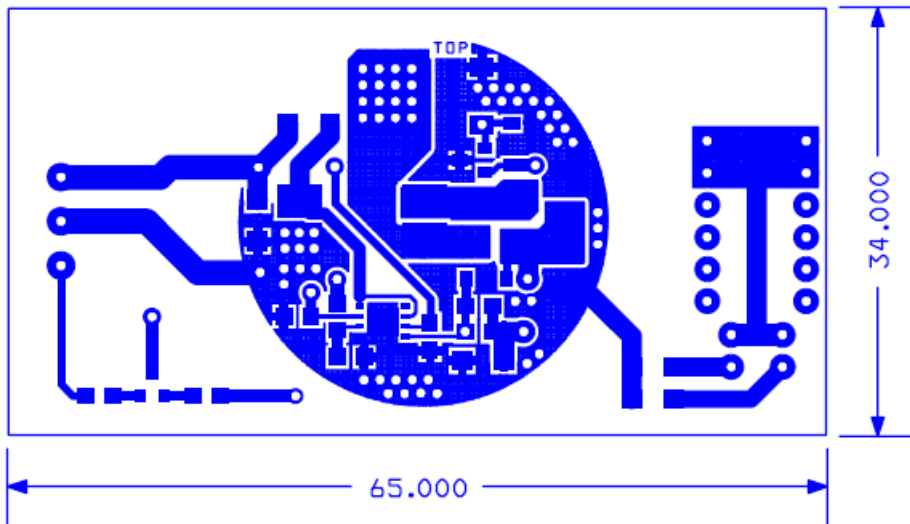


Figure 6 – PCB's top side – not in scale

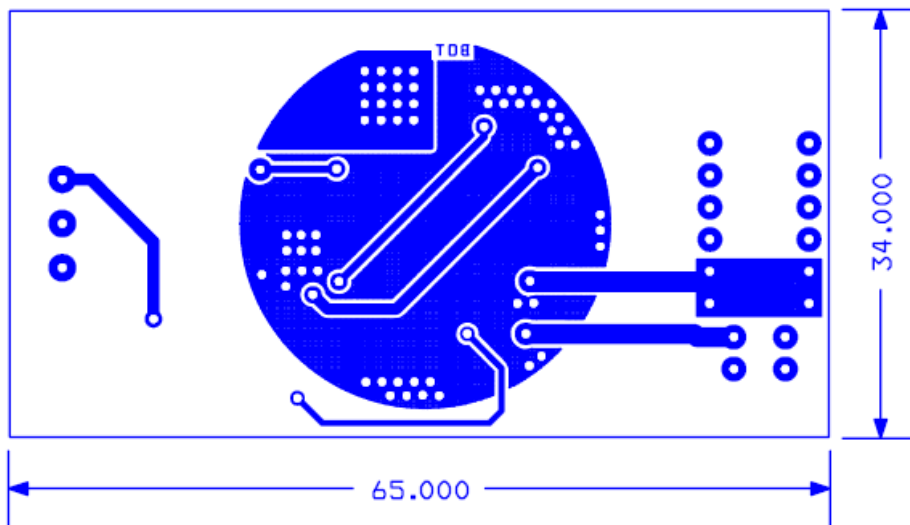


Figure 7 – PCB's bottom side – not in scale

DN06033/D

Table 1– Bill of materials

Designator	Quantity	Description	Value	Tolerance	Footprint	Manufacturer	Manufacturer Part Number	Substitution Allowed	Lead Free	Comments
C1	1	Ceramic capacitor SMD	47uF/25V	20%	1812	Taiyo Yuden	TMK432C476MM-T	Yes	Yes	
C2, C3	2	Ceramic capacitor SMD	47uF/16V	20%	1210	Taiyo Yuden	EMK325BJ476MM-T	Yes	Yes	
C4	1	Ceramic capacitor SMD	3.3nF	5%	0805	TDK	C2012C0G1H332J	Yes	Yes	
C5	1	Ceramic capacitor SMD	10uF/25V	20%	1210	Taiyo Yuden	TMK325BJ106MM-TR	Yes	Yes	
C6	1	Ceramic capacitor SMD	100nF	10%	0805	TDK	C2012X7R1H104K	Yes	Yes	
C7	1	Ceramic capacitor SMD	100pF	5%	0805	TDK	C2012C0G1H101J	Yes	Yes	
C8	1	Ceramic capacitor SMD	2.2nF	10%	0805	TDK	C2012X7R2A222K	Yes	Yes	
D1	1	Surface Mount Schottky Power Rectifier	MBRS260T3G	-	SMB	ON Semiconductor	MBRS260T3G	No	Yes	
D2	1	Schottky Diode 30V	BAT54T1G	-	SOD-123	ON Semiconductor	BAT54T1G	No	Yes	
D5	1	Zener Diode 500 mW 24 V	MMSZ24T1G	5%	SOD-123	ON Semiconductor	MMSZ24T1G	No	Yes	
J1	1	AMPMODU Mod II Right-Angle Horizontal PCB Connector	5535676-5	-	-	TYCO	5535676-5	Yes	Yes	
J2	1	Input connector	DG350-3.50-03	-	-	Degson	DG350-3.50-03	Yes	Yes	
J3, J4	2	Jumper, RM 2.54 mm	Jumper	-	2.54	Harwin	M7686-05	Yes	Yes	
J3, J4	2	Jumper, RM 2.54 mm, PCB pin's	Jumper - PCB pin's	-	0003	Harwin	M20-9990205	Yes	Yes	
Q1	1	Power MOSFET 32Amps, 60Volts, Logic Level, N-Channel	NTD32N06LT4G	-	DPAK	ON Semiconductor	NTD32N06LT4G	No	Yes	
Q2	1	PNP General Purpose Transistor	MMBT3906LT1G	-	SOT-23	ON Semiconductor	MMBT3906LT1G	No	Yes	
Q3	1	General Purpose Transistor NPN	BC817-40LT1G	-	SOT-23	ON Semiconductor	BC817-40LT1G	No	Yes	
R1	1	Resistor SMD	WSL1206 -0.05R/0.5W	1%	1206	Welvyn	WSL1206 -0.05R/0.5W	Yes	Yes	
R2	1	Resistor SMD	8k2	1%	0805	Vishay	CRCW08058K20FKEA	Yes	Yes	
R3	1	Resistor SMD	1k5	1%	0805	Vishay	CRCW08051K50FKEA	Yes	Yes	
R4	1	Resistor SMD	1k	1%	0805	Vishay	CRCW08051K00FKEA	Yes	Yes	
R5	1	Resistor SMD	1k2	1%	0805	Vishay	CRCW08051K20FKEA	Yes	Yes	
R6, R7, R8	3	Resistor SMD	0R68	5%	1206	Tyco Electronics	RL73K2BR68JTD	Yes	Yes	
R9	1	Resistor SMD	10k	1%	0805	Vishay	CRCW080510K0FKEA	Yes	Yes	
R10	1	Resistor SMD	100R	1%	0805	Vishay	CRCW0805100RFKEA	Yes	Yes	
T1	1	Dual inductor	PF0553.153NL	-	-	Pulse Eng.	PF0553.153NL	Yes	Yes	
IC1	1	Constant Current Switching Regulator	NCV3065MNTXG	-	DFN	ON Semiconductor	NCV3065MNTXG	No	Yes	

Measurements

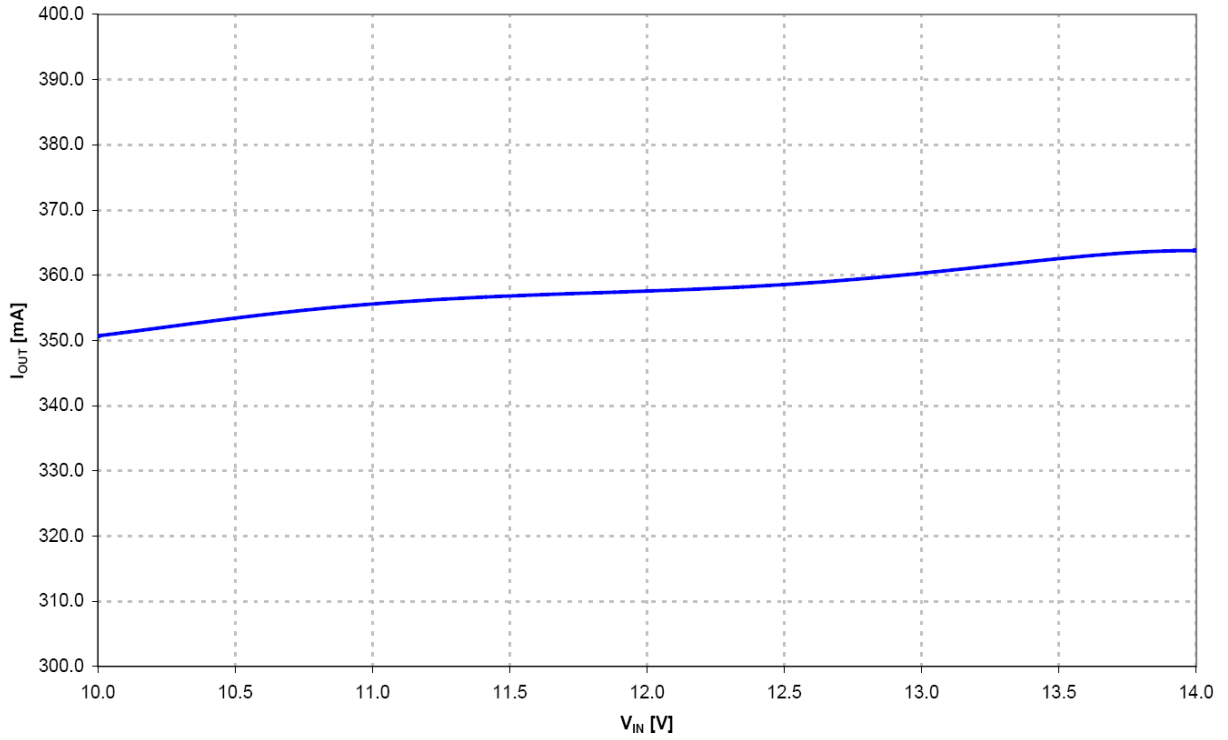


Figure 8 – Line regulation for  $V_{IN} = 12V_{dc}$ ,  $I_{OUT} = 350\text{ mA}$

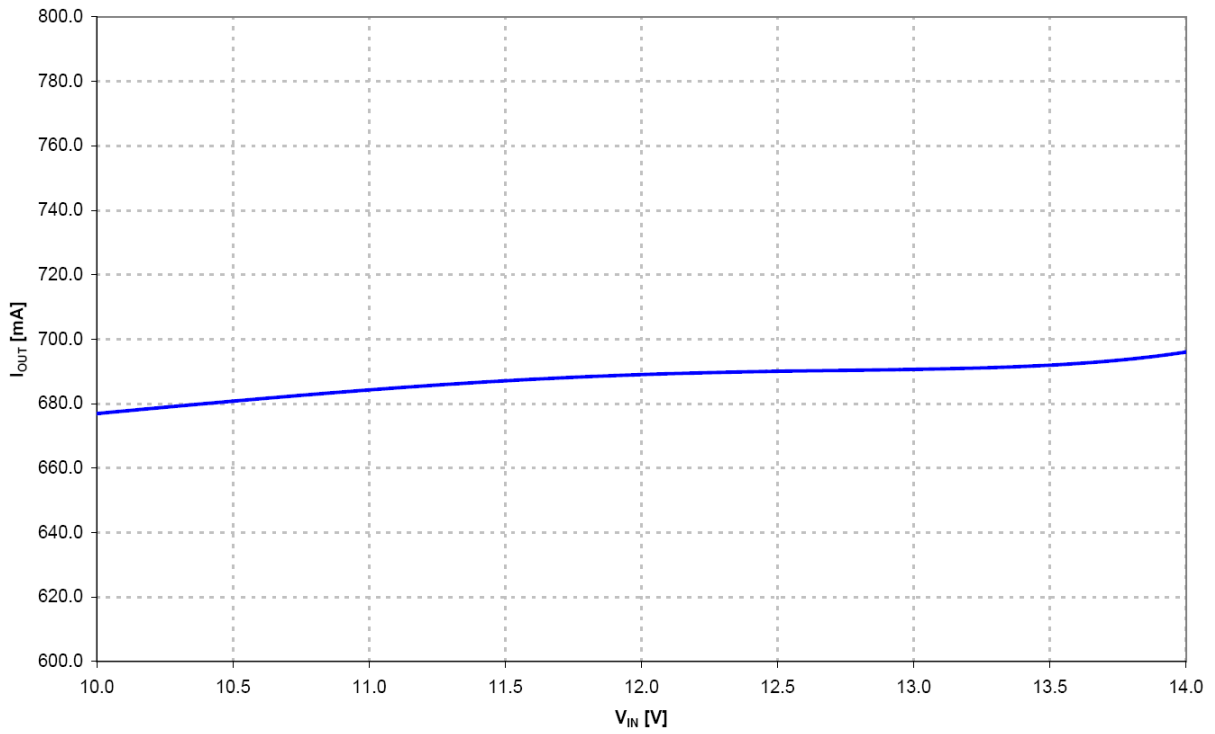
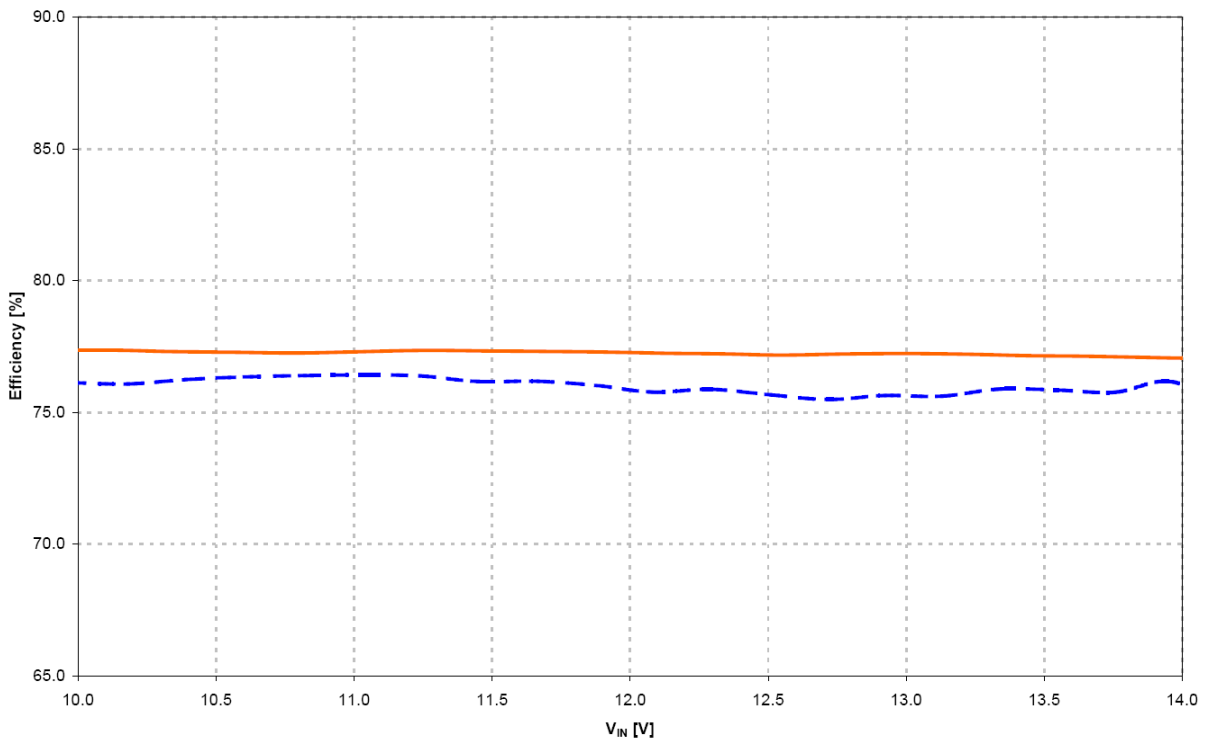
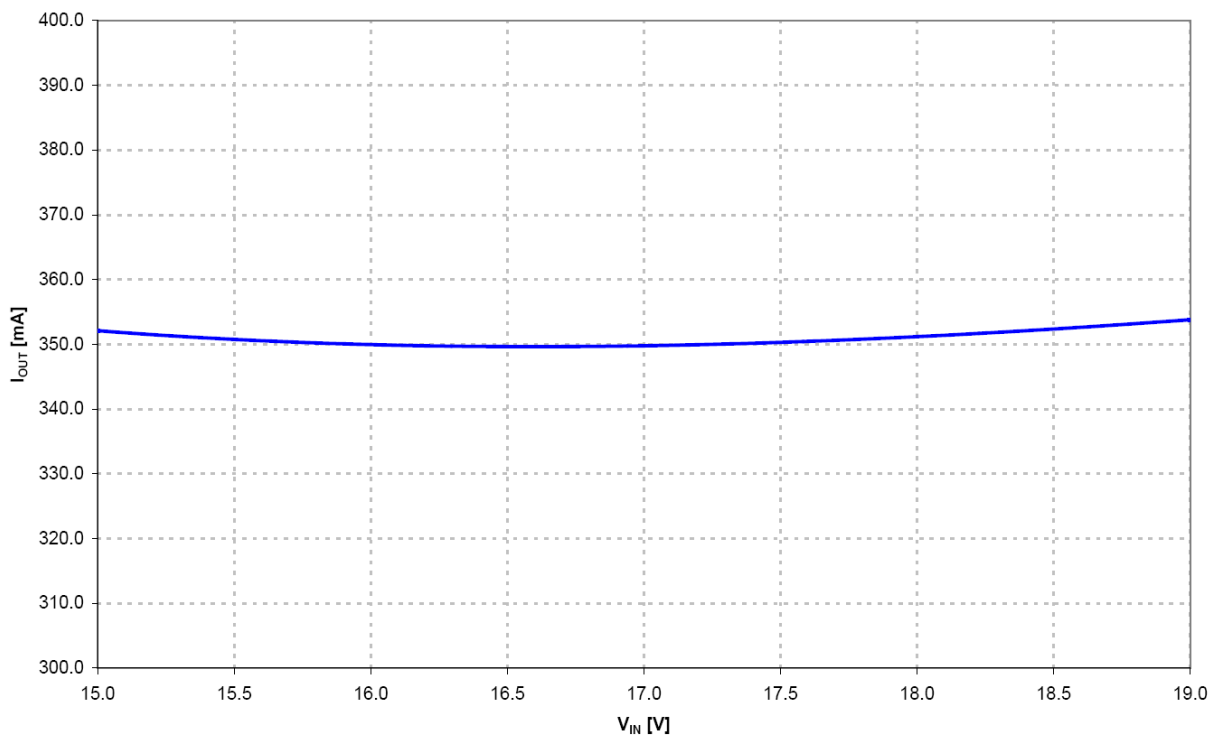


Figure 9 – Line regulation for  $V_{IN} = 12V_{dc}$ ,  $I_{OUT} = 700\text{ mA}$

# DN06033/D



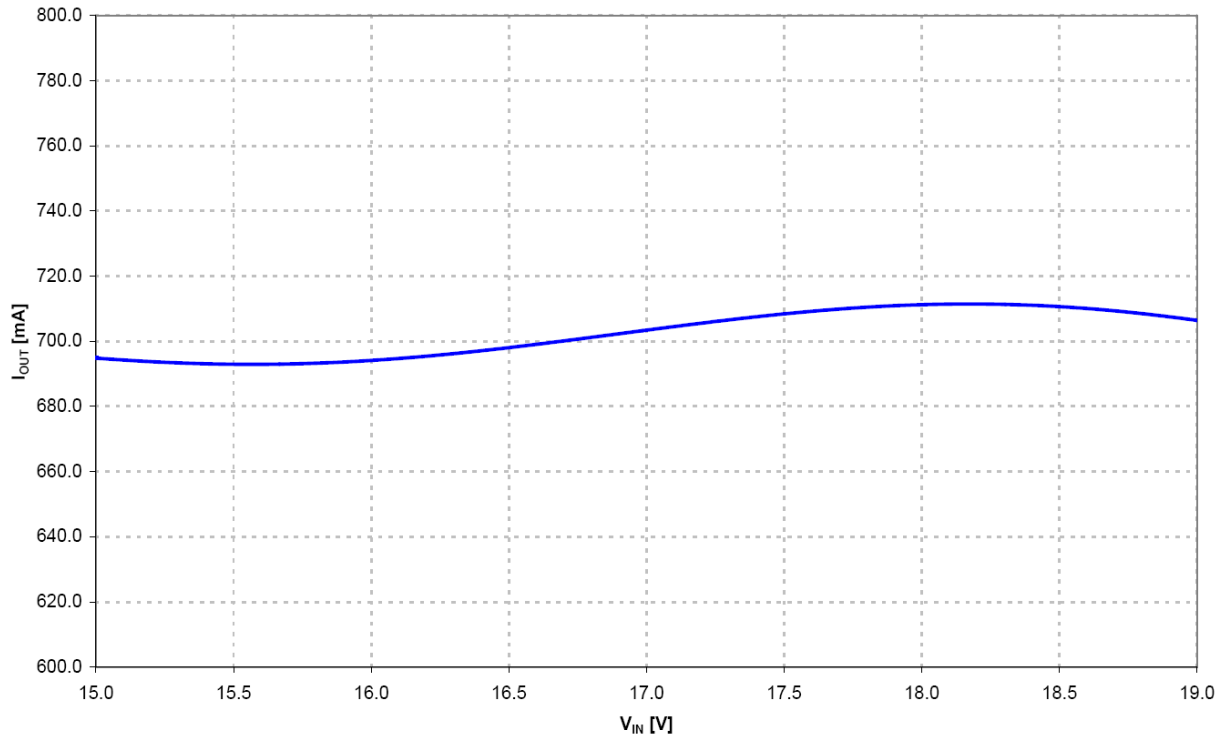
**Figure 10** – Efficiency for V<sub>IN</sub> = 12V<sub>dc</sub>, I<sub>OUT</sub> = 350mA and 700 mA



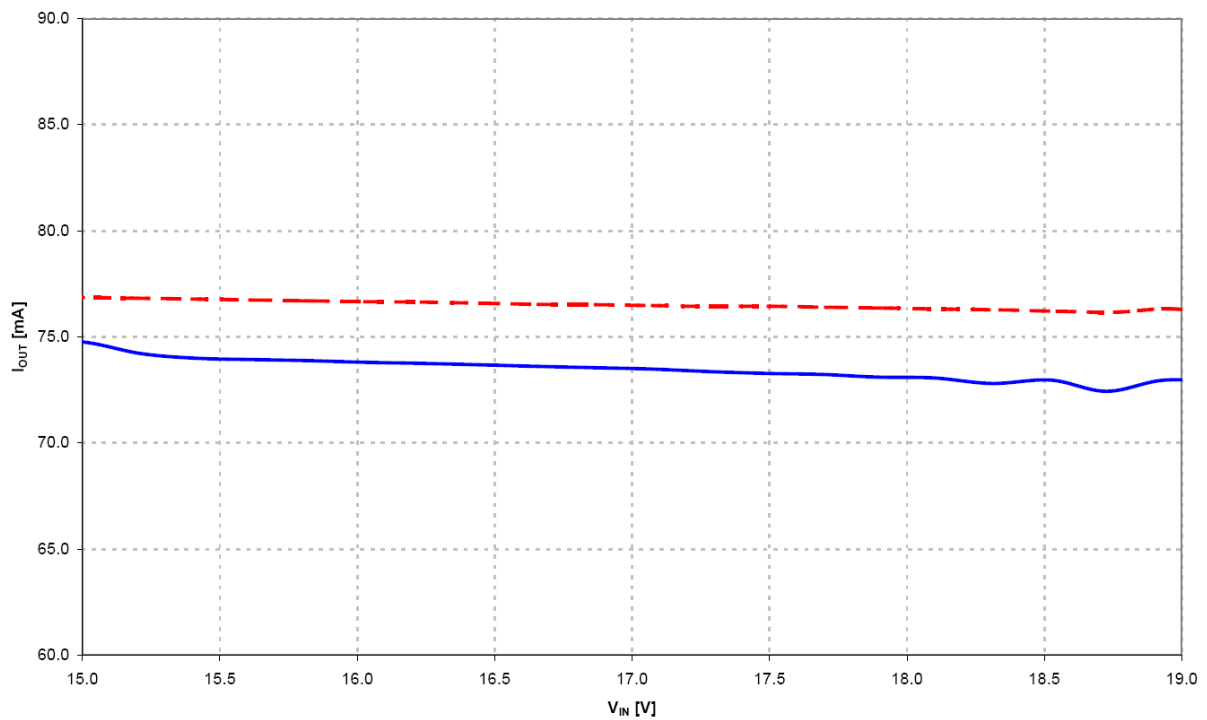
**Figure 11** – Line regulation for V<sub>IN</sub> = 12V<sub>ac</sub>, I<sub>OUT</sub> = 350 mA



### DN06033/D

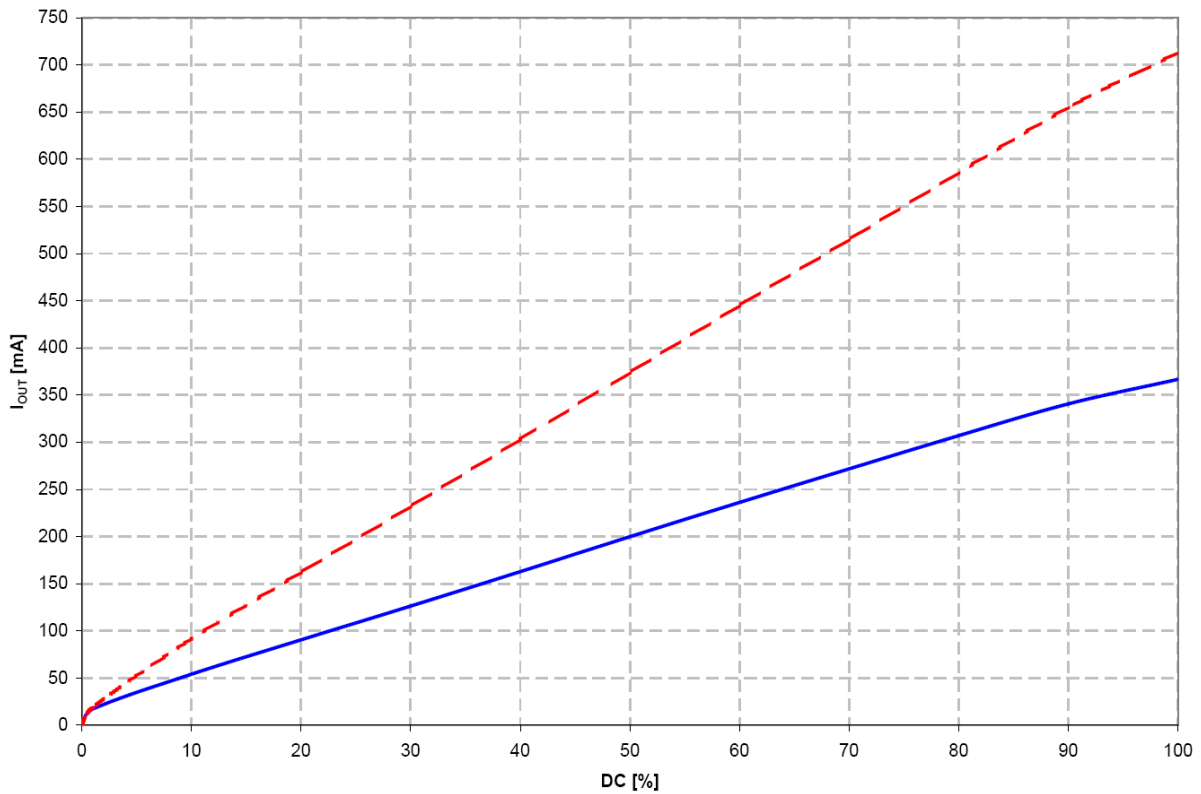


**Figure 12** – Line regulation for  $V_{IN} = 12V_{ac}$ ,  $I_{OUT} = 700$  mA



**Figure 13** – Efficiency for  $V_{IN} = 12V_{ac}$ ,  $I_{OUT} = 350$  mA and 700 mA

## DN06033/D



**Figure 14** – Dimming linearity, dimm.frequency 200Hz

© 2007 ON Semiconductor.

**Disclaimer:** ON Semiconductor is providing this design note "AS IS" and does not assume any liability arising from its use; nor does ON Semiconductor convey any license to its or any third party's intellectual property rights. This document is provided only to assist customers in evaluation of the referenced circuit implementation and the recipient assumes all liability and risk associated with its use, including, but not limited to, compliance with all regulatory standards. ON Semiconductor may change any of its products at any time, without notice.

*Design note created by Petr Konvicny, e-mail: petr.konvicny@onsemi.com*