



ON Semiconductor

DN05088/D

Design Note – DN05088/D

Dimmable, 9.5 W, 120 Vac CCR Lighting Circuit

Application	Input Voltage	Topology	Efficiency	Input Power	Power Factor	THD
LED Lighting, AC	110 to 130 Vac	Parallel-to-Series	80%	9.6 W	0.97	18.2%

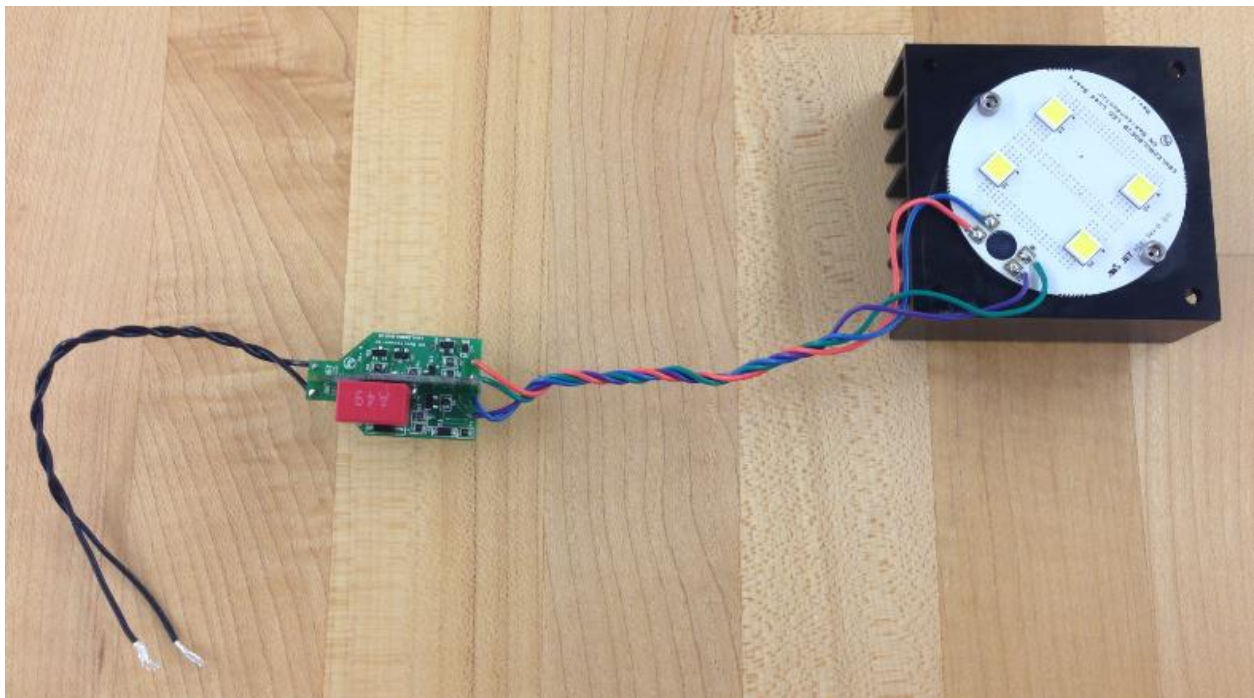

Figure 1 – Evaluation board with heat sink for LEDs.

Key Features

- All the LEDs are equally bright, so LEDs can be distributed apart from each other such as in a T8 tube
- Dimmable with standard Triac dimmers without wasteful active bleeding
- Power factor = 0.97
- THD below 20%
- Adjustable for different total LED voltages between 135 and 145 volts by changing a single resistor (R3)
- Thermal foldback; regulated current decreases as temperature increases
- Temperature compensated control circuitry
- Tested and proven from -40 °C to 85 °C in temperature chamber with minimal input power variation

DN05088/D Schematic

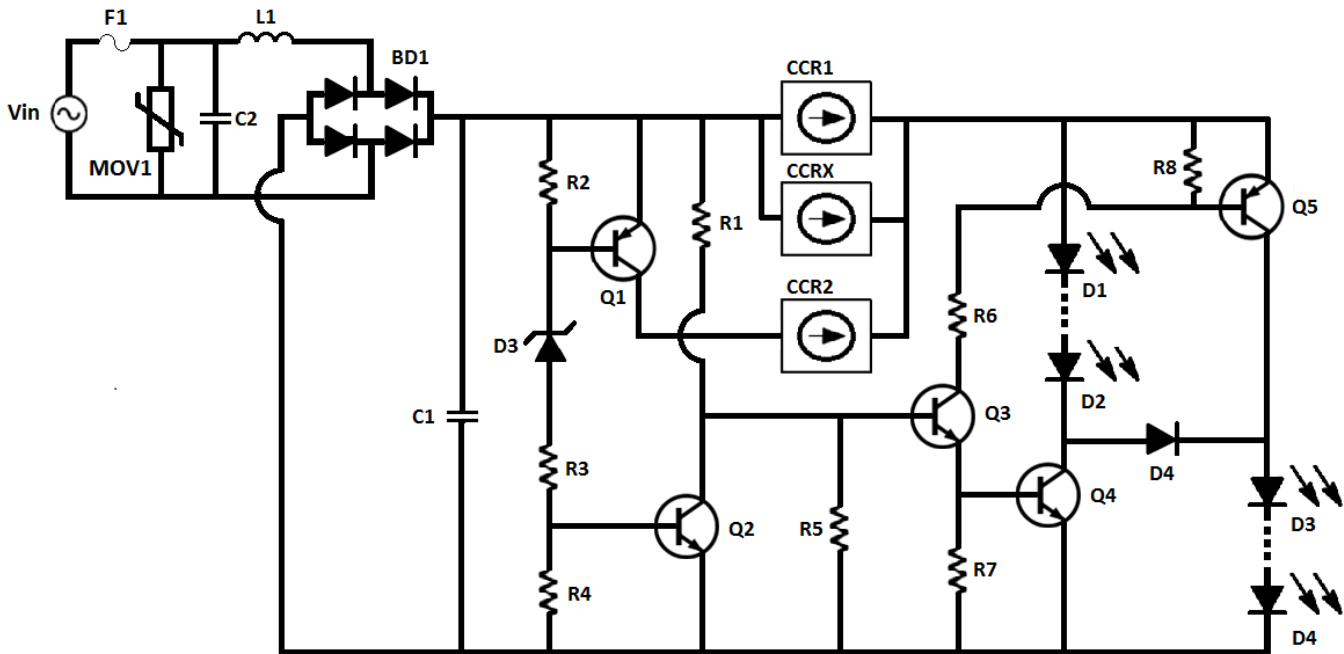

Figure 2 – Two-Stage Parallel-to-Series LED Lighting Circuit, with Switch-In CCR. It is possible to mount for an inductor (L1) and an additional capacitor on the board for additional EMI filtering, but generally these are not needed and L1 has a 0 ohm resistor in its place on the evaluation board. C2 may also be populated to ensure compatibility with a small minority of dimmers which require bleeding current even when manually switched off.

Circuit Operation

This circuit is an enhanced parallel-to-series LED lighting circuit. It uses updated control circuitry that allows the ability to accommodate multiple LED voltages by simply adjusting a single resistor (R3) as well as compensating for drift in LED voltage with temperature. It also has superb PF and THD performance, dimmability, low cost, and efficiency.

This circuit uses a parallel-to-series topology that dynamically adjusts LED load voltage as the instantaneous bridge output voltage varies. While a switch-mode power supply such as a buck converter reconfigures the input voltage to match the load, this circuit reconfigures the load to match the input voltage. When the instantaneous input voltage is relatively low, the LEDs are configured in parallel. When the instantaneous input voltage is relatively high, the LEDs are configured in series.

The circuit is designed for input voltages between 100 V_{AC} and 140 V_{AC} . ON Semiconductor CCRs are used to provide constant LED current and to protect LEDs from over-voltage conditions. The circuit employs an additional CCR (shown as CCR2) to increase LED current at high voltages for improved efficiency, PF, and THD performance.

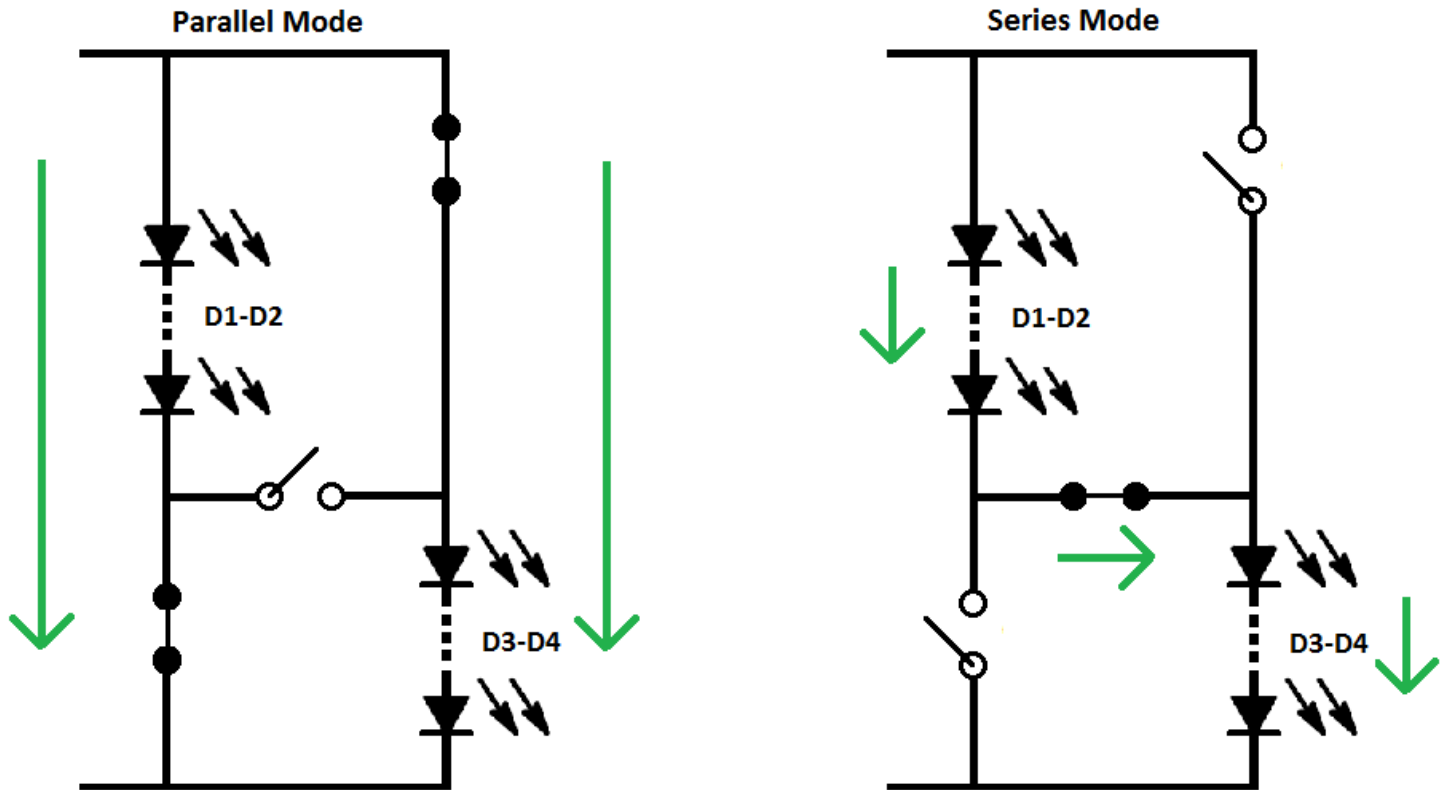

Figure 3 – The LED configuration is dynamically adjusted by the control circuitry. When AC instantaneous voltage is relatively low, the LEDs are configured in parallel. At relatively high AC instantaneous voltages the LEDs run in series.

How to Adjust the Driver for Different LEDs

For demonstration purposes, this circuit is configured with four LEDs that have a nominal forward voltage of 36 V. The recommended range for the total voltage of all LEDs combined for this type of circuit is 135 to 145 V. This range is approximate but will allow for the best efficiency and dimmability.

Use an oscilloscope to probe the voltage across CCR1 and CCRX. CCR1 and CCR3 should run with their anode-cathode voltage (VAK) at 3 to 6 volts as the LEDs switch from parallel-to-series. Make slight adjustments to R3 to accomplish this. For example, the typical value for R3 will be 52.3k, but a certain LED may require 47k for R3. If the CCR1 and CCRX voltage is too high when the strings switch their configuration, the circuit will be less efficient. If CCR1 and CCRX VAK is too low then efficiency will improve but some TRIAC dimmers may misfire.

The base-emitter voltage at Q2 initiates the switch from parallel-to-series. This base-emitter voltage is about 0.6 V. The total LED voltage of the six 24 V Cree LEDs in this circuit was about 142 V. R3, R4, D3, and Q2 set the switching point.

$$V_{SWITCH(Q2)} = V_{BE(Sat)} \left(\frac{R3+R4}{R4} \right) = 0.6 \left(\frac{52.3k+374}{374} \right) = 85 \text{ V}$$

The contribution from D3 is about 62 V, and the contribution from R3, R4, and Q2 is about 85 V. Therefore the approximate switching point is 62 + 85 V = 147 V.

So to adjust for a lower LED voltage such as 138 V, adjust R3 lower.

$$V_{SWITCH(Q2)} = V_{BE(Sat)} \left(\frac{R3+R4}{R4} \right) = 0.6 \left(\frac{47k+374}{374} \right) = 76 \text{ V}$$

These calculations make assumptions such as a constant and precisely measured LED voltage, so be sure to verify with an oscilloscope that CCR1 has VAK between 3 to 6 V at the switching point. Use Table 1 as a reference for starting values of R3.

Please note that higher LED voltages provide better efficiency.

Table 1. Suggested starting values for R3 to tune the circuit for different LED voltages.

Total LED Voltage for all LEDs in Series	Suggested starting value for R3 (verify CCR1 Vak with oscilloscope)
136 V	47.6 kΩ
138 V	48.9 kΩ
140 V	50.1 kΩ
142 V	51.4 kΩ
144 V	52.3 kΩ

Also be sure that CCR3 is active just above the switching point. R3 can be manipulated for this purpose if necessary. If CCR3 is on for too long, THD will improve but efficiency will decrease slightly. To tune this, decrease the value of R2 in 5 or 10% increments.

If CCR3 is not on for long enough, THD and efficiency will suffer. Increase the value of R2 in 5 or 10% increments to correct this.

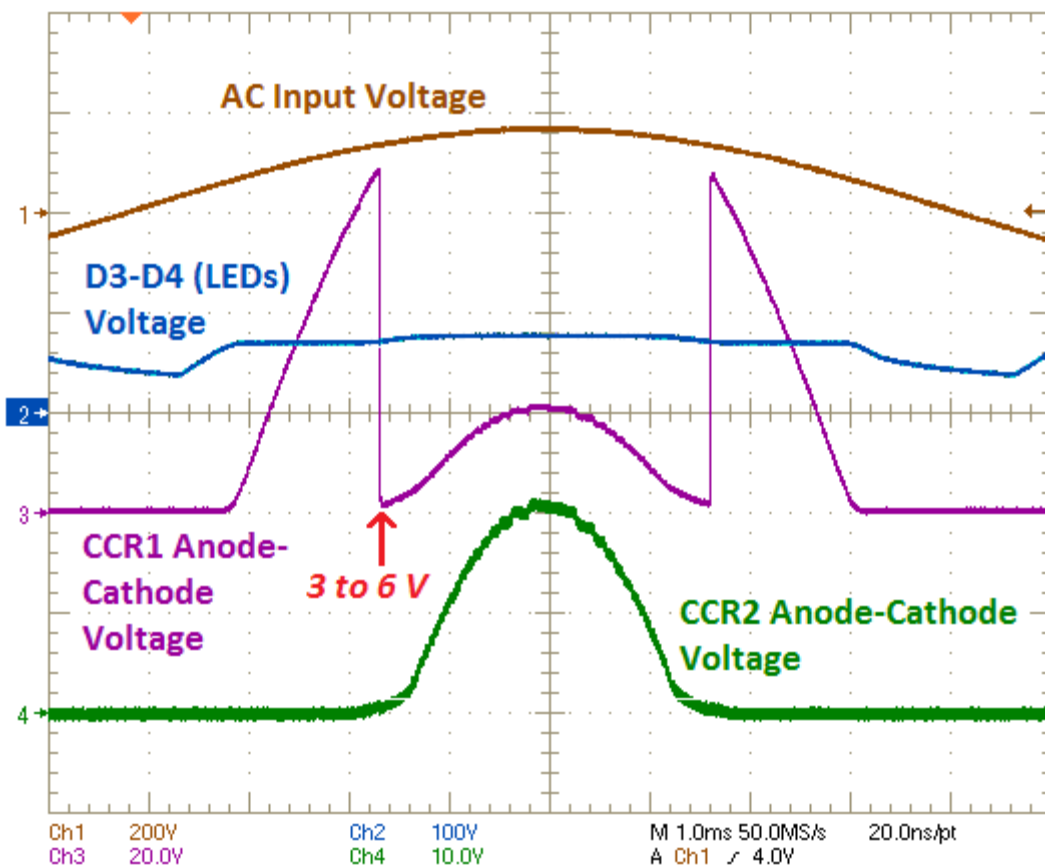

Figure 4 – When adjusting for different LEDs, choose R3 such that CCR1 has 3 to 6 V across it at the point the red arrow indicates in the figure. This point is where the LEDs switch from parallel to series. While this switch takes place the CCRs must continue conducting so allow for them to have 3 to 6 V.

Populating L1 and C2

The evaluation board is shipped with L1 shorted as a 0 ohm resistor and C2 populated with an X2 film capacitor. L1 and C2 form an EMI filter. Generally EMI filtering is not needed with these circuits because they are not switching power supplies.

Using C2 has several advantages and disadvantages. The advantages are increased EMI filtering and surge protection, but these are not really needed for most applications. Also it ensures compatibility with some dimmers that require a leakage path to maintain the LEDs in the off state when the dimmer's manual switch is turned off. Another way to provide this leakage is with a resistor, but that would decrease efficiency. We recommend testing with and without C2 and checking whether the circuit satisfies whatever requirements are being sought for a particular lamp. The disadvantages to C2 are the size, cost, and extra population step.

Circuit Performance Data (with small heat sink attached to LEDs)

Specification	110 V _{AC}	120 V _{AC}	130 V _{AC}
I _{RMS(out)} (mA)	58	70	76
Power Factor	0.968	0.975	0.978
THD _{Total} (I _{RMS} , %)	21.7	18.2	15.7
P _{IN} (W)	7.95	9.6	10.9
Efficiency (%)	77.6	80.1	78.2

DN05088/D
Bill of Materials

Designator	Quantity	Description	Value	Tolerance	Footprint	Manufacturer	Manufacturer Part Number	Substitution Allowed
R1	1	Resistor SMD	510k, 1/8th W	5%	0805	Any	Any	Yes
R2	1	Resistor SMD	422, 1/8th W	1%	0805	Any	Any	Yes
R3	1	Resistor SMD	52.3k, 1/8th W	1%	0805	Any	Any	Yes
R4	1	Resistor SMD	374, 1/8th W	1%	0805	Any	Any	Yes
R5	1	Resistor SMD	10k, 1/8th W	5%	0805	Any	Any	Yes
R6	1	Resistor SMD	51k, 1/8th W	5%	0805	Any	Any	Yes
R7, R8	2	Resistor SMD	100k, 1/8th W	5%	0805	Any	Any	Yes
C1	1	Capacitor SMD	10nF, 500 V	20%	0805	Any	Any	Yes
C2	1	X2 Film Capacitor	220 nF, 275 VAC	10%	Through Hole	Wurth Electronics Inc	890324023028	Yes
BD1	1	Bridge Rectifier	600 V	N/A	TO-269AA	Vishay	MB6S-E3/80	Yes
D3	1	Diode SMD	62 Vz	5%	SOD-123	ON Semiconductor	MMSZ5265BT1G	No
D4	1	Diode SMD	250 V	N/A	SOD-323	ON Semiconductor	BAS21HT1G	No
LED Board D1-D4	4	SMD LED	36V	N/A	SMD	Cree	MHBAWT-0000-000N0BD265E	No
Q1	1	PNP Bipolar Transistor SMD	N/A	N/A	SOT-23	ON Semiconductor	MMBTA56LT1G	No
Q2	1	NPN Bipolar Transistor SMD	N/A	N/A	SOT-23	ON Semiconductor	MMBT3904LT1G	No
Q3	1	NPN Bipolar Transistor SMD	N/A	N/A	SOT-23	ON Semiconductor	MMBT6517LT1G	No
Q4	1	NPN Bipolar Transistor SMD	N/A	N/A	SOT-23	ON Semiconductor	NSS1C201LT1G	No
Q5	1	PNP Bipolar Transistor SMD	N/A	N/A	SOT-23	ON Semiconductor	NSS1C200LT1G	No
CCR1	1	Constant Current Regulator SMD	120V, 30mA	15%	SMB	ON Semiconductor	NSIC2030JB	No
CCR2, CCRX	2	Constant Current Regulator SMD	120V, 50mA	15%	SMB	ON Semiconductor	NSIC2050JB	No
F1	1	Fuse SMD	1.5A, 250V	N/A	2-SMD	Littelfuse	044301.5DR	Yes
MOV1	1	Varistor SMD	198V, 250A	N/A	2-SMD	Littelfuse	V220CH8T	Yes
L1	1	Resistor SMD	0, 1/8th W	NA	0805	Any	Any	Yes

Compatible with Triac Dimmers

This circuit is inherently compatible with triac dimmers. The LEDs run for a large portion of time and the sinusoidal current draw resembles that of an incandescent bulb. In the ON Semiconductor lab the circuit was tested with the dimmers below and found to be fully functional. Populate C2 to ensure compatibility with a small minority of dimmers which require bleeding current even when manually switched off.

Dimmers Tested

Manufacturer	Serial Number
Lutron	DVCL 153P
Lutron	DVWCL 153P
Lutron	CTCL 153P
Lutron	TECL 153P
Lutron	AYCL 153P
Lutron	5LL 153P
Lutron	LGCL 153P
Lutron	SCL-153P
Lutron	MACL 153MH
Leviton	IPL06-10Z
Leviton	6674 - POW
Leviton	1B410S
Legrand	WS703
Legrand	DCL453PTC

© 2016 ON Semiconductor.

Disclaimer: ON Semiconductor is providing this design note "AS IS" and does not assume any liability arising from its use; nor does ON Semiconductor convey any license to its or any third party's intellectual property rights. This document is provided only to assist customers in evaluation of the referenced circuit implementation and the recipient assumes all liability and risk associated with its use, including, but not limited to, compliance with all regulatory standards. ON Semiconductor may change any of its products at any time, without notice.

Design note created by Andrew Niles, Andrew Stemple, and Cody Campana.