



ON Semiconductor

Design Note – DN05047/D

230 Vac, Low-Cost, Dimmable, Three-Stage LED Driver

Device	Application	Topology	Efficiency	THD	Power Factor	Input Power
NSIC2020JB, NSIC2030JB	LED Lighting	Linear	78%	17%	0.99	15 W

Schematic

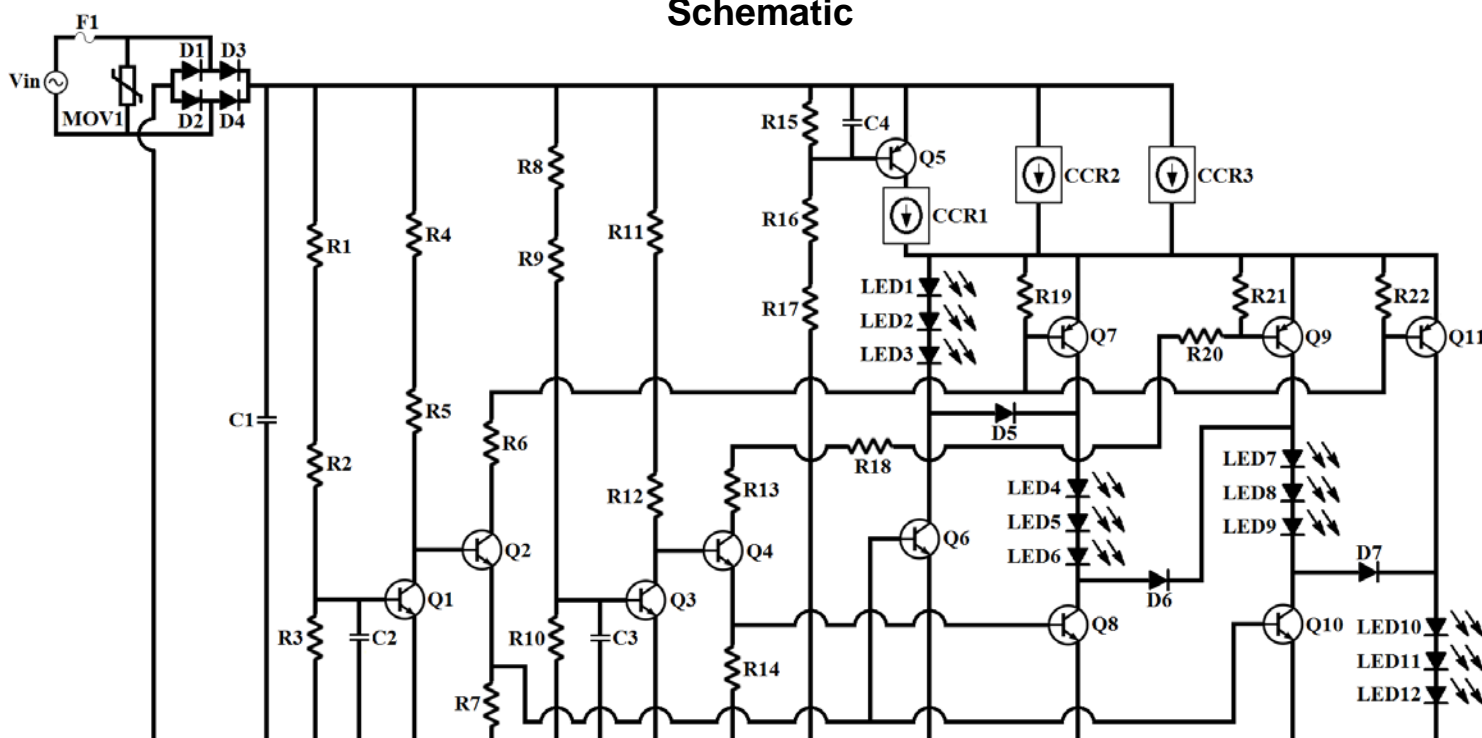

Figure 1: Three-Stage 230 Vac CCR lighting circuit

Overview

This circuit uses an innovative linear topology to meet and exceed the design requirements for LED lamps that operate on 230 Vac mains power. Its primary features are its low cost, phase-cut dimmability, compactness, high light output, efficiency, high power factor, and low THD. The circuit uses ON Semiconductor Constant Current Regulators (CCRs) to control the current through the LEDs and protect against overvoltage. The circuit is capable of operating at 50 or 60 Hz and at voltages from 80 to 255 Vac.

Circuit Description

The circuit consists of a full-wave bridge rectifier (D1-D4), threshold detection and switching circuitry (R1-R22, Q1-Q11, and D5-D7), four LED strings (LED1-LED3, LED4-LED6, LED7-LED9, and LED10-LED12), and three ON Semiconductor Constant Current Regulators (CCR1-CCR3).

Circuit Operation

The bridge rectifies the 230 Vac input providing a waveform with a peak voltage of 322 V. The bridge output is referenced from the cathodes of D3 and D4 to the anodes of D1 and D2.

Referring to Figures 2-6, it can be seen that the arrangement of the LED strings is adjusted through three distinct stages. The four strings of LEDs automatically adjust their configuration with each other depending on the bridge output voltage.

If the bridge output voltage is from 0 to 110 V, the circuit is in Stage 1 and the four strings are configured in parallel. Between 110 and 230 V, the circuit is in Stage 2 and the four strings are configured in a 2 x 2 parallel and series array. Stage 3 is when the bridge output voltage is greater than 230 V. In the third stage, all of the LEDs are in series.

The circuit uses voltage dividers in conjunction with the bridge output voltage to switch between the three stages. Q1 initiates the switching process between Stage 1 and Stage 2, and Q3 initiates the switching process between Stage 2 and Stage 3.

This circuit is configured to function with the LEDs having a forward voltage of about 56 V with 70 mA through them. This topology should be applied with LED strings with forward voltages between 55 and 60 V. The switching points between stages should be set so that the voltage across CCR2 and CCR3 is between 5 and 15 V when transitioning between stages. An example of this is the second waveform in Figure 9. Setting the switching points properly allows for high efficiency and prevents adverse effects such as flickering while dimming.

R3 and R10 may be adjusted to move the switching points. For example, the switching point for Q1, denoted $V_{SWITCH(Q1)}$ depends on R1, R2, R3 and the $V_{BE(Sat)}$ of Q1. This relationship is expressed by the following equation:

$$V_{SWITCH(Q1)} = V_{BE(Sat)} \left(\frac{R1 + R2 + R3}{R3} \right)$$

Q1 is an ON Semiconductor MMBT3904L. A typical $V_{BE(Sat)}$ value of Q1 at 25 °C is 0.68 V. With R1 = 560 kΩ, R2 = 442 kΩ, and R3 = 6.2 kΩ, V_{SWITCH} is at about 110 V.

A similar equation may be used for adjusting the switching point between Stage 2 and Stage 3:

$$V_{SWITCH(Q3)} = V_{BE(Sat)} \left(\frac{R8 + R9 + R10}{R10} \right)$$

Q3 is also an ON Semiconductor MMBT3904L. With R8 = 560 kΩ, R9 = 442 kΩ, and R10 = 2.94 kΩ, V_{SWITCH} is at about 230 V.

To achieve high power factor and low THD characteristics, it is important to match the input current waveform to the input voltage sine wave. The circuit in this design note does this by allowing more current to pass through the load in Stage 3. As the input voltage rises, Q5 turns on. When Q5 is on, CCR1 is in parallel with CCR2 and CCR3.

CCR1 and CCR2 are 20 mA CCRs and CCR3 is a 30 mA CCR. Therefore, the total current to the LEDs is about 50 mA in Stage 1 and Stage 2, and about 70 mA in Stage 3.

Testing has shown that THD may be minimized to 6.9% at 230 Vac by eliminating CCR2 and substituting an NSIC2050B (50 mA CCR) for CCR1. This more closely matches the input current waveform to the input voltage waveform. The only disadvantage to this configuration is that the linearity of the dimming may be adversely affected.

Input power and current may be raised or lowered by using different CCRs. ON Semiconductor NSIC2020B (20 mA), NSIC2030B (30 mA), and NSIC2050B (50 mA) are suitable for this application. Higher levels of current may require adjustments to resistors to provide higher base currents for the BJTs.

Circuit Data

	220 Vac	230 Vac	240 Vac
Input Frequency (Hz)	50	50	50
Power (W)	13.9	14.6	15.4
Input Current (mA _{rms})	64.0	64.3	64.7
Power Factor	0.985	0.986	0.987
Efficiency (%)	79.4	77.7	75.4
THD (%; Input I _{rms})	17.1	16.5	16.0

Table 1: Electrical Characteristics

Key Circuit Features

- Fully functional with standard phase-cut dimmers
- Extremely low cost
- Power factor = 0.99
- Input current THD = 17% (tunable to 6.9%)
- Efficiency = 78%
- Functional from 80 to 255 Vac
- Constant current and protection for LEDs
- Compact form factor

DN05047/D

Bill of Materials

Designator	Manufacturer	Part Number	Qty	Description	Value	Tolerance
C1	Any	-	1	Capacitor	2.2 nF, 500 V	-
C2-C4	Any	-	1	Capacitor	1.0 nF, 10 V	-
CCR1, CCR2	ON Semi	NSIC2020JB	2	Constant Current Regulator	120 V, 20 mA	±15%
CCR3	ON Semi	NSIC2030JB	1	Constant Current Regulator	120 V, 30 mA	±15%
D1-D4	ON Semi	MRA4007	4	Diode	1000 V, 1 A	-
D5, D7	ON Semi	BAS16H	2	Diode	75 V, 200 mA	-
D6	ON Semi	MRA4004	1	Diode	400 V, 1.0 A	-
F1	Any	-	1	Fuse	350 Vac, 1 A	-
LED1-LED12	Any	-	12	LED	20 V, 175 mA	-
MOV1	Any	-	1	Varistor	300 Vac	-
Q1, Q3	ON Semi	MMBT3904L	2	NPN Transistor	40 V, 200 mA	-
Q2, Q4, Q6, Q8	ON Semi	MMBT6517L	4	NPN Transistor	350 V, 100 mA	-
Q5	ON Semi	MMBT5401L	1	PNP Transistor	150 V, 500 mA	-
Q7, Q9, Q11	ON Semi	MMBT6520L	3	PNP Transistor	350 V, 500 mA	-
Q10	ON Semi	MMBT5550L	1	NPN Transistor	140 V, 600 mA	-
R1, R8	Any	-	2	Resistor	560 kΩ, 1/8 W	±1%
R2, R9	Any	-	2	Resistor	442 kΩ, 1/8 W	±1%
R3	Any	-	1	Resistor	6.2 kΩ, 1/8 W	±1%
R4, R5, R11, R12	Any	-	4	Resistor	150 kΩ, 1/8 W	±5%
R6	Any	-	1	Resistor	30 kΩ, 1/8 W	±5%
R7, R14, R19, R21, R22	Any	-	5	Resistor	2.2 kΩ, 1/8 W	±5%
R10	Any	-	1	Resistor	2.94 kΩ, 1/8 W	±1%
R13, R18, R20	Any	-	3	Resistor	10 kΩ, 1/8 W	±5%
R15	Any	-	1	Resistor	1.4 kΩ, 1/8 W	±1%
R16, R17	Any	-	2	Resistor	200 kΩ, 1/8 W	±1%

Table 2: Bill of Materials for the circuit shown in Figure 1.

Dimmers Tested

Dimmer
Clipsal 32V500
Clipsal KB31RD400
Legrand 99314
Legrand 99958
MK SX8501
Relco RTS65R
SCT Y-25082A

Table 3: The circuit was fully functional with each dimmer tested.

Representational Circuit Operation and Waveforms

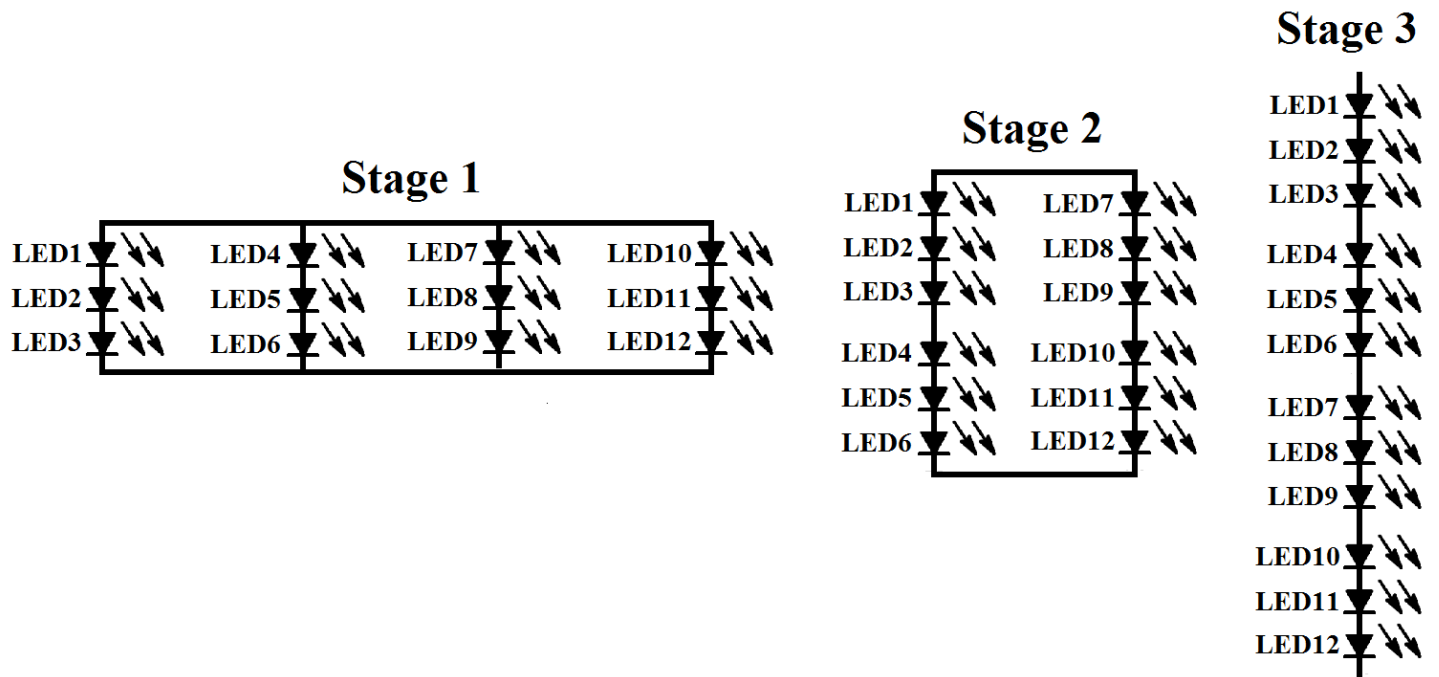

Figure 2: The LED strings alternate between three different configurations.

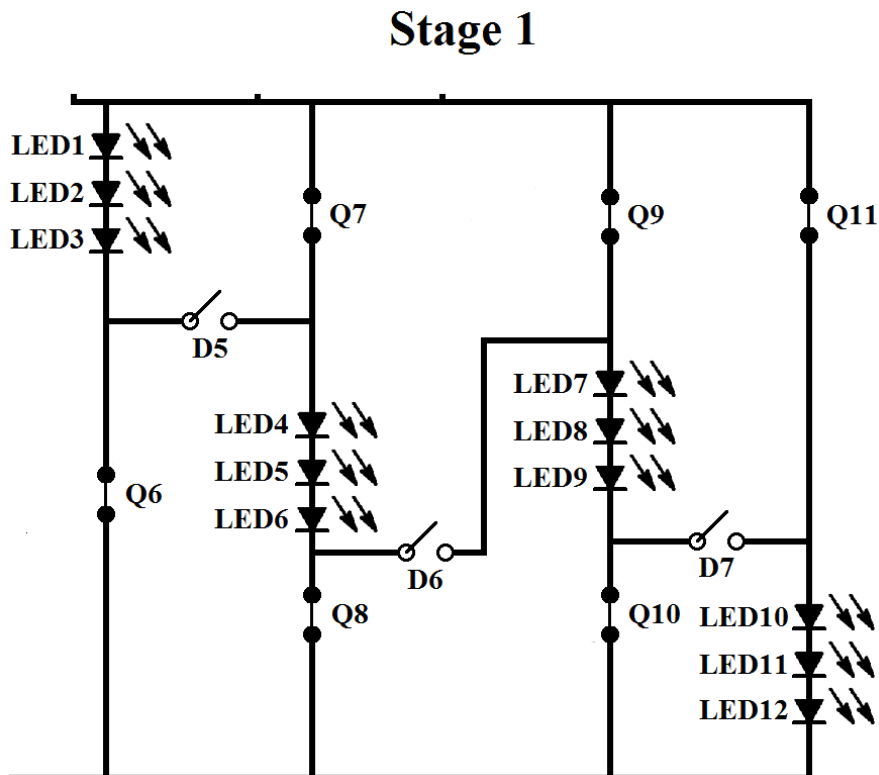

Figure 3: The circuit is in Stage 1 when the bridge output voltage is less than about 110 V. All four of the LED strings are in parallel in Stage 1.

Stage 2

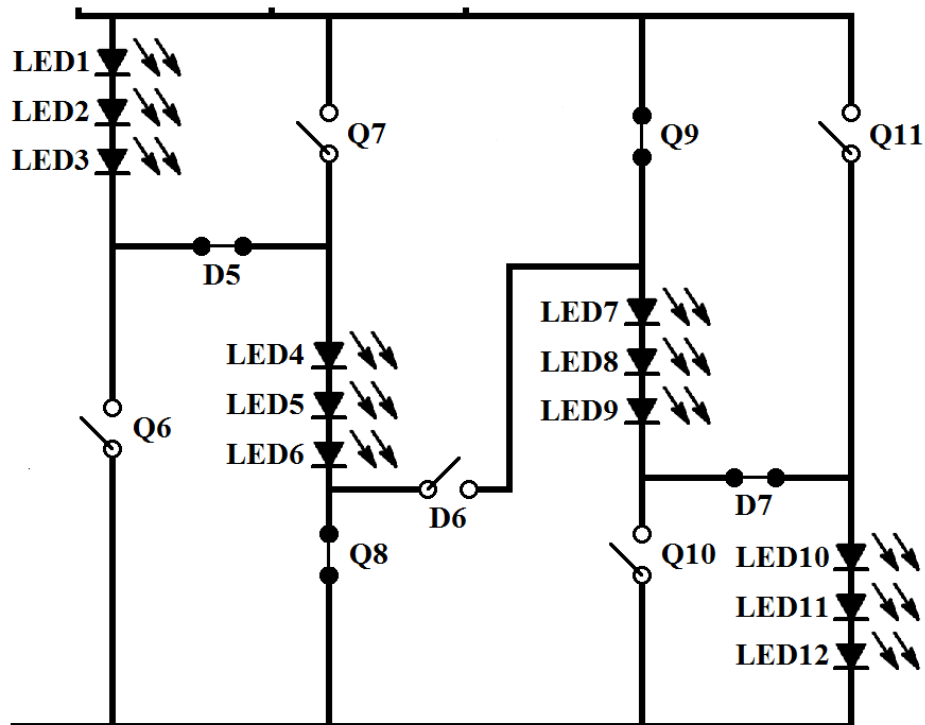

Figure 4: Stage 2 occurs when the bridge output voltage is between about 110 V and 230 V. In this stage, the LED strings are in a 2 x 2 array. In total, there are two parallel strings each consisting of six 20 V LEDs.

Stage 3

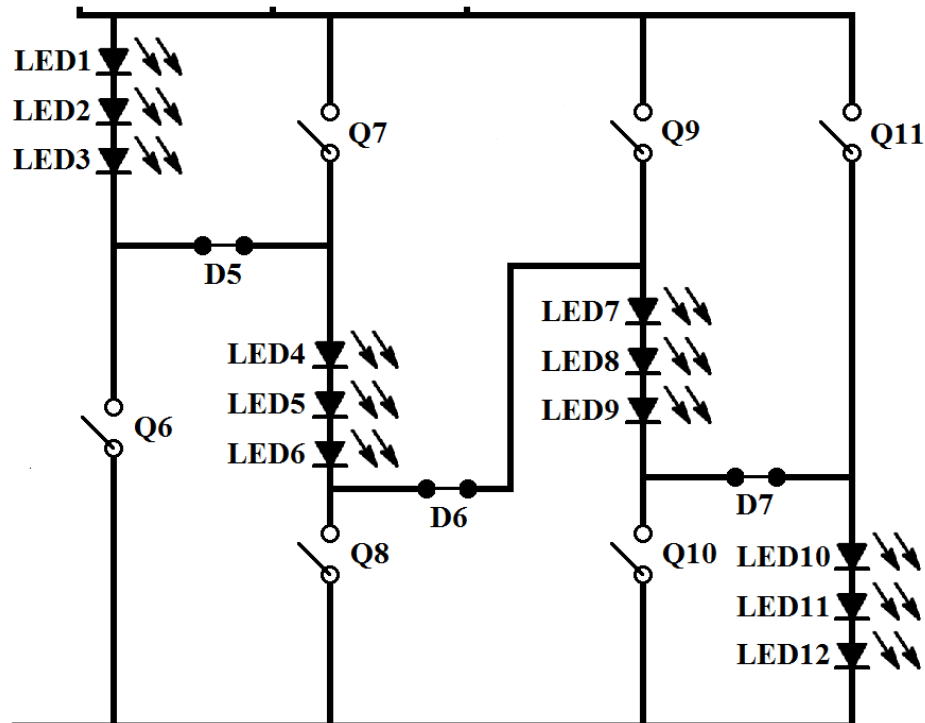

Figure 5: In Stage 3, all of the LEDs are in series. The circuit is in Stage 3 if the bridge output voltage is greater than approximately 230 V.

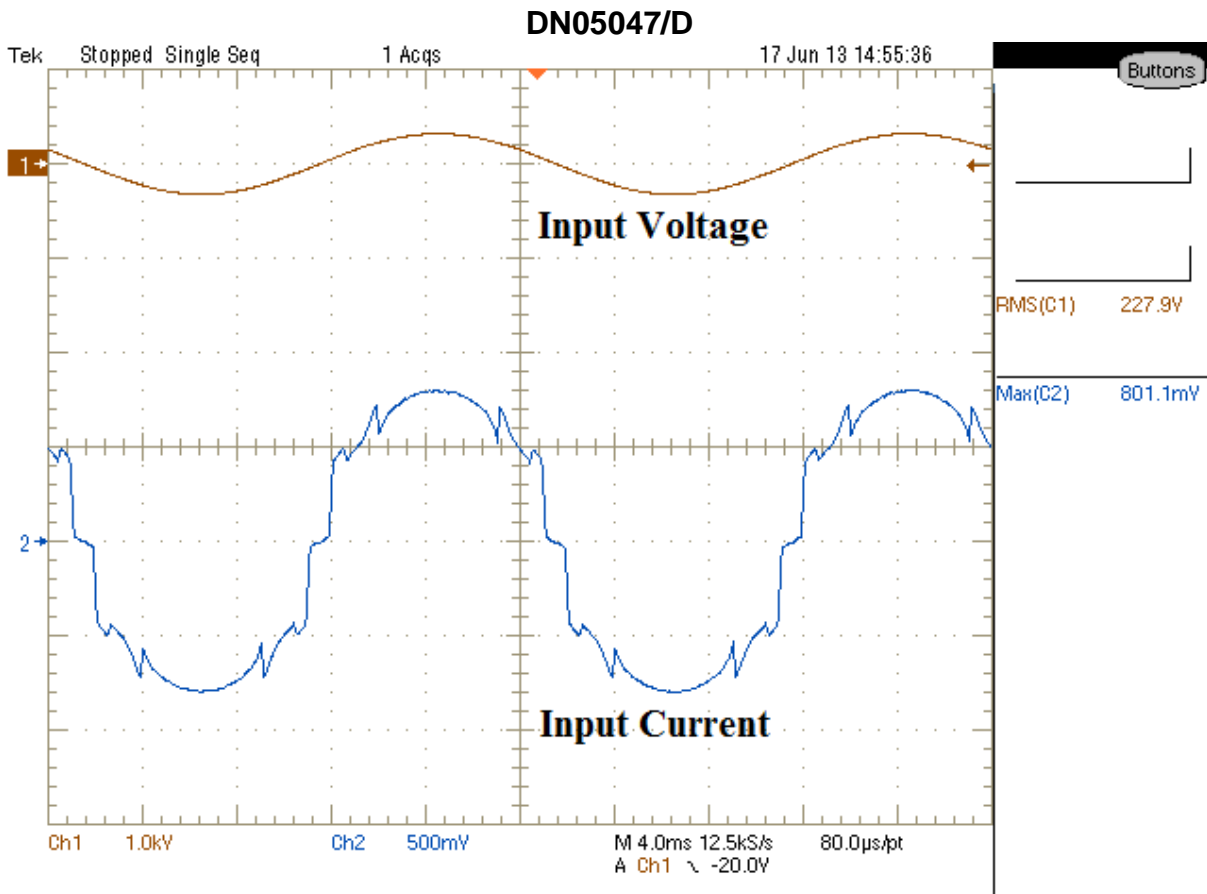

Figure 6: The total input current waveform is nearly sinusoidal, which provides excellent power factor and THD characteristics.

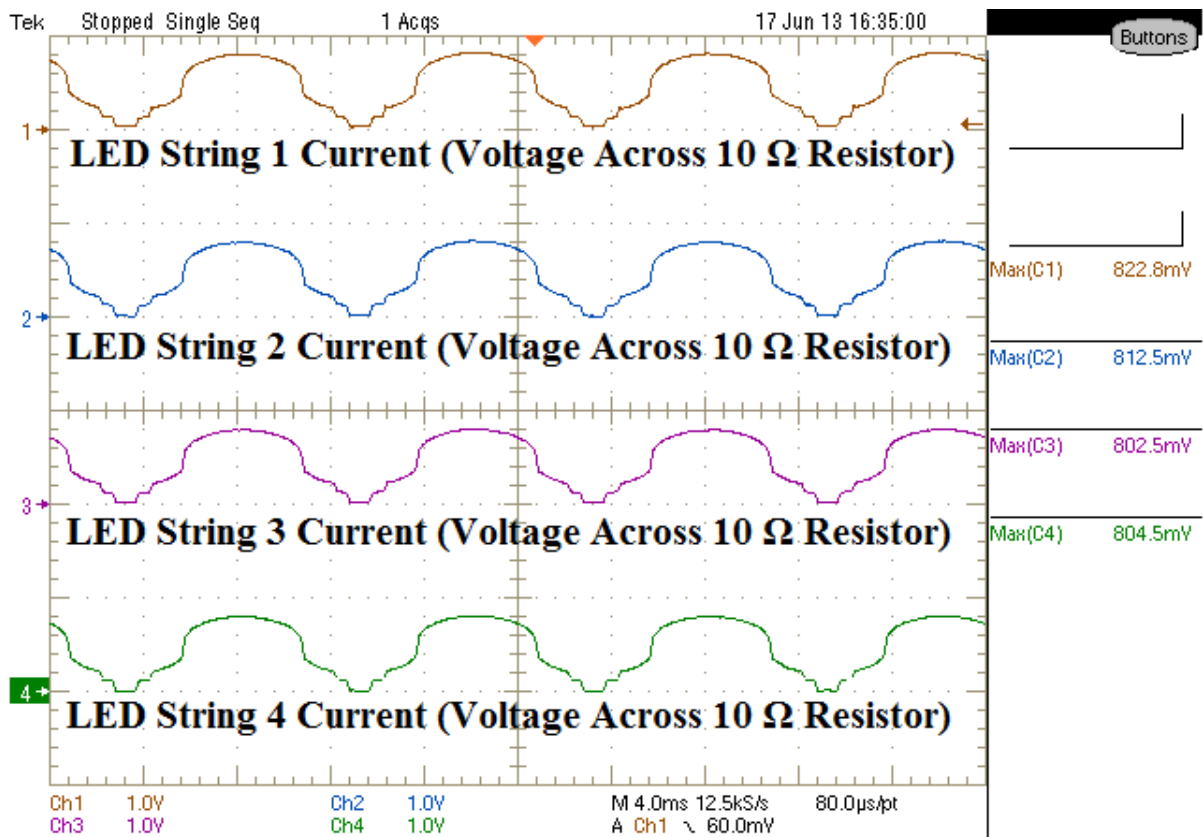

Figure 7: The LED current through each of the four strings is identical.

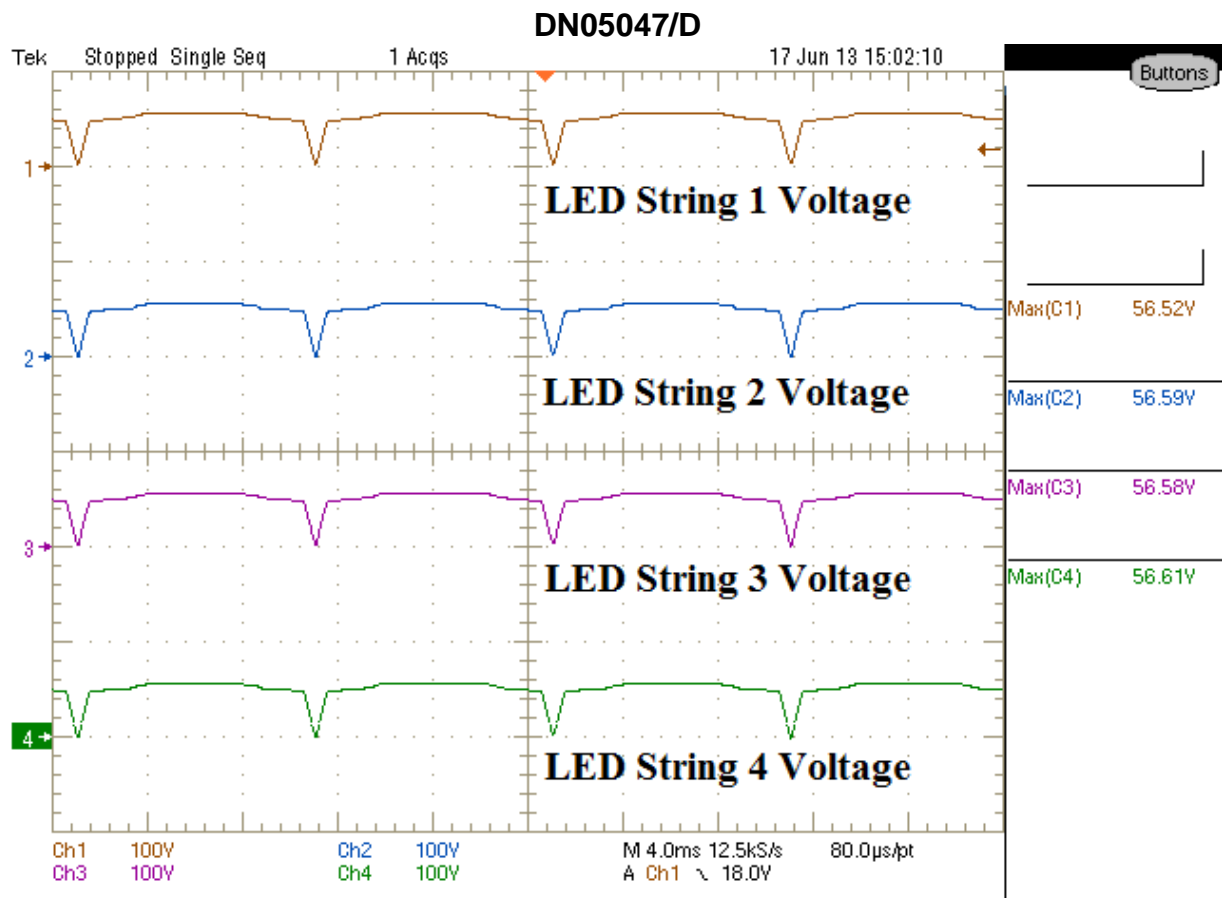

Figure 8: Each LED string receives the same voltage.

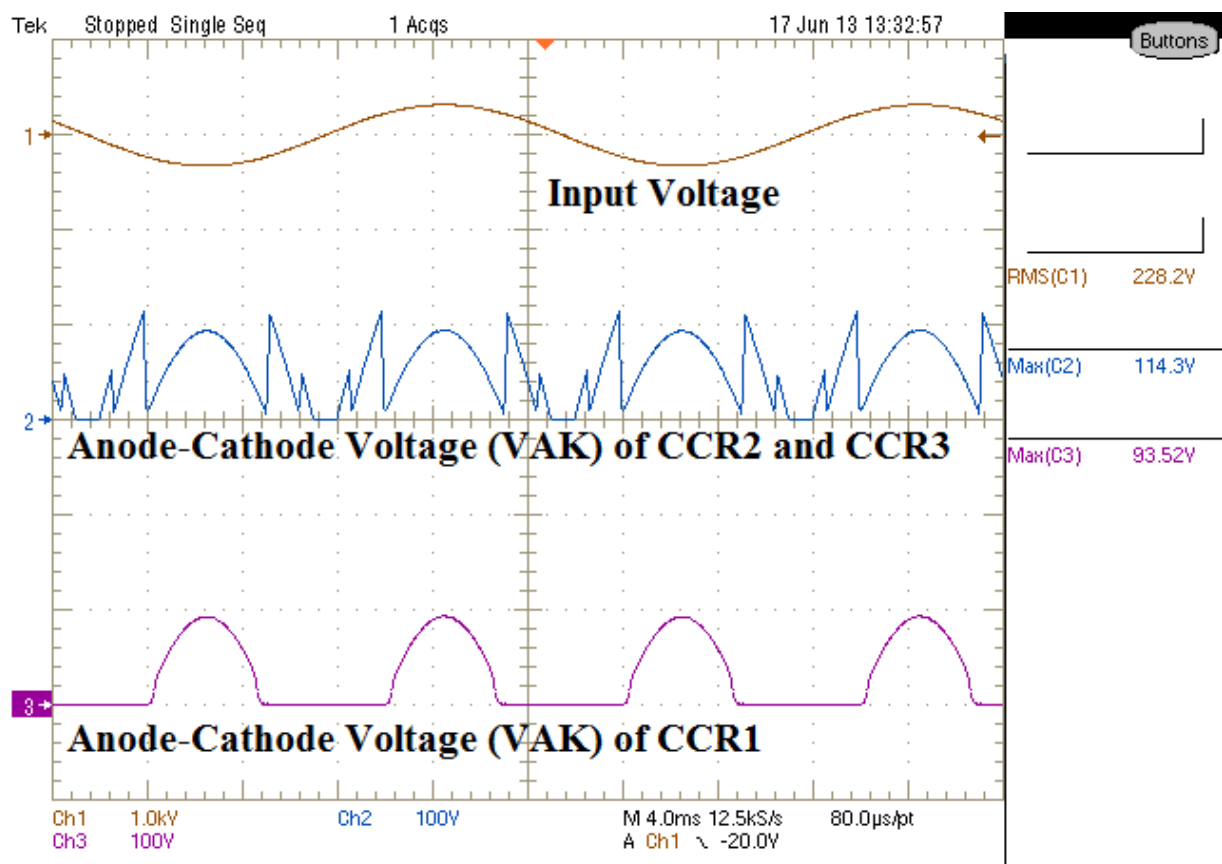

Figure 9: CCR1 conducts when the circuit is in Stage 3. CCR2 and CCR3 are on in all three stages.

DN05047/D

Evaluation Board

The evaluation kit CCR230PS3GEVK implements this circuit on metal-clad board, and includes both driver and LED boards, pictured in Figure 10. The driver board (top board) may be obtained singularly via the CCR230PS3AGEVB evaluation board.

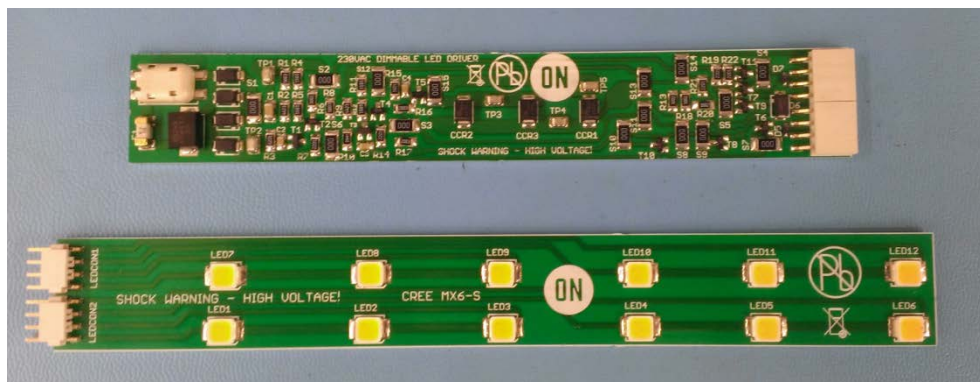

Figure 10: Contents of evaluation kit CCR230PS3GEVK.

If the user desires to use their own LEDs with the evaluation board, it should be noted that the off-board connections (in keeping with the design note's designators) are as follows:



Figure 11: Connections to map to off-board LEDs. The circuit will not function in all three stages if one or more strings are connected incorrectly or missing.

Further References

For a similar CCR LED lighting solution at 120V_{AC}, please refer to this design note:

- **Design Note – DN05051/D: 120 V_{AC}, Dimmable, Linear, 3-Stage, Parallel-to-Series LED Lighting Circuit**

http://www.onsemi.com/pub_link/Collateral/DN05051-D.PDF

© 2014 ON Semiconductor.

Disclaimer: ON Semiconductor is providing this design note “AS IS” and does not assume any liability arising from its use; nor does ON Semiconductor convey any license to its or any third party’s intellectual property rights. This document is provided only to assist customers in evaluation of the referenced circuit implementation and the recipient assumes all liability and risk associated with its use, including, but not limited to, compliance with all regulatory standards. ON Semiconductor may change any of its products at any time, without notice.

Design note created by Andrew Niles, e-mail: Andrew.Niles@ONsemi.com