

BelaSigna R261

Advanced Noise Reduction Solution for Voice Capture Devices

Introduction

BELASIGNA[®] R261 is a complete system-on-chip (SoC) solution that provides advanced dual-microphone noise reduction in voice capture applications such as laptops, mobile phones, webcams, tablet computers and other applications that will benefit from improved voice clarity.

Featuring a novel approach to removing mechanical, stationary and non-stationary noise, the chip preserves voice naturalness for greater speech intelligibility even when the talker is further away or not optimally aligned with microphones providing unmatched freedom of movement for end-users. Designed to be compatible with a wide range of codecs, baseband chips and microphones without the need for calibration, BelaSigna R261 is easy to integrate, improving manufacturers' speed to market.

Additional features include the ability to customize multiple voice capture modes and tune the algorithm to the unique needs of a manufacturer's device. The chip includes a highly optimized DSP-based application controller with industry-leading energy efficiency and is packaged in two highly compact 5.3 mm² WLCSPs to fit into even the most sized-constrained architectures and allow the use of the cheapest printed circuit board design technologies.

Key Features

- Advanced Two-Microphone Noise Reduction Algorithm
- Preserves Voice Naturalness
- Supports Close-Talk, Far-Talk and Custom Mode
- Conference Mode enables 360 Degrees Voice Pick-up
- Configurable Algorithm Performance
- Ultra Low Power Consumption
- Ultra Miniature Form Factor
- Complete System-on-Chip (SoC)
- Highly Flexible Clocking Architecture
- Hardware Configuration Interfaces
- Prototyping Tools
- These Devices are Pb-Free, Halogen Free/BFR Free and are RoHS Compliant

Typical Applications

- Notebook Computers
- Mobile Phones
- Tablet PCs
- Webcams
- Any Portable Audio Application with Voice Pick-up



ON Semiconductor[®]

<http://onsemi.com>

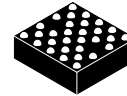

WLCSP-30
W SUFFIX
CASE 567CT

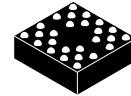

WLCSP-26
W SUFFIX
CASE 567CY

MARKING DIAGRAMS

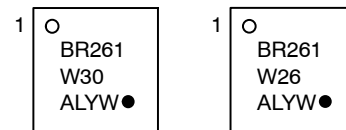

BR261 = BelaSigna R261
W30 = 30-ball version
W26 = 26-ball version
A = Assembly Location
L = Wafer Lot
YW = Date Code Year & Week
● = Pb-Free Package
○ = A1 Corner Indicator

ORIENTATION

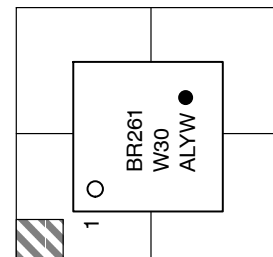

(Top View)

ORDERING INFORMATION

See detailed ordering and shipping information in the package dimensions section on page 31 of this data sheet.

BelaSigna R261

Table 1. ABSOLUTE MAXIMUM RATINGS

Parameter	Min	Max	Unit
Power Supply (Applies on VBAT, VBATRCVR and VDDO for "Max" and for VSSA, VSSRCVR and VSSD for "Min") (Note 1)	-0.3	4.0	V
Digital input pin voltage	VSSA - 0.3 V	VDDO + 0.3 V	V
Operating temperature range	-40	85	°C
Storage temperature range	-40	85	°C

Stresses exceeding Maximum Ratings may damage the device. Maximum Ratings are stress ratings only. Functional operation above the Recommended Operating Conditions is not implied. Extended exposure to stresses above the Recommended Operating Conditions may affect device reliability.

1. Time limit at maximum voltage must be less than 100 ms.

NOTE: Refer to ELECTRICAL CHARACTERISTICS and APPLICATION INFORMATION for Safe Operating Area.

This device series incorporates ESD protection and is tested by the following methods:

- ESD Human Body Model (HBM) tested per AEC-Q100-002 (EIA/JESD22-A114)
- ESD Machine Model (MM) tested per AEC-Q100-003 (EIA/JESD22-A115)

This device series incorporates latch-up immunity and is tested in accordance with JESD78:

Electrical Performance Specifications

Table 2. ELECTRICAL CHARACTERISTICS (The typical parameters in Table 2 were measured at 20°C with a clean 3.3 V supply voltage (unless noted differently). Parameters marked as screened are tested on each chip. Other parameters are qualified for all process corners but not tested on every part.)

Parameter	Symbol	Test Conditions / Notes	Min	Typ	Max	Unit	Screened
-----------	--------	-------------------------	-----	-----	-----	------	----------

OVERALL

Supply voltage	VBAT		1.8	3.3	3.63	V	
Maximum risetime		Between 0 V and 1.8 V			10	ms	
Average current consumption		Active mode, VBAT = 3.3 V	14	15	16	mA	
		Bypass mode, VBAT = 3.3 V		2.5		mA	
		Lineout mode, VBAT = 3.3 V		1.2		mA	
		Sleep mode, VBAT = 3.3 V	21	32	160	µA	
Peak active current		VBAT = 3.63 V		17	19	mA	

VREG (1 µF External Capacitor)

Output voltage	VREG	Without load, or with microphone attached (0 to 200 µA)	0.95	1.00	1.05	V	●
PSRR		@ 1 kHz	54			dB	
Load regulation		@ 2 mA		5	6	mV/mA	
Load current					2	mA	
Line regulation			-1		1	mV/V	

VDDA (1 µF External Capacitor on VDDA + 100 nF External Capacitor on CAP0/CAP1)

Output voltage	VDDA	Unloaded with VREG = 1 V	1.8	2.0	2.1	V	●
PSRR		@ 1 kHz	45			dB	
Load regulation		@ 1 mA		80	140	mV/mA	
Load current					1	mA	
Line regulation			-1		2	mV/V	

VDDD (1 µF External Capacitor)

Output voltage	VDDD		1.62	1.70	1.98	V	●
----------------	------	--	------	------	------	---	---

BelaSigna R261

Table 2. ELECTRICAL CHARACTERISTICS (continued) (The typical parameters in Table 2 were measured at 20°C with a clean 3.3 V supply voltage (unless noted differently). Parameters marked as screened are tested on each chip. Other parameters are qualified for all process corners but not tested on every part.)

Parameter	Symbol	Test Conditions / Notes	Min	Typ	Max	Unit	Screened
VMIC							
Output voltage		VMIC = VREG	0.95	1.00	1.05	V	●
		VMIC = VDDA	1.8	2.0	2.1	V	●
Load Regulation		VMIC = VREG		25	40	mV/mA	
		VMIC = VDDA		100	150	mV/mA	
POWER ON RESET							
POR Threshold		POR Release (VBAT going up)	1.52	1.60	1.71	V	●
		POR Activation (VBAT going down)	1.52	1.60	1.65	V	●
Boot Time		NRST to DMIC active using LSAD boot method		16		ms	
		NRST to DMIC active using EEPROM boot method (default custom application)		100		ms	
INPUT STAGE							
Sampling frequency		Defined by ROM-based application.		16		kHz	
Analog input voltage	V _{in}	No preamp gain on AI1 and AI3	0		2	V _{pp}	
	V _{in}	30 dB preamp gain by default on MIC0 and MIC2	0		63.25	mV _{pp}	
Preamplifier gain tolerance		1 kHz	-2		2	dB	
Input impedance	R _{in}	0 dB preamplifier gain, MCLK = 1.28 MHz	220		254	kΩ	
		All other gain settings	510		585	kΩ	●
		Line-Out	5.20		5.35	kΩ	
Input offset voltage		0 dB preamp gain			7	mV	
		All other gains			0.6	mV	
Channel cross coupling		Any 2 channels		-84	-60	dB	
Analog Filter cut-off frequency		LPF enabled	10	20	30	kHz	
		LPF disabled	50			kHz	
Analog Filter passband flatness			-1		1	dB	
Analog filter stopband attenuation			60			dB	
Digital Filter cut-off frequency				8		kHz	
Digital Filter cut-off stopband attenuation			80			dB	
Total Harmonic Distortion + Noise (Peak value)	THDN	30 dB preamplifier gain VBAT = 3.3 V	-64	-68		dB	
Dynamic Range	DR	30 dB preamplifier gain VBAT = 3.3 V	-77	-78		dB	
Equivalent Input Noise	EIN	30 dB preamplifier gain VBAT = 3.3 V		3		μV	

BelaSigna R261

Table 2. ELECTRICAL CHARACTERISTICS (The typical parameters in Table 2 were measured at 20°C with a clean 3.3 V supply voltage (unless noted differently). Parameters marked as screened are tested on each chip. Other parameters are qualified for all process corners but not tested on every part.)

Parameter	Symbol	Test Conditions / Notes	Min	Typ	Max	Unit	Screened
-----------	--------	-------------------------	-----	-----	-----	------	----------

DIGITAL MICROPHONE OUTPUT

DMIC input clock frequency		With presets 0 or 5 selected on CONFIG_SEL (Note 2)		2.048		MHz	
		With preset 1 selected on CONFIG_SEL (Note 2)		2.4		MHz	
		With preset 3 selected on CONFIG_SEL (Note 2)		2.8		MHz	
		With preset 2 selected on CONFIG_SEL (Note 2)		3.072		MHz	
Clock duty cycle		Any clock configuration	40	50	60	%	
Input clock jitter		Maximum allowed jitter on the DMIC_CLK			10	ns	
Clock to output transition time	DMIC_OUT		10	20	50	ns	

ANALOG OUTPUT STAGE

Signal Range	Vout	One single ended DAC used	0		2	Vpp	
		Two DACs used as one differential output	0		4	Vpp	
Attenuator gain tolerance			-2		2	dB	
Output impedance	Rout	@ 12 dB output attenuation			16	kΩ	●
		@ 0 dB output attenuation			3	kΩ	
Channel cross coupling					-65	dB	
Analog Filter cut-off frequency		LPF Enabled	13.0		13.5	kHz	
		LPF Disabled	25		26	kHz	
Analog Filter passband flatness			-1		1	dB	
Analog filter stopband attenuation		> 60 kHz	90			dB	
Digital Filter cut-off frequency				8		kHz	
Digital Filter cut-off stopband attenuation			80			dB	
Total Harmonic Distortion + Noise (Peak value)	THDN		-62	-68		dB	●
Dynamic Range	DR		-74	-83		dB	●
Noise Floor				70	100	μV	●

DIRECT DIGITAL OUTPUT (available only through custom mode)

Supply voltage	VBATRCVR		1.8	3.3	3.6	V	
Signal Range	Vout	One Differential Output Driver used @ 1 kHz	0		2*VBATRCVR	Vpp	
		Single ended Output Driver used @ 1 kHz	0		VBATRCVR	Vpp	
Output Impedance	Rout	Load between 1 mA and 30 mA @ 0°C			4	Ω	
Maximum Current					90	mA	
Total Harmonic Distortion + Noise (Peak value)	THDN		-67	-71		dB	●

2. Many other clock frequencies are available through custom configuration of the internal PLL and clocking subsystem. See later in this document and in the BelaSigna R261 Configuration and Communications Guide for more information on custom mode usage.

BelaSigna R261

Table 2. ELECTRICAL CHARACTERISTICS (continued) (The typical parameters in Table 2 were measured at 20°C with a clean 3.3 V supply voltage (unless noted differently). Parameters marked as screened are tested on each chip. Other parameters are qualified for all process corners but not tested on every part.)

Parameter	Symbol	Test Conditions / Notes	Min	Typ	Max	Unit	Screened
-----------	--------	-------------------------	-----	-----	-----	------	----------

DIRECT DIGITAL OUTPUT (available only through custom mode)

Dynamic Range	DR		-80	-86		dB	●
Noise Floor				50	75	μV	●

LOW-SPEED A/D

Input voltage	V _{in}		0		2*VREG	V	
Sampling frequency		For each LSAD channel	1.6	MCLK/28	4.8	kHz	
Input impedance	R _{in}		1			MΩ	
Offset error		Input at VREG	-10		10	LSB	
Gain error		Input to VSSA or 2*VREG	-10		10	LSB	
INL	INL	VDDO > 2.15 V	-4		4	LSB	
DNL	DNL	VDDO > 2.15 V	-2		2	LSB	

DIGITAL PADS (VDDO = 1.8 V)

Voltage level for Low input	V _{IL}		-0.3		0.4	V	
Voltage level for High input	V _{IH}		1.30		1.98	V	
Pull-up resistance			63	114	162	kΩ	
Pull-down resistance			87	153	215	kΩ	
Rise and Fall Time		20 pF load	2	3	5	ns	

DIGITAL PADS (VDDO = 3.3 V)

Voltage level for Low input	V _{IL}		-0.3		0.8	V	●
Voltage level for High input	V _{IH}		1.8		3.6	V	●
Pull-up resistance			34	46	74	kΩ	●
Pull-down resistance			29	56	86	kΩ	●
Rise and Fall Time		20 pF load	1.0	1.5	2.0	ns	

DIGITAL PADS (Common parameters)

Drive Strength				12		mA	
ESD Immunity	HBM	Human Body Model	2.5			kV	
	MM	Machine Model	200			V	
Latch-up Immunity		25°C, V < GND0, V > VDDO	150			mA	

CLOCKING CIRCUITRY

External clock frequency	EXT_CLK	With preset 6 selected on CONFIG_SEL (Note 2)		19.2		MHz	
	EXT_CLK	With presets 4 or 7 selected on CONFIG_SEL (Note 2)		26		MHz	
Reference clock duty cycle			40	50	60	%	
External Input clock jitter		Maximum allowed jitter on EXT_CLK			10	ns	

I²C INTERFACE

Maximum speed					400	kbps	
---------------	--	--	--	--	-----	------	--

2. Many other clock frequencies are available through custom configuration of the internal PLL and clocking subsystem. See later in this document and in the BelaSigna R261 Configuration and Communications Guide for more information on custom mode usage.

BelaSigna R261

Table 3. PIN CONNECTIONS

Pin Index	Pin Name	Description	A/D/P	I/O	Active	Pull
G1	MIC0	First microphone input	A	I		
E5*	AI1/LOUT1	Direct audio input / line-out preamp 1	A	I/O		
E1	MIC2	Second microphone input	A	I		
E3	AI3/VMIC/LOUT0	Direct audio input / microphone bias / line-out preamp 0	A	I/O		
D6*	A_OUT0	Audio output 0	A	O		
E7	A_OUT1	Audio output 1	A	O		
G7	CAP0	Charge pump capacitor connection	P	IO		
F8	CAP1	Charge pump capacitor connection	P	IO		
A1	DEBUG_RX	RS232 debug port serial input	D	I	L	U
B2	DEBUG_TX	RS232 debug port serial output	D	O	L	
F2	RESERVED	Reserved				
A3	EXT_CLK	External clock input	D	I		U
A7	SPI_CLK/CONFIG_SEL	SPI clock / Configuration selection	D/A	O/I	L/-	
A9	SPI_CS/ATT_SEL	SPI chip select / Attenuation selection	D/A	O/I		
B8	SPI_SERO/ALGO_CTRL	SPI serial output / Algorithm control	D/D	O/I		-/U
C9	SPI_SERI/SLEEP_CTRL	SPI serial input / Sleep mode control	D/D	I/I		U/U
C7	DMIC_OUT	Digital microphone output	D	O		
C5*	BOOT_SEL	Boot selector	D	I		U
C3	I2C_SDA	I ² C data	D	IO	L	U
C1	I2C_SCL	I ² C clock	D	IO	L	U
D4*	NRESET	Reset	D	I	L	U
F6	VBAT	Power supply	P	I		
G9	VBATRCVR	Output driver power supply	P	I		
G5	VDDA	Analog supply voltage	P	O		
B6	VDDD	Digital power supply	P	O		
B4	VDDO	Digital I/O power supply	P	I		
G3	VREG	Analog supply voltage	P	O		
F4	VSSA	Analog ground	P	I		
A5	VSSD	Digital ground	P	I		
E9	VSSRCVR	Output driver ground	P	I		

* Pins C5, D4, D6 and E5 are not available on the WLCSP26 package.
All pins are available on the WLCSP30 package.

A: Analog pin
D: Digital pin
P: Power pin
I: Input
O: Output
IO: Bi-directional
I/O & O/I: Input or Output depending on the function being used
L: Active Low
H: Active High
U: Pulled up internally
D: Pulled down internally

BelaSigna R261

Application Diagrams

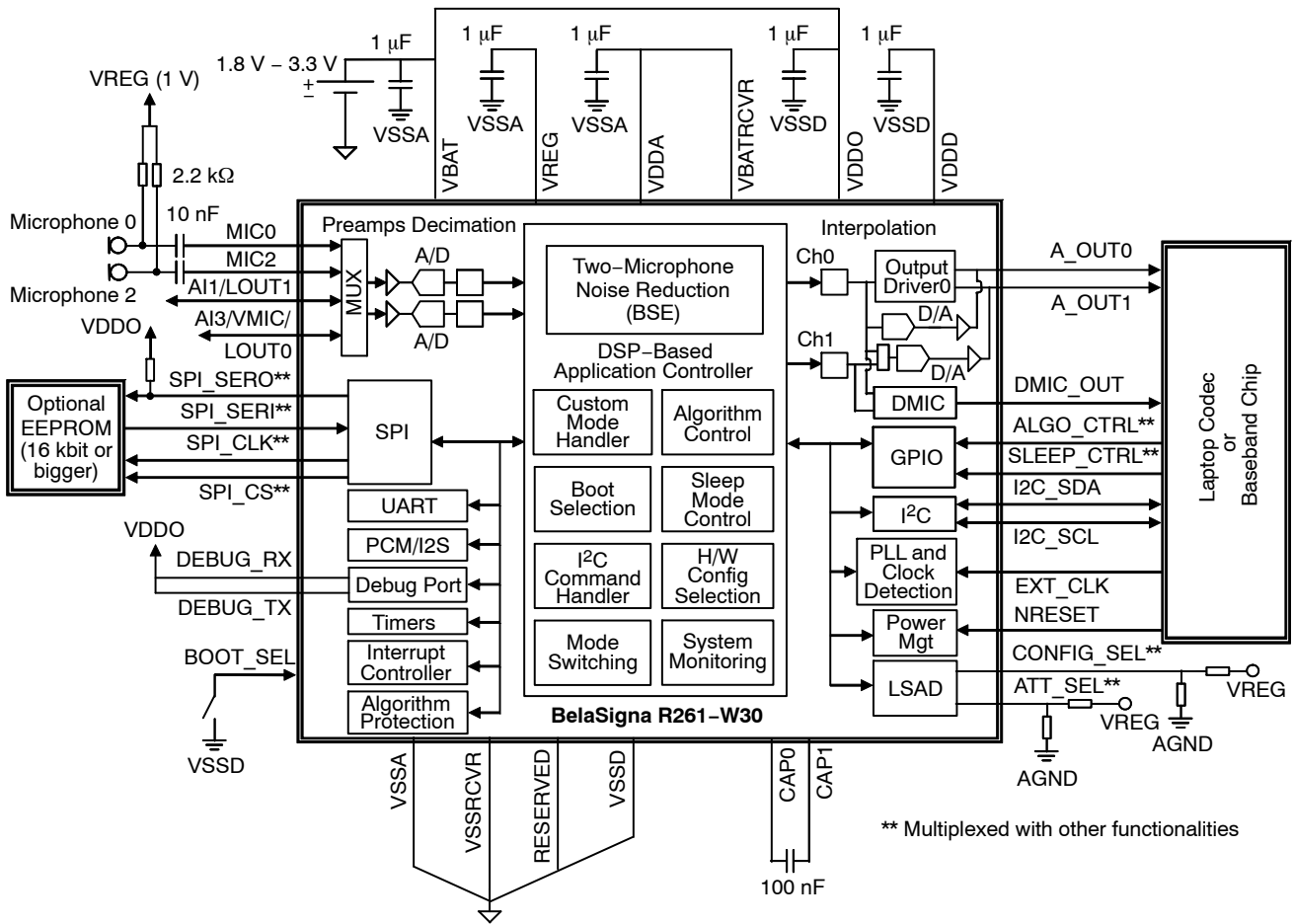

Figure 1. Typical Application Diagram for 30-ball WLCSP Package Option

BelaSigna R261

Application Diagrams

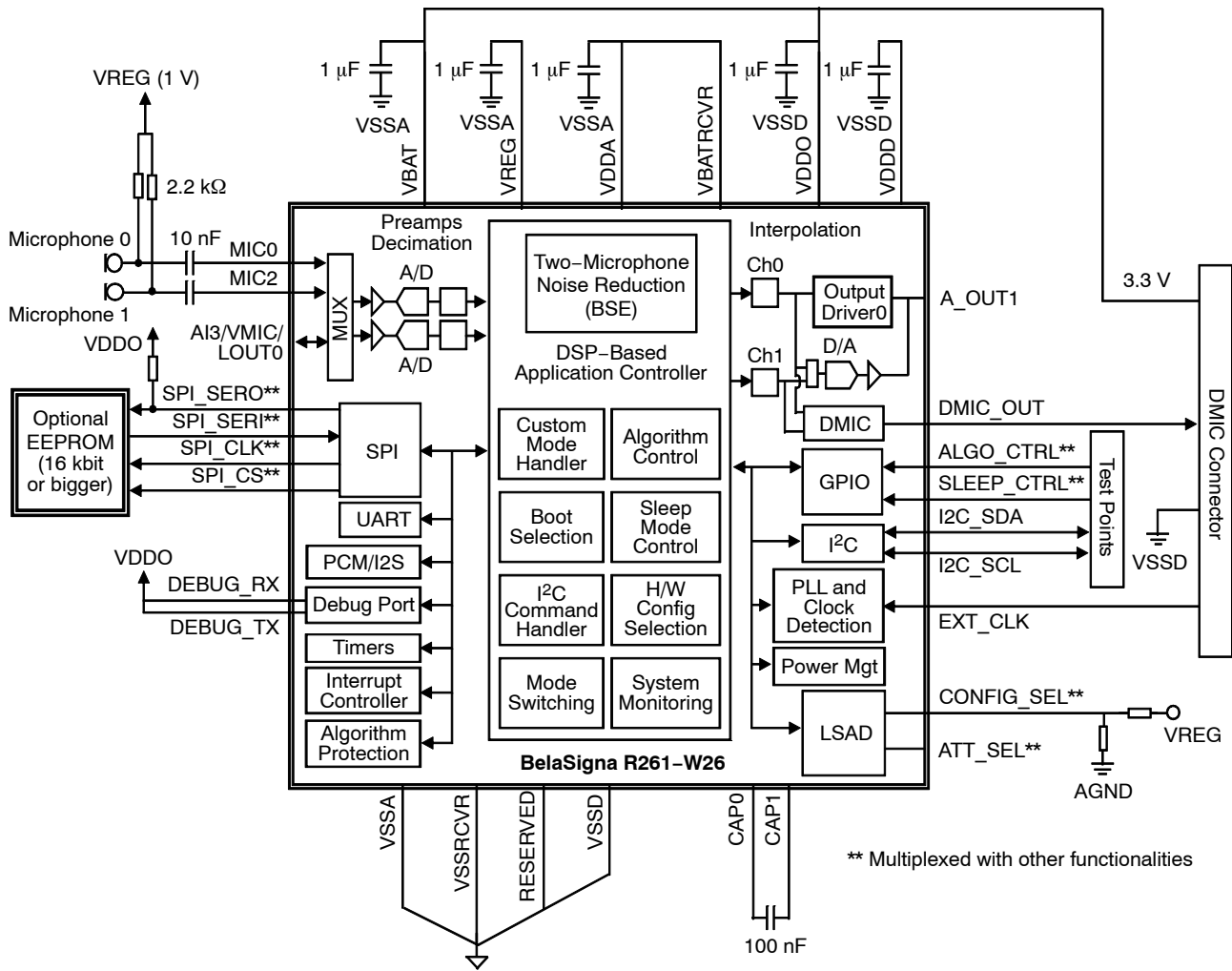

Figure 2. Typical Application Diagram for 26-ball WLCSP Package Option

BelaSigna R261

Applications Information

Recommended Circuit Design Guidelines

BelaSigna R261 is designed to allow both digital and analog processing in a single system. Due to the mixed-signal nature of this system, careful design of the printed circuit board (PCB) layout is critical to maintain the high audio fidelity of BelaSigna R261. To avoid coupling noise into the audio signal path, keep the digital traces away from the analog traces. To avoid electrical feedback coupling, isolate the input traces from the output traces.

Recommended Ground Design Strategy

The ground plane should be partitioned into two parts: the analog ground plane (VSSA) and the digital ground plane (VSSD). These two planes should be connected together at a single point, known as the star point. The star point should be located close to the negative terminal of the power source, as illustrated in Figure 3.

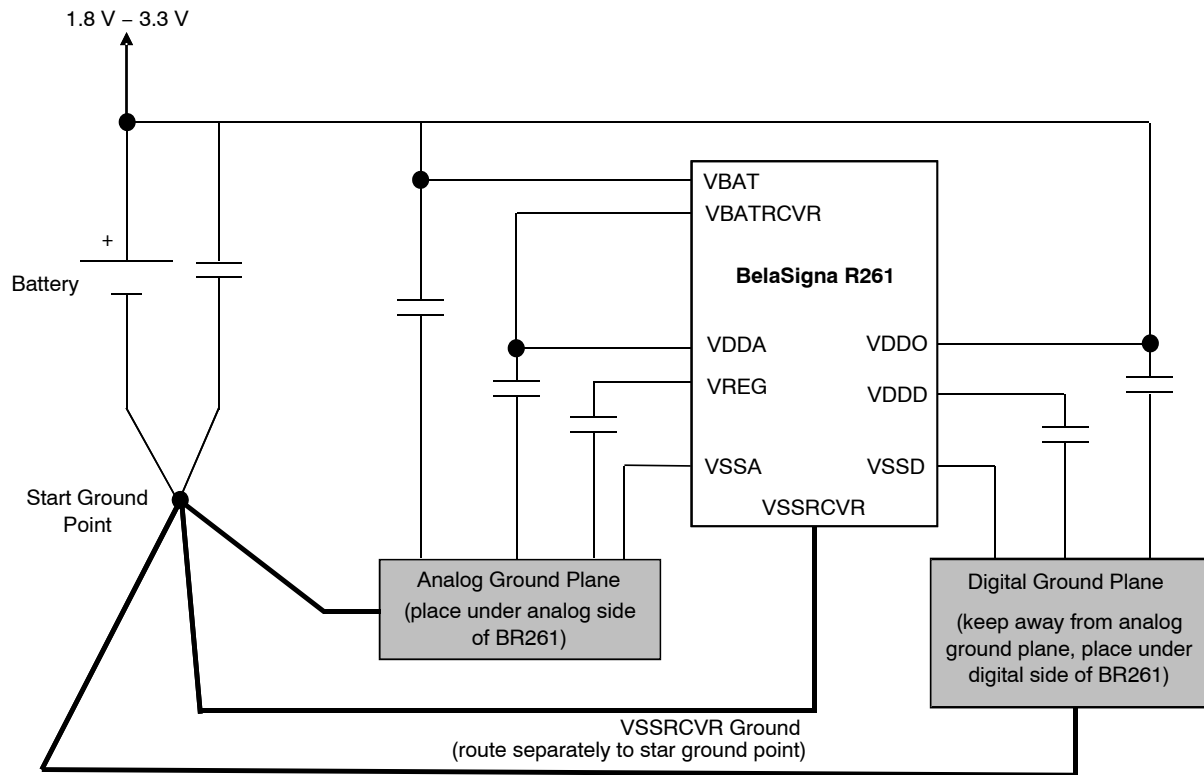

Figure 3. Schematic of Ground Scheme

BelaSigna R261

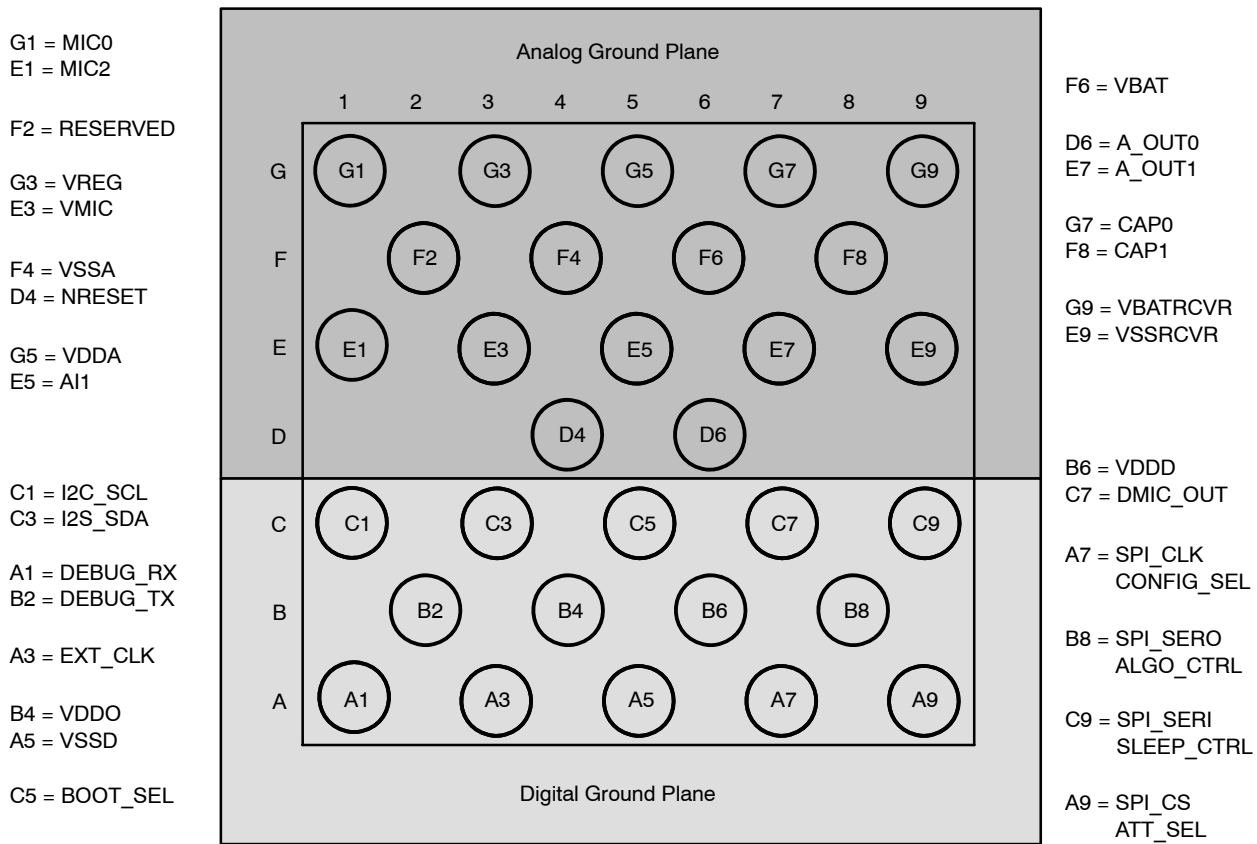

Figure 4. Proposed Ground Plane Positioning (soldering footprint view)

The VSSD plane is used as the ground return for digital circuits and should be placed under digital circuits. The VSSA plane should be kept as noise-free as possible. It is used as the ground return for analog circuits and it should surround analog components and pins. It should not be connected to or placed under any noisy circuits such as RF chips, switching supplies or digital pads of BelaSigna R261 itself. Analog ground returns associated with the audio output stage should connect back to the star point on separate individual traces.

For details on which signals require special design consideration, see Table 4 and Table 5.

In some designs, space constraints may make separate ground planes impractical. In this case a star configuration strategy should be used. Each analog ground return should connect to the star point with separate traces.

Internal Power Supplies

Power management circuitry in BelaSigna R261 generates separate digital (VDDD) and analog (VREG, VDDA) regulated supplies. Each supply requires an external decoupling capacitor, even if the supply is not used externally. Decoupling capacitors should be placed as close as possible to the power pads.

The digital I/O levels are defined by a separate power supply pin on BelaSigna R261 (VDDO). This pin must be externally connected by the application PCB, usually to VBAT. Note that the voltage on VDDO will influence the behavior of the LSADs. The system is designed with the assumption that a 3.3 V power supply voltage is provided on VBAT, and that VDDO connects to VBAT on the application PCB.

Further details on these critical signals are provided in Table 4. Non-critical signals are outlined in Table 5. More information on the power supply architecture can be found in the Power Supply Unit section.

BelaSigna R261

Table 4. CRITICAL SIGNALS

Pin Name	Description	Connection Guidelines
VBAT	Power supply	Place 1 μ F (min) decoupling capacitor close to pin Connect negative terminal of capacitor to analog ground plane
VREG, VDDA	Internal regulators for analog blocks	Place separate 1 μ F decoupling capacitors close to each pin Connect negative capacitor terminal to analog ground plane Keep away from digital traces and output traces VREG and VDDA may be used to generate microphone bias
VSSA	Analog ground return	Connect to analog ground plane
VDDD	Internal regulator for digital core	Place 1 μ F decoupling capacitor close to pin Connect negative terminal of capacitor to digital ground plane
VSSD	Digital ground return	Connect to digital ground plane
VDDO	Digital I/O power	Place 1 μ F decoupling capacitor close to pin Connect negative terminal of capacitor to digital ground plane Connect to VBAT, unless the pad ring must use different voltage levels
MIC0, MIC2, AI1/LOUT1, AI3/VMIC/LOUT0	Audio inputs / Microphone bias	Keep traces as short as possible Keep away from all digital traces and audio outputs Avoid routing in parallel with other traces Never connect AI3/VMIC/LOUT0 to ground
A_OUT0, A_OUT1	Audio outputs	Keep away from audio inputs Differential traces should be of approximately the same length Ideally, route lines parallel to each other
VSSRCVR	Output stage ground return	Connect to star ground point Keep away from all analog audio inputs
EXT_CLK	External clock input	Minimize trace length Keep away from analog signals If possible, surround with digital ground
DMIC_OUT	Digital Microphone Output	Minimize trace length Keep away from analog signals If possible, surround with digital ground

Table 5. NON-CRITICAL SIGNALS

Pin Name	Description	Connection Guidelines
CAP0, CAP1	Internal charge pump – capacitor connection	Place 100 nF capacitor very close to pins
I2C_SDA, I2C_SCL	I ² C port	Keep as short as possible. Place pull-up resistors (10 kΩ) to VDDO
ALGO_CTRL, SLEEP_CTRL	Control GPIOs (Multiplexed with SPI port)	Not critical when used as GPIO. Place 100 kΩ pull-up resistor to VDDO on ALGO_CTRL (SPI_SERO)
CONFIG_SEL, ATT_SEL	Low-speed A/D converters (Multiplexed with SPI port)	Not critical when used as LSAD
BOOT_SEL	Control GPIO	Not critical
SPI_CLK, SPI_CS, SPI_SERO, SPI_SERI	Serial peripheral interface port (Multiplexed with LSAD and GPIOs)	Keep away from analog input lines when used as SPI signals
NRESET	Reset	Not critical Leave unconnected if unused
DEBUG_RX, DEBUG_TX	Debug Port	Not critical If possible, connect to test points, otherwise connect both signals to VDDO
RESERVED	Reserved pin	Leave unconnected or connect to VSSA if PCB routing constraints force it
VBATRCVR	Output driver power supply	If the output driver is being used: <ul style="list-style-type: none"> – Place a separate 4.7 μF (min. 2.2 μF) decoupling capacitor close to pin – Connect positive terminal of capacitor to VBAT & VBATRCVR – Connect negative terminal of capacitor to VSSRCVR If the analog outputs or the DMIC output are being used: <ul style="list-style-type: none"> – Decoupling capacitor is not required – Connect VBATRCVR to VDDA

Audio Inputs

The audio input traces should be as short as possible. The input impedance of each audio input pad (e.g., MIC0, AI1, MIC2, AI3) is high (approximately 500 kΩ with preamplifiers enabled); therefore a 10 nF capacitor is sufficient to decouple the DC bias. This capacitor and the internal resistance form a first-order analog high pass filter whose cut-off frequency can be calculated by $f_{3dB} \text{ (Hz)} = 1/(R \times C \times 2\pi)$, which results in ~30 Hz for a 10 nF capacitor. This 10 nF capacitor value applies when the preamplifier is being used, in other words, when a non-unity gain is applied to the signals; for MIC0 and MIC2, the preamplifier is enabled by the ROM-based application. When the preamplifier is bypassed, the impedance is reduced; hence, the cut-off frequency of the resulting high-pass filter could be too high. In such a case, the use of a 30–40 nF serial capacitor is recommended. In cases where line-level analog inputs without DC bias are used, the capacitor may be omitted for transparent bass response. ON Semiconductor recommends the use of NPO/COG dielectric for SMT capacitors, as they have demonstrated better performance compared to other capacitors with X7R dielectric.

BelaSigna R261 provides a microphone power supply (VMIC) and ground (VSSA). In case VMIC cannot be used for PCB routing issues, the power supplies VREG (1.0 V) or VDDA (2.0 V) can alternatively be used. When selecting a power supply for microphones, it is important to note that

VREG has better load regulation compared to VDDA; ON Semiconductor recommends the use of VREG to bias microphones for optimal audio performance. Keep audio input traces strictly away from output traces.

Audio outputs must be kept away from microphone inputs to avoid cross-coupling.

Audio Outputs

The audio output traces should be as short as possible. The trace length of the two signals should be approximately the same to provide matched impedances.

Recommendation for Unused Pins

Table 6 shows the connection details for each pin when they are not used.

Table 6. UNUSED PIN RECOMMENDATIONS

Signal Name	Connection Guidelines
A_OUT0	Do not connect
A_OUT1	Do not connect
AI3/VMIC/LOUT0	Do not connect
AI1/LOUT1	Connect to VSSA
DMIC_OUT	Do not connect
SPI_SERO/ALGO_CTRL	Place 10 kΩ pull-up resistor to VDDO
SPI_SERI/SLEEP_CTRL	Do not connect
NRESET	Do not connect

BelaSigna R261

Architecture Detailed Information

The architecture of BelaSigna R261 is shown in Figure 5.

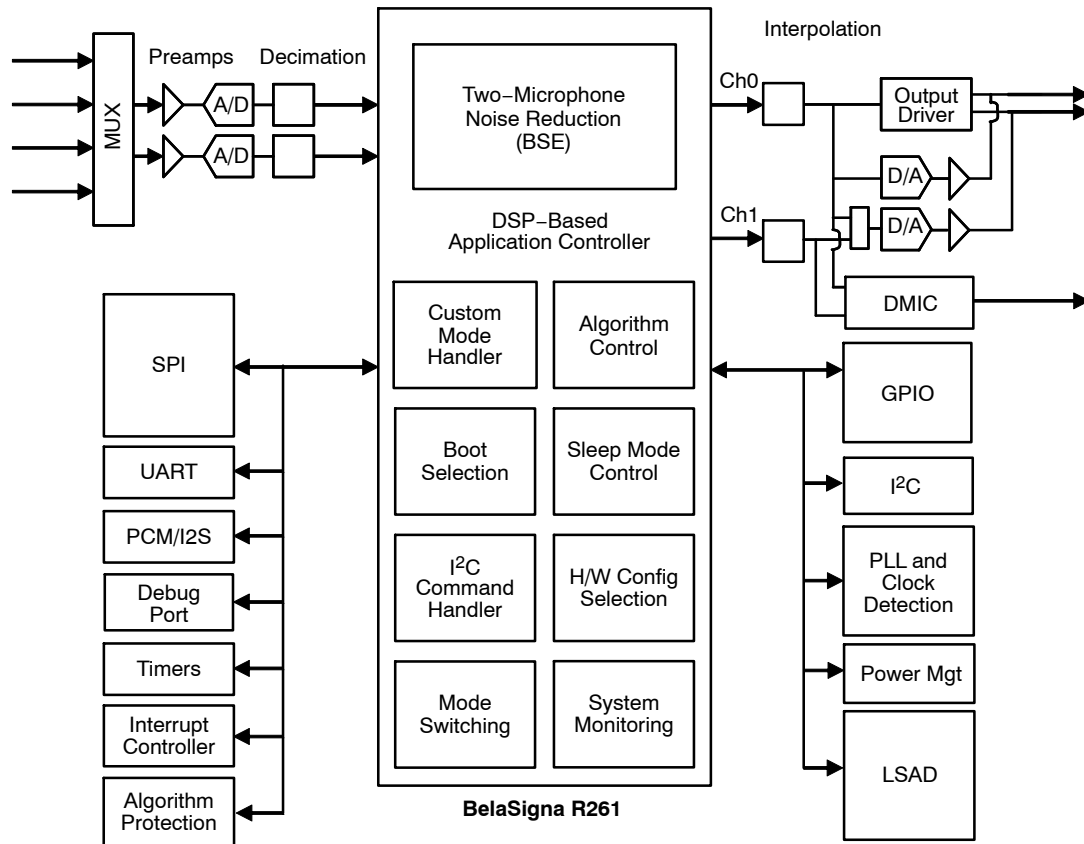

Figure 5. BelaSigna R261 Architecture: A Complete Audio Processing System

Two-Microphone Noise Reduction System

Blind Speech Extraction (BSE) from Exaudio AB

BelaSigna R261 contains the BSE algorithm from Exaudio inside its ROM memory. Exaudio offers a unique solution to the problem of blindly extracting wave propagating signals using one or more sensors without having any prior knowledge about source's or sensor's positions. The solution operates simultaneously in the frequency, temporal and spatial domains using one global optimization criterion, with no constraints on the number of sources vs. the number of sensors. The solution is Signal-to-Noise Ratio (SNR) independent, meaning that it operates optimally in both low SNR as in high SNR environments and at the same time it performs de-reverberation of the received signals. The solution is ideal for electronic communication devices such as mobile phones and portable computers where it is desired to extract useful speech signals hidden in various noise fields. The flexibility offered by Exaudio's solution allows for flexible microphone positioning and arbitrary placement of the self adaptive device in the actual environment.

Algorithm Modes

The noise reduction algorithm built into BelaSigna R261 has two algorithm modes called Algorithm Mode 0 and Algorithm Mode 1. Algorithm Mode 0 is optimized for far-talk applications where the end user can be very far from the microphones (up to 6 meters) such as laptops or speakerphones. This algorithm mode is also known as "Conference Mode". Algorithm Mode 1 is optimized for close-talk applications where the end user is close to the microphones (< 5 cm) such as telephony handsets (including cell phones in a handset mode).

A Custom Algorithm Mode is also available in BelaSigna R261; it provides support for special configurations and tuning by loading new algorithm parameters via an external EEPROM or the I²C control interface. The algorithm performance can be optimized for specific applications, microphone types and positioning as well as other system parameters via this mechanism. A typical example of custom algorithm tuning is "Near-Talk Mode", which offers impressive noise reduction with the end user located 30 to 50 centimeters from the microphone array.

This use case applies to applications like a single user in front of a notebook or a mobile phone used in speakerphone

BelaSigna R261

mode at arm's length from the user's mouth. In this case, a far-talk mode might not be appropriate, as it would not provide enough noise reduction, and a close-talk mode wouldn't be appropriate either, since the speaker would be too far away from the microphone array.

This illustrates the capability of BelaSigna R261 to deal with specific scenarios, either through its ROM based algorithm or through its flexible Custom Algorithm Mode. Contact your ON Semiconductor technical support for additional information about this "near-talk" mode, and other deployments of the custom algorithm mode.

For additional details on the custom mode handler and algorithm performance tuning options, please refer to "BelaSigna R261 Configuration & Communications Guide."

Algorithm Performance

BelaSigna R261 offers two built-in algorithm modes, Mode 0 is the far-talk mode and Mode 1 is the close-talk mode. These two modes behave differently and are intended for different applications. The close-talk mode aggressively filters noise and manages gain to pick up speech within 5 to 10 centimeters from the microphone array. The algorithm is not sensitive to handset holding style in any mode, including close-talk mode. Unlike other purely directional solutions, BelaSigna R261 will not drop your voice when you change the way you hold the device.

The far-talk mode detects and enhances speech from a distance, but removes less overall environmental noise

compared to close-talk mode. Far-talk mode is suitable for recording lectures or processing conference calls on speakerphone.

The algorithm automatically adjusts the noise reduction performance depending on the environment, and expects that, in very noisy environments, the user would naturally move closer to his communication device, whereas he may relax and increase the talking distance in quieter environments.

A custom near-talk mode (not built-in) is also available, which can effectively pick up speech within 0.5 m to 1 m from the microphone array, an intermediate situation between the built-in far-talk and close-talk modes. This is suitable for capturing speech when using the device at arm's length.

A selection of performance metrics are shown in Table 7 for some input signal-to-noise ratios and noise types. Signal-to-Noise Ratio Improvement (SNR-I) was measured according to the G.160 standard, with BelaSigna R261 operating on reference hardware, in conjunction with common omni-directional microphones (ECMs) positioned 11 mm away from each other. To verify that subjective quality was maintained through the noise management process, a Perceptual Enhancement of Speech Quality (PESQ) measurement was also taken for each condition. PESQ improvement (PESQ-I) correlates to MOS improvement, the widely accepted subjective standard in voice quality.

BelaSigna R261

Table 7. ALGORITHM PERFORMANCE

Parameter	Test Conditions	Value	Unit
CLOSE-TALK MODE (Built-in ROM)			
SNR Improvement (SNR-I)	White noise, 6 dB SNR	30.0	dB
	Babble noise, 9 dB SNR	20.6	dB
	Pink noise, 12 dB SNR	19.9	dB
PESQ Improvement (PESQ-I)	White noise, 6 dB SNR	0.8	-
	Babble noise, 9 dB SNR	0.3	-
	Pink noise, 12 dB SNR	0.4	-
FAR-TALK MODE (Built-in ROM)			
SNR Improvement (SNR-I)	White noise, 6 dB SNR	14.7	dB
	Babble noise, 9 dB SNR	6.9	dB
	Pink noise, 12 dB SNR	11.1	dB
PESQ Improvement (PESQ-I)	White noise, 6 dB SNR	0.7	-
	Babble noise, 9 dB SNR	0.4	-
	Pink noise, 12 dB SNR	0.5	-
NEAR-TALK MODE (Custom)			
SNR Improvement (SNR-I)	White noise, 6 dB SNR	19.6	dB
	Babble noise, 9 dB SNR	10.6	dB
	Pink noise, 12 dB SNR	14.5	dB
PESQ Improvement (PESQ-I)	White noise, 6 dB SNR	0.5	-
	Babble noise, 9 dB SNR	0.4	-
	Pink noise, 12 dB SNR	0.4	-

Optimal Talking Distance

BelaSigna R261 is a fully adaptive system that will automatically adjust its signal processing algorithm depending on the input conditions. As discussed earlier, the three modes discussed in this document, close-talk, near-talk and far-talk, all have distinct use cases. In addition to this, each of these modes will adjust the distance from the microphone that they effectively capture speech based on the amount of noise present. As an example, the close-talk algorithm will allow a pick-up distance up to 15 cm in very quiet situations, whereas it will shrink the pick-up distance when the noise around the microphone increases. This close-talk mode was designed to handle high noise situations up to 90 dB SPL. BelaSigna R261 automatically increases the level of noise reduction with the level of the noise: more noise means more noise reduction in the output.

The near-talk algorithm is tuned to pick up speech within 75 cm to 100 cm in a quiet environment, and will shrink the pick-up distance down to 20–30 cm if the noise level

increases. Given the extended pick-up distance, compared to the close-talk algorithm voice is effectively captured in noise situations up to 70 dB SPL with extremely good noise reduction.

The far-talk algorithm is designed to handle even lower noise levels (up to 50 dB SPL) with a much larger pick-up distance.

The following three graphs show the optimal talking distance for the three algorithm modes as a function of the input signal-to-noise ratio. When designing BelaSigna R261 into a voice pick-up device, it is important to assess the targeted use case of the product, and to consequently select an algorithm mode. It is also important to realize that the three modes discussed here are just examples of what can be obtained with BelaSigna R261. The custom algorithm mode allows a variety of changes to the algorithm behavior; adjustment of the talking distance and the noise reduction aggressiveness are just two of the performance parameters that can be controlled.

BelaSigna R261

TYPICAL CHARACTERISTICS

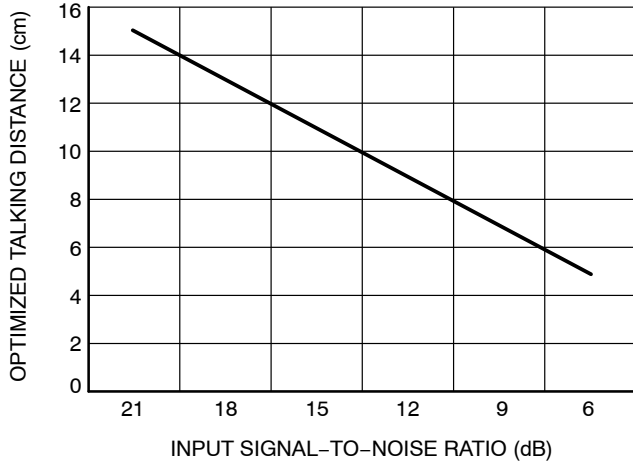

Figure 6. Close-Talk

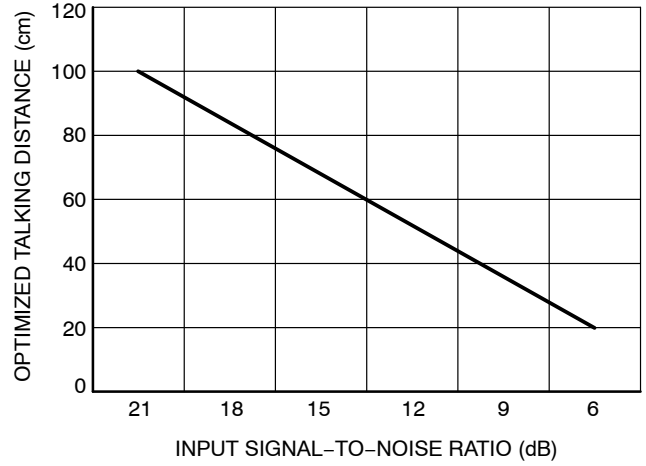

Figure 7. Near-Talk

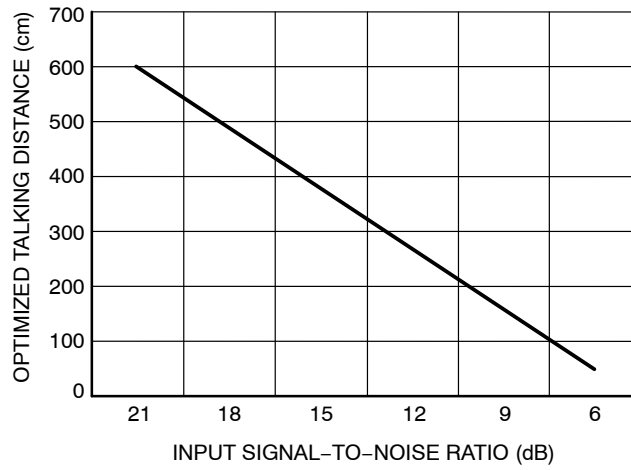

Figure 8. Far-Talk

BelaSigna R261

Microphone Placement & Selection

The flexibility of the BelaSigna R261 ROM-based noise reduction algorithm offers a variety of possible microphone placements, but the default algorithm will operate optimally when the microphones are placed in the following configuration:

- The two microphones are facing the user's mouth
- The microphone centers are located within 10 to 25 mm from each other

As mentioned, other configurations that differ from the above guidelines can be supported through the use of the custom mode, as described earlier.

BelaSigna R261 does not require any acoustic microphone calibration procedure.

The selection of the microphones should be made in cooperation with ON Semiconductor, such as the built-in algorithm can operate seamlessly. The following guidelines can be used for a pre-selection:

- Two omni-directional microphones with similar characteristics should be used
- The microphone sensitivity should be -42 dB (where 0 dB = 1 V/Pa, at 1 kHz)

- The microphones are two-terminal microphones
- The microphone power supply is either 1 V (recommended), or 2 V if it has to be provided by BelaSigna R261
- The dynamic range of BelaSigna R261 on its analog input channels is 2.0 V peak-to-peak, after amplification by the default gain value of 30 dB using BelaSigna R261's input preamplifiers
- When higher sensitivity microphones have to be used, the preamp gain will be adjustable to match the 2.0 Vpp input voltage swing on BelaSigna R261, but this will require a custom tuning operation, as described later.
- When MEMS microphone are to be used, a general increase of the algorithm performance can be expected due to the improved self noise of those microphones, compared to conventional electret microphones.

Operating Modes

The default application stored in the ROM of BelaSigna R261 has five Operating Modes. The Operating Modes are summarized in Table 8.

Table 8. OPERATING MODES SUMMARY

Operating Mode	Switching	Description
Active	Active mode is the default operating mode. The chip normally enters Active mode upon boot-up and when exiting Sleep mode. Active mode can also be entered via I ² C from another mode.	In Active mode, the two-microphone noise reduction algorithm is executed on the audio inputs and both the processed and unprocessed signals are sent to the audio outputs.
Bypass	Bypass mode can only be entered via an I ² C command.	In Bypass mode, no signal processing is done on the audio inputs. The inputs are passed directly to the audio outputs. While in Bypass mode, BelaSigna R261 collects statistics on the input signals that can be retrieved via I ² C. These signal statistics can be used for level calibration and other debugging. For more information using Bypass mode for calibration and debugging see the "BelaSigna R261 Configuration and Communications Guide"
Line-Out	Line-Out mode can only be entered via an I ² C command.	In Line-Out mode, no signal processing or digital processing of the audio inputs is done. The analog signals from the input stage preamplifiers are routed back via the lineout pins (LOUT0 and LOUT1). When in this mode, BelaSigna R261 runs off an internal clock source, thereby allowing the external clock to be disabled. Note that LOUT1 is not available on the 26-ball WLCSP package.
Sleep	Sleep mode can be entered via I ² C commands or by using the SLEEP_CTRL pin. When Sleep mode is entered via I ² C, the chip will exit Sleep mode only based on activity on the I ² C_SCL pin. When put to Sleep mode via the SLEEP_CTRL pin, the chip will exit Sleep mode only when the SLEEP_CTRL pin is toggled again. Sleep mode will be automatically entered if BelaSigna R261 detects that a required external clock is no longer present. For more information, see the Sleep Control section below.	In Sleep mode no signal processing is done. All analog blocks of the chip are disabled and the digital core continues to run off an internal low-speed oscillator, thereby allowing the external clock to be disabled when the chip is asleep. This is BelaSigna R261's lowest power operating mode.
Stand-By	Stand-By mode is an intermediate mode that is only used when exiting sleep mode by an I ² C command.	When I ² C is used to exit Sleep mode, the application will transition to Stand-By mode, and will wait until the master I ² C device issues a <i>Switch Mode</i> command to enter another processing mode like Active, Bypass or Line-Out. If no such command is issued, BelaSigna R261 will return to Sleep mode and wait for a valid wake-up sequence.

BelaSigna R261

Digital Control, Hardware Configuration and Interfaces

Boot Control

At power-on-reset, BelaSigna R261 will normally execute the application stored in ROM with the default hardware and algorithm configuration. Additional built-in hardware and algorithm configuration options are available as described later in this section by using the CONFIG_SEL and ATT_SEL pins. These settings are selected at boot-time based on the pin voltage levels.

The BOOT_SEL pin controls the booting method of BelaSigna R261. There are in fact two alternate methods to boot a custom application or hardware/algorithm configuration. These methods, along with the default boot method, are described in Table 9. Note that the BOOT_SEL pin is not available on the WLCSP-26 package option, consequently, this signal is left floating and the automatic boot selection described below applies for all applications using this reduced ball package variant.

Table 9. BOOT CONTROL OPTIONS

Boot Method	Condition	Description
EEPROM Boot (Automatic boot selection)	BOOT_SEL high (or floating/not available on package)	Enables SPI interface and attempts to boot from external EEPROM. EEPROM may contain a custom application or configuration. If no EEPROM, or bad content, loads the default application in ROM with hardware and algorithm configuration determined by CONFIG_SEL and ATT_SEL pins.
LSAD Boot	BOOT_SEL low	Loads default application in ROM. Hardware and algorithm configuration determined by CONFIG_SEL and ATT_SEL pins.
I ² C Boot	Connect to BelaSigna R261 via I ² C after default boot-up	The I ² C control interface can be used to download a custom application, or to re-configure the default application. See the "BelaSigna R261 Configuration and Communications Guide" for more information.

When the automatic boot selection process is being used, either when selecting the 26-ball package version, or simply when leaving the BOOT_SEL pin unconnected on the application PCB, it is very important to ensure that the SPI pins will not be driven by any external hardware component. Typically, a custom application may want to use the PCM interface, which is also multiplexed with the SPI port. Extreme care must be taken in such use cases, to ensure that the SPI ports remain at high impedance during the boot process. Contact your local technical support for more information on this particular use case.

When a host I2C processor will download a custom application to BelaSigna R261, it is still mandatory to ensure that the CONFIG_SEL is properly configured, such as the device will properly boot, and get ready for I2C communication. Without proper clock settings defined on this pin, it may happen that BelaSigna R261 never succeeds to boot, and consequently, will prevent I2C communication to happen.

Reset

BelaSigna R261 can be forced to execute a power-on-reset by pulling the NRESET pin to ground for

at least 100 ns. Note: NRESET is not available on the 26-ball WLCSP package.

Algorithm Control

BelaSigna R261 has provisions to control whether the noise reduction algorithm processed signal is output, or an unprocessed signal is output. This effectively enables or disables the algorithm. The algorithm can be controlled via the I²C interface or by use of the ALGO_CTRL pin. When using the ALGO_CTRL pin, the algorithm state is toggled whenever the digital signal transitions to low and stays low for at least 10 ms, as shown in Figure 9. The actual transition between algorithm enable/disable states can occur at any time during the 10 ms low period of the signal. As designed in ROM, the algorithm control mechanism in BelaSigna R261 expects a digital signal, driven high or low by a host controller. It has not been designed for control of this signal by a mechanical button or switch. As a consequence, no button de-bouncing is applied when using the ROM functionality. Custom applications with proper button de-bouncing can be obtained from ON Semiconductor. Contact your local technical support for additional information.

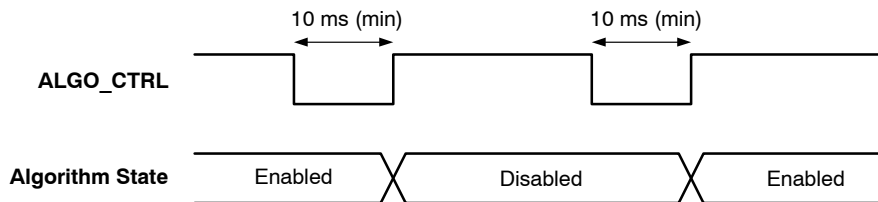

Figure 9. ALGO_CTRL Timing Diagram

BelaSigna R261

BelaSigna R261 has two processing channels (Channel 0 and Channel 1), when the noise reduction algorithm is enabled, Channel 0 contains the processed signal and Channel 1 contains the unprocessed signal. The effect of toggling the algorithm state is to swap Channel 0 and Channel 1, i.e. disabling the algorithm causes Channel 0 to contain the unprocessed signal and Channel 1 to contain the processed signal. These two output channels represent the internal DSP output signals with BelaSigna R261. The DMIC and analog audio outputs can each be configured to use either channel. See the Output stage section to see how Channel 0 and Channel 1 are used by the various configuration options of BelaSigna R261's output stage.

Sleep Control

As described in Table 8, there are multiple methods to enter and exit from Sleep mode. Each of these methods is

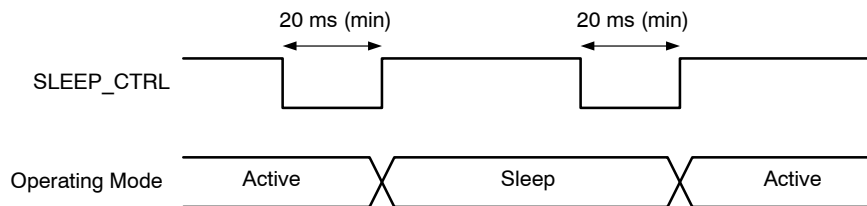

Figure 10. SLEEP_CTRL Timing Example

The second method for Sleep mode control is via the I²C interface. The *Switch_Mode* command can be used directly to switch the system into and out of Sleep mode. If the *Switch_Mode* command is used to put the chip into Sleep mode, only another *Switch_Mode* command or a reset will take the system out of Sleep mode. When waking up by I²C commands, the following I²C operations have to be performed by the master I²C to ensure proper wake-up:

1. Send a *NOP* command to wake up the I²C interface. This command will not be interpreted by BelaSigna R261, so the master will have to deal with any I²C errors that result.
2. Send the *Get_Status* command in a while-type loop, until a response from BelaSigna R261 is sent, and that confirms that the application is in Standby Mode.
3. Send a *Switch_Mode* command to enter the desired mode (Active, Bypass or Line-Out).

When the *NOP* command is sent and the chip wakes up, the master has about one second to complete the above procedure before the chip goes back to Sleep mode. This mechanism was put in place to deal with I²C bus traffic that would wake the chip up unintentionally (i.e. communications between the master and another slave on the I²C bus).

The final mechanisms for entering Sleep mode are considered fail safes to maintain a graceful system shutdown in the case of invalid operating conditions (i.e. the clock source suddenly stopped). In these circumstances, the chip

will enter sleep mode to ensure proper shutdown. More information on this can be found in the system monitoring section.

The first Sleep mode control mechanism is the SLEEP_CTRL pin. When using SLEEP_CTRL, the application will transition into or out of Sleep mode whenever the digital signal transitions to low and stays low for at least 20 ms, as shown in Figure 10. The actual transition between modes can occur at any time during the 20 ms low period of the signal. When SLEEP_CTRL is used to put the chip into Sleep mode, only another high-to-low transition on SLEEP_CTRL or a reset will take the system out of Sleep mode.

The operating mode after exiting Sleep mode using the SLEEP_CTRL mechanism is always Active mode.

will enter sleep mode to ensure proper shutdown. More information on this can be found in the system monitoring section.

The SLEEP_CTRL pin must be used with extreme care when the automatic boot selection method is being used (as described in Table 9), as BelaSigna R261 will start by searching for an SPI EEPROM on the multiplexed pins. Consequently, the SLEEP_CTRL pin must stay unconnected or at high impedance in this mode, while BelaSigna R261 is trying to communicate with the SPI EEPROM. Failure to do so may prevent BelaSigna R261 to boot from the serial EEPROM. Other mechanisms for controlling sleep mode can be used in such cases. This limitation is always there with the 26-ball WLCSP package of BelaSigna R261, since the BOOT_SEL pin is not available.

Clocking, Output Stage & Algorithm Configuration

As mentioned in the Boot Control section, BelaSigna R261 can be controlled by hardware configuration when no EEPROM is present in the application, when an empty EEPROM or one with invalid content is connected, or when the BOOT_SEL signal is tied low. The CONFIG_SEL signal is sampled by BelaSigna R261 during its booting process using a low-speed A/D converter (LSAD). Based on the actual voltage that the chip will read on this pin, it will automatically select a particular clock, output stage and algorithm configuration, as described in Table 10:

BelaSigna R261

Table 10. CLOCKING, OUTPUT STAGE AND ALGORITHM CONFIGURATION OPTIONS

Clock, Output Stage & Algorithm Configuration		Voltage Range (V)							
		0 (High)	1	2	3	4	5	6	7 (Low)
		0.93–1.00	0.79–0.91	0.65–0.77	0.50–0.63	0.36–0.49	0.22–0.35	0.08–0.21	0 – 0.07
External Clock Frequency (MHz)	2.048	X					X		
	2.4		X						
	3.072			X					
	2.8				X				
	19.2							X	
	26					X			X
Output Stage Configuration	DMIC Stereo	X	X	X	X		X		
	Analog Mono	X	X	X	X	X	X	X	X
Algorithm Mode		Mode0	Mode0	Mode0	Mode0	Mode0	Mode1	Mode1	Mode1
		Far-Talk					Close-Talk		

BelaSigna R261

The use of a resistive divider as shown in Figure 11 allows the application to select the appropriate combination of clock, output stage and algorithm mode. The LSAD is using a voltage range between 0 and 1 V. The actual voltage levels

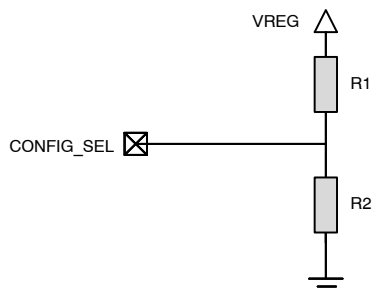

that need to be guaranteed by the application circuitry are also mentioned in Figure 11. The figure proposes actual resistor values to reach the eight different presets.

Preset	R1	R2	Voltage Range
0	10 kΩ	–	0.93 – 1.00 V
1	16 kΩ	100 kΩ	0.79 – 0.91 V
2	39 kΩ	100 kΩ	0.65 – 0.77 V
3	75 kΩ	100 kΩ	0.50 – 0.63 V
4	100 kΩ	75 kΩ	0.36 – 0.49 V
5	100 kΩ	39 kΩ	0.22 – 0.35 V
6	100 kΩ	16 kΩ	0.08 – 0.21 V
7	–	10 kΩ	0 – 0.07 V

Figure 11. Resistive Dividers for LSAD Preset Selection

It is important to note that the configuration is only read by the chip at boot time, and consequently, it will not be dynamically updated. So if the voltage on the CONFIG_SEL is changing during operation, it will only have an impact at the next reboot operation.

Analog Output Attenuation Control

The hardware configuration method described above, using an LSAD and a resistive divider is also being used on another signal called ATT_SEL, such that the application

can select an analog output attenuation to be applied on the analog output signals. Typically, when interfacing BelaSigna R261 with a baseband chipset in a cell phone application, it is very often required to match the amplitude of the output signals to the input range requirements of the baseband processor. Table 11 describes the available values, and their corresponding preset. The resistive dividers described in Figure 11 can also be used to configure the ATT_SEL pin.

Table 11. OUTPUT ATTENUATION CONTROL OPTIONS

ATT_SEL: Analog Output Attenuation Select	Voltage Range							
	0 (High)	1	2	3	4	5	6	7 (Low)
	0.93–1.00	0.79–0.91	0.65–0.77	0.50–0.63	0.36–0.49	0.22–0.35	0.08–0.21	0 – 0.07
Output Attenuation (Ch0 & Ch1)	0 dB	12 dB	15 dB	18 dB	21 dB	24 dB	27 dB	30 dB

I²C Command Handler

The BelaSigna R261 ROM application contains an I²C-based command and control interface, allowing many aspects of the chip’s operation and hardware configuration to be controlled via I²C. This I²C interface is the recommended way to control the chip and to configure the application at run-time. The default I²C address of BelaSigna R261 is 0x61. The I²C interface protocol is fully supported by the SignaKlara Device Utility (SKDU).

For more information on the I²C interface, please refer to the I²C interface section of this document, and to the “BelaSigna R261 Configuration and Communications Guide.”

System Monitoring

The application software within BelaSigna R261 is equipped with a few blocks that monitor system sanity. A watchdog timer is used to ensure proper execution of the signal processing application. It is always active and is periodically acknowledged as a check that the application is

still running. Once the watchdog times out, a hardware system reset will occur. System sanity is also monitored by the clock detection mechanism; the chip will automatically enter Sleep mode if it is in Active or Bypass mode and it detects that the external clock source (the signal on EXT_CLK) is stopped. In this case, the system will only exit Sleep mode when it detects that the external clock source has been restored or a reset occurs.

The power supply blocks of the system also monitor for minimum supply voltages as part of the power supervision strategy, as described in the Power Management section.

Analog Blocks

Input Stage

The BelaSigna R261 analog audio input stage is shown in Figure 12. The input stage is comprised of two individual channels. There are four configurable aspects of each channel – input multiplexing, preamplifier gain, filtering and lineout. The input multiplexing allows one input to be

BelaSigna R261

selected from any of the four possible inputs and then routed to the inputs of the preamplifier. Each preamplifier can be configured for bypass or gain values of 12 to 30 dB in 3 dB steps. The filters can be configured as well; the DC removal high-pass filter can be bypassed, or set to a cut-off frequency of 5 Hz, 10 Hz or 20 Hz (default). The low-pass filter can be either enabled with a 20 kHz cut-off frequency (default), or bypassed. The lineout selection allows the preamplifier outputs to be routed back out via the auxiliary audio input pins. Note that the AI1/LOUT1 pin is not available on the WLCSP-26 package option.

Two oversampled 16-bit sigma-delta analog-to-digital converters then convert the analog signals into the digital domain. The ADCs are running at a sampling rate of 16 kHz in both Bypass and Active mode. The sampling rate can potentially be changed using the I²C interface. Changing the sampling rate in Active mode will cause the noise cancellation algorithm to stop operating properly, so this

should not be done; however, the sampling rate in Bypass mode could potentially be changed to other values. Contact your local technical support for more information.

Input signal amplitudes can also be adjusted in the digital domain; digital gain for both converted signals can be adjusted by using I²C commands.

The ROM-based application pre-configures all these parameters in the input stage such that the algorithm operates properly. These parameters can be changed using the I²C interface, but extreme care should be taken when doing so as this could alter the performance of the algorithm.

The AI3 pin is multiplexed with the microphone power supply. The default mode for the microphone bias is to be used as a 2 V power supply. Consequently, any application that plans to use the AI3 input pin or the LOUT0 functionality has to change the VMIC setting to high-impedance mode, such as the pin can be properly used as an analog input or a line-out.

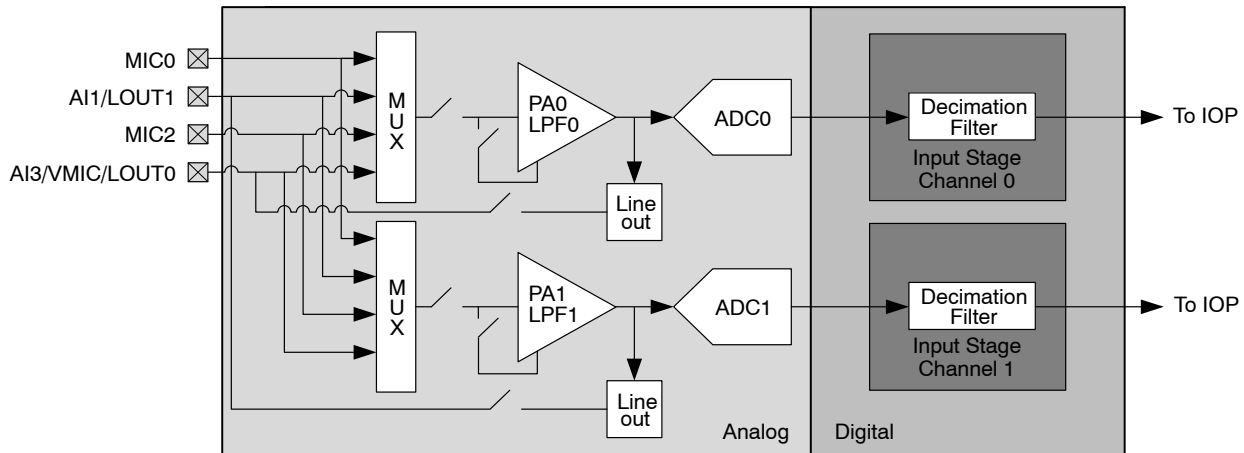

Figure 12. Input Stage

Output Stage

At all times, the application will produce two output channels. The content of each channel is determined by the state of the algorithm enable/disable bit, as explained in the Algorithm Control section. When the algorithm is enabled, Channel 0 will contain the processed signal and Channel 1 will contain the un-processed signal. Toggling the algorithm bit will swap these two channels. These two output channels will then be transmitted to the output stage hardware block.

Independently from the actual output stage that was selected, the amplitude of both the processed and the non-processed channels can be controlled by I²C commands. A first parameter determines the number of output shifts (6 dB attenuation or amplification, depending on the sign) that will be applied to the channels. A second parameter is a finer mechanism that allows applying a fractional, broadband gain on the channels. With these two mechanisms, applied in the digital domain by the application processor, a great level of flexibility is provided to match the

output level requirements of the target application independently for the two output channels. The ROM-based application has initialized these parameters for proper operation of the algorithm and correct output levels, so extreme care should be taken when modifying these parameters.

The BelaSigna R261 output stage is shown in Figure 13. The output stage processes the two channels although, depending on the configuration, one or both of the output signals are available on the output pins. There are four options for audio outputs from BelaSigna R261 – a digital microphone (DMIC) interface, a low-impedance output driver, a stereo single-ended analog output or a mono differential analog output. All outputs are generated from a sigma-delta modulator which produces a pulse density modulated (PDM) output signal and then provides it to the appropriate output system, based on the system configuration.

BelaSigna R261

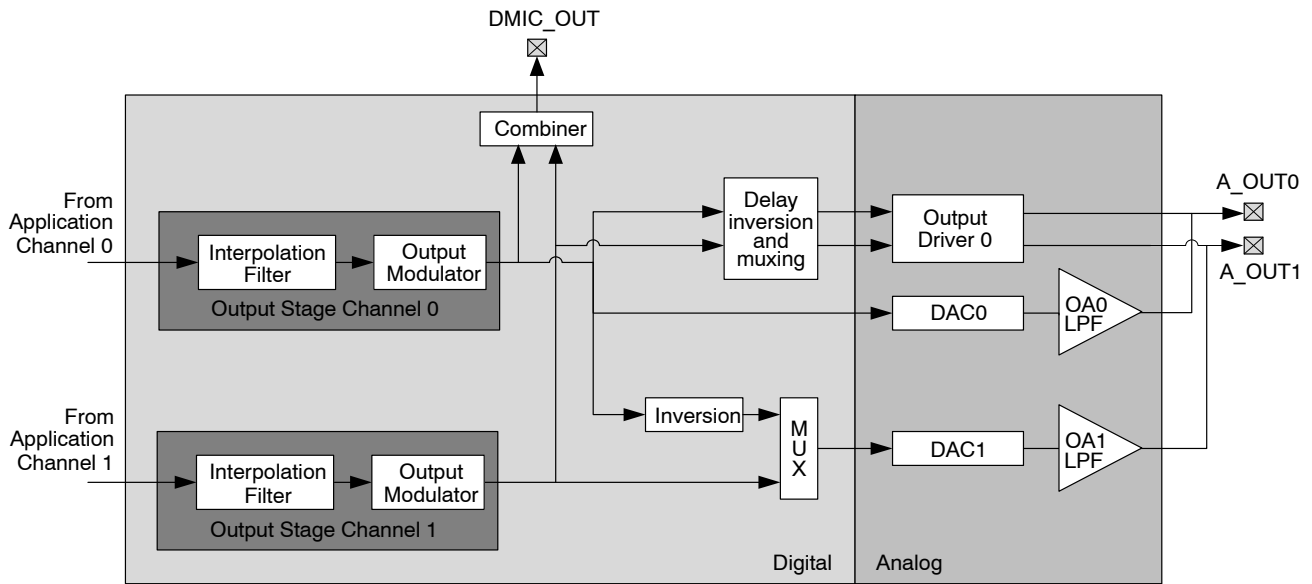

Figure 13. Output Stage

The digital microphone interface provides the PDM signals directly on a pin (DMIC_OUT), for interfacing with the DMIC input of external systems. When using this interface, the EXT_CLK input to BelaSigna R261 must be given a DMIC_CLK signal and the system’s clocking must be set up such that proper synchronization can happen between the incoming DMIC_CLK and the output data produced by BelaSigna R261 on its DMIC_OUT pin. Various DMIC_CLK frequencies are supported through hardware configuration on the CONFIG_SEL pin, as discussed earlier. Other frequencies could also be supported

under certain conditions; see the clocking section of this document for more information on the supported DMIC clock frequencies.

The DMIC output can be configured to carry a mono or stereo signal. In fact both left and right signals can be configured to either contain output stage channel 0 or output stage channel 1. Also, both left and right can be configured to be muted independently (driving a ‘0’ all the time).

Figure 14 shows the timing of the DMIC output data relative to the incoming DMIC_CLK signal. See Table 2 for electrical specifications of the timing parameters.

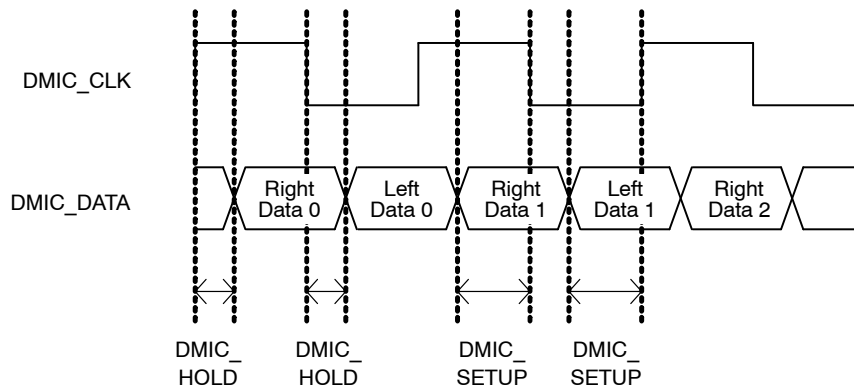

Figure 14. DMIC Timing Diagram

The ROM-based application pre-configures the DMIC interface, such as it always outputs a stereo signal with Channel 0 as the right signal, and Channel 1 as the left signal. Table 12 shows the actual signals on the right and left channels of the DMIC interface, depending on the algorithm enable/disable bit.

Table 12. DMIC OUTPUT SIGNALS

	Algorithm Enabled	Algorithm Disabled
Right	BSE processed signal	Un-processed signal
Left	Un-processed signal	BSE Processed signal

The DMIC host can consequently ignore the algorithm enable/disable functionality, as both processed and un-processed signals are always output for all pre-defined DMIC configurations. This functionality can still be used with custom DMIC configurations, such as mono. These custom configurations can be made over the I²C interface.

When the DMIC interface is not required or needed, the analog outputs can be used for interfacing at line-levels or other signal levels, e.g. microphone levels for an external system such as an analog baseband chipset which expects low level signals.

There are two configurable aspects of the analog output stage – the selection of stereo (two single ended outputs) or mono (one differential output) and the output attenuation. When a stereo single-ended option is selected, each channel is filtered to generate an analog signal which is then scaled by a configurable output attenuator (OA in Figure 13). In mono differential mode, channel 1 is replaced by an inverted version of channel 0 such that the two output pins contain a differential signal for channel 0. In this latter case, both output attenuators are used, so it is mandatory to ensure that they have the same attenuation settings. This can be configured using I²C commands.

As defined with the CONFIG_SEL pin, some pre-defined configurations have been designed specifically for use with analog output instead of DMIC interface. For these configurations, a differential mono analog output is pre-configured by the ROM-based application. Consequently, the host processor will have to use the algorithm enable/disable pin (ALGO_CTRL) or the I²C interface, to swap between the processed and the non-processed signal, as shown in Table 13:

Table 13.
ANALOG MONO DIFFERENTIAL OUTPUT SIGNAL

	Algorithm Enabled	Algorithm Disabled
A_OUT0 - A_OUT1	BSE processed signal	Un-processed signal

Alternatively, when stereo analog outputs have been configured through the I²C interface, the signals on the two output pins will be as shown in Table 14:

Table 14. ANALOG STEREO OUTPUT SIGNALS

	Algorithm Enabled	Algorithm Disabled
A_OUT0	BSE processed signal	Un-processed signal
A_OUT1	Un-processed signal	BSE Processed signal

The attenuation of these analog signals can be done by using the ATT_SEL mechanism described earlier, but alternatively, the I²C interface can also be used for this purpose.

The WLCSP-26 package option doesn't provide access to the A_OUT0 pin. Consequently, only A_OUT1 is available as an analog output. For the predefined configurations (using CONFIG_SEL), the analog output stage is configured to provide a mono differential output signal, as described in Table 13. The A_OUT1 signal will thus be an inverted version of the processed output channel. Access to the un-processed signal will have to be done with an I²C command, or potentially with the ALGO_CTRL signal, with the precautions discussed earlier concerning the automatic booting process (See the Boot Control section for additional details).

A third output method is available on BelaSigna R261; using the Class-D output driver which can drive an output transducer without the need for a separate power amplifier. The output driver can also be configured for single ended stereo or differential mono through the same I²C commands as described for the analog outputs.

For optimal audio performance it is important to note that the VBATRCVR power supply must be connected differently, depending on whether the output driver or the analog outputs are being used:

- When using the analog outputs, VBATRCVR must be connected to VDDA on the application PCB
- When using the output driver, VBATRCVR must be connected to VBAT on the application PCB and must be decoupled with an external capacitor

When interfacing BelaSigna R261 with other processors like codecs or baseband chipsets, it is not recommended to use the output driver, but rather the analog outputs.

Clock Generation Circuitry

BelaSigna R261 is equipped with a fully configurable and flexible clocking system, which allows for a large number of clocking configurations for various use cases. Computing applications would typically require the use of a DMIC interface, which imposes constraints on the BelaSigna R261 clocking system, such as it provides full synchronization between an incoming DMIC clock and the DMIC data that the chip will produce. The clock frequencies that these systems usually operate with are in the range of 2.048 to 3.072 MHz. Mobile phone applications would typically use much higher clock frequencies; historically, baseband systems have been using 13 MHz or 26 MHz, or even 19.2 MHz or 38.4 MHz.

To support such a wide variety of clocking scenarios, BelaSigna R261 has a phase locked loop (PLL) integrated as one of the components of its clock generation circuitry. This highly configurable PLL is shown in Figure 15, in the context of the BelaSigna R261 clocking architecture.

BelaSigna R261

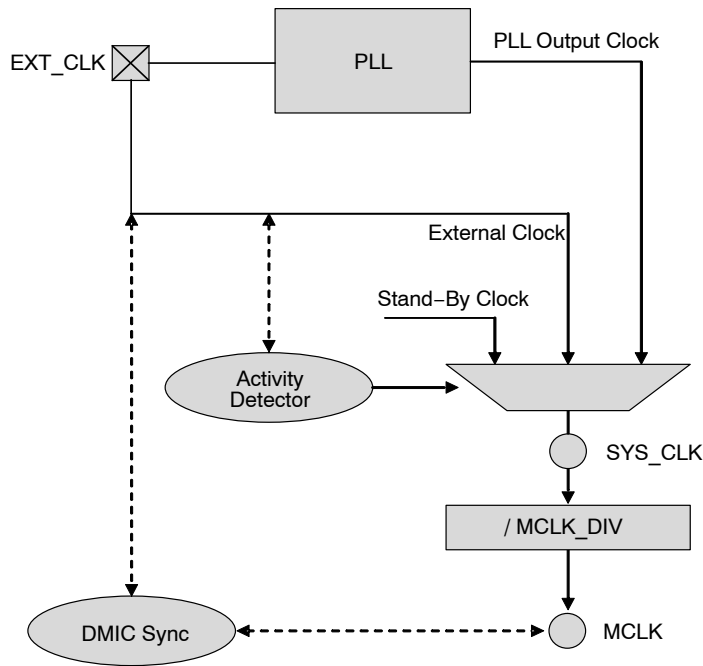

Figure 15. Clocking Circuitry

The ROM-based application pre-configures the clocking system in the various hardware presets that are available as described in Table 10, but for extended flexibility, the use of a custom application allows changing the clocking configuration to accommodate specific application needs. See the BelaSigna R261 Configuration and Communications Guide for more information.

SYS_CLK is the clock signal that will be used by the digital signal processing engine inside BelaSigna R261. It can be either the output of the PLL, as described above or it can also be driven by the stand-by clock, which is a very low frequency signal used to minimize power consumption in Sleep mode. Alternatively, the EXT_CLK signal could also be used directly by the system, bypassing the internal PLL.

MCLK is the clock signal that is used by the input and output stages of BelaSigna R261. MCLK must be configured to stay within the 1.92 MHz – 3.84 MHz range, to guarantee correct system operation. Among other parameters, an important impact of the MCLK signal is the sampling rate.

When the DMIC interface has to be used, BelaSigna R261 automatically synchronizes the EXT_CLK signal and the MCLK signal, as shown in Figure 15. Since MCLK is used

to generate the DMIC data output, it must be fully synchronized with the EXT_CLK signal (which is the DMIC clock) such that the DMIC host can properly sample the DMIC data. Consequently, the range of supported DMIC clock frequencies is the same as the MCLK range, i.e. 1.92 MHz to 3.84 MHz.

As discussed in the System Monitoring section, BelaSigna R261 is equipped with a clock detection mechanism that will permanently monitor activity on the EXT_CLK signal. This will ensure that whenever this clock source disappears, BelaSigna R261 will properly enter a known state, using an internal clocking signal, until the external clock comes back.

It should be noted that the internal PLL of BelaSigna R261 has a free-running mode, whereby it is capable to operate without an external clock reference. This mode requires special configuration, but can be used when it is not necessary to guarantee an exact clock frequency or when the sampling rate accuracy isn't important.

For more information on the configuration of this clocking architecture, refer to the BelaSigna R261 Configuration and Communications Guide.

BelaSigna R261

Power Supply Unit

BelaSigna R261 uses multiple power supplies as can be seen on the simplified representation of the power supply unit in Figure 16.

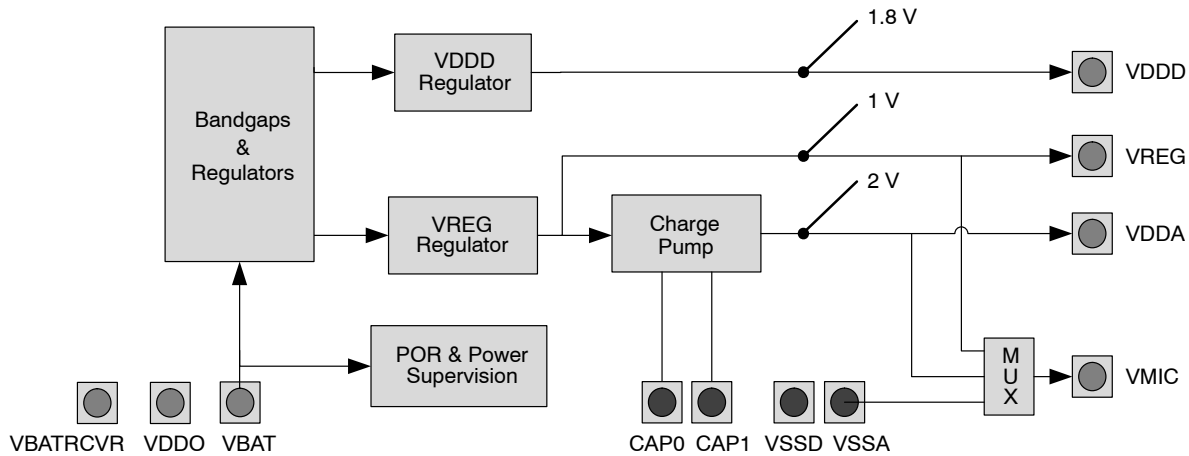

Figure 16. Power Supply Structure

Digital and analog sections of the chip have their own power supplies to allow exceptional audio quality. Several band gap reference circuits and voltage regulators are used to separate the power supplies to the various blocks that compose the BelaSigna R261 architecture.

Table 15 provides a short description of all the power supply pins of BelaSigna R261.

Table 15. POWER SUPPLY VOLTAGES

Voltage	Abbreviation	Description
Battery Supply Voltage	VBAT	The primary voltage supplied to BelaSigna R261 is VBAT. It is typically in the range 1.8 V – 3.3 V. BelaSigna R261 has internal voltage regulators, that allow the application PCB to avoid the use of external voltage regulators.
Output Driver Supply Voltage	VBATRCVR	If powered independently and the output driver is to be used, VBATRCVR must be connected to VBAT on the application PCB. Alternatively, if the analog outputs are used, VBATRCVR should be connected to VDDA.
Internal Digital Supply Voltage	VDDD	The internal digital supply voltage is used as the supply voltage for all internal digital components, including being used as the interface voltage at the internal side of the level translation circuitry attached to all of the digital pins. VDDD is provided as an output pad, where a decoupling capacitor to ground must be placed to filter power supply noise.
External I/O Supply Voltage	VDDO	VDDO is an externally provided power source. It is used by BelaSigna R261 as the external side of the level translation circuitry attached to all of the digital pins. Communication with external devices on digital pins will happen at the level defined on this pin.
Regulated Supply Voltage	VREG	VREG is a 1 V reference to the analog circuitry. It is available externally to allow for additional noise filtering of the regulated voltages within the system. VREG can also be used as a microphone power supply, when the VMIC pin cannot be used.
Analog Supply Voltage	VDDA	VDDA is a 2 V reference voltage generated from the internal charge pump. It is a reference to the analog circuitry. It is available externally to allow for additional noise filtering of the regulated voltages within the system. The internal charge pump uses an external capacitor that is periodically refreshed to maintain the 2 V supply. VDDA can also be used as a microphone power supply, when the VMIC pin cannot be used.
Microphone Bias Voltage	VMIC	VMIC is a configurable microphone bias voltage. VMIC can be configured by the application to provide 1 V or 2 V power supply to the microphones. It can also be grounded or put to High-Z mode to save power when the microphones don't have to be used. The ROM-based application configures VMIC to provide 2 V to the microphones when they are in use, and High-Z when the system is in Sleep mode.

Power Management Strategy & Battery Monitoring

BelaSigna R261 has a built-in power management unit that guarantees valid system operation under any voltage supply condition to prevent any unexpected audio output as the result of any supply irregularity. The unit constantly monitors the power supply and shuts down all functional units (including all units in the audio path) when the power supply voltage goes below a level at which point valid operation can no longer be guaranteed.

The power management unit on BelaSigna R261 includes power-on-reset (POR) functionality as well as power supervisory circuitry, as shown in Figure 16. These two components work together to ensure proper device operation under all battery conditions.

The POR sequence is designed to ensure proper system behavior during start-up and proper system configuration after start-up. At the start of the POR sequence, the audio output is disabled and all configuration and control registers are asynchronously reset to their default values.

The power supervisory circuitry monitors the battery supply voltage (VBAT). This circuit is used to start the system when VBAT reaches a safe startup voltage, and to reset the system when it drops below a relevant voltage threshold. The relevant parameters are shown in Table 16.

Table 16. POWER MANAGEMENT PARAMETERS

Parameters	Voltage Level
VBAT startup	1.65 V \pm 80 mV
VBAT shutdown	1.6 V \pm 50 mV

The POR sequence consists of two phases: voltage supply stabilization and boot ROM initialization. During the voltage supply stabilization phase, the following steps are performed:

1. The internal regulators are enabled and allowed to stabilize
2. The internal charge pump is enabled and allowed to stabilize
3. SYSCLK is connected to all of the system components (Free-running PLL output)
4. The system runs the ROM application

At step 1, once the supply voltage rises above the startup voltage and remains there for more than 5 ms, a signal will enable the charge pump.

At step 2, another 5 ms delay is implemented to allow the charge pump to stabilize before toggling the POR signal, and thus enabling the digital core.

If the supply is consistent, the internal system voltage will then remain at a fixed nominal voltage. If a spike occurs that causes the voltage to drop below the shutdown internal system voltage, the system will shut down. If the voltage rises again above the startup voltage and remains there for the required time, a POR sequence will occur again.

Once the ROM application is running, more system monitoring is performed by the application; typically, the software will permanently monitor the presence of an external

clock, and take the appropriate actions whenever it disappears. See the system monitoring section for more information.

Digital Communication Interfaces

Debug Port (UART)

BelaSigna R261 has an RS232-based UART that can be used to interface the chip from ON Semiconductor's communication tools. The debug port cannot be used for customer applications. BelaSigna R261 can only be configured using the I²C interface. See the I²C interface section for information on how communication tools can interface with BelaSigna R261.

General-Purpose Input Output (GPIO)

BelaSigna R261 has five GPIO pins which are all used with specific functionalities. The five signals are SPI_CLK/CONFIG_SEL, SPI_CS/ATT_SEL, SPI_SERO/ALGO_CTRL, SPI_SERI/SLEEP_CTRL and BOOT_SEL.

The BOOT_SEL pin controls the behavior of the four other GPIOs, as defined in the Booting Control section. When not used as an SPI port, these four other pins will act as GPIOs (ALGO_CTRL and SLEEP_CTRL) or as LSADs (ATT_SEL and CONFIG_SEL).

When used as GPIOs, all pins have pull-up resistors (BOOT_SEL, SLEEP_CTRL and ALGO_CTRL). When used as LSADs (ATT_SEL and CONFIG_SEL), the pull-ups are disabled. If left floating in LSAD mode, the pins have a weak pull-down to ground.

See the Booting Control, Sleep Mode Control and Algorithm Control sections earlier in this document for details on the behavior of these GPIO pins.

Serial Peripheral Interface (SPI) Port

An SPI port is available on BelaSigna R261 for applications such as communication with a non-volatile memory (EEPROM). The I/O levels on this port are defined by the voltage on the VDDO pin. The SPI port operates in master mode only, which supports communications with slave SPI devices. The four signals needed by the SPI port are multiplexed with other functions on BelaSigna R261 (GPIOs, LSADs). The use of the SPI port requires extreme care with regards to the use of these other functions.

I²C Interface

The I²C interface is an industry-standard interface that can be used for high-speed transmission of data between BelaSigna R261 and an external device. The interface operates at speeds up to 400 kbit/sec. In product development mode, the I²C interface is used for application debugging purposes, communicating with the BelaSigna R261 development tools, also known as SignaKlara Development Utility (SKDU). The interface always operates in slave mode and the slave address is 0x61.

A comprehensive command interface can be used with the SKDU. It will offer a variety of support functions grouped

BelaSigna R261

in different categories like general system control (system reset, status information), application control (switching between operating modes, enabling or disabling the algorithm), hardware setup (for custom configuration of the various hardware units like clocking, input/output stages), algorithm setup (amplitude management, custom algorithm mode loading) and finally the low-level I²C protocol is also supported. More details on this command interface can be found in the BelaSigna R261 Configuration and Communications Guide.

Interfaces Unused by the ROM-based Application

BelaSigna R261 also contains hardware provisions for a high speed PCM interface, as well as a high speed UART. These two interfaces are not used by the ROM-based application, hence cannot be used by default. Custom applications developed by ON Semiconductor could enable the use of these interfaces, should this be required.

Long Term Storage Conditions

ON Semiconductor specifies a 24-month maximum storage time for WLCSP devices in pocket tapes and conditioned in dry bags, as stated in Table 17 below and defined by ON Semiconductor's guidelines on long term storage.

Table 17. LONG TERM STORAGE CONDITIONS

Storage Condition	Maximum Storage Time	Remarks
Temperature 18–28°C, Humidity 30–65%RH	24 months after die singulation/sawing date	Maximum 12 months storage at condition 18–28°C, 30–65%RH. Afterwards storage in vacuum moisture bag with desiccant and humidity card. Storage in nitrogen cabinet allowed.

Re-Flow Information

The re-flow profile depends on the equipment that is used for the re-flow and the assembly that is being re-flowed. Care must be taken not to expose the packages to temperatures above the rated features. The WLCSP package is tested to perform reliably up to 3x reflow passes at the maximum reflow peak temperature of 260°C. Use Table 18 from the JEDEC Standard 22–A113D and J–STD–020D as a guideline but note that actual profiles should be developed by customers based on specific process needs and board designs.

Table 18. RE-FLOW INFORMATION

Profile Feature	Pb-free Assembly
Preheat & Soak Temperature minimum (TSMIN) Temperature maximum (TSMAX) Time (TSMIN to TSMAC) (TS)	150°C 200°C 60–120 seconds
Average Ramp-Up Rate (TSMAX to TP)	3°C/second maximum
Liquidous temperature and time Temperature (TL) Time (tL)	217°C 60–150 seconds
Peak Temperature (TP)	260 +0/–5°C
Time within 5°C of Actual Peak Temperature	20–40 seconds
Ramp-Down Rate (TP to TSMAX)	6°C/second maximum
Time 25°C to Peak Temperature	8 minutes maximum

Device Weight

BelaSigna R261 has an average weight of 0.011 grams.

Miscellaneous

Chip Identification

Chip identification information can be retrieved by using the Communications Accelerator Adaptor (CAA) along with protocol software provided by ON Semiconductor. For BelaSigna R261, the key identifier components and values are as follows:

Chip Family	Chip Version
0x02 (SK2)	0x3010

BelaSigna R261

PACKAGE DIMENSIONS

WLCSP30, 2.233x2.388
CASE 567CT
ISSUE A

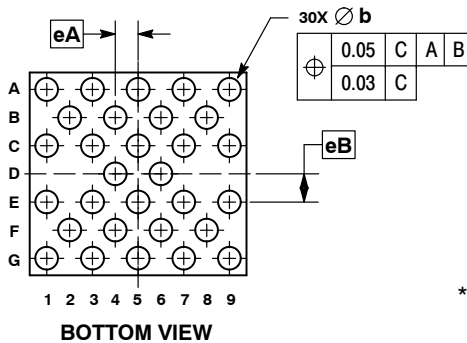
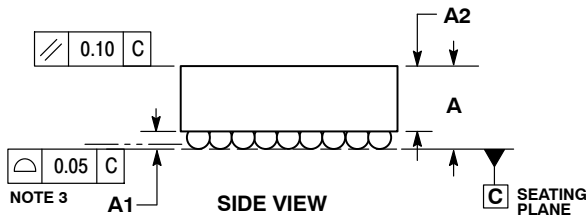
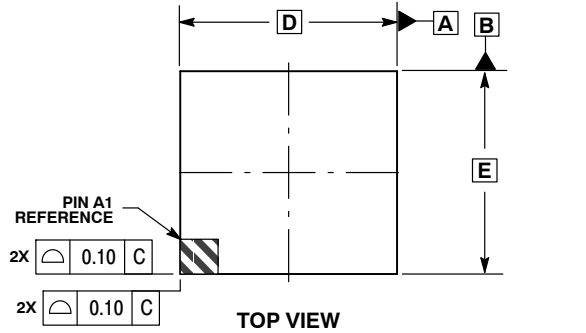

NOTES:

1. DIMENSIONING AND TOLERANCING PER ASME Y14.5M, 1994.
2. CONTROLLING DIMENSION: MILLIMETERS.
3. COPLANARITY APPLIES TO SPHERICAL CROWNS OF SOLDER BALLS.

DIM	MILLIMETERS	
	MIN	MAX
A	0.84	1.00
A1	0.17	0.23
A2	0.72	REF
b	0.24	0.29
D	2.388 BSC	
E	2.233 BSC	
eA	0.252 BSC	
eB	0.310 BSC	

RECOMMENDED SOLDERING FOOTPRINT*

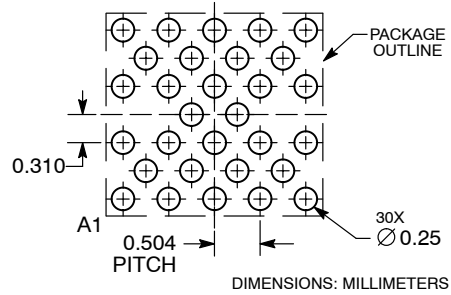

*For additional information on our Pb-Free strategy and soldering details, please download the ON Semiconductor Soldering and Mounting Techniques Reference Manual, SOLDERRM/D.

BelaSigna R261

PACKAGE DIMENSIONS

WLCSP26, 2.388x2.233
CASE 567CY
ISSUE A

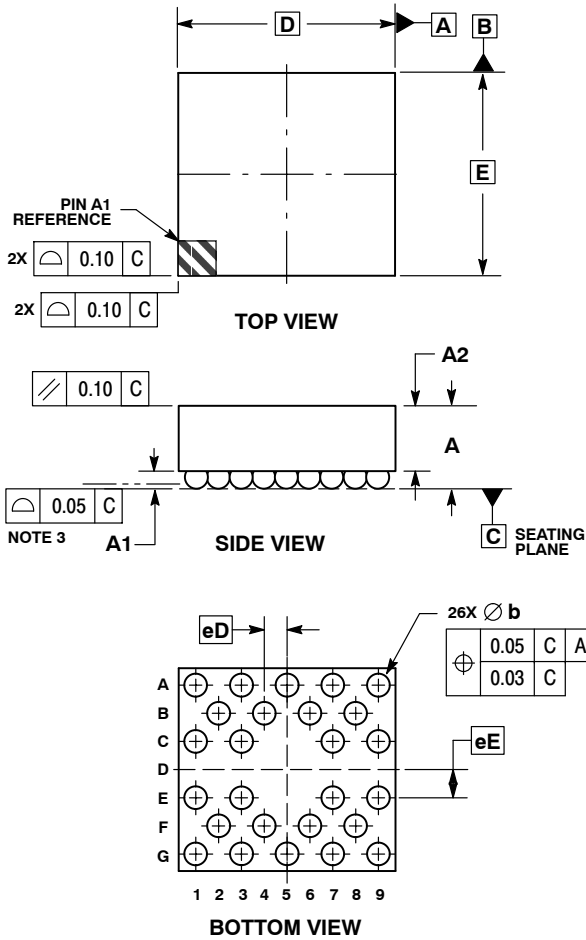

- NOTES:
1. DIMENSIONING AND TOLERANCING PER ASME Y14.5M, 1994.
 2. CONTROLLING DIMENSION: MILLIMETERS.
 3. COPLANARITY APPLIES TO SPHERICAL CROWNS OF SOLDER BALLS.

MILLIMETERS		
DIM	MIN	MAX
A	0.84	1.00
A1	0.17	0.23
A2	0.72	REF
b	0.24	0.29
D	2.388	BSC
E	2.233	BSC
eD	0.252	BSC
eE	0.310	BSC

RECOMMENDED SOLDERING FOOTPRINT*

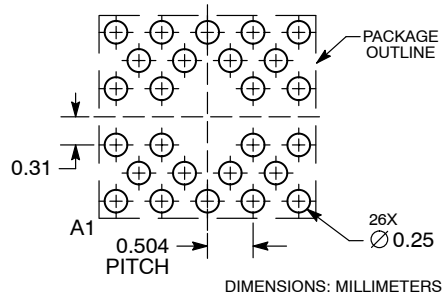

*For additional information on our Pb-Free strategy and soldering details, please download the ON Semiconductor Soldering and Mounting Techniques Reference Manual, SOLDERRM/D.

BelaSigna R261

Assembly / Design Notes

For PCB manufacture with BelaSigna R261, ON Semiconductor recommends solder-on-pad (SoP) surface finish. With SoP, the solder mask opening should be non-solder mask-defined (NSMD) and copper pad geometry will be dictated by the PCB vendor's design requirements.

Alternative surface finishes are ENiG and OSP; volume of screened solder paste (#5) should be less than 0.0008 mm³. If no pre-screening of solder paste is used, then the following conditions must be met:

1. The solder mask opening should be >0.3 mm in diameter
2. The copper pad should have a diameter of 0.25 mm

3. Solder mask thickness should be less than 1 mil thick above the copper surface

For PCB manufacture with the 26-ball version of BelaSigna R261, any vias that might be placed below the WLCSP should all be covered in soldermask. The assembly process can use underfill under the WLCSP; it will provide another physical dielectric barrier, and will also enhance long term reliability over temperature and physical shock.

ON Semiconductor can provide BelaSigna R261 mounting footprint guidelines to assist your PCB design upon request.

Table 19. ORDERING INFORMATION

Device	Marking	Package	Shipping †
BR261W30A101E1G	BR261W30	WLCSP30	2500 / Tape & Reel
BR261W26A101E1G	BR261W26	WLCSP26	2500 / Tape & Reel

†For information on tape and reel specifications, including part orientation and tape sizes, please refer to our Tape and Reel Packaging Specification Brochure, BRD8011/D.

BELASIGNA is a registered trademark of Semiconductor Components Industries, LLC.

ON Semiconductor and  are registered trademarks of Semiconductor Components Industries, LLC (SCILLC). SCILLC owns the rights to a number of patents, trademarks, copyrights, trade secrets, and other intellectual property. A listing of SCILLC's product/patent coverage may be accessed at www.onsemi.com/site/pdf/Patent-Marking.pdf. SCILLC reserves the right to make changes without further notice to any products herein. SCILLC makes no warranty, representation or guarantee regarding the suitability of its products for any particular purpose, nor does SCILLC assume any liability arising out of the application or use of any product or circuit, and specifically disclaims any and all liability, including without limitation special, consequential or incidental damages. "Typical" parameters which may be provided in SCILLC data sheets and/or specifications can and do vary in different applications and actual performance may vary over time. All operating parameters, including "Typicals" must be validated for each customer application by customer's technical experts. SCILLC does not convey any license under its patent rights nor the rights of others. SCILLC products are not designed, intended, or authorized for use as components in systems intended for surgical implant into the body, or other applications intended to support or sustain life, or for any other application in which the failure of the SCILLC product could create a situation where personal injury or death may occur. Should Buyer purchase or use SCILLC products for any such unintended or unauthorized application, Buyer shall indemnify and hold SCILLC and its officers, employees, subsidiaries, affiliates, and distributors harmless against all claims, costs, damages, and expenses, and reasonable attorney fees arising out of, directly or indirectly, any claim of personal injury or death associated with such unintended or unauthorized use, even if such claim alleges that SCILLC was negligent regarding the design or manufacture of the part. SCILLC is an Equal Opportunity/Affirmative Action Employer. This literature is subject to all applicable copyright laws and is not for resale in any manner.

PUBLICATION ORDERING INFORMATION

LITERATURE FULFILLMENT:
Literature Distribution Center for ON Semiconductor
P.O. Box 5163, Denver, Colorado 80217 USA
Phone: 303-675-2175 or 800-344-3860 Toll Free USA/Canada
Fax: 303-675-2176 or 800-344-3867 Toll Free USA/Canada
Email: orderlit@onsemi.com

N. American Technical Support: 800-282-9855 Toll Free
USA/Canada
Europe, Middle East and Africa Technical Support:
Phone: 421 33 790 2910
Japan Customer Focus Center
Phone: 81-3-5817-1050

ON Semiconductor Website: www.onsemi.com
Order Literature: <http://www.onsemi.com/orderlit>
For additional information, please contact your local Sales Representative