

# ON Semiconductor

## Is Now

# onsemi™

To learn more about onsemi™, please visit our website at  
[www.onsemi.com](http://www.onsemi.com)

---

**onsemi** and **onsemi** and other names, marks, and brands are registered and/or common law trademarks of Semiconductor Components Industries, LLC dba "**onsemi**" or its affiliates and/or subsidiaries in the United States and/or other countries. **onsemi** owns the rights to a number of patents, trademarks, copyrights, trade secrets, and other intellectual property. A listing of **onsemi** product/patent coverage may be accessed at [www.onsemi.com/site/pdf/Patent-Marking.pdf](http://www.onsemi.com/site/pdf/Patent-Marking.pdf). **onsemi** reserves the right to make changes at any time to any products or information herein, without notice. The information herein is provided "as-is" and **onsemi** makes no warranty, representation or guarantee regarding the accuracy of the information, product features, availability, functionality, or suitability of its products for any particular purpose, nor does **onsemi** assume any liability arising out of the application or use of any product or circuit, and specifically disclaims any and all liability, including without limitation special, consequential or incidental damages. Buyer is responsible for its products and applications using **onsemi** products, including compliance with all laws, regulations and safety requirements or standards, regardless of any support or applications information provided by **onsemi**. "Typical" parameters which may be provided in **onsemi** data sheets and/or specifications can and do vary in different applications and actual performance may vary over time. All operating parameters, including "Typicals" must be validated for each customer application by customer's technical experts. **onsemi** does not convey any license under any of its intellectual property rights nor the rights of others. **onsemi** products are not designed, intended, or authorized for use as a critical component in life support systems or any FDA Class 3 medical devices or medical devices with a same or similar classification in a foreign jurisdiction or any devices intended for implantation in the human body. Should Buyer purchase or use **onsemi** products for any such unintended or unauthorized application, Buyer shall indemnify and hold **onsemi** and its officers, employees, subsidiaries, affiliates, and distributors harmless against all claims, costs, damages, and expenses, and reasonable attorney fees arising out of, directly or indirectly, any claim of personal injury or death associated with such unintended or unauthorized use, even if such claim alleges that **onsemi** was negligent regarding the design or manufacture of the part. **onsemi** is an Equal Opportunity/Affirmative Action Employer. This literature is subject to all applicable copyright laws and is not for resale in any manner. Other names and brands may be claimed as the property of others.

## KNX Family: Guidelines for Porting NCN5120 to NCN5110/21/30 Transceivers ICs



ON Semiconductor®

[www.onsemi.com](http://www.onsemi.com)

### APPLICATION NOTE

#### Introduction

NCN5120 and NCN5110/5121/5130 are receivers–transmitters ICs suitable for use in KNX twisted pair networks (KNX TP1–256). They support the connection of actuators, sensors, microcontrollers, switches or other applications in a building network.

NCN51xx ICs handle the transmission and reception of data on the bus. They generate their own power supplies, as well as power for external devices, from the unregulated bus voltage.

The goal of this Application Note is to present the main differences between the KNX family members and how to shift a design between the different ICs depending on design’s needs and usages.

The first part of this application note will highlight the differences between all those ICs. Then the 2<sup>nd</sup> part of the

application note will help a designer to identify the schematics/BoM change required to move from one part to another.

#### NCN51xx Family ICs Features

Latest platform new IC family is composed of 3 products: NCN5110, NCN5121 and NCN5130.

NCN5110 is an analog only IC, in charge of the physical transmission over the KNX twisted pair network. It acts as a bit transceiver. The MAC layer being pushed to the micro–controller connected to the NCN5110.

NCN5121 is a pin–to–pin part replacement of NCN5120 with the same set of improved features.

NCN5130 is a full feature device for new design.

For more information please refer to the datasheets of the components available on ON Semiconductor website.

	NCN5120	NCN5121	NCN5110	NCN5130
Efficiency Increase		✓	✓	✓
10/20 mA Bus Current Consumption	✓	✓		
5 to 40 mA Bus Current Consumption			✓	✓
KNX Bus Current Limit		✓	✓	✓
PHY + MAC Layer (TPUART function)	✓	✓		✓
PHY Layer (analog only)			✓	
3.3 V Fixed DC/DC	✓	✓	✓	✓
Variable DC/DC	✓	✓	✓	✓
20 V LDO	✓	✓	✓	✓
Analog Monitor Output		✓		✓
Extended Temperature Range		✓	✓	✓

# AND9289/D

## BLOCK DIAGRAM COMPARISON

Main changes between NCN5120 & NCN5110/21/30 are:

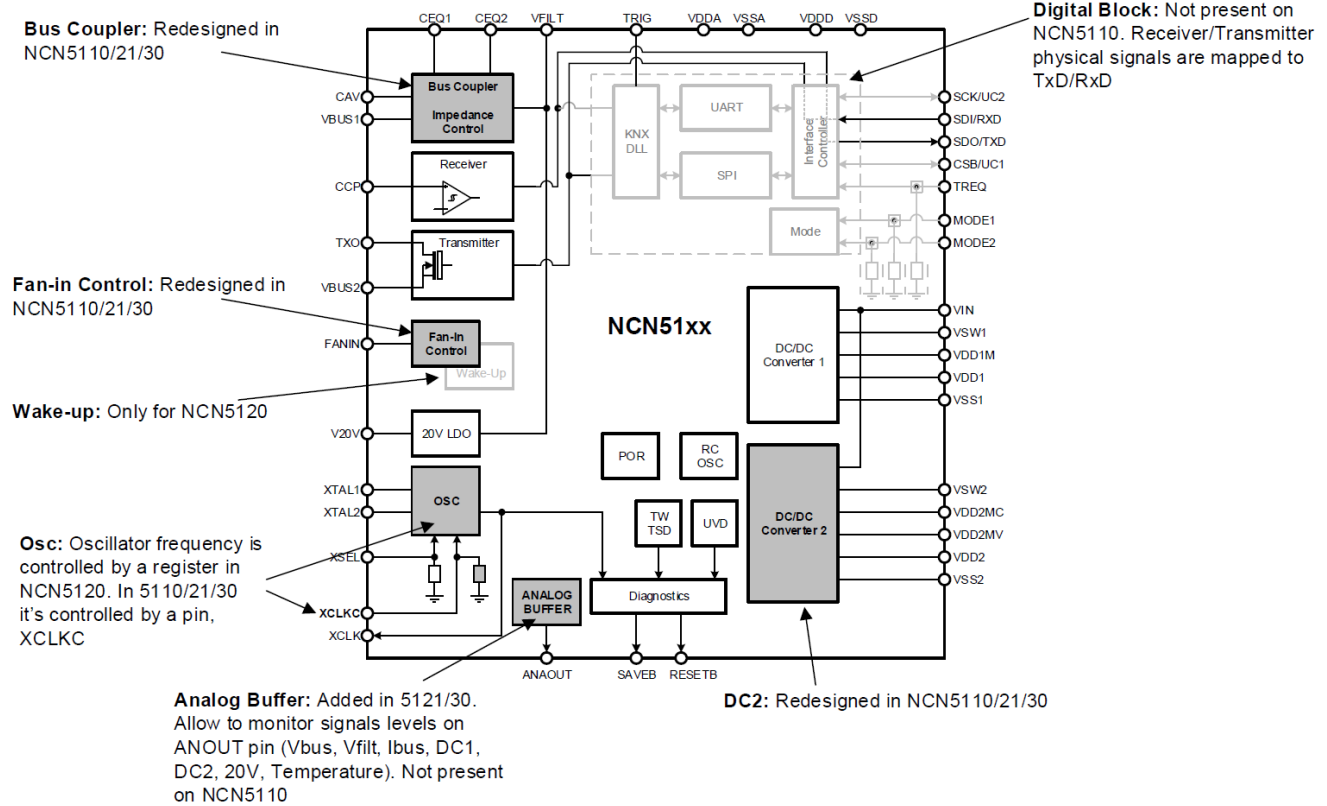

Figure 1. NCN 51xx Block Diagram

### Oscillator

Oscillator block has been modified. Oscillator frequency (8/16 MHz) was previously controlled by a register for NCN5120. Now on NCN5110/21/30 it is controlled by a pin, XCLKC (pin 21), that was not connected in NCN5120. If XCLKC is connected to ground (or not connected) then an 8 MHz clock signal is present on XCLK. If XCLKC is connected to Vdd then a 16 MHz clock signal is present on XCLK.

### Configuration

NCN5120/21/30 can be configured by registers that can be accessed through UART or SPI interface.

Registers allow to:

- Enable/disable DC2, 20 V LDO, Clock output
- Set the signal to be monitored on ANAOUT pin
- Configure/Set watchdog
- ...

On NCN5110:

- Enable/Disable of DC2 is driven by pin 29 (nDC2EN-pin)
- Enable/Disable of 20 V LDO is driven by pin 26 (nV20Ven)

## AND9289/D

**Table 1. MAIN FEATURES LIST COMPARISON**

	<b>NCN5120</b>	<b>NCN5121</b>	<b>NCN5110</b>	<b>NCN5130</b>
<b>Main Application</b>		Part replacement for NCN5120 (recommended for new design)	Analog only mode (Bit Transceiver)	Full feature
<b>Bus Coupler Current Consumption</b>	2 discrete models: 10 or 20 mA	2 discrete models: 10 or 20 mA	– 2 discrete models: 10 or 20 mA – Analog model from 5 to 40 mA (additional resistor)	– 2 discrete models: 10 or 20 mA – Analog model from 5 to 40 mA (additional resistor)
<b>Bus Coupler Current limitation</b>	No current limitation	Current limitation (based on bus coupler current consumption model)	Current limitation (based on bus coupler current consumption model)	Current limitation (based on bus coupler current consumption model)
<b>Bus Coupler Voltage Drop (Bus current consumption)</b>	3.5 V Typ. (at 12 mA) 8 V Max. (at 24 mA)	1.75 V Typ. (at 10 mA) 2.8 V Max. (at 20 mA)	1.75 V Typ. (at 10 mA) 4.05 V Max.(at 40 mA)	1.75 V Typ. (at 10 mA) 4.05 V Max.(at 40 mA)
<b>Bus Current Consumption (50% comm. on the bus)</b>	5 mA typ.	2.7 mA typ.	2.5 mA typ.	2.7 mA typ.
<b>Bus Current Consumption (No comm. on the bus)</b>	3.6 mA typ.	2.5 mA typ.	2.3 mA typ.	2.5 mA typ.
<b>DC/DC1 DC/DC2</b>	3.3 V Fixed 3.3–21 V Selectable	3.3 V Fixed 1.2–21 V Selectable	3.3 V Fixed 1.2–21 V Selectable	3.3 V Fixed 1.2–21 V Selectable
<b>20V LDO output current</b>	4 mA typical ~11 mA max	~24 mA max Current limitation configurable per register	~37 mA max	~48mA max Current limitation configurable per register
<b>DC2/20V Enable/Disable</b>	Configured by register	Configured by register	Configured by signals	Configured by register
<b>Temperature range</b>	–25°C to +85°C	–40°C to +105°C	–40°C to +105°C	–40°C to +105°C

# AND9289/D

## TYPICAL BOM

The table below presents the difference in the bill of material between the different parts

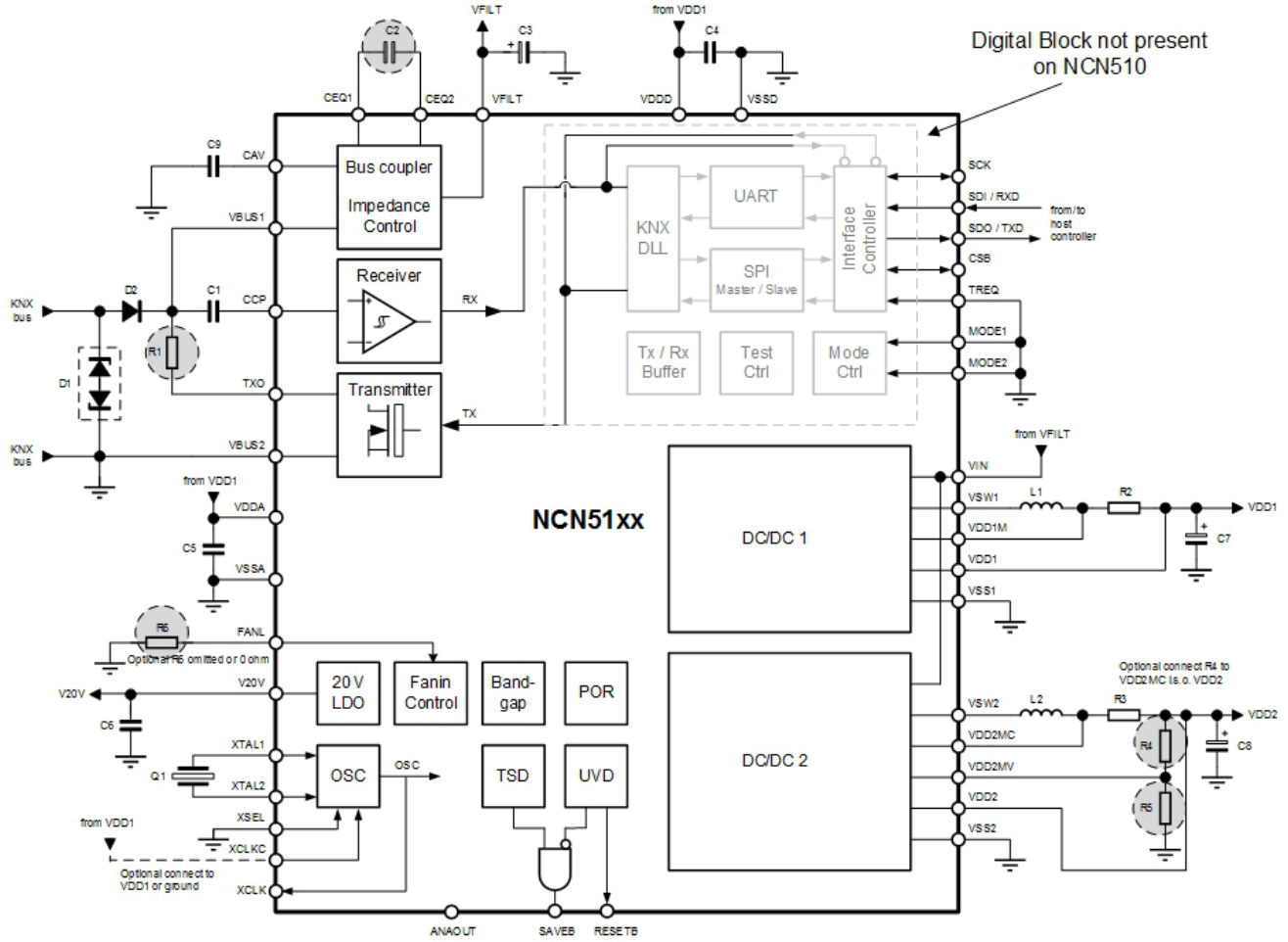

Figure 2. NCN51xx Typical BoM

## AND9289/D

**Table 2. TYPICAL BOM**

	Function	NCN5120	NCN5121	NCN5110	NCN5130	Tol.	Units
C1	AC coupling capacitor	47				±20%	nF
C2	Energy conservation capacitor	4.7 (±10%)	220 (±20%)				nF
C3	Storage and Filter capacitor	100				±20%	uF
C4	HF rejection capacitor at VDDD	100				±20%	nF
C5	HF rejection capacitor at VDDA	100				±20%	nF
C6	Load capacitor V20V	1				±10%	μF
C7	Load capacitor VDD1	10				±20	μF
C8	Load capacitor VDD2	10				±20	μF
C9	Bus current slope capacitor	100				±20%	nF
R1	Shunt resistor for transmitting	22	27			±10%	Ω
R2	DC1 sensing resistor	1				±5%	Ω
R3	DC2 sensing resistor	1				±5%	Ω
R4/R5	DC2 voltage divider	Calculation (Note 2)					
R6	Fan-in resistor	N/A (Note 3)		10 – 93.1 (Note 3)		±1%	KΩ
L1/L2	DC1/DC2 Coil	220				±20%	μH
D1	Voltage suppressor	1SAM40CA					
D2	Reverse polarity protection diode	SS16					
Q1	Crystal oscillator	16		Omitted (optional) (Note 1)	16	50	ppm

1. Optional. Can be mounted if NCN5110 is used as to output a clock signal.
2. One formula for NCN5120. Formula is the same for NCN5110/NCN5121/NCN5130.
3. Only discrete mode for 5120/21 (connected to ground or not connected). Discrete or analog mode for 5110/30. Refer to Figures 3 and 4.

Bus Current Consumption & Limitation

At startup the bus current consumption profile,  $I_{BUS}$ , is as follow:

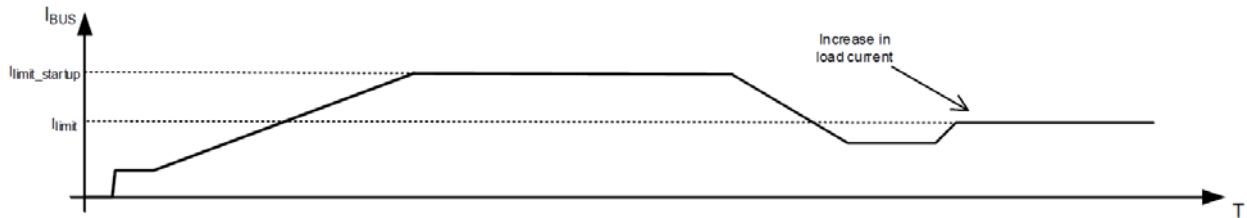

Figure 3. Ibus Profile

With  $I_{limit}$  and  $I_{limit\_startup}$  defined as:

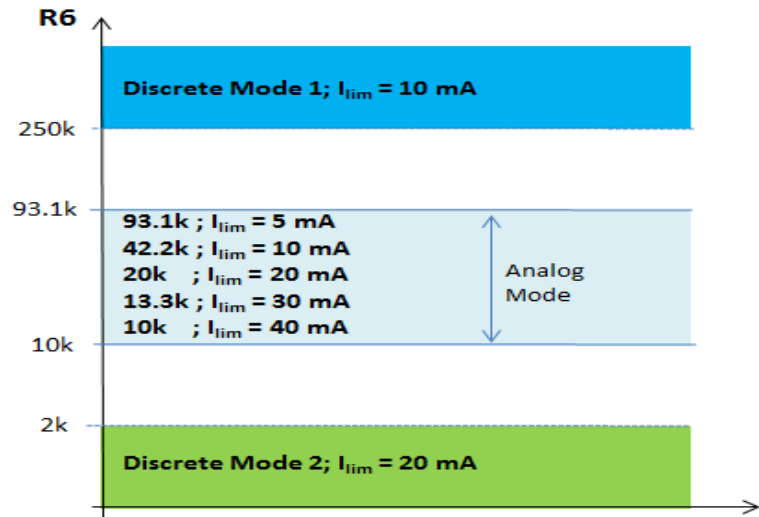
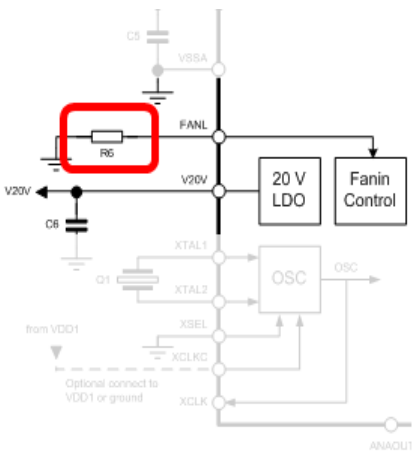

Figure 4.  $I_{lim}$  Value

With  $I_{limit\_startup}$  being approximately 2 times  $I_{limit}$ :

$$I_{limit\_startup} = 2 \times I_{limit}$$

In discrete mode mode the FANL pin should either be strapped to ground or kept floating.

## MOVING FROM NCN5120 TO NCN5110/21/30

**From NCN5120 to NCN5121**

NCN5121 can then be used as a part replacement for NCN5120. While strictly the same PCB layout can be used when migrating from NCN5120 to NCN5121, few minor modifications (mainly components value) are needed to migrate and benefit all new NCN5121 features.

Designer needs to pay attention to the BOM change as per Table 2:

- Wake-up functionality is no longer supported. So if used then layout has to be updated to remove it.
- Clock signal output on XCLK-pin is now controlled by XCLKC-pin. If XCLK-pin was used to feed a clock signal to host controller then attention needs to be paid on XCLKC-pin for frequency.
- The shunt resistor for transmitting (R1) is 27 Ohm.
- The energy conservation capacitor (C2) value has been changed from 4.7 nF to 220 nF/50 V
- If DC2 is used, then attention needs to be paid to the voltage divider (R4/R5). Resistors must be changed compared to NCN5120 to maintain the same divider value.

**From NCN5120 to NCN5110**

When NCN5120 is used in analog mode only (bit transceiver), NCN5110 can be used as a part replacement. While strictly the same PCB layout can be used when migrating from NCN5120 to NCN5110, few minor modifications (mainly components value) are needed to migrate and benefit all new NCN5110 features.

Designer needs to pay attention to the BOM change as per Table 2:

- Wake-up functionality is no longer supported. So if used then layout has to be updated to remove it.
- If crystal is not used to feed clock to another component (e.g.  $\mu\text{C}$ ), through XCLK-pin, then crystal can be omitted (Not populated).
- Clock signal output on XCLK-pin is now controlled by XCLKC-pin. If XCLK-pin was used to feed a clock signal to host controller then attention needs to be paid on XCLKC-pin for frequency.
- If DC2 is used, then attention needs to be paid to the voltage divider (R4/R5). Resistors must be changed to maintain the same divider value.

- The shunt resistor for transmitting (R1) is 27 Ohm.
- The bus current consumption limitation can be set in discrete mode, as for NCN5120 if strapped to GND or floating, but also in analog mode if R6 is used.
- The energy conservation capacitor (C2) value has been changed from 4.7 nF to 220 nF/50 V
- If DC2 and/or 20VLDO are not used, pins 26 & 29 are used to disable those blocks.

**From NCN5120 to NCN5130**

On new design NCN5130 can be used as a part replacement for NCN5120 to benefit the extra features brought by NCN5130 (see Table 1). The same PCB layout can be used while minor modifications on the BOM will benefit the improvements of NCN5130.

Designer needs to pay attention to the BOM change as per Table 2:

- Wake-up functionality is no longer supported. So if used then layout has to be updated to remove it.
- Clock signal output on XCLK-pin is now controlled by XCLKC-pin. If XCLK-pin was used to feed a clock signal to host controller then attention needs to be paid on XCLKC-pin for frequency.
- If DC2 is used, then attention needs to be paid to the voltage divider (R4/R5). To obtain the same divider value of resistors must be changed.
- The bus current consumption limitation can be set in discrete mode, as for NCN5120 if strapped to GND or floating, but also in analog mode if R6 is used.
- The shunt resistor for transmitting (R1) is 27 Ohm.
- The energy conservation capacitor (C2) value is 220 nF.

**New design in analog mode (bit transceiver)**

When starting a new design in analog mode NCN5110 is the preferred IC. Since the design is not digital and will not decode the symbol, there is no need for an external clock source. The crystal oscillator can then be omitted.

**New design in full feature mode**

If starting a new design in full feature mode, then, in order to benefit all the improvements of the new platform the layout and BOM should be modified according to Table 2.



ON Semiconductor and the  are registered trademarks of Semiconductor Components Industries, LLC (SCILLC) or its subsidiaries in the United States and/or other countries. SCILLC owns the rights to a number of patents, trademarks, copyrights, trade secrets, and other intellectual property. A listing of SCILLC's product/patent coverage may be accessed at [www.onsemi.com/site/pdf/Patent-Marking.pdf](http://www.onsemi.com/site/pdf/Patent-Marking.pdf). SCILLC reserves the right to make changes without further notice to any products herein. SCILLC makes no warranty, representation or guarantee regarding the suitability of its products for any particular purpose, nor does SCILLC assume any liability arising out of the application or use of any product or circuit, and specifically disclaims any and all liability, including without limitation special, consequential or incidental damages. "Typical" parameters which may be provided in SCILLC data sheets and/or specifications can and do vary in different applications and actual performance may vary over time. All operating parameters, including "Typicals" must be validated for each customer application by customer's technical experts. SCILLC does not convey any license under its patent rights nor the rights of others. SCILLC products are not designed, intended, or authorized for use as components in systems intended for surgical implant into the body, or other applications intended to support or sustain life, or for any other application in which the failure of the SCILLC product could create a situation where personal injury or death may occur. Should Buyer purchase or use SCILLC products for any such unintended or unauthorized application, Buyer shall indemnify and hold SCILLC and its officers, employees, subsidiaries, affiliates, and distributors harmless against all claims, costs, damages, and expenses, and reasonable attorney fees arising out of, directly or indirectly, any claim of personal injury or death associated with such unintended or unauthorized use, even if such claim alleges that SCILLC was negligent regarding the design or manufacture of the part. SCILLC is an Equal Opportunity/Affirmative Action Employer. This literature is subject to all applicable copyright laws and is not for resale in any manner.

## PUBLICATION ORDERING INFORMATION

### LITERATURE FULFILLMENT:

Literature Distribution Center for ON Semiconductor  
19521 E. 32nd Pkwy, Aurora, Colorado 80011 USA  
**Phone:** 303-675-2175 or 800-344-3860 Toll Free USA/Canada  
**Fax:** 303-675-2176 or 800-344-3867 Toll Free USA/Canada  
**Email:** [orderlit@onsemi.com](mailto:orderlit@onsemi.com)

**N. American Technical Support:** 800-282-9855 Toll Free  
USA/Canada  
**Europe, Middle East and Africa Technical Support:**  
Phone: 421 33 790 2910  
**Japan Customer Focus Center**  
Phone: 81-3-5817-1050

**ON Semiconductor Website:** [www.onsemi.com](http://www.onsemi.com)  
**Order Literature:** <http://www.onsemi.com/orderlit>  
For additional information, please contact your local  
Sales Representative