

A 60 W AC-DC Demonstrator with NCP1256



ON Semiconductor®

www.onsemi.com

APPLICATION NOTE

Housed in a tiny TSOP6 package, the NCP1256 lends itself very well to designing moderate to high output power converters. This application note demonstrates the part capabilities in a 60-W ac-dc adapter, typical of what is needed for the high-volume net/notebook market.

The Adapter Schematic

The adopted schematic appears in Figure 1. You can see the NCP1256 surrounded by components implementing brown-out sensing, over voltage and over temperature protection. We start the description by the left side of the board. The mains is applied on the rectifying diode bridge through an EMI filter made of a 10-mH common-mode choke. Its leakage inductance is used together with C_{11} to form a differential mode filter. Resistors (R_{15} , R_{27} , R_{17} and R_{20}) perform the dual function of brown-out sensing and also ensure the discharge of the X2-capacitor when the power cord is un-plugged. These resistors must be carefully selected to fulfill the IEC-950 safety standards as they can obviously hamper the no-load standby power. Additional filtering and protection devices can be necessary (VDR, spark-gaps) to improve the filter as you start qualifying the final prototype for safety and surge robustness. On the other hand, it is also possible to differently design the EMI filter to adopt an X2 capacitor of 0.1 μF . In this case, discharge resistors are no longer needed and brown-out sensing resistors can be slightly increased to the benefit of standby power.

The controller drives a 5 A/650 V power MOSFET with a small PNP transistor which helps reduce the turn-off event for an improved efficiency.

Start-Up and Self-Supply

The start-up network benefits from the very low current consumption of the NCP1256. With a 10 μA maximum current, the part can be cranked with a weak start-up current which is good for the standby power. For this demonstration board, we have adopted a capacitive start-up network implemented around C_{16} and C_{19} . The dissipation of this network is almost inexistent compared to a direct connection to the bulk capacitor for instance. Furthermore, in case of a latched event, the V_{CC} on the part will collapse at a faster pace when the user un-plugs the converter as no additional current can maintain the V_{CC} capacitor voltage on the controller. This is different from a situation where start-up

resistors are connected to the bulk capacitor which slowly discharges at power-off and maintains the voltage on the V_{CC} capacitor for a long time before reset occurs. In this circuit, the reset level is typically 250 mV below the UVLO level, considerably reducing the reset time at power off. If a slightly faster reset time is necessary, you can advantageously connect a 1 M Ω resistor from V_{CC} to ground: it will help the controller reset faster without bothering the capacitive start-up circuit. The selected network ensures a start-up sequence below 3 seconds at the lowest input line. We have tested this sequence with the board delivering 3 A while powered from a 85 V rms input voltage (Figure 2). In this worst case, the time at which the full output voltage is ready remains below the 3 s limit, giving some margin for the nominal case at 100 V rms. Please note that the various leakages to earth brought by the oscilloscope and other active loads have to be minimized during this test to avoid altering the start-up time.

The start-up sequence is linked to the V_{CC} capacitor value. A small value will bring a short start-up time but can possibly engender a hiccup at power-on. A sufficient level of energy must be stored in this capacitor as it is the only source of energy at power-on before the auxiliary winding takes over the controller's supply. In the NCP1256, the reason why the Under Voltage Lock Out (UVLO) has been placed high enough is to increase the available CV^2 term at UVLO high. This helps lower the storage capacitor value while improving the start-up time. Unfortunately, in these low-standby power supplies, the recurrence of the switching pulses in light load conditions can be very long. In this situation, as the refresh of the V_{CC} capacitor is made by bunches (the part operates in skip cycle) there are chances that the V_{CC} level slowly goes down until it touches the part's UVLO low level and initiates a new start-up sequence. If we grow the V_{CC} capacitor, the start-up time will suffer. A possible solution is that described in Figure 3. It consists of splitting the capacitors and isolating them via a simple diode.

AND9206/D

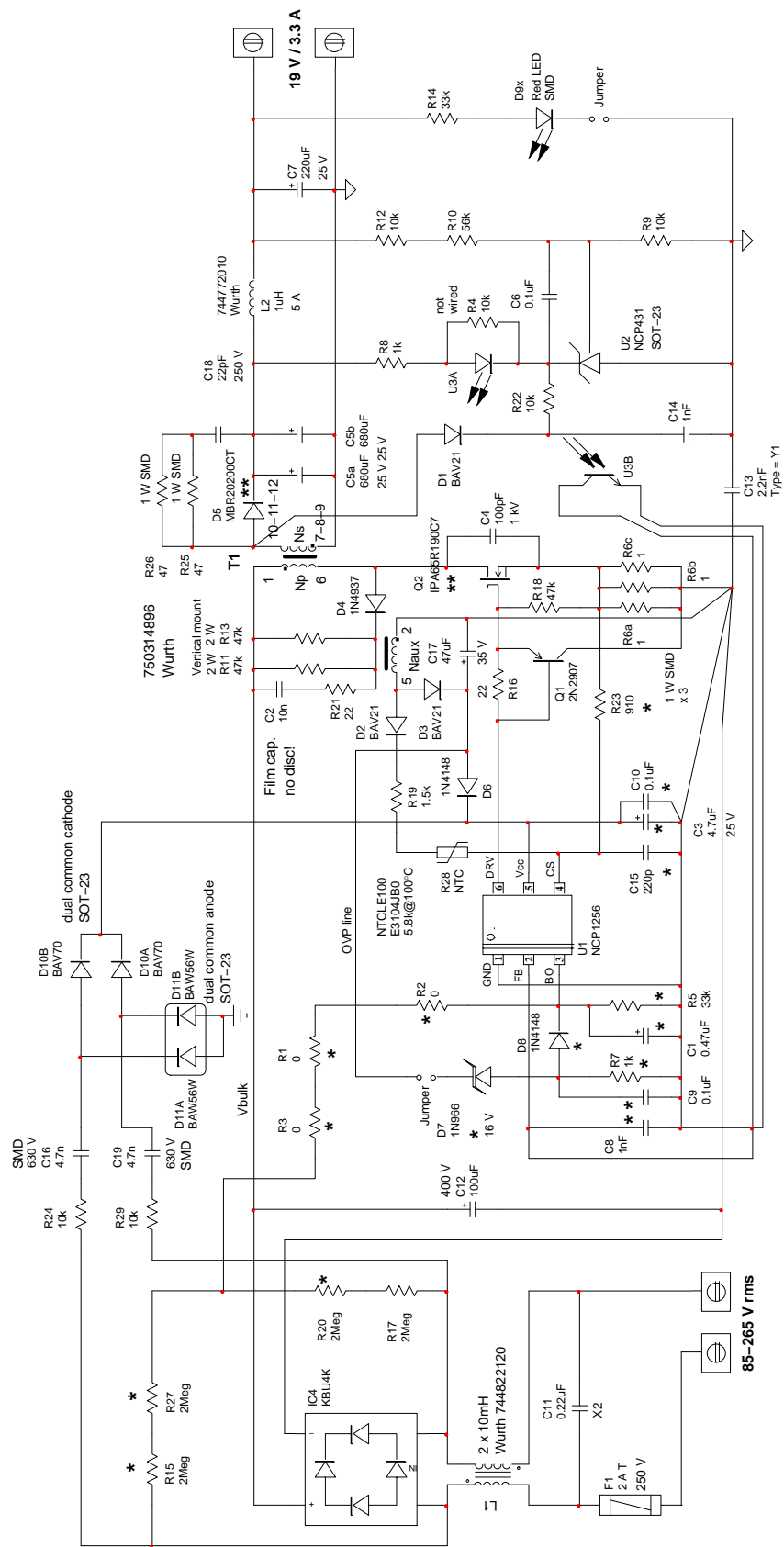

Figure 1. The Adapter Uses All the Features Brought by the NCP1256 to Implement a High-Performance 60 W Converter

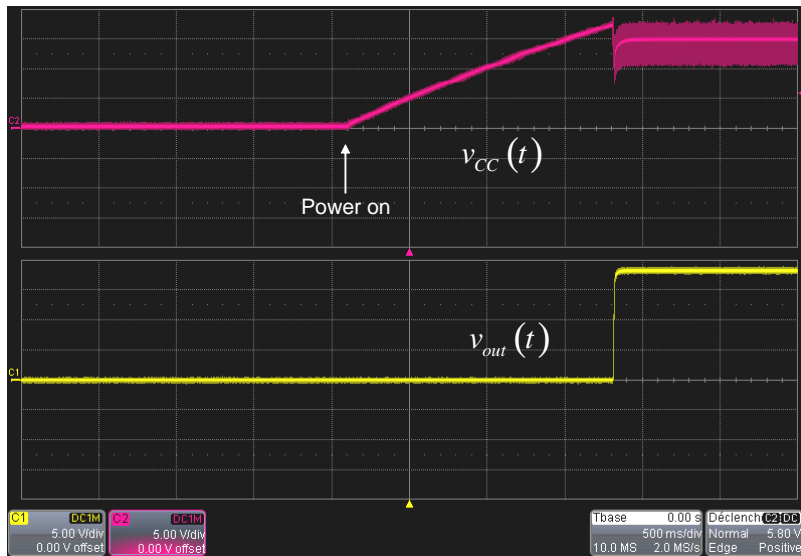

Figure 2. The Start-up Sequence is below 3 s when Powered from a 85 V rms Input Voltage while Delivering 3 A. Here with a Capacitive Start-up Circuit

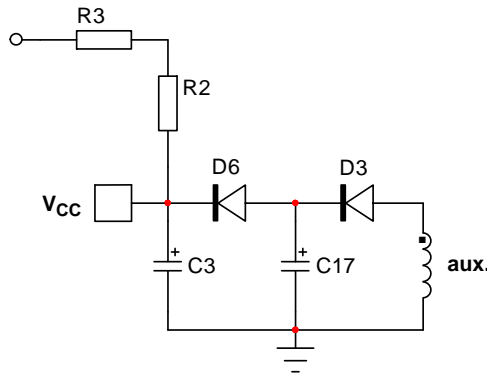

Figure 3. The Split Supply Lets you Power the Controller with a Small V_{CC} Capacitor, Decoupled from a Larger Value directly Connected to the Auxiliary Winding

In this case, the start-up time involves C_3 only as D_6 decouples the discharged capacitor C_{17} from the charging circuit. When the auxiliary winding charges C_{17} , the voltage across its terminals increases until it completely supplies the controller. In standby, the circuit is decoupled by a capacitor equal to $C_3 + C_{17}$, enough to maintain the V_{CC} in light- to no-load operations. In the application board, we have successfully tested a $4.7 \mu\text{F}$ value for C_3 and a $100 \mu\text{F}$ capacitor for C_{17} .

The start-up sequence also involves the internal 4 ms soft-start. During this time, the peak current setpoint is linearly increased from a very low value up to the allowable maximum. This soft-start circuitry is activated upon a fresh start-up but also every time a restart is attempted, e.g. in an auto-recovery fault mode.

Protections

There are several protections required by ac-dc adapters for the notebook market. They are listed below:

1. Short Circuit Protection, SCP: the adapter must sustain a permanent short-circuit on its output without being destroyed. When the fault has disappeared, the adapter must recover from the protection mode and deliver the rated power again. Auto-recovery OCP comes with NCP1256B (65 or 100 kHz). Some applications require a latched state when a short circuit is detected. In this case, extension “A” must be considered.
2. Over Voltage Protection, OVP: in case the loop is broken, e.g. the optocoupler is destroyed or the TL431 divider network is affected, the adapter must be immediately stopped and remain in that state until the user cycles the input power for reset. The OVP can be detected via the BO pin or simply through the V_{CC} pin in case runaway occurs.

- Over Temperature Protection, OTP: if the temperature of the adapter exceeds a certain ambient value, there is a risk of destruction. To avoid this from happening, a thermal sensor permanently monitors the temperature and in case it exceeds the limit set by the designer, the adapter shuts down permanently. Again, the adapter is reset when the user cycles the input power and the temperature has decreased.
- Over Power Protection, OPP: for some power supplies, it is important that the maximum output current stays in control in worse case conditions, e.g. when the load is drawing more current than what it should, without being a real short-circuit. In our design, the nominal output current is 3.2 A and must stay below 4.5 A in all input voltage conditions.

Let us now check how each requirement has been separately addressed.

Short-Circuit Protection

The protection is ensured by monitoring the current sense signal on pin 4. When this voltage exceeds the maximum internal current setpoint (0.8 V without OPP at low line or less when OPP is active), the internal 70 ms timer is started. The timer is reset if the current sense signal goes back below the maximum internal current setpoint for 8 consecutive clock times. This can happen if line ripple is superimposed on the FB signal, for instance at the lowest input level. If the timer completes its cycle, meaning the fault has been present longer than 70 ms without adverse reset, all driving pulses are immediately stopped and the part reduces its consumption to around 400 μ A. As V_{CC} decreases, it eventually touches the UVLO low level of 8.9 V where the part re-enters the start-up mode: consumption goes back to less than 10 μ A, V_{CC} rises up again and when reaching 18 V, the circuit pulses, attempting to re-start. A kind of auto-recovery burst mode takes place, ensuring a low average input power. There are two cases that we can think of:

- when the auxiliary and the power winding are well coupled, a short-circuit on the secondary side, very close to the board output, can potentially collapse the auxiliary winding on the primary side. This is the case during the start-up sequence for instance. As a result, the internal timer does not have time to reach completion and the pulses are interrupted by the UVLO level. This is what Figure 4 shows you. With the auto-recovery version, the part re-starts in a double hiccup. With the latched version, the pre-short capability makes the part latch off at the first power on sequence when UVLO is touched first.

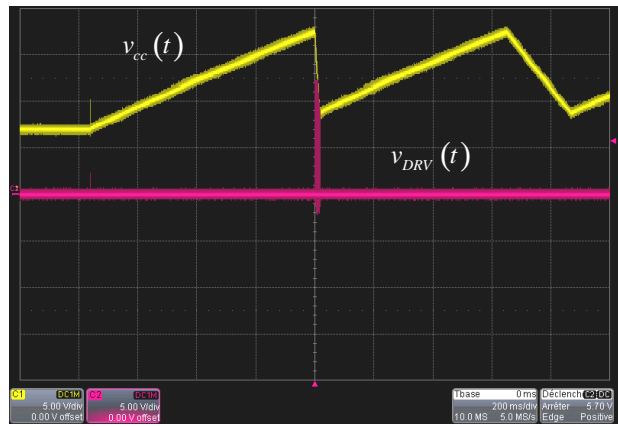

Figure 4. The Auxiliary Winding Collapses in Presence of a Short-Circuit at the Board Output: the Converter is well protected but the UVLO Trips First, not the Timer

- when a short-circuit is applied at the end of the cable, there are chances that the auxiliary voltage does not collapse, keeping the controller alive despite an over current on the secondary side. The timer can therefore count up to 70 ms (typical) and make the part enter auto-recovery as before however with a longer recurrence. This is what Figure 5 shows. Again, a low duty ratio in burst mode guarantees a low average input power ($0.07/1.94 = 3.6\%$).

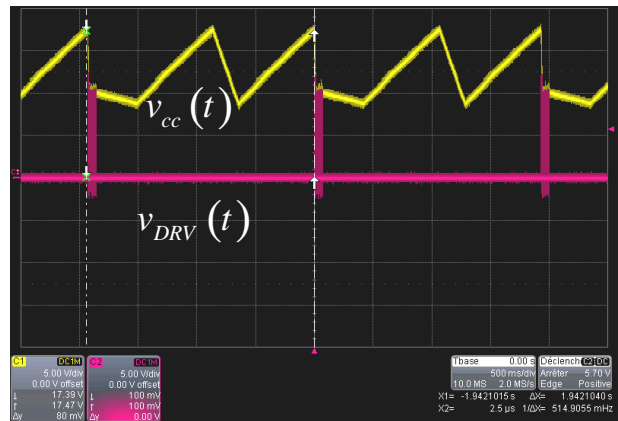

Figure 5. In this Case, the Timer Interrupts the Switching Pulses after 100 ms and the Part Enters Auto-recovery

Please note that the short circuit test can potentially latch off the controller as V_{CC} runs away. If the leakage inductance contribution is too strong, V_{CC} can significantly vary as I_{OUT} increases. To avoid the problem with this board, you can a) remove the OVP jumper b) try to calm down the leakage contribution by inserting a small resistor

in series with diode D_3 . A few ohms should be enough to maintain V_{CC} below the Zener voltage. Please also note that if V_{CC} approaches the Zener voltage – without tripping the BO latch – the voltage increase over R_7 will potentially disturb BO thresholds. As a conclusion, the Zener voltage must be selected so that V_{CC} is always below in worst case operation. The Zener shall be activated when the loop is broken only.

Over Voltage Protection

When the optocoupler is broken or when the TL431 divider network is affected by a severe drift (or one of its resistor is missing or features a wrong value), then the output voltage can escape from the limits imposed by the specifications: this is an over voltage condition. In the majority of cases, this condition is considered hazardous for the downstream load and the adapter must completely shut off. The NCP1256 deals with this problem via two possible options: a) the V_{CC} runs away and touches the upper limit of 26 V (typical) b) a dc voltage lifts the BO pin above 4.5 V and latches off the part. Both solutions are implemented in the demonstration board. In a latched state, V_{CC} hiccups up and down while all pulses are disabled. Reset occurs when V_{CC} drops below the V_{CC} reset value (8.65 V typical) or when the BO voltage is cycled (user unplugs the converter). However, BO cycling can only be detected while the IC operates. If BO resets while V_{CC} rises up, no reset is done. One way to accelerate the V_{CC} drop is to add a 1 M Ω resistor from V_{CC} to ground. This solution can only be considered if a) the standby power margin authorizes it b) enough start-up current exists.

We have captured several oscilloscope shots to illustrate the behavior of the circuit. Figure 7 displays the V_{CC} waveform obtained when the optocoupler LED is shorted in the secondary side at start up. The voltage increases and when it reaches 26 V, the part latches off.

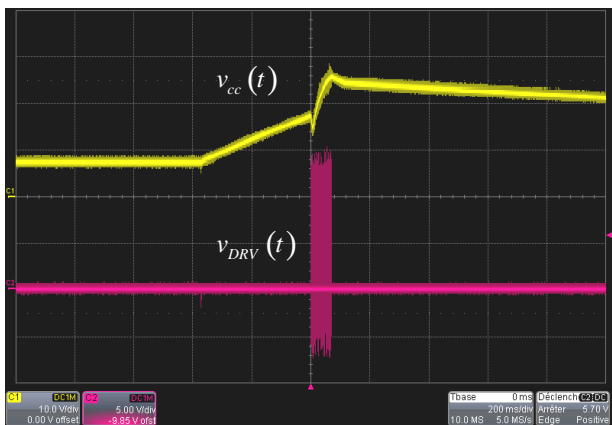

Figure 6. Here the V_{CC} Runs away at Start up and Activates the Controller Latch

In Figure 7, the optocoupler LED has been shorted and the converter runs open loop. V_{OUT} increases but the auxiliary V_{CC} also does until Zener diode D_7 conducts and lifts the BO pin for four successive clock cycles. The part latches off and remains locked until a BO reset or a V_{CC} cycling occurs.

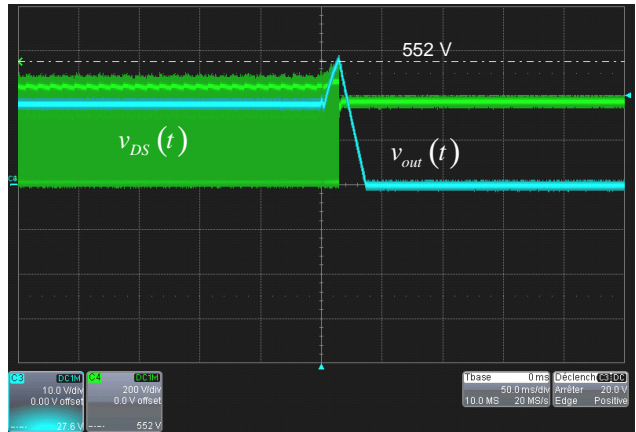

Figure 7. The Optocoupler LED has been Shorted in the Secondary Side and V_{out} Increases. This Information is Detected in the Primary Side and Latches off the Part via the BO Pin

Over Temperature Protection

OTP can be implemented by connecting a Negative Temperature Coefficient resistor (NTC) from the auxiliary winding to the current sense pin. This is what is shown in Figure 1 around R_{28} , R_{19} et D_2 . In this configuration, when the temperature increases, the NTC resistance starts decreasing and lifts up pin 3 voltage during the off time only (peak current and delivered power are not affected). When the level reaches 3 V, the part simply latches off and requires a reset before re-start. Reset occurs when the user cycles the input voltage.

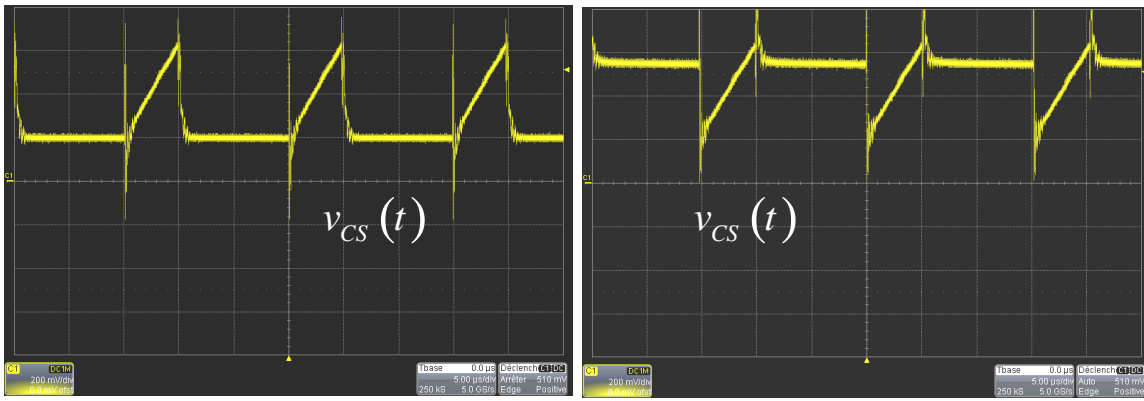

Figure 8. OTP is Implemented in a Simple and Efficient Way

We tested the demonstration board with the calculated setup and the test revealed a trip point around 103°C, close to what was expected.

Over Power Protection

A current-mode power supply works by setting the inductor peak current according to the output power demand. The inductor current is transformed into a voltage by a sense resistor, R_6 in our adapter. The peak current setpoint depends on the error voltage delivered on the feedback loop pin. In our adapter, this is the current forced by the TL431 on the secondary side and reflected to the primary over pin 2 of the NCP1256. As detailed in the

datasheet, the current setpoint inside the circuit depends on pin 2 level divided by 3. In fault conditions, when the loop is lost, the feedback level can go up to 4 V. To avoid any current runaway, the maximum voltage setpoint is safely clamped to 0.8 V. Reference [1] points to an article describing the over power phenomenon and how to limit the maximum power the converter can deliver. In the NCP1256, an offset is created on the CS pin and depends on the BO level. At the lowest line input, 85 V rms, the offset current is almost inexistent and full power is authorized. As the input voltage increases, the offset builds up in relationship to the series resistor R_{23} in Figure 1. The below data show the results obtained at different input voltages.

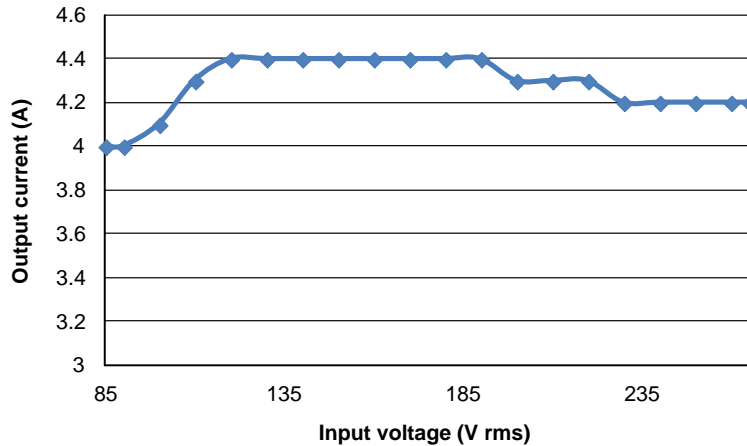

Figure 9. Maximum Delivered Output Current as a Function on the Input Line

The Secondary Side Feedback

The feedback is made around a classical TL431 network. We used the automated spreadsheet to evaluate the component values based on 1 kHz bandwidth target. A thorough description of the method is given in [2]. In an effort to further decrease the no-load standby power, we have implemented a proprietary technique around the NCP431. Despite its already low bias current, the data-sheet specifies a minimum current of 100 μ A. Usually, this minimum bias is ensured by paralleling a resistor with the optocoupler LED which exhibits a 1 V forward drop. If this extra current plays a positive role in the converter performance at high output levels, it is obviously detrimental to the standby power since it permanently draws several milliwatts in our 19 V example. The idea is to get rid of this bias in standby mode, without affecting the transient response in case the load is suddenly re-applied. Figure 10 shows you the proprietary idea we came up with. The principle is extremely simple: capacitor C_5 delivers a voltage equal to that of the output at full load, i.e. 19 V. These 19 V are used to bias the NCP431 via R_{19} . As the load is getting lighter, the controller enters the skip cycle mode. Given the time constant offered by C_5 together with the load made of R_{19} and the TL431 bias, the voltage across C_5 cannot be maintained: its average value collapses and the NCP431 bias disappears. In case the load is suddenly re-applied, the bias is automatically regenerated as the controller expands the duty ratio and the response is not affected. With a 19-V output, this technique helps saving several milliwatts seen from the primary side.

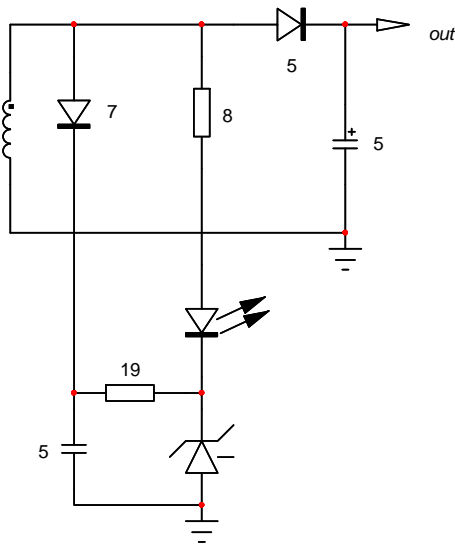

Figure 10. Simple Peak Rectifier Generates a Voltage Across C_5 whose Amplitude Falls down as the Controller Starts to Skip Cycle

Efficiency Performance

The NCP1256 excels in terms of efficiency and standby power. We have made a series of tests on the proposed adapter, carried at both high and low lines. The voltage is measured at the board output. The results appear below.

Table 1. EFFICIENCY PERFORMANCE

Output Power	Efficiency – $V_{in} = 110$ V rms (%)	Efficiency – $V_{in} = 230$ V rms (%)
15 W – 25%	89.4	88.8
30 W – 50%	89.5	89.7
45 W – 75%	89.7	89.7
60 W – 100%	89.2	90.1
Average efficiency	89.4	89.6

Table 2. NO-LOAD STANDBY POWER, LED IS OFF

Output Power	Input Power – $V_{in} = 100$ V rms (mW)	Input Power – $V_{in} = 230$ V rms (mW)
0	30	50

Table 3. NO-LOAD STANDBY POWER, LED IS ON

Output Power	Input Power – $V_{in} = 100$ V rms (mW)	Input Power – $V_{in} = 230$ V rms (mW)
0	42	60

Table 4. LIGHT LOAD EFFICIENCY

Output Power	Input Power – $V_{in} = 100$ V rms (W)	Input Power – $V_{in} = 230$ V rms (W)
0.5 W	0.66	0.67
0.6 W	0.79	0.80
0.7 W	0.90	0.92

The performance is linked to the combined action of the frequency foldback and the skip cycle operation at constant peak current. Please note that the no-load standby power includes the 4 M Ω discharge resistors string placed across the 0.22 μ F X2 capacitor on the input filter. These numbers are excellent considering a low-voltage controller featuring a start-up network.

Transient Response

The loop small-signal response has been measured and is the object of a dedicated application note. Please refer to [2] for more details. Loop stability is an important matter and must be seriously considered when working on high-volume projects. No trials and errors in the laboratory while observing the transient response, please! However, once the loop has been thoroughly reviewed and analyzed, some

transient tests can be performed to check that everything is ok. In our case, the output has been loaded by a current step from 0.1 A to 3.5 A with a slew-rate of 1 A/ μ s. Two input voltages have been considered, 100 V rms and 230 V rms. Such a wide loading step is a quite stringent test but as shown in Figure 11, the response at the board level stays within 2% of the nominal voltage of 19 V.

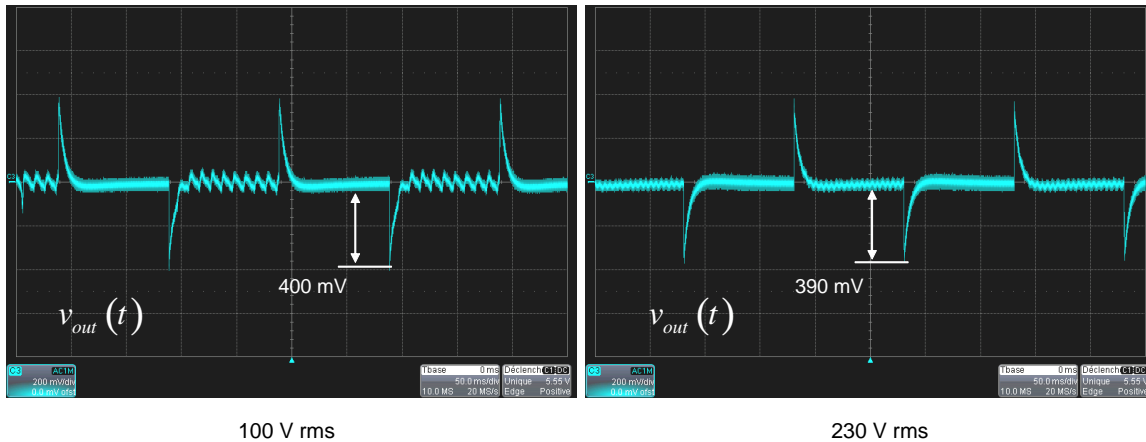

Figure 11. The Transient Response at Low Line and High Line are almost Identical and do not Show Signs of Instabilities

The ripple seen in the left side of the figure is due to the ripple on the bulk capacitor suddenly increasing when the load current is back.

Conclusion

This application note describes how an ac-dc converter meeting all new efficiency challenges can be built with the new NCP1256. Despite a small TSOP-6 package and a limited amount of pins, the performance of the final board nicely competes against other more complex circuits by offering a similar set of options plus protection features

simple to implement. This makes the part an ideal candidate where space constraints, performance and cost sensitivity are key considerations.

References

- [1] C. Basso, "Switch Mode Power Supplies: SPICE Simulations and Practical Designs", McGraw-Hill, 2012
- [2] AND8453, "Loop Control Design of an ac-dc Adapter Using the NCP1250", www.onsemi.com

ON Semiconductor and  are trademarks of Semiconductor Components Industries, LLC dba ON Semiconductor or its subsidiaries in the United States and/or other countries. ON Semiconductor owns the rights to a number of patents, trademarks, copyrights, trade secrets, and other intellectual property. A listing of ON Semiconductor's product/patent coverage may be accessed at www.onsemi.com/site/pdf/Patent-Marking.pdf. ON Semiconductor reserves the right to make changes without further notice to any products herein. ON Semiconductor makes no warranty, representation or guarantee regarding the suitability of its products for any particular purpose, nor does ON Semiconductor assume any liability arising out of the application or use of any product or circuit, and specifically disclaims any and all liability, including without limitation special, consequential or incidental damages. Buyer is responsible for its products and applications using ON Semiconductor products, including compliance with all laws, regulations and safety requirements or standards, regardless of any support or applications information provided by ON Semiconductor. "Typical" parameters which may be provided in ON Semiconductor data sheets and/or specifications can and do vary in different applications and actual performance may vary over time. All operating parameters, including "Typicals" must be validated for each customer application by customer's technical experts. ON Semiconductor does not convey any license under its patent rights nor the rights of others. ON Semiconductor products are not designed, intended, or authorized for use as a critical component in life support systems or any FDA Class 3 medical devices or medical devices with a same or similar classification in a foreign jurisdiction or any devices intended for implantation in the human body. Should Buyer purchase or use ON Semiconductor products for any such unintended or unauthorized application, Buyer shall indemnify and hold ON Semiconductor and its officers, employees, subsidiaries, affiliates, and distributors harmless against all claims, costs, damages, and expenses, and reasonable attorney fees arising out of, directly or indirectly, any claim of personal injury or death associated with such unintended or unauthorized use, even if such claim alleges that ON Semiconductor was negligent regarding the design or manufacture of the part. ON Semiconductor is an Equal Opportunity/Affirmative Action Employer. This literature is subject to all applicable copyright laws and is not for resale in any manner.

PUBLICATION ORDERING INFORMATION

LITERATURE FULFILLMENT:

Literature Distribution Center for ON Semiconductor
19521 E. 32nd Pkwy, Aurora, Colorado 80011 USA
Phone: 303-675-2175 or 800-344-3860 Toll Free USA/Canada
Fax: 303-675-2176 or 800-344-3867 Toll Free USA/Canada
Email: orderlit@onsemi.com

N. American Technical Support: 800-282-9855 Toll Free
USA/Canada
Europe, Middle East and Africa Technical Support:
Phone: 421 33 790 2910
Japan Customer Focus Center
Phone: 81-3-5817-1050

ON Semiconductor Website: www.onsemi.com

Order Literature: <http://www.onsemi.com/orderlit>

For additional information, please contact your local Sales Representative