



ON Semiconductor®

<http://onsemi.com>

Everything You Wanted to Know About Digital Potentiometer (POT)

Abstract

The digital POT is a mixed signal device. The analog portion of the device is the three-terminal analog component called potentiometer. The digital portion contains the interface, control, and registers associated with the potentiometer. The input signals to the digital section are the external control signals from the serial bus. The outputs of the digital section are internal signals stored in internal volatile and nonvolatile registers or signals which move the wiper. This application note answers frequently asked questions about the fundamentals of electronic or digital POTs.

QUESTION 1: Is there a functional difference between the mechanical and electronic potentiometers?

The function of the potentiometer section of the electronic potentiometer is the same as the mechanical version. In both cases, the potentiometer or pot is a three terminal device. Between two of the terminals is a resistive element. The third terminal called the wiper is connected to various points along this resistive element. The big difference between the two potentiometer technologies, Figure 1, is in the control section. In the mechanical version, the connection is physical or mechanical while in the electronic version the connection is electrical. The wiper of the mechanical potentiometer is physically moved by one's hand while the electronic version is digitally controlled, typically, by a computer or microcontroller. The most common terminal designations for the electronic potentiometer are R_L , R_H , and R_W .

QUESTION 2: How are electronic potentiometers controlled?

Most electronic potentiometers are controlled through a serial bus. There are, however, a few potentiometers designed to be controlled by control logic or front panel switches. The serial buses can be asynchronous or synchronous. The most common asynchronous bus is the increment/decrement interface. The most common synchronous buses are SPI, I²C, two wire, and microwire-like. The signals, Figure 2, perform clock, data in, data out, address, and control functions.

APPLICATION NOTE

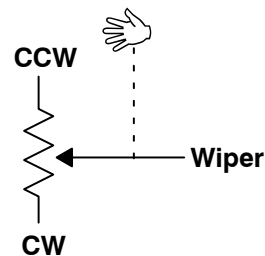

(A) Mechanical

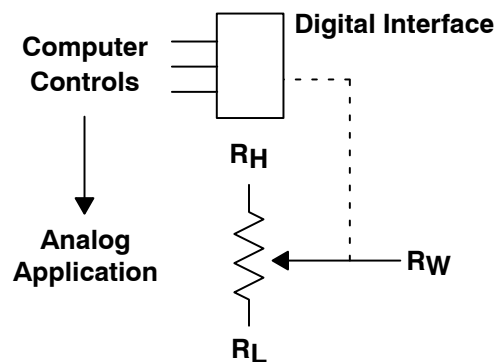

(B) Electronic

Figure 1. Potentiometers

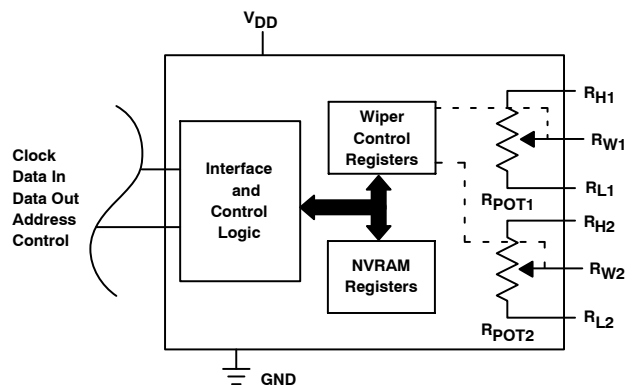

Figure 2. Control of Electronic Potentiometers

QUESTION 3: What functions do the digital controls of the different buses perform?

The signals for the asynchronous increment/decrement interface are \overline{CS} , U/\overline{D} , and \overline{INC} . The chip select signal \overline{CS} performs a chip enable function and is frequently used as an address input for multiple digital POT applications. The up/down signal U/\overline{D} sets the direction of the pot's wiper and is a level sensitive signal. The wiper movement occurs on the falling edge of the increment signal \overline{INC} .

The typical synchronous serial interface signals are (1) clock, called SCL or SCK, (2) a bidirectional data line SDA

or separate input/output data lines, SO and SI, (3) chip select /CS, and (4) one or more address lines, ADDR_x. The clock, data, and address signals along with a protocol move information in and out of the digital POT. All digital POTs contain one or more nonvolatile memory locations (NVRAM) where wiper settings can be stored under program control. All of the serial interfaces are industry standards whose specifics are covered in detail in technical references.

Figure 3 shows the asynchronous increment/decrement interface and the synchronous I²C interface.

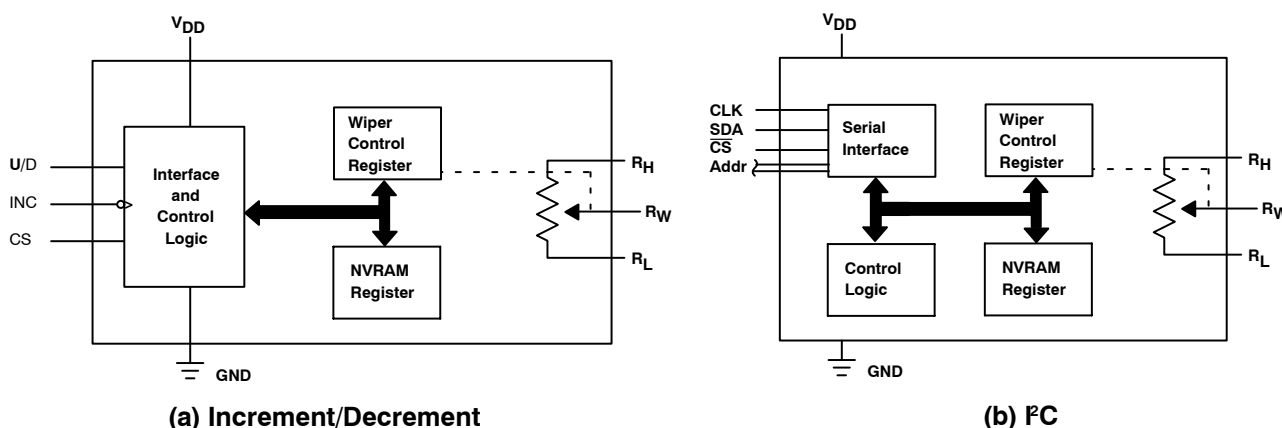

Figure 3. Serial Interfaces

QUESTION 4: How does the cost of the digital POT compare with the mechanical POT?

If one adds the purchase price to the cost of setting the mechanical pot in manufacturing and the field service costs due to the mechanical pot's reliability, the electronic version is significantly less expensive in its product's lifetime. In

general, the purchase price of the electronic potentiometer itself is in the \$0.40 to \$4 range depending on the number of pots in the package (single, dual, or quad), quantity ordered, and some of the pot's key parameters like resolution. Table 1 is a case study comparing two comparable mechanical and electronic potentiometers.

Table 1. COST COMPARISON – ELECTRONIC VERSUS MECHANICAL POTENTIOMETERS

	Electronic	Mechanical
Manufacturer:	ON Semiconductor	BC Components (Beyschlag Centralab)
Name:	ON Semiconductor	Model ST3, Cermet
Rpot:	10kΩ, Single	10kΩ, Single
Rpot Tolerance:	15%	20%
Resolution:	32 Taps	Single Turn, 210°
Package:	8L SOIC	3L Surface Mount
Purchase \$: (>100 Units)	\$0.75	\$1.35
Assembly \$: (Automated)	\$0.04 – .08	\$0.04 – .08
Pot Adjustment \$: (ATE)	<<\$0.01	\$0.12 + 0.20
Rational Life:	Infinite	200 Cycles
Reliability:	< 100FITs	??
Field Service \$:	\$	\$\$\$

NOTE: The assembly and test costs (California) were obtained from a leading contract manufacturer. Costs include overhead. The adjustment costs for mechanical pots have two parts: ATE costs and labor costs. Purchase prices are from known publications (2001). The examples of pots were chosen for similarity in basic performance and in package type.

QUESTION 5: In what type of applications can the digital POT be used?

The digital POT is a candidate in any application in which a variable or a parameter has to be regulated, adjusted, or controlled. Digital POTs control voltage, current, resistance, power, inductance, capacitance, frequency, bandwidth, time, gain, duty cycle, Q, etc. Any circuit which has a resistance (how many analog circuits do NOT have a resistance?) is a candidate for a digital POT application. The analog potentiometer is used in analog circuits, Figure 4, to vary and control the parameters of analog functions. Most electronic potentiometers are designed for 5 V or ± 5 V systems. Today, most electronic products are mixed signal systems. Thus, the mixed signal digital POT is compatible with these systems.

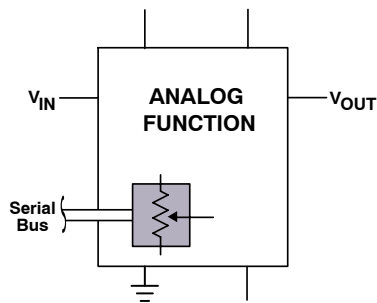
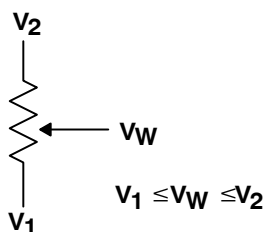

Figure 4. Programmable Analog Circuit

QUESTION 6: What are the basic ways of using a digital POT?

The electronic potentiometer is a three terminal device and has two fundamental modes or configurations; (1) three terminals and (2) two terminals. As a three terminal device, the pot is a resistive divider and as a two terminal device

(called the rheostat mode) the pot is a variable resistance. Figure 5 illustrates the two basic modes and basic applications.



Programmable Voltage

(a) Three Terminal, Divider Mode

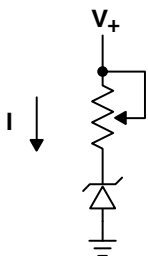

Programmable Current

(b) Two Terminal, Rheostat Mode

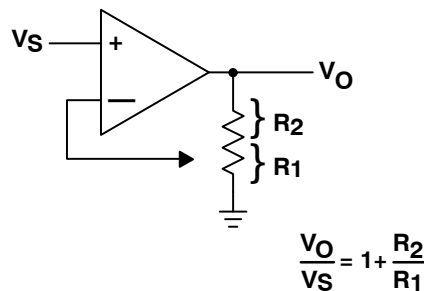

Programmable Gain

$$\frac{V_O}{V_S} = 1 + \frac{R_2}{R_1}$$

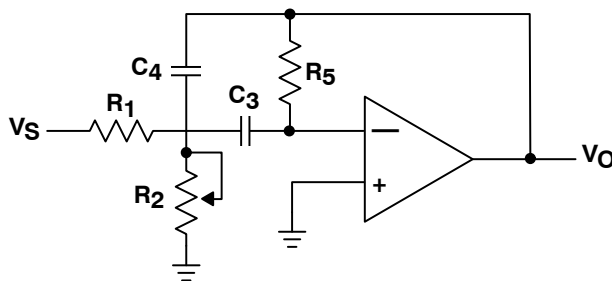

Programmable Bandwidth

Figure 5. Basic Potentiometer Applications

QUESTION 7: How do I mathematically analyze an analog circuit that has a potentiometer?

The broadest way to look at the potentiometer is as a two-resistor, three-node device where the two resistors can be changed in value so long as their sum is constant or is equal to the end-to-end resistance of the pot called R_{POT} . This idea is illustrated in Figure 6, including the mathematical model of the pot's resistances. The wiper

'position factor 'p' is a dimensionless number that varies from 0 to 1 and represents the proportionate position of the wiper as it goes from one end of the potentiometer to the other. The p factor will show up in the defining equations for the circuit, and it represents another degree of freedom for the design engineer. The engineer can evaluate the effect of the variability of the potentiometer on a circuit parameter by varying p from zero to one.

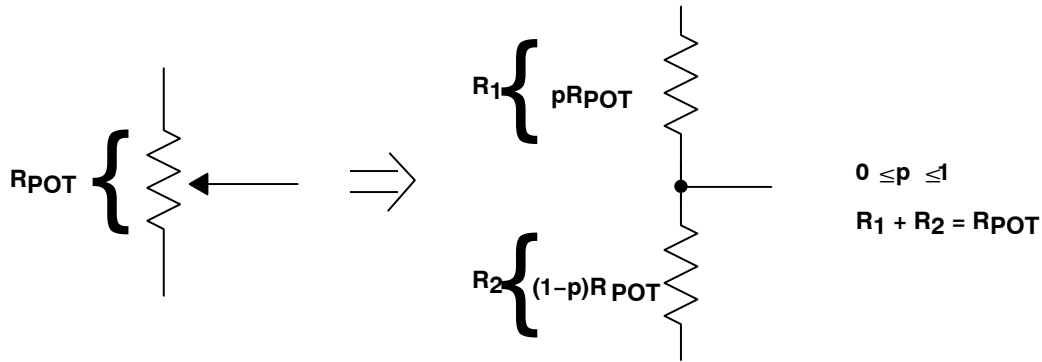
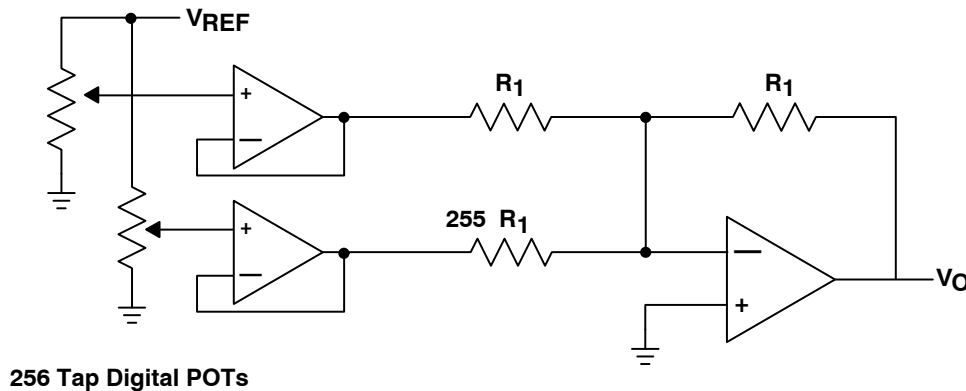

Figure 6. Mathematical Model of the Pot Resistances

QUESTION 8: High resolution is important in many applications. Are there high resolution electronic potentiometers?

Yes. The resolution of ON Semiconductor's potentiometers is related to the number of taps which vary

from 32 to 256. However, there are a number of low cost circuit solutions which will extend the resolution to an unlimited number. The circuit in Figure 7 provides 16 bits of resolution and is but one way, of many, of extending the basic resolution of the digital POT's application.



256 Tap Digital POTs

Figure 7. High Resolution Summer Circuit

QUESTION 9: Do I have to have a computer or processor in my application circuit? Do I have to have a computer and the services of a software engineer to control the digital POT in my engineering prototype circuit?

The asynchronous, increment/decrement serial interface is simple enough that it can be controlled in application circuits by (1) a processor or (2) discrete logic or (3) front panel switches. Application and design notes show how these methods of control can be implemented. Tools are available for the analog designer to program the digital POT in his prototype circuit in the form of evaluation or test

boards. Some test boards, depending on the interface, are switch programmed and others are computer controlled through a graphical user interface.

QUESTION 10: Why would an analog design engineer use a digital POT instead of a mechanical POT?

Except in cases of very high power, current, and voltage, the electronic potentiometer is superior because it is (1) digitally controlled, (2) programmable, (3) cost effective in manufacturing (4) more reliable, (5) fast, (6) compatible with standard automated assembly techniques, (7) smaller size, and (8) lower weight.

QUESTION 11: Can I replace the mechanical pots in my current product with electronic potentiometers?

In general, no or at best it is very difficult. The mechanical potentiometer is a three-terminal physical device while the electronic pot is at minimum an eight-terminal integrated circuit. Besides the package differences, circuits designed with mechanical pots do not have provisions for control signals.

QUESTION 12: Where does the wiper of the electronic potentiometer go when power is turned-on?

When V_{CC} is applied, the power on recall (POR) circuit in the digital POT retrieves the last stored wiper position value from nonvolatile memory.

QUESTION 13: Is not the digital POT another way of implementing a digital-to-analog convertor (DAC)?

It is true the digital POT is often used as a digital-to-analog voltage converter or programmable voltage divider. In fact, many engineers will use the digital POT as a DAC substitute because of the nonvolatility feature of the pot. However, using a digital POT for a DAC represents but one application of tens of thousands.

QUESTION 14: What is the maximum operating frequency of the digital POT?

The frequency limiting factor of the digital POT is the wiper (to ground) capacitance, C_W , which is about 20 pF. The effect of C_W depends on where it is in an application circuit. For applications where the potentiometer is used as a passive attenuator (like a volume control circuit), the nominal upper cutoff frequency of a 10 k Ω potentiometer is 1.7 MHz. The cutoff frequency is directly proportional to R_{POT} and is therefore proportionally lower for 100 k Ω devices and higher for 1 k Ω versions.

QUESTION 15: What are the key parameters to consider when designing with digital POTs?

The technical parameters of digital POTs are (1) end-to-end resistance called R_{POT} and its accuracy, (2) the voltage limitations of the pot pins, V_{RX} , (3) linearity, integral and differential, (4) wiper resistance and wiper current, R_{WI} and I_W , (5) temperature coefficients, TC_{RPOT} and TC_{RATIO} , (6) isolation resistance, R_{ISO} , (7) noise, and (8) potentiometer capacitances, C_H , C_L , and C_W .

The most common values of the end-to-end resistance of the potentiometer are 10 k Ω , 100 k Ω , and 1 k Ω . Although the number of values of R_{POT} are limited, there are circuit techniques allowing the designer to customize the value of the pot to his application. The accuracy of R_{POT} is either 15% or 20%. The matching of R_{POT} values in multiple pot packages is much better, in the 1% range. The majority of the electronic potentiometers are designed for +5 V or ± 5 V systems. The linearity specifications of the digital POT are similar to a DAC, one-half to one LSB. The wiper resistance (nominally 400 Ω) and wiper current (1 mA) specs are important when using the pot as a two-terminal device. Again, there are circuit techniques circumventing these limitations. Two TC specs specify the performance of the digital POT with temperature. TC_{RPOT} describes the variation of the end-to-end resistance of the pot with temperature while TC_{RATIO} describes the ratiometric behavior of the resistor divider with temperature.

Of course, the non-technical parameters of price, delivery, package type, etc are also important.

For further technical help, please contact the applications department at ON Semiconductor.

ON Semiconductor and  are registered trademarks of Semiconductor Components Industries, LLC (SCILLC). SCILLC owns the rights to a number of patents, trademarks, copyrights, trade secrets, and other intellectual property. A listing of SCILLC's product/patent coverage may be accessed at www.onsemi.com/site/pdf/Patent-Marking.pdf. SCILLC reserves the right to make changes without further notice to any products herein. SCILLC makes no warranty, representation or guarantee regarding the suitability of its products for any particular purpose, nor does SCILLC assume any liability arising out of the application or use of any product or circuit, and specifically disclaims any and all liability, including without limitation special, consequential or incidental damages. "Typical" parameters which may be provided in SCILLC data sheets and/or specifications can and do vary in different applications and actual performance may vary over time. All operating parameters, including "Typicals" must be validated for each customer application by customer's technical experts. SCILLC does not convey any license under its patent rights nor the rights of others. SCILLC products are not designed, intended, or authorized for use as components in systems intended for surgical implant into the body, or other applications intended to support or sustain life, or for any other application in which the failure of the SCILLC product could create a situation where personal injury or death may occur. Should Buyer purchase or use SCILLC products for any such unintended or unauthorized application, Buyer shall indemnify and hold SCILLC and its officers, employees, subsidiaries, affiliates, and distributors harmless against all claims, costs, damages, and expenses, and reasonable attorney fees arising out of, directly or indirectly, any claim of personal injury or death associated with such unintended or unauthorized use, even if such claim alleges that SCILLC was negligent regarding the design or manufacture of the part. SCILLC is an Equal Opportunity/Affirmative Action Employer. This literature is subject to all applicable copyright laws and is not for resale in any manner.

PUBLICATION ORDERING INFORMATION**LITERATURE FULFILLMENT:**

Literature Distribution Center for ON Semiconductor
P.O. Box 5163, Denver, Colorado 80217 USA
Phone: 303-675-2175 or 800-344-3860 Toll Free USA/Canada
Fax: 303-675-2176 or 800-344-3867 Toll Free USA/Canada
Email: orderlit@onsemi.com

N. American Technical Support: 800-282-9855 Toll Free
USA/Canada
Europe, Middle East and Africa Technical Support:
Phone: 421 33 790 2910
Japan Customer Focus Center
Phone: 81-3-5817-1050

ON Semiconductor Website: www.onsemi.com

Order Literature: <http://www.onsemi.com/orderlit>

For additional information, please contact your local Sales Representative