



## 700 mA LED Power Supply Using Monolithic Controller and Off-Line Current Boosted (Tapped Inductor) Buck Converter

Prepared by: Frank Cathell  
ON Semiconductor

### Introduction

Light emitting diodes (LEDs) are rapidly proliferating into commercial and domestic lighting applications because of their high efficiency as light sources. Unlike a conventional incandescent filament type of lamp which appears as essentially a pure resistance and prefers a stable voltage source, the LED requires a special type of power source in which the current is regulated over input line changes and for tolerance variations in the LED's forward voltage drop. The device current must remain constant despite the voltage that may appear across the total LED string. The available power source voltage, however, must be slightly greater than the worst case total forward voltage drop of the string of LEDs. In applications where user safety is not an issue, and the LEDs are isolated in some type of protective enclosure, the simple off-line buck switching converter is an ideal power source for the LEDs. A typical 325 mA off-line buck converter using ON Semiconductor's NCP1014 integrated MOSFET -PWM controller is shown

in Figure 1. This conventional buck converter uses a current setting resistor on U1's feedback pin to set the output current without using a closed loop feedback. This is possible because the controller uses current mode control and the output current through the LED load is a close approximation of the fixed peak current in the MOSFET which is set by resistor R2. This scheme is very simple and provides acceptable line regulation over a typical AC input range due to the inherent feed forward action of current mode control to line variations. This open loop scheme is not acceptable for universal AC input using a single resistor value, however, and will require a different R2 value for 90 Vac to 135 Vac and 190 Vac to 265 Vac. Additional trimming of the current setting resistor R2 may be required for different series LED configurations and the resultant Vf variation of the output voltage caused by the LED forward drops. Once set for the specific application, this simple buck circuit will generally provide an adequate LED driver.

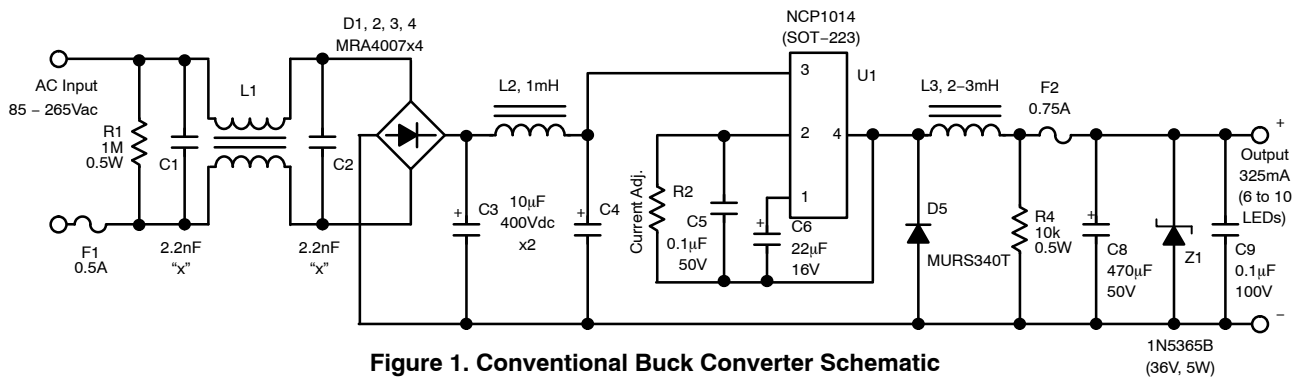

Figure 1. Conventional Buck Converter Schematic

There are limitations to the simple buck converter, however, depending on the required AC input voltage range, the number of series LEDs to be driven, and the output current requirement. Listed below are some of the limitations and facts that, despite its simplicity, are frequently overlooked when utilizing a buck converter.

1. The total  $V_f$  or forward voltage drop of the LEDs must be less than the minimum dc voltage presented to the input of the buck switching stage times the maximum available duty cycle  $D$  of the buck controller (buck output voltage is merely the integral of its output switching waveform). For a minimum input of 85 Vac for example, the available dc voltage would be about 120 Vdc, so the total  $V_f$  of the LED string should not be more than 120 V times  $0.67 = 80$  V; the latter decimal number being the maximum duty cycle  $D$  of the NCP1014 controller. To allow for tolerances due to  $D$ , AC input ripple, and typical circuit inefficiencies, a maximum  $V_f$  of 70 V would be more conservative.
2. In most LED applications the reverse scenario is usually the case where only a few LEDs are required and the differential between the buck dc input and required LED maximum output voltage is large, especially when the input is nominally 240 Vac. For an application requiring say, 4 LEDs each with a  $V_f$  of 4 V max, the output voltage requirement is 16 V. This translates to a 10:1 voltage reduction for a nominal 120 Vac input ( $V_{dc} = 1.4 \times 120 \text{ Vac} = 168 \text{ Vdc}$ ) and double this for 240 Vac. This conversion ratio will have an efficiency impact on the buck converter due to the very small PWM duty cycle necessary to get this low of a voltage. Assuming a switching frequency of 100 kHz, this would translate to a pulse width of 1  $\mu\text{s}$ . If we were to only want to drive 2 LEDs, this would be reduced to 0.5  $\mu\text{s}$  which would further impact the conversion efficiency.
3. The peak current through the inductor, the freewheel diode, and switching MOSFET in the conventional buck is simply the magnitude of the dc load current plus the magnetizing ramp of the buck inductor. As the inductance of the choke increases, the magnetizing current ramp

diminishes, so the design tradeoff is between allowable peak current and choke size. It is obviously preferable to operate the buck in this continuous conduction mode (CCM) because the peak current through the MOSFET is minimized with resultant greater conversion efficiency.

4. In the conventional buck configuration the dc output current must necessarily be less than the maximum rated MOSFET current or, in the case of the NCP1014, the peak current as set by the internal current limit circuit. For the NCP1014 the current limit is slightly more than 400 mA worst case, so the maximum output current for a buck using this device will be around 350 mA assuming that the inductor magnetizing current is 50 mA or less.
5. Unfortunately, this latter current constraint in combination with the very short duty cycle mentioned in (2) above severely limits the conversion efficiency of the conventional off-line buck for applications that drive a small number of LEDs. We shall now see a way of modifying the buck inductor to overcome this limitation and even get 700 mA (or more) of output current for small LED strings that require this output current level.

#### The Tapped Inductor Buck

Figure 2 shows the complete off-line, NCP1014 based buck converter for developing 700 mA for strings of approximately 6 or less LEDs. This circuit is a “bare bones” implementation in which the current level is again set by resistor R2 on the feedback pin of the 1014. Since the controller utilizes current mode control, and since CCM buck converters have inherent load regulation (idealized case!), the output current can be made essentially constant, as mentioned previously, by merely fixing the peak current in the MOSFET, and hence the peak current in the buck inductor winding (L3). A plot of the line regulation for 90 Vac to 140 Vac input is shown in Figure 3. The overall regulation is maintained to about  $\pm 5\%$  from 700 mA nominal. The circuit is intended for applications where the LEDs are always connected, otherwise, an output overvoltage condition will occur if the output is opened circuited. Zener Z1 and fuse F1 provides a failsafe OV protection scheme in the event a no-load situation occurs.

# AND8328/D

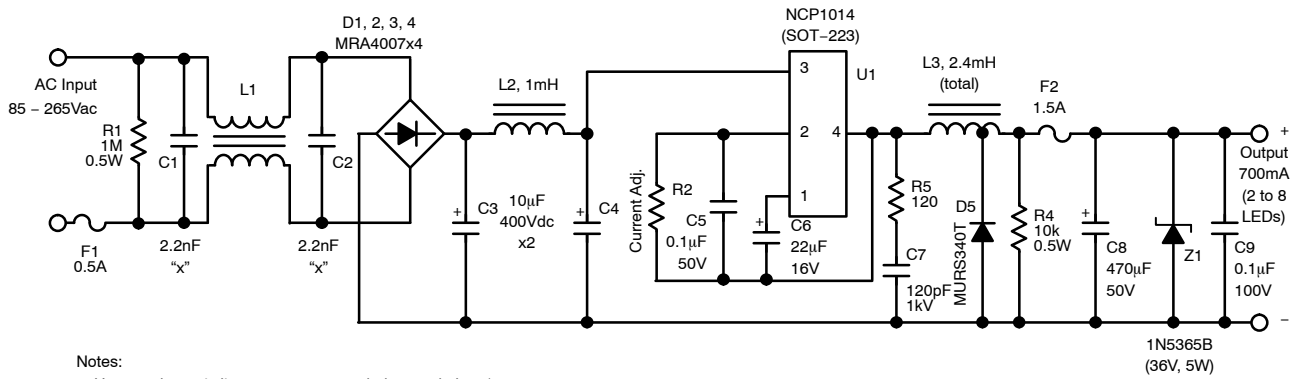

**Notes:**

1. Heavy schematic lines are recommended ground plane/copper pour areas.
2. Crossed schematic lines are not connected.
3. L1 is Coilcraft E3491-AL EMI inductor or equivalent (3.9 mH, 700 mA)
4. L2 is Coilcraft RFB1010-102L or equivalent (1.0 mH, 600 mA).
5. See L3 drawing for design details.
6. U1 tab (pin 4) should have copper clad ground plane as heatsink.
7. Zener Z1 and fuse F2 are for OV protection in the event of an open LED string.
8. R2 sets output current for selected input voltage range.
9. For optional closed loop sensing circuit to right; R5 sets output current by approximately  $I_{out} = 0.65/R5$  and Z2 clamps  $V_{out}$  max to zener voltage.

**Optional Output Section with Constant Current Output and Active Voltage Clamp Using Closed Loop Optocoupler Feedback**

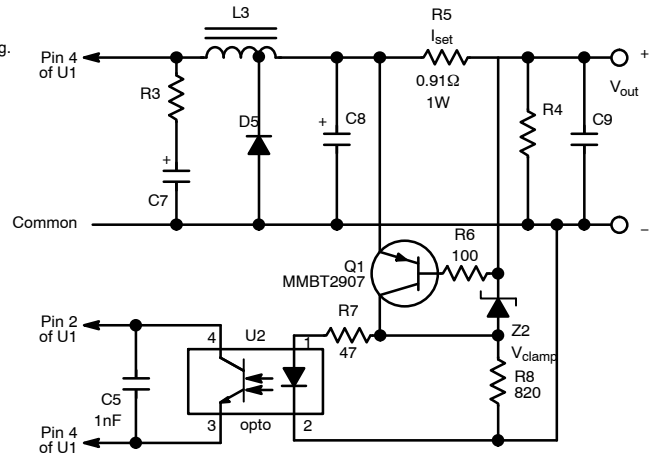

**Figure 2. Tapped Inductor (Current Boosted) Buck Converter**

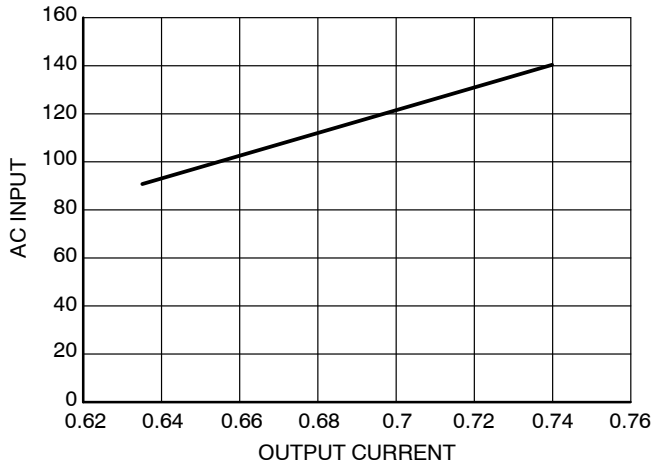

Figure 3. Line Regulation of Simple Tapped Inductor Buck

For applications requiring tighter current regulation and active output voltage limiting, the lower right schematic of Figure 2 shows an inexpensive and simple optocoupler feedback scheme providing both parameters means of closed loop control. This closed loop sensing scheme is necessary for universal input applications (85 Vac to 265 Vac) where a single, fixed resistor on the feedback pin of U2 is not adequate for reasonable current control over this wide of an input range. The optocoupler in the feedback path is necessary due to the fact that U1 is ground referenced to the switching node at the input to the inductor L3. The output current and  $V_{out}$  clamp level is set by R5 and Z2 respectively.

The output current boosting effect is accomplished by tapping the buck inductor 3/4 the way down the choke winding such that a turns ratio of 3:1 is achieved. For high buck dc input to output ratios such as this application (typically 10:1 or higher), the 3:1 tapped inductor scheme can theoretically provide close to 3 times the output current that would normally be available from the controller. The operation of the tapped inductor buck and the associated equations are presented in detail in ON Semiconductor application note AND8318. When reading this application note one should pay close attention to the choke winding details and the necessity for close coupling between the choke winding sections.

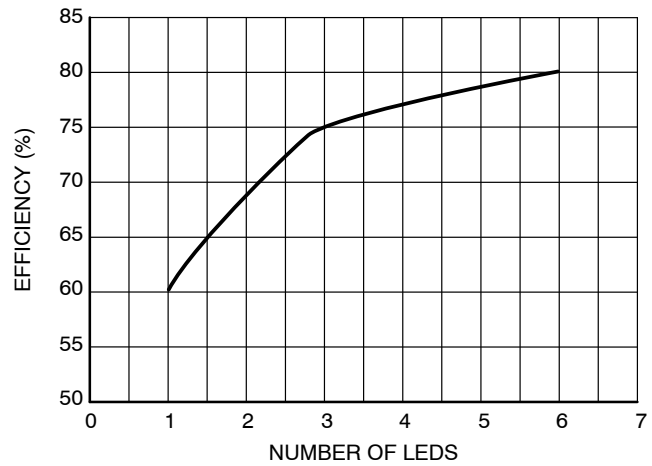

Figure 4. Efficiency versus Number of Series LEDs (120 Vac Input)

Since nothing is obtained for free, the current boosting effect of the inductor causes the duty cycle of the controller to increase proportional to the amount the current is boosted. This would be expected since the output current is just the integral of the current waveshape presented to the input to the inductor. Extracting more output current by expanding the converter duty cycle via the tapped inductor increases the conversion efficiency. The tapped inductor approach, as mentioned in AND8318, begins to have diminishing returns as the buck output voltage approaches the “raw” dc input. For ratios of 4:1 or less, the conventional non-tapped inductor buck is a better choice (Figure 1). However, there are cases where some improvement in efficiency can be had where the input to output dc ratio is slightly higher than 4:1. In such cases a 1:1 inductor turns ratio would probably be optimal. The inductor would be tapped exactly in the center of the winding in this case. Again, the technical descriptions in AND8318 cover this.

The graph in Figure 4 shows the effect that the number of output LEDs has on the converter’s efficiency. As expected, the efficiency drops significantly with fewer LEDs due to the high dc conversion ratio. As the number of LEDs approaches the optimum  $V_f$  or  $V_{out}$  level for the tapped inductor, the efficiency easily makes the 80% level.

## AND8328/D

Figure 5 shows the current through the NCP1014 MOSFET (blue) and the voltage across the device (yellow) during several switching periods for a 700 mA load current. Note that the peak current is just slightly over 300 mA which is well within the device's maximum current limit trip level ( $> 400$  mA).

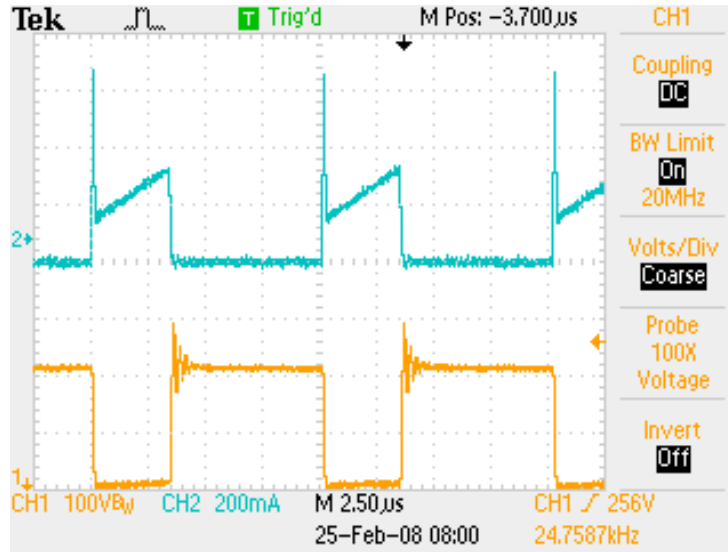

Figure 5. NCP1014 (U1) MOSFET Drain current and voltage (120 Vac, 5 LEDs in series)

Figure 6 shows the current in the freewheel part of the tapped inductor (L3) winding (blue). Note the large current step at the point of MOSFET turn-off and the ringing caused by the inter-winding leakage inductance. The current step occurs because the ampere-turn relationship for the inductor must be maintained when the switch turns off and the current now is directed through 1/4 of the total inductor winding. The peak current increases to 1.2 A or 4 times that of the peak MOSFET on-state current from the previous figure. The dc output current, of course, is the weighted average level of the current in the inductor.

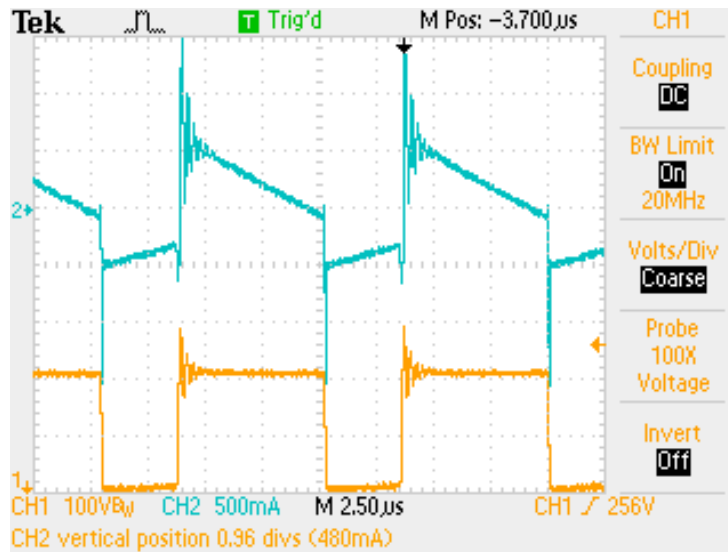

Figure 6. Current through L3 inductor freewheel winding section (and Drain voltage for reference)

## AND8328/D

Figure 7 shows the 50 mA peak-to-peak output current ripple in the LEDs (blue) and the filtering effect that output capacitor C8 has on the inductor waveform. The voltage across the NCP1014 MOSFET is also shown in yellow for reference.

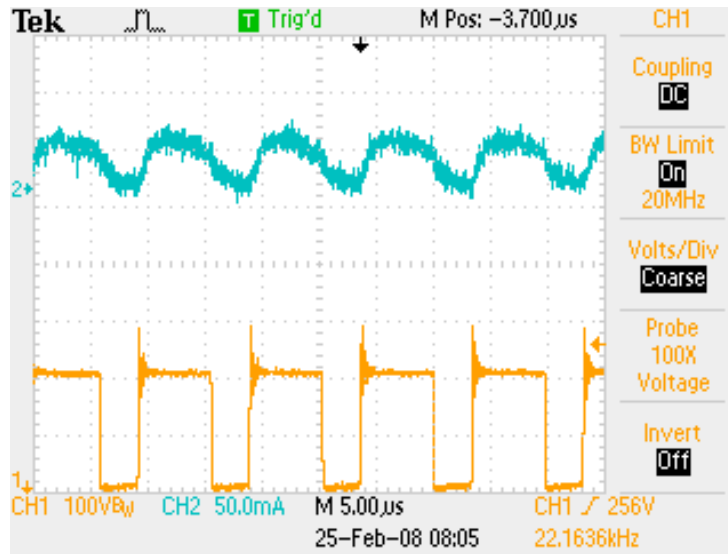

Figure 7. LED Ripple Current (and MOSFET Drain Voltage for Reference)

**AND8328/D**

Figure 8 is the tapped inductor magnetic design sheet and gives the winding details of the buck choke L3 of the schematic in Figure 2.

**MAGNETICS DESIGN DATA SHEET**

Project / Customer: 700 mA LED Driver

Part Description: 1 A Tapped Buck Inductor – LED Driver (Rev 1)

Schematic ID: L3

Core Type: E24/25 (E25/10/6); 3C90 material or similar

Core Gap: Gap for 140 to 160 uH measured across any one winding

Inductance: 150 uH nominal across any winding

Bobbin Type: 10 pin horizontal mount for E24/25 (E25/10/6)

Windings (in order):

Winding # / type	Turns / Material / Gauge / Insulation Data
Main Winding (quadra-filar) (2,3,4,5 – 9,8,7,6)	4 turns quadrafilar (4 wires in hand) of #24HN per layer X 8 layers (32 turns per wire over 8 layers. Self-leads to pins.

Hipot: 300 V between individual windings.

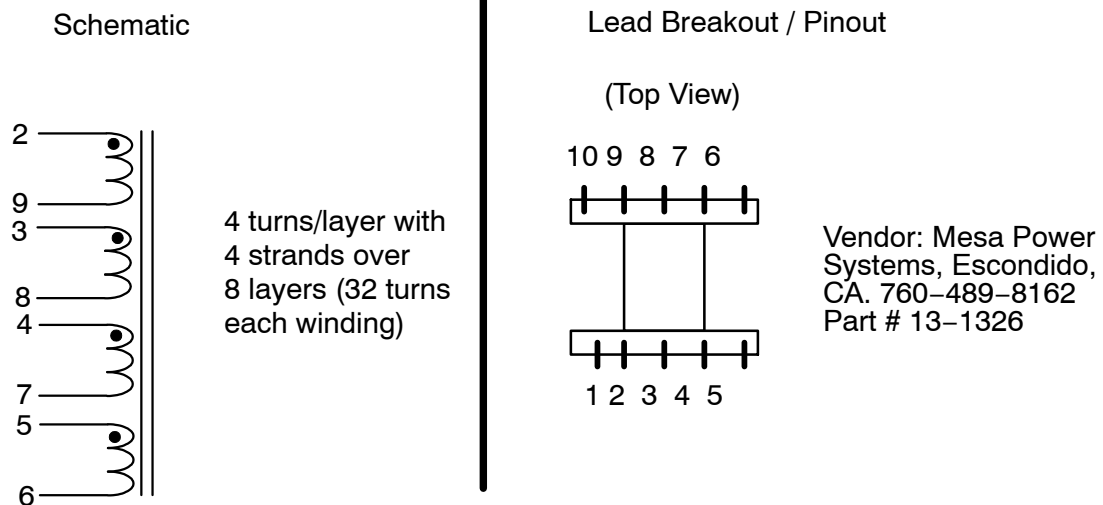

**Figure 8. Tapped Inductor L3 Design Details**

## Additional Comments

1. Referring to the schematics of Figure 2, it should be noted that the power supply design includes input common mode (L1) and differential mode (C1, C2, L2) filters for conducted EMI attenuation. Depending on the application and power supply layout and packaging, L2 may not be necessary.
2. The R/C snubber network of R3 and C7 is optional but recommended because of the leakage inductance between the windings in L3. The uncoupled flux between the first and last sections of the windings will create a voltage spike on the NCP1014's internal MOSFET's source/drain that could be destructive. As indicated in the magnetics design of Figure 8, the choke should be quadrifilar wound and the appropriate windings connected in series-aiding with the last winding (1/4 of total) comprising the freewheel diode winding. This winding technique will minimize the leakage inductance effects. Depending on the characteristics of the choke's windings, it may be necessary to "tweak" the values of R3 and C7 for optimization.
3. The value of R2 will be in the range of several 10s of k $\Omega$  if the simple non-closed loop scheme is used. In the particular test breadboard of the circuit the value of the resistor was 27k for four, 700 mA LEDs in series ( $V_f = 13$  Vdc) and 120 Vac input.

4. There are other schemes to implement closed loop current sensing for the circuit (see ON Semiconductor Design Note DN06037), however, the optocoupler feedback scheme of Figure 2 is the most accurate for a simple circuit. It should also be noted that the "bootstrap" output voltage sensing scheme of DN06037 is totally incompatible with the tapped inductor buck illustrated here. That particular voltage sense scheme depends on the Pin 4 switched node of U1 being brought to a virtual ground level during part of the switching cycle so that the bootstrap mechanism can function. This cannot happen on the tapped inductor implementation due to the location of the freewheel diode D5. For a conventional buck with D5's cathode connected to pin 4 of U1, the bootstrap voltage sense scheme will work OK.

## References

1. ON Semiconductor Data Sheet for NCP1010 to NCP1014 series of monolithic switchers.
2. ON Semiconductor Application Note AND8318
3. ON Semiconductor Design Notes DN06037, DN06011, DN06009, DN06027, DN06002, and DN06018
4. Modern DC-to-DC Switchmode Power Converter Circuits, Chapter 8, by Rudy Severns and Gordon Bloom, (Van Nostrand Reinhold, 1985)

ON Semiconductor and  are registered trademarks of Semiconductor Components Industries, LLC (SCILLC). SCILLC reserves the right to make changes without further notice to any products herein. SCILLC makes no warranty, representation or guarantee regarding the suitability of its products for any particular purpose, nor does SCILLC assume any liability arising out of the application or use of any product or circuit, and specifically disclaims any and all liability, including without limitation special, consequential or incidental damages. "Typical" parameters which may be provided in SCILLC data sheets and/or specifications can and do vary in different applications and actual performance may vary over time. All operating parameters, including "Typicals" must be validated for each customer application by customer's technical experts. SCILLC does not convey any license under its patent rights nor the rights of others. SCILLC products are not designed, intended, or authorized for use as components in systems intended for surgical implant into the body, or other applications intended to support or sustain life, or for any other application in which the failure of the SCILLC product could create a situation where personal injury or death may occur. Should Buyer purchase or use SCILLC products for any such unintended or unauthorized application, Buyer shall indemnify and hold SCILLC and its officers, employees, subsidiaries, affiliates, and distributors harmless against all claims, costs, damages, and expenses, and reasonable attorney fees arising out of, directly or indirectly, any claim of personal injury or death associated with such unintended or unauthorized use, even if such claim alleges that SCILLC was negligent regarding the design or manufacture of the part. SCILLC is an Equal Opportunity/Affirmative Action Employer. This literature is subject to all applicable copyright laws and is not for resale in any manner.

## PUBLICATION ORDERING INFORMATION

### LITERATURE FULFILLMENT:

Literature Distribution Center for ON Semiconductor  
P.O. Box 5163, Denver, Colorado 80217 USA  
**Phone:** 303-675-2175 or 800-344-3860 Toll Free USA/Canada  
**Fax:** 303-675-2176 or 800-344-3867 Toll Free USA/Canada  
**Email:** orderlit@onsemi.com

**N. American Technical Support:** 800-282-9855 Toll Free  
USA/Canada  
**Europe, Middle East and Africa Technical Support:**  
Phone: 421 33 790 2910  
**Japan Customer Focus Center**  
Phone: 81-3-5773-3850

**ON Semiconductor Website:** [www.onsemi.com](http://www.onsemi.com)

**Order Literature:** <http://www.onsemi.com/orderlit>

For additional information, please contact your local Sales Representative