

ON Semiconductor

Is Now

onsemi™

To learn more about onsemi™, please visit our website at
www.onsemi.com

onsemi and **onsemi** and other names, marks, and brands are registered and/or common law trademarks of Semiconductor Components Industries, LLC dba "**onsemi**" or its affiliates and/or subsidiaries in the United States and/or other countries. **onsemi** owns the rights to a number of patents, trademarks, copyrights, trade secrets, and other intellectual property. A listing of **onsemi** product/patent coverage may be accessed at www.onsemi.com/site/pdf/Patent-Marking.pdf. **onsemi** reserves the right to make changes at any time to any products or information herein, without notice. The information herein is provided "as-is" and **onsemi** makes no warranty, representation or guarantee regarding the accuracy of the information, product features, availability, functionality, or suitability of its products for any particular purpose, nor does **onsemi** assume any liability arising out of the application or use of any product or circuit, and specifically disclaims any and all liability, including without limitation special, consequential or incidental damages. Buyer is responsible for its products and applications using **onsemi** products, including compliance with all laws, regulations and safety requirements or standards, regardless of any support or applications information provided by **onsemi**. "Typical" parameters which may be provided in **onsemi** data sheets and/or specifications can and do vary in different applications and actual performance may vary over time. All operating parameters, including "Typicals" must be validated for each customer application by customer's technical experts. **onsemi** does not convey any license under any of its intellectual property rights nor the rights of others. **onsemi** products are not designed, intended, or authorized for use as a critical component in life support systems or any FDA Class 3 medical devices or medical devices with a same or similar classification in a foreign jurisdiction or any devices intended for implantation in the human body. Should Buyer purchase or use **onsemi** products for any such unintended or unauthorized application, Buyer shall indemnify and hold **onsemi** and its officers, employees, subsidiaries, affiliates, and distributors harmless against all claims, costs, damages, and expenses, and reasonable attorney fees arising out of, directly or indirectly, any claim of personal injury or death associated with such unintended or unauthorized use, even if such claim alleges that **onsemi** was negligent regarding the design or manufacture of the part. **onsemi** is an Equal Opportunity/Affirmative Action Employer. This literature is subject to all applicable copyright laws and is not for resale in any manner. Other names and brands may be claimed as the property of others.

NUD4001 Dimming Ability Demonstration Board

Prepared by: Fionn Sheerin
ON Semiconductor



ON Semiconductor®

<http://onsemi.com>

APPLICATION NOTE

General Description

The NUD4001 produces a constant current to power LEDs, using an external resistor to determine the current level. This works well for applications which require a constant brightness from the LEDs (on or off). In applications which require the LED to dim, or to operate at moderate intensities, a pulse width modulated signal can be used to vary the intensity of the LED by switching it on and off at high frequencies (greater than 100 Hz). This turns out to be a very straightforward circuit, requiring few components and giving a full dimming range from completely off to completely on.

The NUD4001 dimming demonstration board demonstrates this circuit. It can be built with an external transistor to handle voltages up to 18 V (instead of 6 V), and it can use either a single LED on the board or it can connect to an external LED. It can also be built without the dimming circuit, providing a constant output current without the dimming ability.

Features:

- Adjustable LED brightness
- Constant LED current when LED is on
- Minimal external circuit requirements

NUD4001 Overview

The high current LED driver (NUD4001) uses an external resistor to determine the output current. The resistor is connected between the first and third pins of the device, and the output current is:

$$I_{\text{out}} = \frac{0.7 \text{ V}}{R_{\text{ext}}}$$

The LED driver also has an input voltage (Pin 1), and a ground (Pin 4, see Figure 2). If the ground pin is disconnected, then the device stops functioning. The circuit used in the dimming demonstration board takes advantage of this requirement to switch the device on and off.

The dimming demonstration board features an external transistor in parallel with the NUD4001, which decreases the power dissipated in the LED driver, allowing larger currents and higher input voltages (see AND8197/D, NUD4001 LED Driver Demonstration Boards).

Basic Circuit Operation

The dimming demonstration board runs on 6 VDC without the external transistor, or up to 18 VDC with the external transistor (at 350 mA output current). This input can be applied either to the test points labeled "VDC", or using a DC supply connected to the 2.1 mm power jack (labeled "CON1"). The board has two possible LED configurations, one with an LED, and one with a connector to drive a load not on the demo board. If the connector is used to drive an LED in parallel with the LED on the board, the two LEDs must have the same voltage drop (or else they will not share the current evenly), and the current limit resistor on the LED driver needs to be adjusted to supply the proper current to the parallel LEDs. When running, the potentiometer can be used to adjust the duty cycle of the timer circuit, which turns the LED drivers on and off; which reduces the average current through the LEDs. The circuit also contains one jumper, in series with the load, which may be used to connect an ammeter in series with the load to monitor the current regulation.

Power Consumption and Voltage Constraints

Ignoring power dissipation, the board can operate at any voltage between 6 V and 18 V, provided the input voltage is at least 1.4 V higher than the total V_f of the LED load. However, with this board design, the LED driver cannot dissipate more than 1.1 W of power without the external transistor. Using the external transistor, the drive current will flow primarily through the external transistor, which has a maximum power dissipation of 5.3 W (at an ambient temperature of 25°C, with the heatsink on this particular board). The power dissipated in the LED driver can be easily calculated by subtracting the V_f of the load from the input voltage, to get the voltage across the driving circuit, and then multiplying by the load current.

$$P = (V_{\text{in}} - V_{\text{LED}}) \cdot I_{\text{LED}}$$

For this board, the power must remain below 1.1 W without the external transistor, and below 5.3 W with the external transistor. If, for example, this board is built with the external transistor, connected to one LED with a 2.9 V V_f , driving a current of 350 mA, then the circuit could

operate between 6 V and 18 V ($(5.3 \text{ W} / 0.35 \text{ A}) + 2.9 \text{ V} = 18 \text{ V}$). Alternatively, if the circuit were built without the external transistor, driving 3 LEDs in series, each with a 3.2 V V_f , at 300 mA, then the circuit could operate between 11 V and 13.2 V ($(1.1 \text{ W} / 0.3 \text{ A}) + 3 * 3.2 \text{ V} = 13.2 \text{ V}$). Due to the voltage requirements of the timer chip, however, the input voltage must always be between 6 V and 18 V, regardless of the power dissipation.

Circuit Details

The dimming application demonstration board uses an ON Semiconductor MC1455 timer chip (which is identical to a 555 timer chip) to generate a PWM signal which is connected to an NPN bipolar transistor base. This connects or disconnects the ground pin on the current driver to ground. When the timer output is low, the NPN transistor disconnects the LED driver from ground, and when the timer output is high the NPN transistor restores the ground connection, allowing the LED driver to turn on again (see Figure 1 for schematic, see Figure 4 for output waveforms).

In addition, the timer output also charges and discharges a capacitor connected to the input on the timer (C2), so it triggers itself and alternates states. The charge and discharge path of the trigger capacitor go through diodes (D1 and D2), to ensure that the charge and discharge times are different, and through opposite ends of a potentiometer (P1), which can be used to adjust the duty cycle. When the timer input is low, and the output is high, the input capacitor charges through one diode, and through one side of the potentiometer, until the input rises high enough to change the output. When the output is low, and the input is high, the input capacitor discharges through the other side of the potentiometer and a separate diode, allowing the potentiometer to control the duty cycle. When the potentiometer is set at one end, the timer output is almost constantly at one voltage, while a median setting on the potentiometer creates more balanced duty cycle. This signal is then sent through a simple RC filter (R2 and C1), which imposes a maximum switching frequency (approximately 1 kHz), but prevents the current driver from turning on during the fast switches at the highest and lowest possible

duty cycles. The duty cycle of the timer controls how much time the LED current driver spends on, so it directly scales the apparent intensity of the LED. A 50% duty cycle only appears about half as bright as a 100% duty cycle. Because of the RC filter, a 0% duty cycle is completely off, and a 100% duty cycle is completely on. In addition, the timer chip is operating at a frequency of about 500 Hz, so the LED does not appear to be flashing on and off. This frequency can be adjusted using the capacitor on the input of the timer chip (C2), and the frequency could be reduced to make the LED flash visibly if desired. The timer frequency could be set to any value below the cutoff frequency of the RC filter (1 kHz). Finally, a shunt resistor (500 k Ω) is used in parallel with the load. This shunts charge when the circuit is off, to prevent the LED load from glowing faintly.

Alternate Board Configurations

The dimming demonstration board can be built in a number of configurations. The board can be built with or without the external transistor, which determines affects the maximum power consumption in the LED driver circuit. The board can also be built without the dimming function, if the pads of J2 are shorted to permanently connect the ground pin of the NUD4001 to ground, bypassing the PWM circuit (which can then be left off the board entirely, see Figures 6 and 7 for pictures of example board configurations). It can also be built with an LED soldered directly onto the board, or with a connector to drive an external load (note that if an LED is connected directly to the board, it should be attached to the board with thermal epoxy to dissipate the heat in the LED).

Circuit Testing

The circuit can be tested to verify that it works correctly. The jumper at J1 can be replaced by a wire clipped on to the jumper terminals, and the current through the wire can then be measured with a current probe. This is the current flowing through the LED, and except for small changes caused by temperature variations in the NUD4001, this current should remain constant (see Figure 6 for the V_{in}/I_{out} regulation curves).

AND8234/D

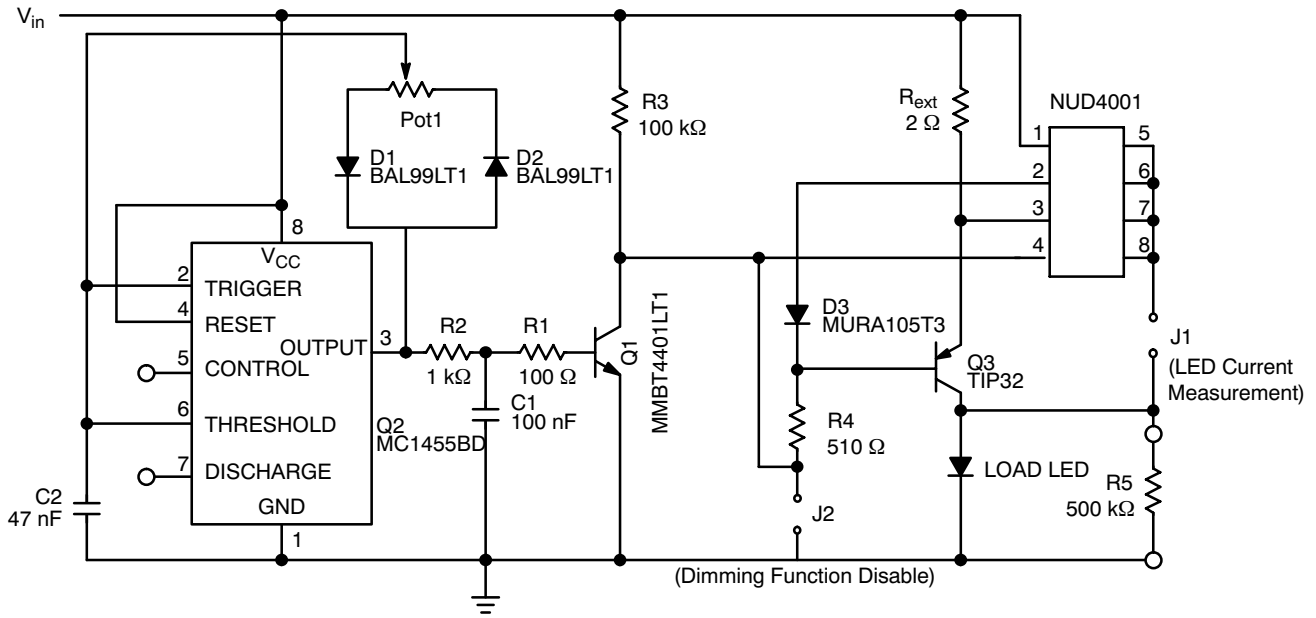

Figure 1. PWM Circuit Diagram

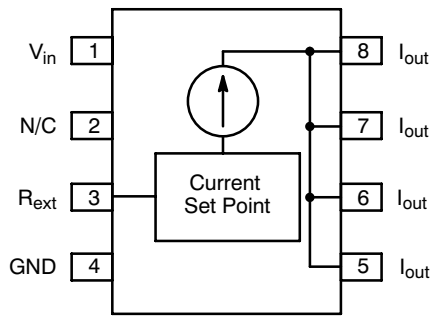

Figure 2. Pinout for NUD4001

AND8234/D

Table 1. BILL OF MATERIALS

Man. Part #	Manufacturer	Description	Quantity	Location
NUD4001	ON Semiconductor	High Current LED Driver	1	LED Driver
		2 Ω Resistor (1206)	2	R _{ext}
		500 k Ω Resistor (0805)	1	R5
PJ-102A	CUI Inc	Power Connector	1	CON1
535676-5	TYCO	Output Connector	1	CON2
		Jumpers	1	J1
1211	Keystone	Test Points	2	+VDC-
SJ-5003	3M	Rubber Feet	3	

Optional Dimming Circuit

MMBT4401LT1	ON Semiconductor	NPN Transistor	1	Q1
MC1455BD	ON Semiconductor	Timing Chip	1	Q2
BAL99LT1	ON Semiconductor	Small Signal Diodes	2	D1, D2
C2012X7R1H104K	TDK	100 nF Capacitor	1	C1
C3216X7R2E473M	TDK	47 nF Capacitor	1	C2
		100 Ω Resistor (0805)	1	R1
		1 k Ω Resistor (0805)	1	R2
		100 k Ω Resistor (0805)	1	R3
EVU-F3AF30850	Panasonic	50 k Ω Potentiometer	1	Pot1

Optional External Transistor

MUR105T3	ON Semiconductor	Rectifier	1	D3
		510 Ω Resistor (1206)	1	R4
TIP32C	ON Semiconductor	PNP Power Transistor	1	Q3
6022pb	AVVID	Heatsink	1	Q3

Optional Onboard LED

LXHL-MW1D	Lumileds	High Current LED	1	LED
-----------	----------	------------------	---	-----

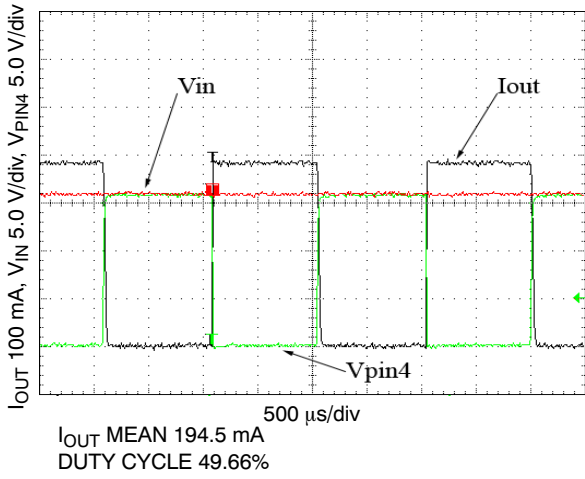

Figure 3. Circuit Behavior at ~50% Duty Cycle

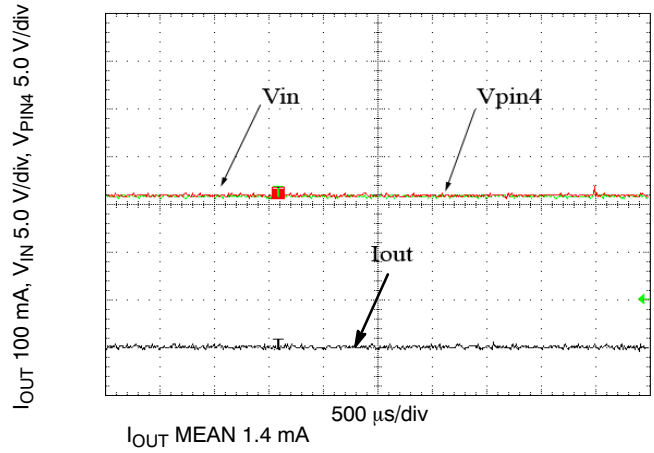

Figure 4. Circuit Behavior at 0% Duty Cycle

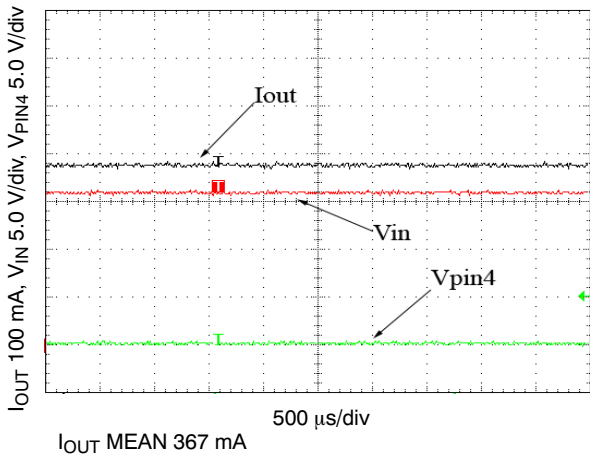

Figure 5. Circuit Behavior at 100% Duty Cycle

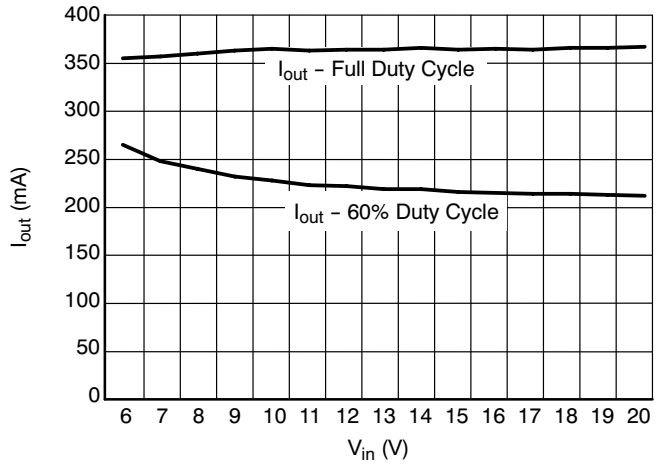

Figure 6. Output Current Regulation at 100% and 60% Duty Cycles

AND8234/D

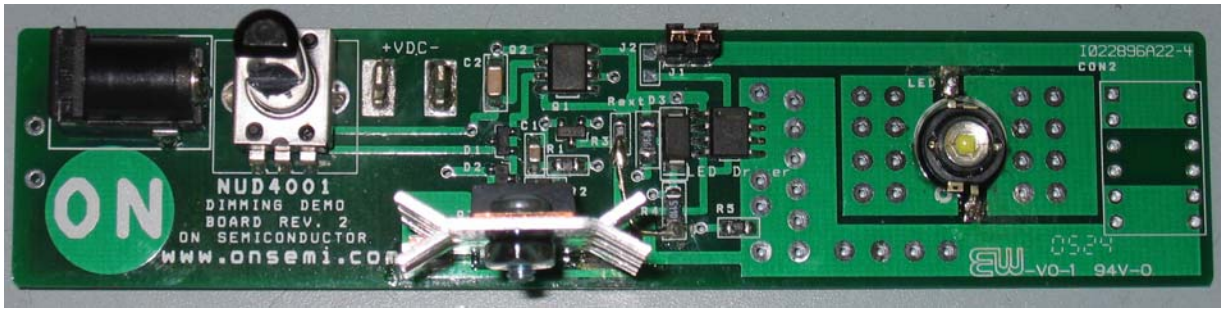

Figure 7. Demonstration Board Built with the Dimming Circuit, the External Transistor, and an Onboard LED

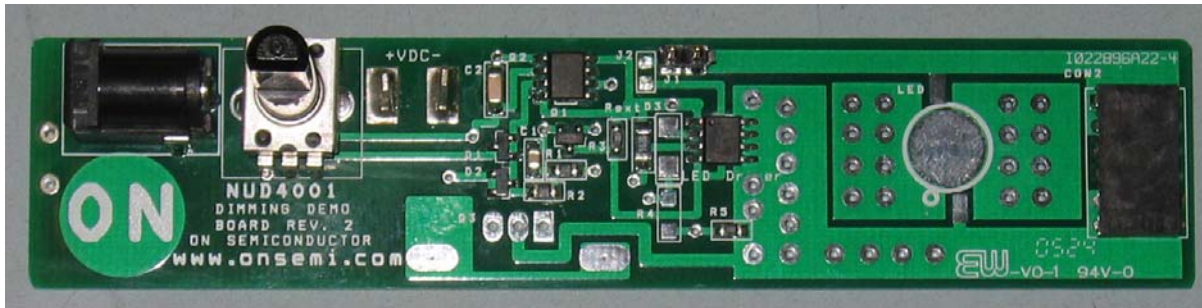

Figure 8. Demonstration Board Built with the Dimming Circuit, Without the External Transistor, and Without the Onboard LED

Table 2. MANUFACTURER CONTACTS

Manufacturer	Contact Information
ON Semiconductor	www.onsemi.com
TDK	(847) 803-6100
Lumileds	www.lumileds.com
Tyco Electronics	www.tycoelectronics.com
3M	www.3m.com
Panasonic	www.panasonic.com

ON Semiconductor and ON are registered trademarks of Semiconductor Components Industries, LLC (SCILLC). SCILLC reserves the right to make changes without further notice to any products herein. SCILLC makes no warranty, representation or guarantee regarding the suitability of its products for any particular purpose, nor does SCILLC assume any liability arising out of the application or use of any product or circuit, and specifically disclaims any and all liability, including without limitation special, consequential or incidental damages. "Typical" parameters which may be provided in SCILLC data sheets and/or specifications can and do vary in different applications and actual performance may vary over time. All operating parameters, including "Typicals" must be validated for each customer application by customer's technical experts. SCILLC does not convey any license under its patent rights nor the rights of others. SCILLC products are not designed, intended, or authorized for use as components in systems intended for surgical implant into the body, or other applications intended to support or sustain life, or for any other application in which the failure of the SCILLC product could create a situation where personal injury or death may occur. Should Buyer purchase or use SCILLC products for any such unintended or unauthorized application, Buyer shall indemnify and hold SCILLC and its officers, employees, subsidiaries, affiliates, and distributors harmless against all claims, costs, damages, and expenses, and reasonable attorney fees arising out of, directly or indirectly, any claim of personal injury or death associated with such unintended or unauthorized use, even if such claim alleges that SCILLC was negligent regarding the design or manufacture of the part. SCILLC is an Equal Opportunity/Affirmative Action Employer. This literature is subject to all applicable copyright laws and is not for resale in any manner.

PUBLICATION ORDERING INFORMATION

LITERATURE FULFILLMENT:
Literature Distribution Center for ON Semiconductor
P.O. Box 5163, Denver, Colorado 80217 USA
Phone: 303-675-2175 or 800-344-3860 Toll Free USA/Canada
Fax: 303-675-2176 or 800-344-3867 Toll Free USA/Canada
Email: orderlit@onsemi.com

N. American Technical Support: 800-282-9855 Toll Free USA/Canada
Europe, Middle East and Africa Technical Support:
Phone: 421 33 790 2910
Japan Customer Focus Center
Phone: 81-3-5773-3850

ON Semiconductor Website: www.onsemi.com
Order Literature: <http://www.onsemi.com/orderlit>
For additional information, please contact your local Sales Representative