



Is Now Part of



ON Semiconductor®

To learn more about ON Semiconductor, please visit our website at
www.onsemi.com

ON Semiconductor and the ON Semiconductor logo are trademarks of Semiconductor Components Industries, LLC dba ON Semiconductor or its subsidiaries in the United States and/or other countries. ON Semiconductor owns the rights to a number of patents, trademarks, copyrights, trade secrets, and other intellectual property. A listing of ON Semiconductor's product/patent coverage may be accessed at www.onsemi.com/site/pdf/Patent-Marking.pdf. ON Semiconductor reserves the right to make changes without further notice to any products herein. ON Semiconductor makes no warranty, representation or guarantee regarding the suitability of its products for any particular purpose, nor does ON Semiconductor assume any liability arising out of the application or use of any product or circuit, and specifically disclaims any and all liability, including without limitation special, consequential or incidental damages. Buyer is responsible for its products and applications using ON Semiconductor products, including compliance with all laws, regulations and safety requirements or standards, regardless of any support or applications information provided by ON Semiconductor. "Typical" parameters which may be provided in ON Semiconductor data sheets and/or specifications can and do vary in different applications and actual performance may vary over time. All operating parameters, including "Typicals" must be validated for each customer application by customer's technical experts. ON Semiconductor does not convey any license under its patent rights nor the rights of others. ON Semiconductor products are not designed, intended, or authorized for use as a critical component in life support systems or any FDA Class 3 medical devices or medical devices with a same or similar classification in a foreign jurisdiction or any devices intended for implantation in the human body. Should Buyer purchase or use ON Semiconductor products for any such unintended or unauthorized application, Buyer shall indemnify and hold ON Semiconductor and its officers, employees, subsidiaries, affiliates, and distributors harmless against all claims, costs, damages, and expenses, and reasonable attorney fees arising out of, directly or indirectly, any claim of personal injury or death associated with such unintended or unauthorized use, even if such claim alleges that ON Semiconductor was negligent regarding the design or manufacture of the part. ON Semiconductor is an Equal Opportunity/Affirmative Action Employer. This literature is subject to all applicable copyright laws and is not for resale in any manner.

AN-8208

Introduction to Automotive Ignition Systems

Introduction

As the cost of gasoline rises and environmental concerns about vehicle exhaust attracts more and more attention, the auto industry is accelerating research on development of new power-train systems with less fuel consumption, higher power density, and enhanced robustness. Being an important part of the power-train system, the ignition system contributes significantly to the system's efficiency, exhaust pollution reduction, and robustness.

In the early 1900s, the inductive ignition system was developed for internal combustion engines. The system and its variants have been in use since that time. In the early days, the primary winding of the ignition coil was controlled by mechanical switches, commonly called the breaker points, which are seldom seen in modern ignition systems. The breaker point inductive ignition system and distributor is simple, low cost, and can be used in most vehicle applications. However, the breaker points are prone to wear out or deteriorate due to burns caused by arcing. Frequent maintenance and replacement increases overall system cost. Some inherent issues related to the mechanical switches and the distributor may also cause the imprecise and/or improper ignition timing. This results in improper fuel mixture burn, causing increased pollution.

Thanks to the development of high-voltage high-current power switches by the semiconductor industry, the vulnerable mechanical switches have been replaced by more reliable, high-power semiconductor devices. By using dual tower coils¹, the distributor can be removed. Using "on plug" type coils, the high-voltage connection wires can be eliminated. The most recent technology trends are integrating the ignition Insulated-Gate Bipolar Transistor (IGBT) into the ignition coil and integrating the IGBT's control IC with diagnosis and protection functions into the single igniter module to make a more compact and simple ignition system. Devices with high clamping voltages and high energy density handling capability (in most cases IGBTs), are desirable as increasing demand for better Miles-Per-Gallon (MPG) engines operating at higher compression ratios need higher sparking voltage and more energy to ignite a lean air-and-fuel mixture.

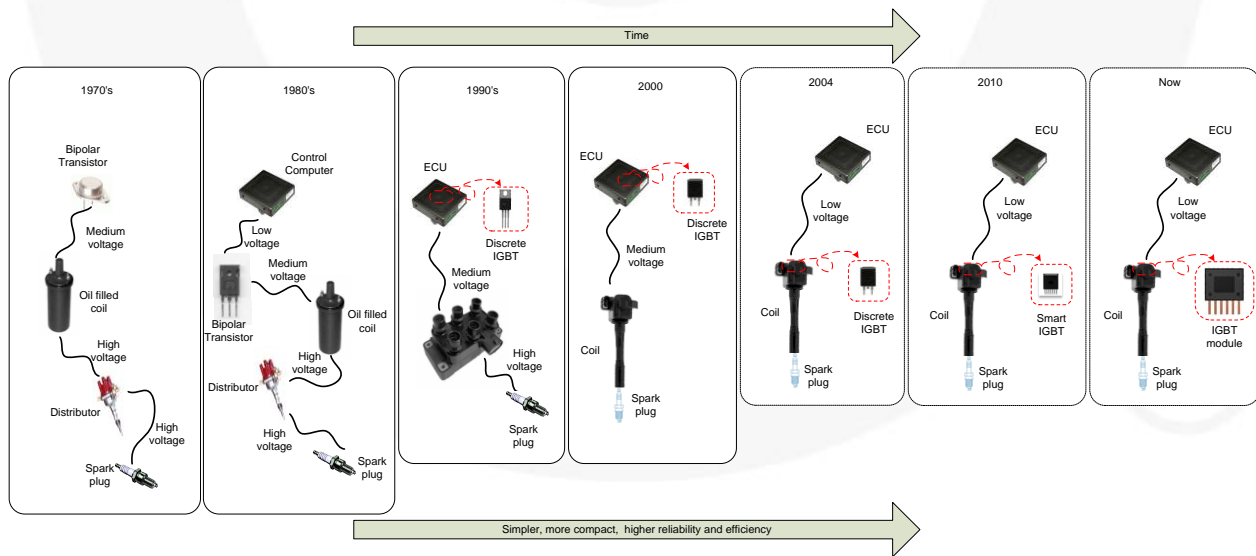

Figure 1. Evolution of the Ignition System

¹ Dual tower coil is the coil used in the waste spark distribution system, where one ignition coil serves for two cylinders, also known as "twin tower" coil.

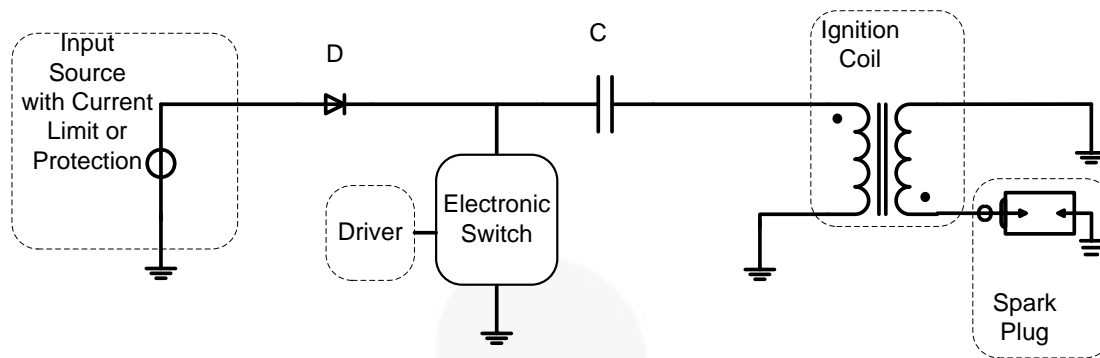

Figure 2. Generic Structure of Capacitor Discharge Ignition (CDI) System

Compared to the mechanical ignition system, the modern electronic ignition system has the following advantages:

- Lower Long-Term Cost through Reduced Maintenance
- Higher and More Consistent Ignition Energy
- More Robust
- Less Volume and Weight
- Precise Ignition Timing Control
- Flexibility for Diagnosis and Protection Schemes
- Higher Reliability

Classic Ignition Systems

There are several classic ignition systems developed for different applications. These can be classified into two groups: Capacitor Discharge Ignition (CDI) systems and Inductive Discharge Ignition (IDI) systems.

Capacitor Discharge Ignition (CDI) System

The CDI system has been widely used in motorcycles, lawn mowers, and other small engines. Compared to the inductive discharge mechanism in IDI systems, CDI system uses capacitor discharge current to fire the spark plug. This gives the CDI system the advantage of fast charging, which is particularly suitable for high-speed engines. The basic structure of CDI system is shown in Figure 2.

Most CDI systems are generally AC-CDI or DC-CDI, depending on the input source. AC-CDI systems obtain energy from the alternator through AC current. DC-CDI systems are powered by the battery through a voltage boosting DC-AC inverter and AC-DC rectifier. Basically, a CDI system consists of a charging circuit, a triggering circuit, an ignition coil, a spark plug, and the energy storage unit (main capacitor).

The input source supplies 250-600 V for the CDI system. This voltage charges the main capacitor, C, through the charging circuit. The diode, D, inside the charging circuit prevents capacitor C from discharging before the desired ignition timing. When the triggering circuit turns on the electronic switch (in most cases, thyristors), the energy within capacitor C discharges into the ignition coil.

Due to the limited energy stored in the capacitor and the low-inductance ignition coil used in CDI systems, the spark duration is relatively short compared to IDI systems. The short spark duration may lead to incomplete combustion, resulting in higher emissions, which excludes the CDI system in applications where a long spark duration is required for reliable ignition.

Inductive Discharge Ignition (IDI) System

Without the “cross-fire”[‡] issue that can occur in a CDI system, and with much longer spark duration, IDI systems are adopted in most of today’s cars. The IDI system operates according to the rules of electromagnetism described by Faraday’s Law of Induction. High voltage is obtained by causing an abrupt change of the magnetic flux in the ignition coil.

A basic IDI system consists of an ignition coil, an ignition IGBT, a drive circuit, a spark plug, and a control unit. Normally, the control unit in an automobile is called the Engine Control Unit (ECU), from which the ignition command signal is created and sent to the ignition IGBT driver. The ECU determines the ignition timing based on the engine speed, temperature, and torque. It also adjusts the exact timing of the spark to provide better power, fuel economy, and emissions. The ECU sends this signal to an IGBT driver, which amplifies the signal and turns on/off the IGBT to control the energy to be charged into the ignition coil and the instance of the spark. The high turns ratio helps reduce the voltage reflected on the primary side caused by the high voltage on the secondary side prior to the sparking event. The general structure of an IDI system is shown in Figure 3.

One ignition coil can be used with either one spark plug (coil-on-plug system) or two spark plugs (distributor-less or waste spark system). The one-coil-two-spark-plugs solution, in which each side of the secondary winding is connected to a spark plug, is more cost efficient than the coil-on-plug system, but compromises performance and leads to faster wear-out of the spark plug.

[‡] Because of the high energy of CDI spark and the high dv/dt , it often fires spark plug in other cylinders through the coupling capacitor between adjacent spark plug leads.

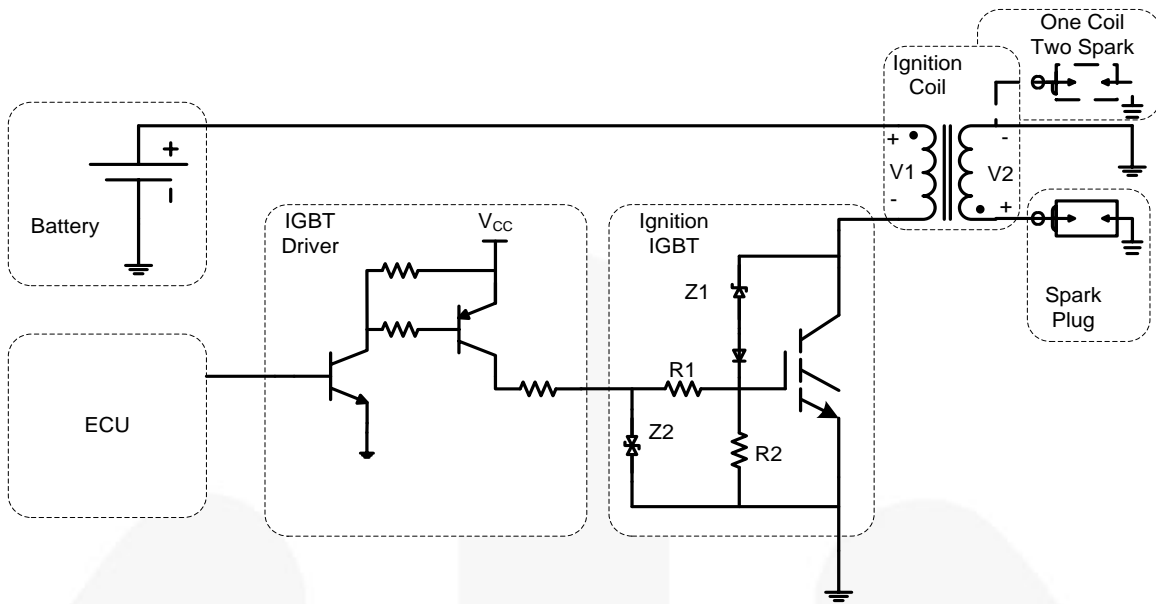

Figure 3. General Structure of Inductive Discharge Ignition (IDI) System

Basic Operations of Inductive Discharge Ignition (IDI) System

The basic operational waveforms of ignition system are shown in Figure 4 and Figure 5. In Figure 4, the waveforms of the dwell portion (primary charging) of the cycle are illustrated; however, the time span of “on command state” depends on the engine speed and control strategy of the ECU. As the command signal (red line) rises to high level, the ignition IGBT is turned on and the current through the primary winding of the ignition coil increases as determined by the coil’s primary inductance. Since the coil’s secondary side is an open circuit before arcing of the spark plug, the energy is temporarily stored in the magnetic core of the coil. Once detecting the proper time to fire the spark plug, the command signal turns back to low level, which results in the ignition IGBT being turned off. The fast change of the primary current induces a high voltage spike across the ignition IGBT as the coil’s leakage inductance is discharged. Normally, ignitions IGBTs have a clamping structure between the gate and collector, like Z1 in Figure 3.

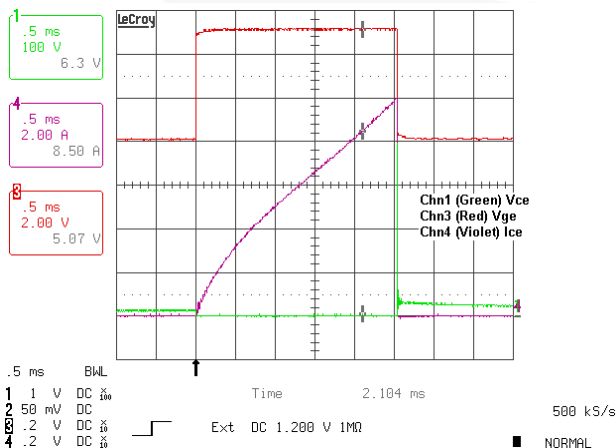

Figure 4. Dwell or Charge Time Operation Waveforms

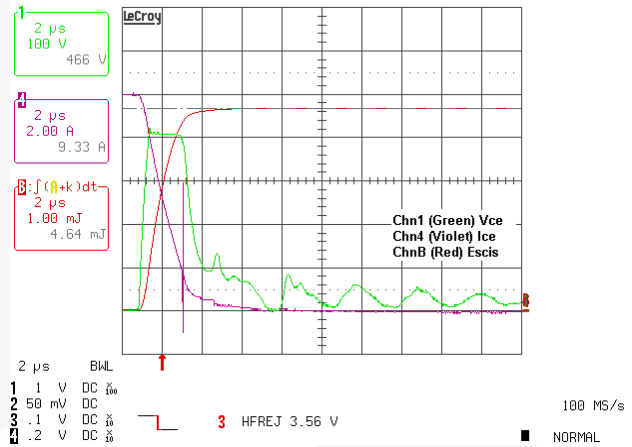

Figure 5. Expanded Turn-Off Waveforms

The clamping structure limits the spike voltage (i.e. to 300 V-600 V) to protect the IGBT and the coil isolation. In Figure 5, the clamping voltage is 400 V, as shown by the green trace. The energy in the leakage inductance builds the voltage spike on the primary side, while the energy in the magnetizing inductance builds the high voltage on the secondary side that generates arcing across the air gap of spark plug.

During the IGBT clamping period, a small current flow, through the clamping structure towards the gate terminal, builds a voltage across the resistor (R1 and R2 in Figure 3) between gate and emitter (ground). This voltage keeps the ignition IGBT operating in Linear Mode under gate control; therefore most of the energy is dissipated in the IGBT portion of the structure instead of the clamping structure. Actually, almost all of energy stored in the leakage inductance of ignition coil is dissipated in the ignition IGBT. For this reason, Self-Clamped Inductive Switching (SCIS) capability is an important parameter to consider when choosing a proper ignition IGBT for a specific ignition coil and is discussed later in this note.

Ignition IGBTs

For different applications, the requirements of spark energy and spark voltage vary, as well as the requirements of the ignition IGBTs.

Ignition Coil - Before Choosing Ignition IGBT

Before choosing an ignition IGBT, there are several parameters of ignition coils that need to be examined: magnetizing inductance, leakage inductance, ESR of primary winding, turns ratio, etc. The equivalent circuit of an ignition coil is shown in Figure 6.

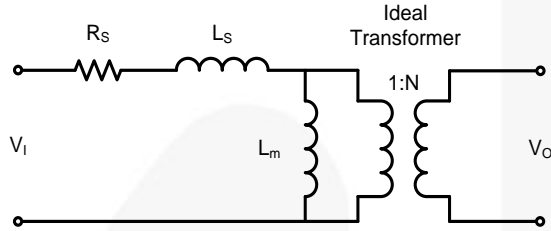

Figure 6. Equivalent Circuit of Ignition Coil

L_s and R_s are the leakage inductance and associated ESR. L_m is the magnetizing inductance. Normally, L_s is in the range of hundreds of micro-henrys, R_s is in the range of 0.1 to 1 Ω , and L_m is in the range of several milli-henrys. The turns ratio of the ideal transformer is about 1:100. In most cases, a several nano-farad capacitor is paralleled with L_m in the ignition coil model, but this capacitor doesn't affect the ignition operation much, so it is not discussed here. These coil parameters may vary according to the design and specific applications.

How to Choose a Basic Ignition IGBT

SCIS Capability

During regular operations, only the energy stored in leakage inductance dissipates in the ignition IGBT. However, under some fault conditions, the energy stored in both leakage and magnetizing inductance is dissipated in the ignition IGBT. A defective spark plug or loose secondary connection can cause arcing across spark gap that does not occur with the turn-off of the ignition IGBT. This is shown in Figure 7.

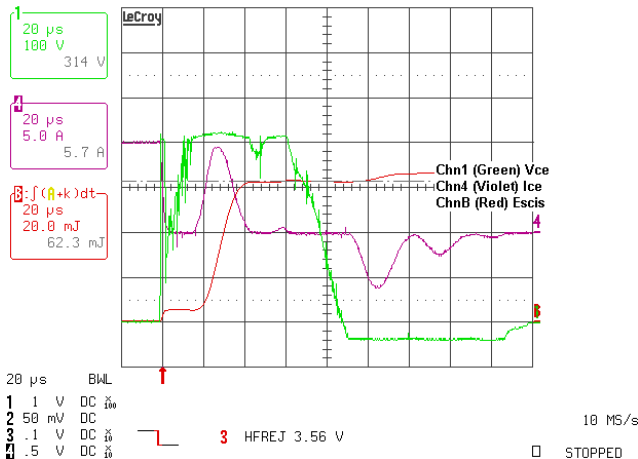

Figure 7. Waveforms of Open Secondary Operation

The SCIS capability of the ignition IGBT should withstand at least the maximum energy in both the leakage and magnetizing inductances of the ignition coil, together with some energy from the battery, which is given by:

$$E = \frac{1}{2}(L_m + L_s)I^2 + \frac{1}{2}IV_{bat}t_{clamp} \tag{1}$$

where I is the peak value of coil primary current, V_{bat} is the battery voltage, and t_{clamp} is the time span of the clamping period.

The second part of the equation is very small compared to the first part, and some energy is also consumed in the ESR of the primary winding, so the second part of Equation 1 could be eliminated, resulting in:

$$E \approx \frac{1}{2}(L_m + L_s)I^2 \tag{2}$$

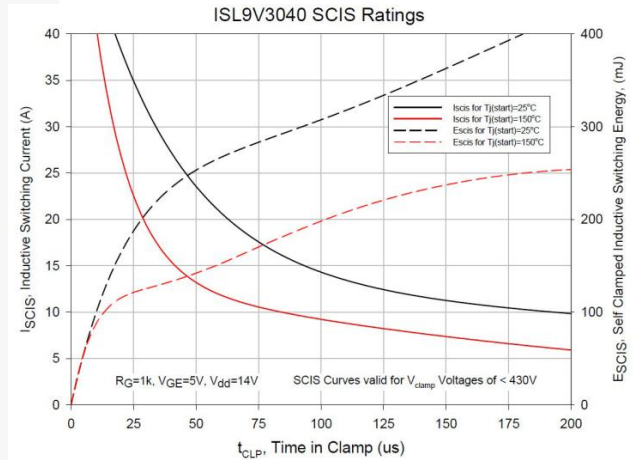

Figure 8. SCIS Capability of ISL9V3040

Since an open secondary situation can occur at any time, the IGBT must be selected to handle this energy level at its elevated operating junction temperature.

Currently, ignition IGBTs are available with SCIS ratings in the range between 200 mJ to 500 mJ, at $T_j=25^\circ\text{C}$. These capabilities decrease as the junction temperature increases, lowering to about half these levels at $T_j=150^\circ\text{C}$.

As shown in Figure 8, the SCIS Safe Operating Area (SOA) of a popular ignition IGBT, ISL9V3040, is on the bottom left of current curves and bottom right of energy curves.

Clamping Voltage

On the IGBT die, an array of back-to-back poly diodes provides active clamping between the collector and gate. The clamping voltage protects the IGBT from entering the Avalanche Mode of operation, which results in current focusing and device failure.

To better understand how the clamping voltage works in ignition systems, refer to Figure 7.

The green trace shows the collector-to-emitter voltage of the IGBT in the open-secondary scenario. As the IGBT turns off, the clamping structure limits the voltage spike caused by leakage inductance to 400 V. A couple of micro-seconds later, this voltage drops as no more energy is left in the leakage inductance. At this point, the voltage across the

IGBT is reflected from the secondary winding. In normal operation, the reflected voltage shouldn't exceed the clamping voltage, so the IGBT won't dissipate the energy in magnetizing inductance. However, as shown in Figure 7, energy that would have been delivered to the spark plug in normal operation is reflected back and needs to be dissipated in the IGBT.

In open-secondary condition, most energy is dissipated in the IGBT no matter how high the clamping voltage. However, in real applications, choosing a proper ignition IGBT while avoiding unnecessary power loss caused by insufficient clamping voltage requires the following items be fully understood.

- Required maximum sparking voltage in normal operation (V_{SPARK_MAX}) depends on the engine design. Leaner air gas mixture or turbo-charged engines need higher ignition voltages.
- There is a trade-off of the ignition coil's turns ratio (T_{ratio}). A higher turns ratio helps reduce the requirement on ignition IGBT's clamping voltage, but complicates the coil design, compromises the coil's performance, and possibly increases the cost of the coil.
- The spark is not ignited by the clamping voltage. Even though the appropriate clamping voltage should be higher than $V_{SPARK_MAX} / T_{ratio}$, the sparking voltage could be much lower than $V_{CLAMP} * T_{ratio}$. During normal operation, the clamping of ignition IGBT at turn-off is mostly caused by the energy stored in the leakage inductance of coil, which isn't transferred to the secondary side in any case.

Collector Current vs. Saturation Voltage

Like most punch-through^{††} devices, at low currents, the ignition IGBT shows negative temperature coefficient ($V_{CE(ON)}$ decreases with temperature at given current). While entering the medium and high current zone, it shows positive temperature coefficient ($V_{CE(ON)}$ increases with temperature at given current).

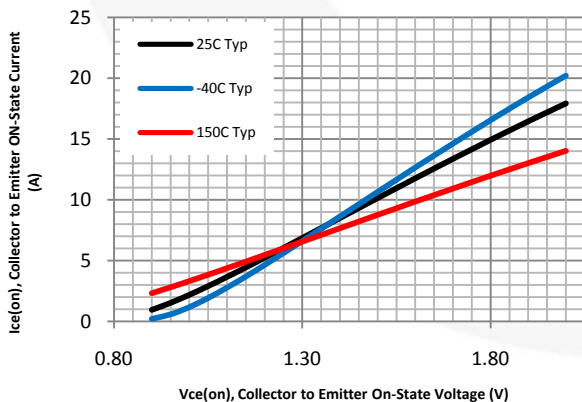

Figure 9. Typical Ignition IGBT $V_{CE(ON)}$ Temperature Characteristic

^{††} Punch-through IGBTs have an extra N^+ buffer layer, which minimizes the leakage current and V_{SAT} , while maximizing breakdown voltage and quickly absorbs trapped holes during turn-off.

The typical temperature characteristic of an ignition IGBT is shown in Figure 9.

The use of the IGBT as the primary switch in an ignition system requires that it be on for a reasonable period of the overall two revolutions of the classic four-stroke engine operation. This is the "dwell" period in which the coil's primary magnetizing inductance is being charged. During this period, the heat produced by the IGBT's conduction loss must be dissipated, so that the IGBT's maximum junction temperature is not exceeded. To minimize this power dissipation, the IGBT should have as low $V_{CE(ON)}$ or V_{SAT} (collector-to-emitter on-state or saturation voltage level) as possible. The EcoSPARK® family offers a good tradeoff between SCIS capability and $V_{CE(ON)}$ performance. Recently, process enhancements and device modeling simulation have enabled the development of the next generation of EcoSPARK® technology that lowers the $V_{CE(ON)}$ even further, while maintaining the industry-leading SCIS performance per unit area of silicon. This performance enhancement is shown in Figure 10.

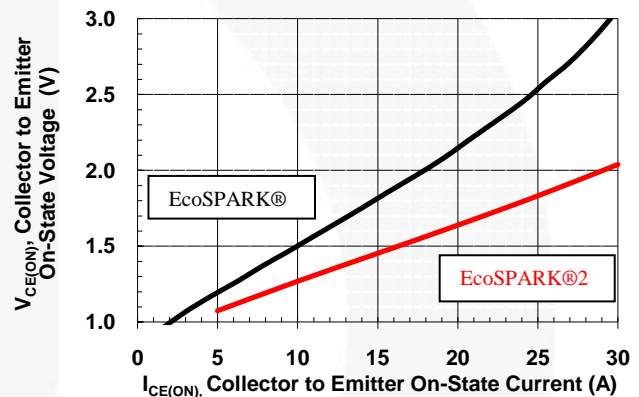

Figure 10. EcoSPARK@2 vs. EcoSPARK@ $V_{CE(ON)}$

Smart Ignition Coil Driver Functions

As the development of ignition systems progressed, more and more functions were added. New features added diagnostics of the system, provided the ability to obtain the status of the fuel mixture burn during combustion, enhanced reliability, and reduced the emissions of the engine. A frequently requested feature of a smart ignition coil driver is the ability to obtain information about the coil's primary current during the dwell time and limit that current to a specific level. This requires the Smart Ignition IGBT to monitor the collector current flowing through it.

Current Sensing

One method of current sensing used in smart ignition coil drivers is a "current-sense IGBT" (refer to the datasheet of [FGBS3040CS](#)), in which on the IGBT a die-level sense channel is built. This is sometimes referred to as a "piloted" IGBT. In this device, the additional emitter sense lead outputs a current proportional to the main collector current. The device schematic is shown in Figure 11.

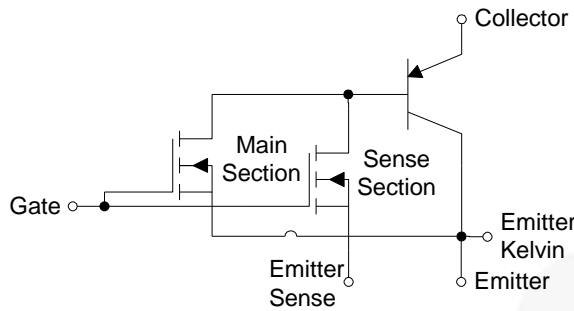

Figure 11. Current Sense IGBT Schematic

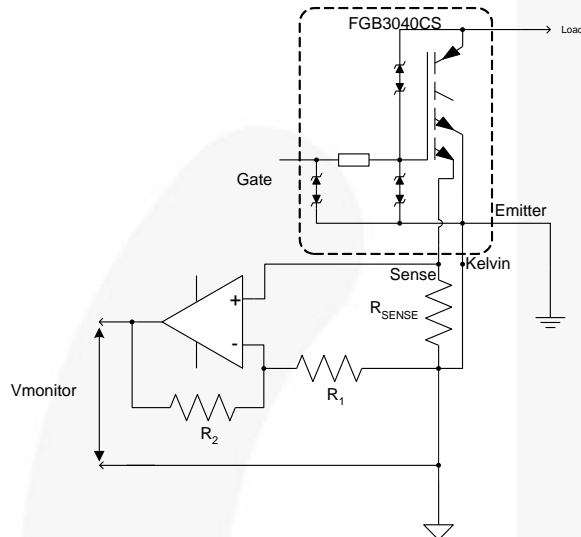

Figure 12. Current Sense IGBT Application Circuit

The simplest way to monitor the current through the sense section is to place a resistor on the emitter sense lead and measure the voltage developed across this resistor. This voltage can be then amplified with an op-amp stage, as shown in Figure 12.

A second method of current sensing is utilizing a high-power, low-value, current-sense resistor or even the bond wire in the emitter current path (outside of IGBT die, but within the package). The monitoring of the current is then obtained by measuring the voltage across the sense resistor or bond wire, as shown in Figure 13.

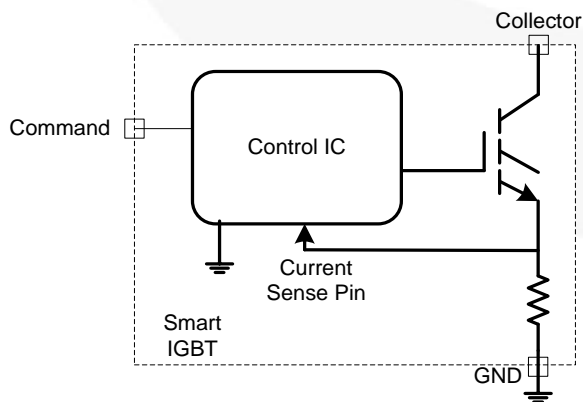

Figure 13. Current Sense using High Current Sense Resistor or Bond Wire

Current-sense IGBTs are a cost effective solution, compared to using high-power current-sense resistors, but the sense ratio varies with the sense resistance and collector current, compromising the accuracy.

Current Limiting

In case of malfunctions of the ECU or anything on the command signal path, the control IC in a smart ignition coil driver usually includes a current-limit function to protect the ignition IGBT, ignition coil, and related components by limiting the charging current to a given level.



Figure 14. Current Limit Waveforms

The current limit level can be fixed in some smart IGBTs, as well as programmable through IC peripheral components in some devices.

Figure 14 shows typical waveforms of current limiting operation. Initially, the gate voltage (pink line) that switches from LOW to HIGH, turns on the IGBT to charge the coil. While collector current (green line) approaches the setting level, the control IC regulates the gate voltage to operate the IGBT in Linear Mode, and thereby limits the current through the ignition IGBT and the coil. The yellow line is the sensed voltage across the emitter current sense resistor.

Soft Shutdown (SSD) & “Max-Dwell” Time

The soft shutdown (SSD) and max-dwell functions are another kind of protection strategy, preventing the devices and components in the power path from getting overheated by an unexpected long charging pulse and avoiding an unwanted spark at turn off. The “max-dwell” is a function of the smart ignition IGBT that sets a maximum time allowed after charging is detected before the IC shuts off the IGBT.



Figure 15. Soft Shutdown (SSD) Waveforms

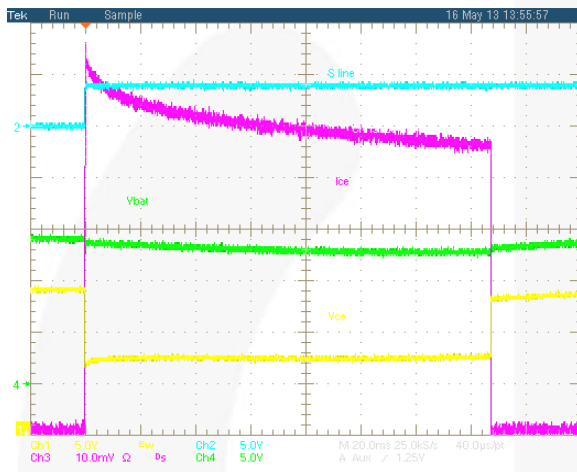

Figure 16. Max-Dwell Waveforms
(Command Signal: Light Blue; Collector Current: Pink; Battery Voltage: Green; IGBT Collector-to-Emitter Voltage: Yellow)

Typical soft shutdown waveforms are shown in Figure 15. The command signal (blue line) keeps a high level once turned on. After the IGBT is turned on, the gate signal (pink line) drops slowly, reducing the collector current smoothly from current limit value until the IGBT totally turns off. The device is inhibited from reactivating the IGBT during the soft shutdown period. This feature normally occurs after a so called “max-dwell” time limit is reached.

The max-dwell function also shuts down the IGBT after a max-dwell time limit is exceeded. However, in this case, the function turns off the IGBT sharply. The waveforms in Figure 16 show the max-dwell operation. A resistive load used in this test shows that the control IC limits the current immediately when the IGBT is turned on. The current drops because of the heating effect of resistive load.

The soft-shutdown current decay rate and the max-dwell time can be fixed within the control IC or programmable with external passive components. The max-dwell function can be designed such that the max-dwell time reduces as the battery voltage increases to prevent the extra energy dissipation in the ignition IGBT, which may be caused by the increased battery voltage.

Input Diagnosis

In some smart ignition coil driver circuits, an input diagnosis function is provided, as shown in Figure 17.



Figure 17. Input Diagnosis Waveforms

The input pin of control IC is designed as a current sink. As the current flowing through the IGBT exceeds a defined value, the input pin current (light blue line) changes. The input current levels and the triggering IGBT current are programmable to be compatible with the engine control unit driver stage employed.

Other Features

In smart ignition applications, other features, like control input buffer, input spike filtering, and over/under-voltage protection, can be designed into the control IC driving the IGBT if needed.

Challenges

The demand of high-MPG vehicles drives the need to develop more efficient engines and advanced ignition systems. The future gasoline engine will feature high compression ratios and lean air gas mixtures. To spark the lean air gas mixture, higher arcing voltage and energy will be required. As a consequence, the ignition IGBTs need to have higher breakdown voltage and sustain higher SCIS energy. High breakdown voltage usually increases cost, but must be solved as power switch technology develops.

One method to provide higher SCIS capability is developing more SCIS-capable IGBTs, an ongoing effort among semiconductor device manufacturers. Another method is using multi-IGBTs, either direct paralleling (low-cost solution) or using interleaved systems (high performance applications), like the dual-coil ignition systems.^[7]

Multi-spark systems^{[8]-[9]} may also be a possible solution, but put more challenges on the whole system design rather than the ignition IGBT itself.

References

- [1] R. K. Jurgen, "Automotive electronics: Ignition systems go solid state: Standard on all 1975 U.S. cars, electronic ignitions reduce maintenance costs, improve cold starts, and keep engines tuned longer," *IEEE Spectrum*, vol.12, no.9, pp.49-51, Sept. 1975.
- [2] R.K. Jurgen, "Automotive Electronics Handbook," 1995, ISBN 0-07-033189-8.
- [3] Leon A. Chavis, "Capacitive-discharge ignition system," U.S. Patent US 3504658 A, April 7, 1970.
- [4] T Us Posey, "Capacitor discharge ignition system," U.S. Patent US 3718125 A, Feb 27, 1973.
- [5] Charles F. Kettering, "Ignition System," U.S. Patent US 1223180 A, April 17, 1917.
- [6] J. Yedinak, J. Merges, J. Wojslawowicz, A. Bhalla, D. Burke, G. Dolny; "Operation of an IGBT in a self-clamped inductive switching circuit (SCIS) for automotive ignition," *Proceedings of the 10th International Symposium on Power Semiconductor Devices & ICs*, pp.399-402, Jun 3-6, 1998.
- [7] Francis Alger II Terrence, Barrett Wade Mangold, Kane Tyler; "Dual coil ignition circuit for spark ignited engine," U.S. Patent US 20090126710 A1, May 21, 2009.
- [8] James Samuel Starr, "Multiple spark electronic ignition system," European Patent EP 0147678 A2, July 10, 1985.
- [9] Carl Rudolph Morganti, Gitanjali Singh, Benjamin David Sweet; "Multi-spark ignition system with variable number of sparks for an internal combustion engine," European Patent EP 0679223 B1, Jun 17, 1998.

Related Resources

[ISL9V3040S F085 — EcoSPARK® 300 mJ, 400 V, N-Channel Ignition](#)

[FGD3040G2 F085 — EcoSPARK® 335 mJ, 400 V, N-Channel Ignition IGBT](#)

[FGD3440G2 F085 — EcoSPARK® 2 335 mJ, 400 V, N-Channel Ignition IGBT](#)

[FGB3040CS F085 — EcoSPARK® 300 mJ, 400 V, N-Channel Current Sensing Ignition IGBT](#)

[ISL9V5036S3ST — EcoSPARK® 500 mJ, 360 V, N-Channel Ignition IGBT](#)

Authors

Qingquan Tang, Jack Wojslawowicz, Hans-Peter Hoenes
 Auto PL Application Team / Fairchild Semiconductor
 Phone +1-570-706-4021
 Fax +1-570-706-4030
 Email Qingquan.tang@fairchildsemi.com

DISCLAIMER

FAIRCHILD SEMICONDUCTOR RESERVES THE RIGHT TO MAKE CHANGES WITHOUT FURTHER NOTICE TO ANY PRODUCTS HEREIN TO IMPROVE RELIABILITY, FUNCTION, OR DESIGN. FAIRCHILD DOES NOT ASSUME ANY LIABILITY ARISING OUT OF THE APPLICATION OR USE OF ANY PRODUCT OR CIRCUIT DESCRIBED HEREIN; NEITHER DOES IT CONVEY ANY LICENSE UNDER ITS PATENT RIGHTS, NOR THE RIGHTS OF OTHERS.

LIFE SUPPORT POLICY

FAIRCHILD'S PRODUCTS ARE NOT AUTHORIZED FOR USE AS CRITICAL COMPONENTS IN LIFE SUPPORT DEVICES OR SYSTEMS WITHOUT THE EXPRESS WRITTEN APPROVAL OF THE PRESIDENT OF FAIRCHILD SEMICONDUCTOR CORPORATION.

As used herein:

1. Life support devices or systems are devices or systems which, (a) are intended for surgical implant into the body, or (b) support or sustain life, or (c) whose failure to perform when properly used in accordance with instructions for use provided in the labeling, can be reasonably expected to result in significant injury to the user.
2. A critical component is any component of a life support device or system whose failure to perform can be reasonably expected to cause the failure of the life support device or system, or to affect its safety or effectiveness.

ON Semiconductor and  are trademarks of Semiconductor Components Industries, LLC dba ON Semiconductor or its subsidiaries in the United States and/or other countries. ON Semiconductor owns the rights to a number of patents, trademarks, copyrights, trade secrets, and other intellectual property. A listing of ON Semiconductor's product/patent coverage may be accessed at www.onsemi.com/site/pdf/Patent-Marking.pdf. ON Semiconductor reserves the right to make changes without further notice to any products herein. ON Semiconductor makes no warranty, representation or guarantee regarding the suitability of its products for any particular purpose, nor does ON Semiconductor assume any liability arising out of the application or use of any product or circuit, and specifically disclaims any and all liability, including without limitation special, consequential or incidental damages. Buyer is responsible for its products and applications using ON Semiconductor products, including compliance with all laws, regulations and safety requirements or standards, regardless of any support or applications information provided by ON Semiconductor. "Typical" parameters which may be provided in ON Semiconductor data sheets and/or specifications can and do vary in different applications and actual performance may vary over time. All operating parameters, including "Typicals" must be validated for each customer application by customer's technical experts. ON Semiconductor does not convey any license under its patent rights nor the rights of others. ON Semiconductor products are not designed, intended, or authorized for use as a critical component in life support systems or any FDA Class 3 medical devices or medical devices with a same or similar classification in a foreign jurisdiction or any devices intended for implantation in the human body. Should Buyer purchase or use ON Semiconductor products for any such unintended or unauthorized application, Buyer shall indemnify and hold ON Semiconductor and its officers, employees, subsidiaries, affiliates, and distributors harmless against all claims, costs, damages, and expenses, and reasonable attorney fees arising out of, directly or indirectly, any claim of personal injury or death associated with such unintended or unauthorized use, even if such claim alleges that ON Semiconductor was negligent regarding the design or manufacture of the part. ON Semiconductor is an Equal Opportunity/Affirmative Action Employer. This literature is subject to all applicable copyright laws and is not for resale in any manner.

PUBLICATION ORDERING INFORMATION

LITERATURE FULFILLMENT:

Literature Distribution Center for ON Semiconductor
19521 E. 32nd Pkwy, Aurora, Colorado 80011 USA
Phone: 303-675-2175 or 800-344-3860 Toll Free USA/Canada
Fax: 303-675-2176 or 800-344-3867 Toll Free USA/Canada
Email: orderlit@onsemi.com

N. American Technical Support: 800-282-9855 Toll Free
USA/Canada
Europe, Middle East and Africa Technical Support:
Phone: 421 33 790 2910
Japan Customer Focus Center
Phone: 81-3-5817-1050

ON Semiconductor Website: www.onsemi.com
Order Literature: <http://www.onsemi.com/orderlit>
For additional information, please contact your local
Sales Representative