



Is Now Part of



**ON Semiconductor®**

To learn more about ON Semiconductor, please visit our website at  
[www.onsemi.com](http://www.onsemi.com)

ON Semiconductor and the ON Semiconductor logo are trademarks of Semiconductor Components Industries, LLC dba ON Semiconductor or its subsidiaries in the United States and/or other countries. ON Semiconductor owns the rights to a number of patents, trademarks, copyrights, trade secrets, and other intellectual property. A listing of ON Semiconductor's product/patent coverage may be accessed at [www.onsemi.com/site/pdf/Patent-Marking.pdf](http://www.onsemi.com/site/pdf/Patent-Marking.pdf). ON Semiconductor reserves the right to make changes without further notice to any products herein. ON Semiconductor makes no warranty, representation or guarantee regarding the suitability of its products for any particular purpose, nor does ON Semiconductor assume any liability arising out of the application or use of any product or circuit, and specifically disclaims any and all liability, including without limitation special, consequential or incidental damages. Buyer is responsible for its products and applications using ON Semiconductor products, including compliance with all laws, regulations and safety requirements or standards, regardless of any support or applications information provided by ON Semiconductor. "Typical" parameters which may be provided in ON Semiconductor data sheets and/or specifications can and do vary in different applications and actual performance may vary over time. All operating parameters, including "Typicals" must be validated for each customer application by customer's technical experts. ON Semiconductor does not convey any license under its patent rights nor the rights of others. ON Semiconductor products are not designed, intended, or authorized for use as a critical component in life support systems or any FDA Class 3 medical devices or medical devices with a same or similar classification in a foreign jurisdiction or any devices intended for implantation in the human body. Should Buyer purchase or use ON Semiconductor products for any such unintended or unauthorized application, Buyer shall indemnify and hold ON Semiconductor and its officers, employees, subsidiaries, affiliates, and distributors harmless against all claims, costs, damages, and expenses, and reasonable attorney fees arising out of, directly or indirectly, any claim of personal injury or death associated with such unintended or unauthorized use, even if such claim alleges that ON Semiconductor was negligent regarding the design or manufacture of the part. ON Semiconductor is an Equal Opportunity/Affirmative Action Employer. This literature is subject to all applicable copyright laws and is not for resale in any manner.

# AN-8008

## FMS6145 Evaluation Board Application Note

### Description

The FMS6145 evaluation board provides a flexible base for evaluating the performance of the FMS6145. The board operates from a standard supply voltage of +5V  $\pm$ 5%.

The FMS6145 Low Cost Video Filter (LCVF) is intended to replace passive LC filters and drivers with a low-cost integrated device. Five 4th order filters provide improved image quality compared to typical 2nd and 3rd order passive solutions.

### Applications

- Cable set top boxes
- Satellite set top boxes
- DVD players
- Personal Video Recorders (PVR)
- Video On Demand (VOD)

For a complete description of the FMS6145 please refer to the FMS6145 data sheet.

### Evaluation Board Block Diagram

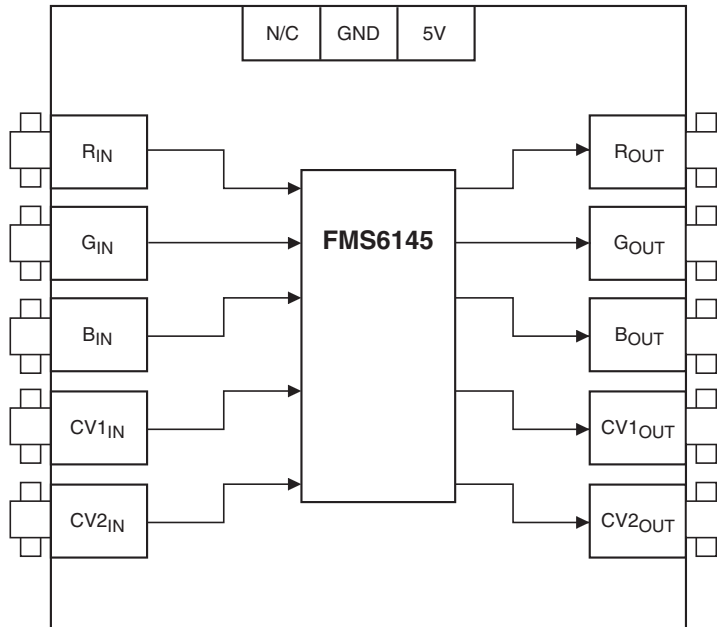

## Evaluation Kit Contents

The FMS6145 Evaluation Kit contains the following items:

- AN-8008 – FMS6145 Evaluation Board Application Note
- The latest revision of the FMS6145 data sheet, which also can be obtained from <http://www.fairchildsemi.com>.
- Fully functional FMS6145 eval board
- Female power connector

## Board Setup and Test

Use the following procedure to verify that the FMS6145 eval board is functional. This only verifies functionality. These instructions do not test any parameters outlined in the datasheet. The following test equipment is necessary to test the FMS6145 eval board.

- One power supply +5V  $\pm$ 5%, 250mA
- One high resolution CRT monitor (2 channel with RGB)
- One NTSC or PAL video signal source capable of generating necessary outputs (RGB, Y, C & Composite)
- One video measurement set (VM700)
- Assorted video cables

DO NOT turn on power supply until all connections are completed.

1. Set the power supply to 5.0V. Connect the power supply to the input voltage terminals of the evaluation board.
2. Connect the R<sub>OUT</sub> signal from the signal source to the R<sub>IN</sub> connector on the FMS6145 eval board.
3. Connect the G<sub>OUT</sub> signal from the signal source to the G<sub>IN</sub> connector on the FMS6145 eval board.
4. Connect the B<sub>OUT</sub> signal from the signal source to the B<sub>IN</sub> connector on the FMS6145 eval board.
5. Connect R<sub>IN</sub> of the monitor to the R<sub>OUT</sub> connector on the FMS6145 eval board.
6. Connect G<sub>IN</sub> of the monitor to the G<sub>OUT</sub> connector on the FMS6145 eval board.
7. Connect B<sub>IN</sub> of the monitor to the B<sub>OUT</sub> connector on the FMS6145 eval board.
8. Turn on the power supply.
9. Verify monitor is setup to receive RGB signals.
10. Verify test pattern that is produced from the generator is the same as the pattern on the monitor screen.
11. Turn off the power supply
12. Connect CV<sub>OUT</sub> of the monitor to the CV<sub>1IN</sub> connector on the FMS6145 eval board.
13. Connect CV<sub>IN</sub> of the monitor to the CV<sub>1OUT</sub> connector on the FMS6145 eval board.
14. Turn on the power supply.
15. Verify monitor is setup to receive composite video.
16. Verify test pattern that is produced from the generator is the same as the pattern on the monitor screen.
17. Turn off the power supply.
18. Connect CV<sub>OUT</sub> of the monitor to the CV<sub>2IN</sub> connector on the FMS6145 eval board.
19. Connect CV<sub>IN</sub> of the monitor to the CV<sub>2OUT</sub> connector on the FMS6145 eval board.
20. Turn on the power supply.
21. Verify monitor is setup to receive composite video (if not done previously).
22. Verify test pattern that is produced from the generator is the same as the pattern on the monitor screen.
23. Functional test is now complete.

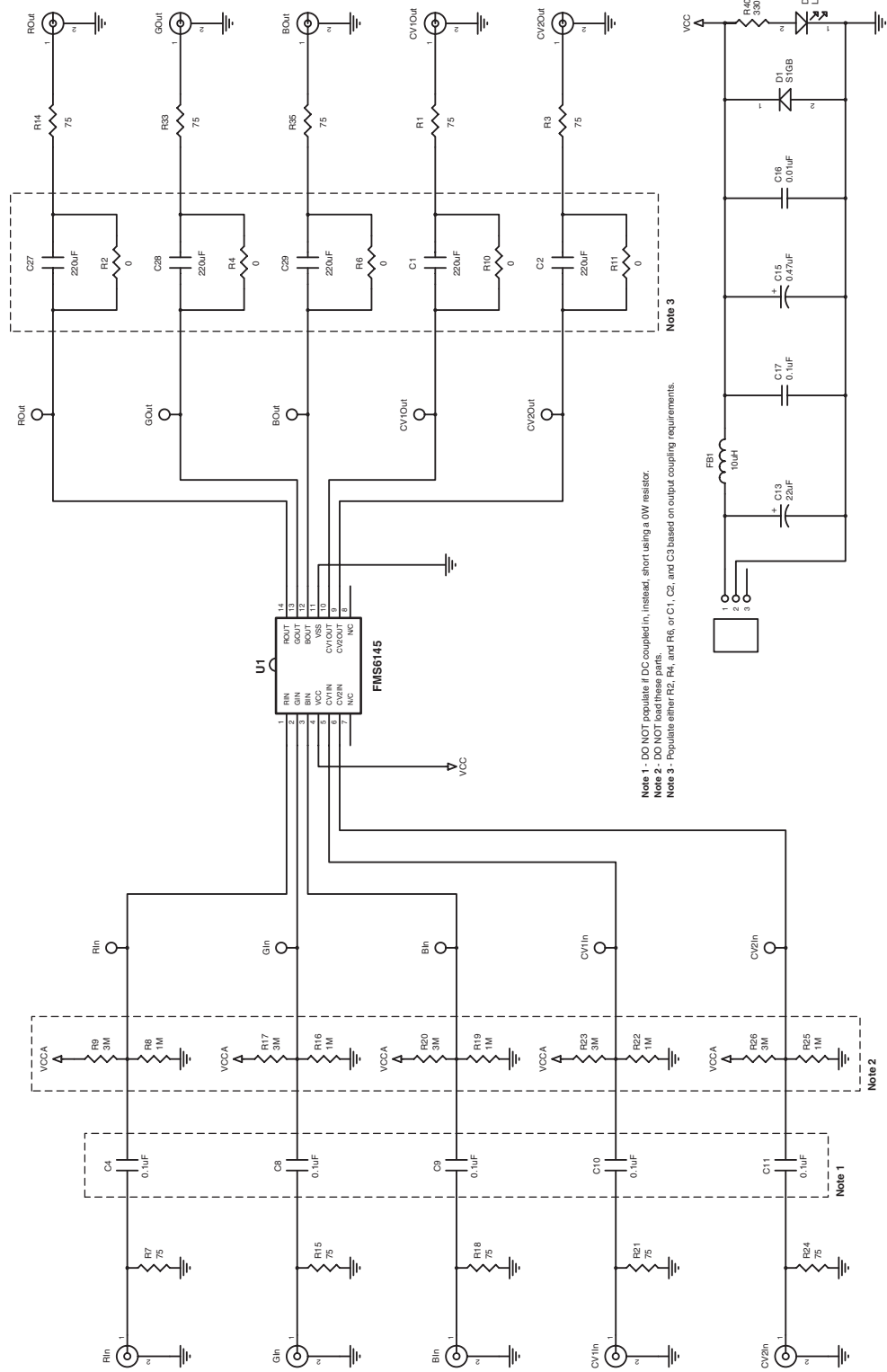

Figure 1. FMS6145 Schematic Diagram

## Bill of Materials

Item	Quantity	Reference	Part
1	10	CV1OUT, CV1IN, CV2OUT, CV2IN, ROUT, RIN, GOUT, GIN, BOUT, BIN	BNC Connectors
2	5	C1, C2, C27, C28, C29	220 $\mu$ F
3	6	C4, C8, C9, C10, C11, C17	0.1 $\mu$ F
4	1	C13	22 $\mu$ F
5	1	C15	0.47 $\mu$ F
6	1	C16	0.01 $\mu$ F
7	1	D1	S1GB
8	1	D2	LED
9	1	FB1	10 $\mu$ H
10	1	JP1	PWRCON3
11	10	R1, R3, R7, R14, R15, R18, R21, R24, R33, R35	75 $\Omega$
12	5	R2, R4, R6, R10, R11	0 $\Omega$
13	5	R8, R16, R19, R22, R25	1M $\Omega$
14	5	R9, R17, R20, R23, R26	3M $\Omega$
15	1	R40	330 $\Omega$
16	1	U1	FMS6145

## Applications

The FMS6145 may be directly driven by a DC-coupled DAC output or an AC-coupled signal. Internal diode clamps and bias circuitry may be used if AC-coupled inputs are required. The outputs can drive AC or DC-coupled single (150 $\Omega$ ) or dual (75 $\Omega$ ) loads. DC-coupling the output removes the need for output coupling capacitors. The input DC levels will be offset approximately +280mV at the output. The FMS6145 Low Cost Video Filter (LCVF) provides 6dB gain from input to output. In addition, the input will be slightly offset to optimize the output driver performance. The FMS6145 provides an internal diode clamp to support AC-coupled input signals. If the input signal does not go below ground, the input clamp will not operate. This allows DAC outputs to directly drive the FMS6145 without an AC coupling capacitor (usually 220 $\mu$ F). The offset is held to the minimum required value to decrease the standing DC current into the load.

## Layout Considerations

General layout and supply bypassing play major roles in high frequency performance and thermal characteristics. The FMS6145DEMO board is a 4-layer board with a full power and ground plane. Following this layout configuration will provide the optimum performance and thermal characteristics. For optimum results, follow the steps below as a basis for high frequency layout.

- Include 10 $\mu$ F and 0.1 $\mu$ F ceramic bypass capacitors
- Place the 10 $\mu$ F capacitor within 0.75 inches of the power pin
- Place the 0.1 $\mu$ F capacitor within 0.1 inches of the power pin
- For multi-layer boards, use a large ground plane to help dissipate heat
- For 2 layer boards, use a ground plane that extends beyond the device by at least 0.5 inches
- Minimize all trace lengths to reduce series inductance

**TRADEMARKS**

The following are registered and unregistered trademarks Fairchild Semiconductor owns or is authorized to use and is not intended to be an exhaustive list of all such trademarks.

ACEx™	FAST®	ISOPLANAR™	PowerSaver™	SuperSOT™-8
ActiveArray™	FASTr™	LittleFET™	PowerTrench®	SyncFET™
Bottomless™	FPST™	MICROCOUPLER™	QFET®	TinyLogic®
Build it Now™	FRFET™	MicroFET™	QS™	TINYOPTO™
CoolFET™	GlobalOptoisolator™	MicroPak™	QT Optoelectronics™	TruTranslation™
CROSSVOLT™	GTO™	MICROWIRE™	Quiet Series™	UHC™
DOMET™	HiSeC™	MSX™	RapidConfigure™	UltraFET®
EcoSPARK™	I <sup>2</sup> C™	MSXPro™	RapidConnect™	UniFET™
E <sup>2</sup> CMOS™	i-Lo™	OCX™	µSerDes™	VCX™
EnSigna™	ImpliedDisconnect™	OCXPro™	SILENT SWITCHER®	Wire™
FACT™	IntelliMAX™	OPTOLOGIC®	SMART START™	
FACT Quiet Series™		OPTOPLANAR™	SPM™	
Across the board. Around the world.™		PACMAN™	Stealth™	
The Power Franchise®		POP™	SuperFET™	
Programmable Active Droop™		Power247™	SuperSOT™-3	
		PowerEdge™	SuperSOT™-6	

**DISCLAIMER**

FAIRCHILD SEMICONDUCTOR RESERVES THE RIGHT TO MAKE CHANGES WITHOUT FURTHER NOTICE TO ANY PRODUCTS HEREIN TO IMPROVE RELIABILITY, FUNCTION OR DESIGN. FAIRCHILD DOES NOT ASSUME ANY LIABILITY ARISING OUT OF THE APPLICATION OR USE OF ANY PRODUCT OR CIRCUIT DESCRIBED HEREIN; NEITHER DOES IT CONVEY ANY LICENSE UNDER ITS PATENT RIGHTS, NOR THE RIGHTS OF OTHERS.

**LIFE SUPPORT POLICY**

FAIRCHILD'S PRODUCTS ARE NOT AUTHORIZED FOR USE AS CRITICAL COMPONENTS IN LIFE SUPPORT DEVICES OR SYSTEMS WITHOUT THE EXPRESS WRITTEN APPROVAL OF FAIRCHILD SEMICONDUCTOR CORPORATION. As used herein:

- |   |   |
|---|---|
| <p>1. Life support devices or systems are devices or systems which, (a) are intended for surgical implant into the body, or (b) support or sustain life, or (c) whose failure to perform when properly used in accordance with instructions for use provided in the labeling, can be reasonably expected to result in significant injury to the user.</p> | <p>2. A critical component is any component of a life support device or system whose failure to perform can be reasonably expected to cause the failure of the life support device or system, or to affect its safety or effectiveness.</p> |
|---|---|

**PRODUCT STATUS DEFINITIONS**

**Definition of Terms**

Datasheet Identification	Product Status	Definition
Advance Information	Formative or In Design	This datasheet contains the design specifications for product development. Specifications may change in any manner without notice.
Preliminary	First Production	This datasheet contains preliminary data, and supplementary data will be published at a later date. Fairchild Semiconductor reserves the right to make changes at any time without notice in order to improve design.
No Identification Needed	Full Production	This datasheet contains final specifications. Fairchild Semiconductor reserves the right to make changes at any time without notice in order to improve design.
Obsolete	Not In Production	This datasheet contains specifications on a product that has been discontinued by Fairchild semiconductor. The datasheet is printed for reference information only.

Rev. 116

ON Semiconductor and  are trademarks of Semiconductor Components Industries, LLC dba ON Semiconductor or its subsidiaries in the United States and/or other countries. ON Semiconductor owns the rights to a number of patents, trademarks, copyrights, trade secrets, and other intellectual property. A listing of ON Semiconductor's product/patent coverage may be accessed at [www.onsemi.com/site/pdf/Patent-Marking.pdf](http://www.onsemi.com/site/pdf/Patent-Marking.pdf). ON Semiconductor reserves the right to make changes without further notice to any products herein. ON Semiconductor makes no warranty, representation or guarantee regarding the suitability of its products for any particular purpose, nor does ON Semiconductor assume any liability arising out of the application or use of any product or circuit, and specifically disclaims any and all liability, including without limitation special, consequential or incidental damages. Buyer is responsible for its products and applications using ON Semiconductor products, including compliance with all laws, regulations and safety requirements or standards, regardless of any support or applications information provided by ON Semiconductor. "Typical" parameters which may be provided in ON Semiconductor data sheets and/or specifications can and do vary in different applications and actual performance may vary over time. All operating parameters, including "Typicals" must be validated for each customer application by customer's technical experts. ON Semiconductor does not convey any license under its patent rights nor the rights of others. ON Semiconductor products are not designed, intended, or authorized for use as a critical component in life support systems or any FDA Class 3 medical devices or medical devices with a same or similar classification in a foreign jurisdiction or any devices intended for implantation in the human body. Should Buyer purchase or use ON Semiconductor products for any such unintended or unauthorized application, Buyer shall indemnify and hold ON Semiconductor and its officers, employees, subsidiaries, affiliates, and distributors harmless against all claims, costs, damages, and expenses, and reasonable attorney fees arising out of, directly or indirectly, any claim of personal injury or death associated with such unintended or unauthorized use, even if such claim alleges that ON Semiconductor was negligent regarding the design or manufacture of the part. ON Semiconductor is an Equal Opportunity/Affirmative Action Employer. This literature is subject to all applicable copyright laws and is not for resale in any manner.

## PUBLICATION ORDERING INFORMATION

### LITERATURE FULFILLMENT:

Literature Distribution Center for ON Semiconductor  
19521 E. 32nd Pkwy, Aurora, Colorado 80011 USA  
**Phone:** 303-675-2175 or 800-344-3860 Toll Free USA/Canada  
**Fax:** 303-675-2176 or 800-344-3867 Toll Free USA/Canada  
**Email:** [orderlit@onsemi.com](mailto:orderlit@onsemi.com)

**N. American Technical Support:** 800-282-9855 Toll Free  
USA/Canada  
**Europe, Middle East and Africa Technical Support:**  
Phone: 421 33 790 2910  
**Japan Customer Focus Center**  
Phone: 81-3-5817-1050

**ON Semiconductor Website:** [www.onsemi.com](http://www.onsemi.com)  
**Order Literature:** <http://www.onsemi.com/orderlit>  
For additional information, please contact your local  
Sales Representative