



Is Now Part of



**ON Semiconductor®**

To learn more about ON Semiconductor, please visit our website at  
[www.onsemi.com](http://www.onsemi.com)

ON Semiconductor and the ON Semiconductor logo are trademarks of Semiconductor Components Industries, LLC dba ON Semiconductor or its subsidiaries in the United States and/or other countries. ON Semiconductor owns the rights to a number of patents, trademarks, copyrights, trade secrets, and other intellectual property. A listing of ON Semiconductor's product/patent coverage may be accessed at [www.onsemi.com/site/pdf/Patent-Marking.pdf](http://www.onsemi.com/site/pdf/Patent-Marking.pdf). ON Semiconductor reserves the right to make changes without further notice to any products herein. ON Semiconductor makes no warranty, representation or guarantee regarding the suitability of its products for any particular purpose, nor does ON Semiconductor assume any liability arising out of the application or use of any product or circuit, and specifically disclaims any and all liability, including without limitation special, consequential or incidental damages. Buyer is responsible for its products and applications using ON Semiconductor products, including compliance with all laws, regulations and safety requirements or standards, regardless of any support or applications information provided by ON Semiconductor. "Typical" parameters which may be provided in ON Semiconductor data sheets and/or specifications can and do vary in different applications and actual performance may vary over time. All operating parameters, including "Typicals" must be validated for each customer application by customer's technical experts. ON Semiconductor does not convey any license under its patent rights nor the rights of others. ON Semiconductor products are not designed, intended, or authorized for use as a critical component in life support systems or any FDA Class 3 medical devices or medical devices with a same or similar classification in a foreign jurisdiction or any devices intended for implantation in the human body. Should Buyer purchase or use ON Semiconductor products for any such unintended or unauthorized application, Buyer shall indemnify and hold ON Semiconductor and its officers, employees, subsidiaries, affiliates, and distributors harmless against all claims, costs, damages, and expenses, and reasonable attorney fees arising out of, directly or indirectly, any claim of personal injury or death associated with such unintended or unauthorized use, even if such claim alleges that ON Semiconductor was negligent regarding the design or manufacture of the part. ON Semiconductor is an Equal Opportunity/Affirmative Action Employer. This literature is subject to all applicable copyright laws and is not for resale in any manner.

## Interfacing Between PECL and LVDS Differential Technologies

### Introduction

Over the past several years, growth in the demand for high-speed data transmission has spawned dramatic changes and innovations in high-speed ICs. Achieving these increased levels of high performance, lower power and improved noise immunity involves optimizing the interface between ICs. Often times a more cost effective solution requires interfacing between ICs with different I/O voltage levels and technology requirements. System designers must familiarize themselves with the different I/O circuit configurations to understand the requirements for proper biasing and effective termination necessary to maintain good signal integrity between differing technologies. This application note will describe an approach to interfacing Positive Emitter Coupled Logic (PECL) with Low Voltage Differential Signaling (LVDS) technologies.

### What is PECL?

Emitter Coupled Logic (ECL) is an ultra-high speed digital logic technology and is based on a differential amplifier. Small signal swings prevent saturation during switching and increase operating frequency performance. The input and output voltage levels are referenced directly to  $V_{CC}/V_{CCA}$  pins which are normally zero volts or ground potential operating with a negative  $V_{EE}$  and negative termination  $V_{TT}$  supplies. With PECL operation the  $V_{CC}/V_{CCA}$  pins are offset to the positive +5V nominal potential,  $V_{TT}$  is offset by +5V from -2V to +3V and the  $V_{EE}$  pin becomes 0V or ground potential. Refer to the schematic representation of the PECL operation and the associated voltage levels in Figure 1.

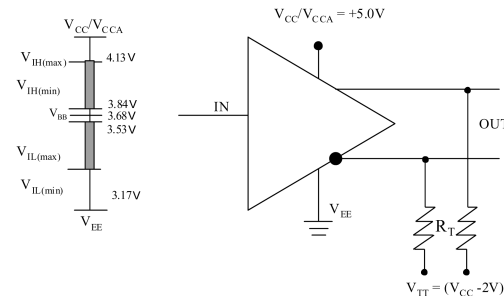

FIGURE 1. ECL Device Configured for PECL Operation

### What is LVDS?

LVDS technology is defined by the ANSI/TIA/EIA-644 industry standard. LVDS is targeted for general purpose high speed applications requiring very low noise and minimal power consumption. Using a constant current source driver allows power consumption to be relatively independent of frequency resulting in greater performance. LVDS drivers have a very low differential swing of typically 350 mV, which is centered on an offset voltage of 1.2V above circuit common (ground). With lower signal swings, higher data rates can be achieved as it takes less time to transition between logic states. Noise concerns are reduced with differential signaling techniques as noise is coupled onto both conductors with equal magnitude and phase and is rejected by the receiver, which senses the difference between the two signals.

TABLE 1. Signal Voltage Comparisons

DC Parameter	5V PECL	LVPECL	LVDS
Power Supply, $V_{CC}$	+5.0V	3.3V	3.3V
Output HIGH, $V_{OH}$	4.0V	2.4V	1.4V
Output LOW, $V_{OL}$	3.3V	1.7V	1.0V
Differential Output, $V_{OD}$	595 to 960 mV	595 to 930 mV	247 to 454 mV
Common Mode Voltage, $V_{OS}$	3.65V	2.1V	1.2V

### 5V PECL to 5V LVDS Interface

For a PECL driver, each emitter follower output is properly terminated with a 50Ω resistor to a termination voltage of  $V_{TT} = V_{CC} - 2V$ . Although this termination technique will consume significantly less power, an additional supply for the termination voltage may be undesirable for the system. The LVDS receiver should have a sufficiently wide common mode range to respond to the output signals from the PECL driver. Figure 2 shows how the interface can be configured using a split resistor termination with a  $V_{TT}$  of  $(V_{CC} - 2V)$ . This configuration consists of a +5V PECL device

driving a 5V LVDS receiver. The configuration is possible providing the receiver has a wide common mode range that accommodates the worst case PECL output levels and compliance to all device datasheet specifications is met. To ensure proper operation of the PECL device within the system the tolerances of the  $V_{TT}$  and  $V_{CC}$  supplies should be considered. Refer to waveforms in Figure 3, illustrating the PECL to LVDS interface operation. Although the configuration conserves power and keeps component count low, an additional power supply is required.

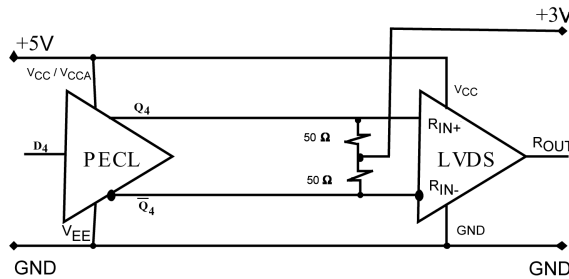

FIGURE 2. PECL to 5V LVDS Interface

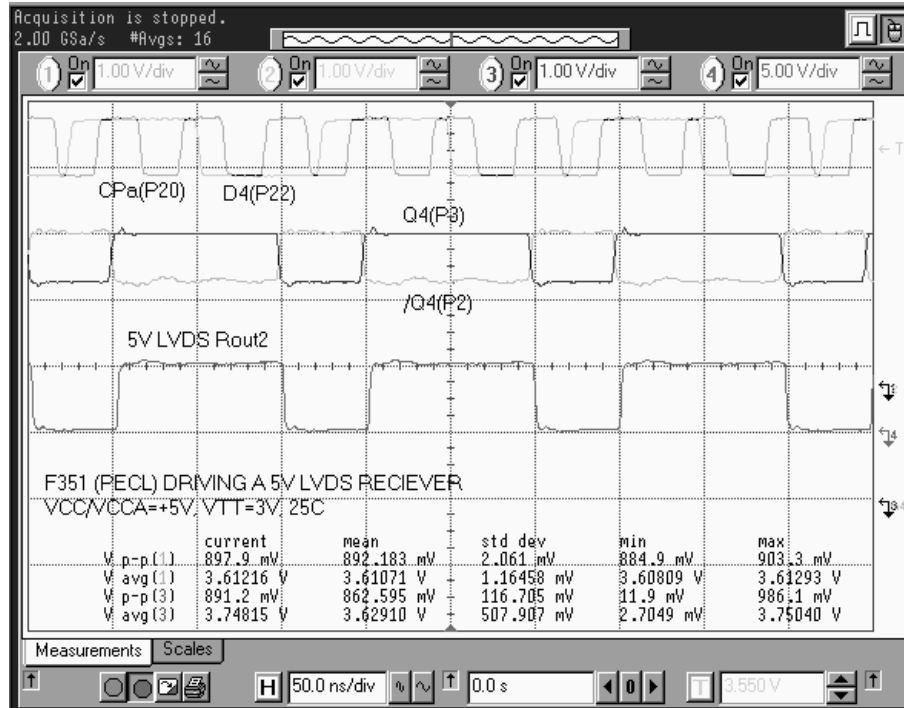

FIGURE 3. PECL to 5V LVDS Interface

### LVPECL to 3V LVDS Interface

A similar bench set up was evaluated using an LVPECL driver with a 1-meter CAT5 Unshielded Twisted Pair (UTP) cable as a 100Ω characteristic impedance transmission media driving a Fairchild FIN1018 LVDS receiver. Although power consumption is significantly less, the parallel termination scheme requires an extra  $V_{TT}$  power supply for the impedance matching load resistor. Depending on the system this extra power supply requirement may prohibit use of this technique. As the number of PECL devices incorpo-

rated in the design increases the more attractive the  $V_{TT}$  termination scheme becomes. Typically, trade-offs between the performance requirements and system costs will dictate which approach the designer will use. The parallel termination technique using an extra  $V_{TT}$  power supply is shown in Figure 4. Refer to the Figure 5 for waveforms of the LVPECL to LVDS interconnect. This configuration conserves power and keeps component count low, however requires an additional supply voltage.

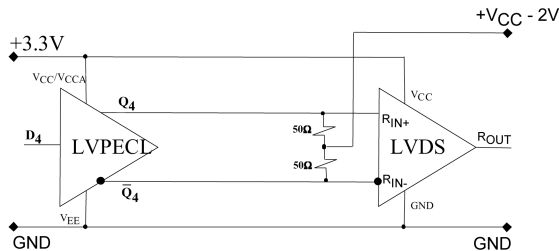
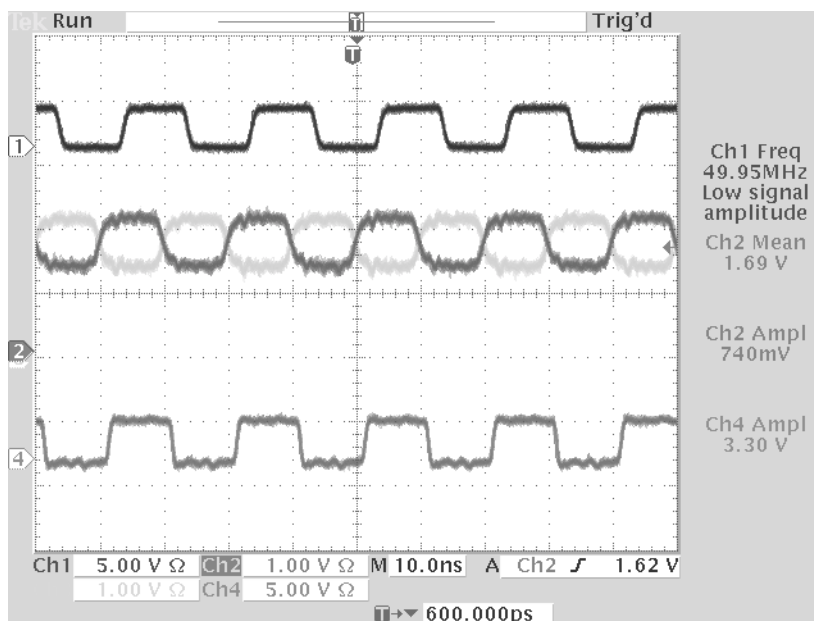

FIGURE 4. LVPECL to 3V LVDS Interface



**Note:** Channel 1: LVTTTL Input  
 Channel 2 and 3: Single Ended LVPECL Outputs  
 Channel 4: LVTTTL Output from LVDS Receiver

FIGURE 5. LVPECL to 3V LVDS Interface

## Thevenin Equivalent Termination Scheme

As previously mentioned, since an LVPECL output is designed to drive a  $50\Omega$  load connected to a  $V_{TT}$  of  $(V_{CC} - 2V)$ , using a termination supply voltage may not be available in the system application. An alternative approach involves using a Thevenin equivalent parallel combination of resistors which is equal to the transmission line impedance and shifts the PECL driver signals to be in the common mode input range of the LVDS receiver using a single supply voltage. This technique will consume more termination power, however the absence of an additional power supply will more than compensate for the extra power consumption. This extra power is consumed entirely in the external resistor network and will not change the current

being sourced by the device, hence will not alter the reliability of the IC.

To explore this approach we will use an LVPECL driver interfacing to a 3V LVDS receiver. A parallel Thevenin termination network as shown in Figure 6 will provide a resistor divider network to generate the proper DC levels for the LVDS receiver. The resistor network ensures the LVPECL outputs are terminated for a  $50\Omega$  load to  $(V_{CC} - 2V)$  and will attenuate the LVPECL output signals to within the input range of the LVDS receiver. While this technique increases the component count and dissipates more termination power, the additional  $V_{TT}$  supply is not required.

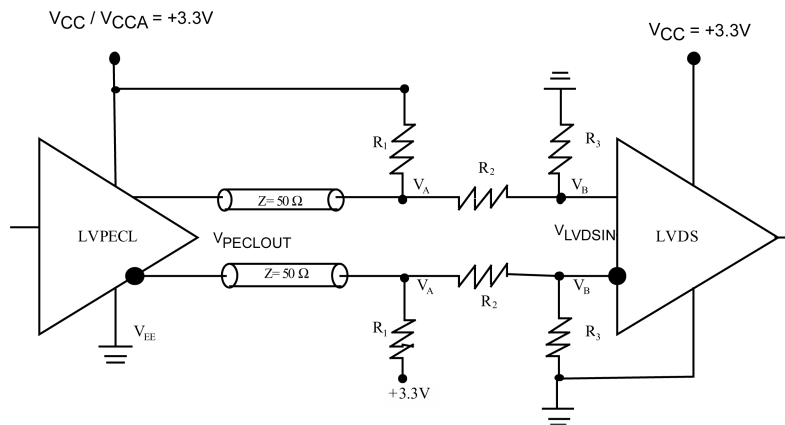

FIGURE 6. LVPECL to LVDS Interface Using a Thevenin Equivalent Termination Scheme

### Thevenin Equivalent Termination Scheme (Continued)

The characteristic line impedance is approximately  $50\Omega$  for each of the single ended lines, therefore the parallel combination of  $R_1 \parallel (R_2 + R_3)$  must provide the correct  $R_T$  of  $50\Omega$ . To illustrate the attenuation resistor network the following equations will be used in the example:

$$\text{Equation 1: } V_A = R_1 / (R_1 + R_2 + R_3) = 2/V_{CC}$$

$$\text{Equation 2: } V_B = R_3 / (R_1 + R_2 + R_3) = V_{IL} / V_{CC}$$

$$\text{Equation 3: } V_{LVDSIN} = R_3 / (R_2 + R_3) * V_{PECLTOUT}$$

#### Example:

Assume the following differential voltage levels

$$V_{LVDSIN} = 350 \text{ mV (typical)}$$

$$V_{PECLTOUT} = 700 \text{ mV (typical)}$$

$$V_{CC} = 3.3V$$

Using Equation 3:

Ratio of  $V_{LVDSIN} / V_{PECLTOUT}$  is  $350 \text{ mV} / 700 \text{ mV} = R_3 / (R_2 + R_3)$ , since it's a 1:2 relationship then  $R_2 = R_3$

$R_1 \parallel (R_2 + R_3) = 50\Omega$  and since  $R_2 = R_3$ , replacing  $R_3$  with  $R_2$  this equation becomes  $R_1 \parallel (2 * R_2) = 50\Omega$

$$\begin{aligned} V_A &= R_1 / (R_1 + R_2 + R_3) = 2/V_{CC} \\ &= R_1 / (R_1 + R_2 + R_3) = 2/3.3V & V_{CC} &= 3.3V \\ &= R_1 / (R_1 + 2R_2) = 0.61V & R_3 &= R_2 \end{aligned}$$

Solve for  $R_1$ :

$$\begin{aligned} R_1 &= 0.61R_1 + 1.22R_2 \\ (1 - 0.61)R_1 &= 1.22R_2 \\ R_1 &= \frac{1.22R_2}{0.39} \\ R_1 &= 3.13R_2 & (R_2 \sim 3 \text{ times larger than } R_1) \end{aligned}$$

Solve for  $R_2$ :

$$\begin{aligned} R_1 \parallel (2R_2) &= 50\Omega \\ \frac{R_1 * 2R_2}{R_1 + 2R_2} &= 50 \\ 2R_1R_2 &= 50R_1 + 100R_2 \\ 2(3.13R_2)R_2 &= 50(3.13R_2) + 100R_2 & R_1 &= 3.13R_2, \text{ replace } R_1 \text{ with } 3.13R_2 \\ R_2 &= 41\Omega \end{aligned}$$

Resistor values are  $R_1 = 128\Omega$ ;  $R_2 = 41\Omega$ ;  $R_3 = 41\Omega$

The results of these calculations are non-standard resistor values, adjust and select the resistor values for the specific application maintaining proper matching of the line impedance and termination of the LVPECL outputs.

## Interfacing LVDS to LVPECL

If an application requires interfacing from LVDS to LVPECL, direct interface is possible provided the LVPECL line receiver has the proper differential common mode input range. Refer to the individual LVPECL device datasheets for the specifications and performance requirements. This solution would simply require a single termina-

tion resistor, typically  $100\Omega$ , for matching the transmission line impedance without any additional attenuation resistor network. Refer to Figure 7. For interfacing LVDS to PECL, direct interface is possible providing the PECL receiver has extended common mode range inputs to process the LVDS signals when supplied with  $5V \pm 5\%$  supply voltage.

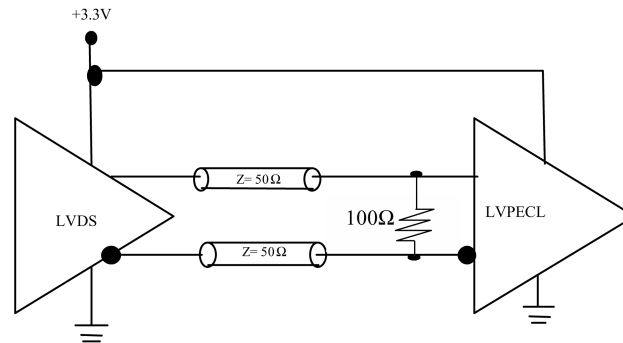

FIGURE 7. LVDS to LVPECL Interface

## Summary

Interfacing between multiple differential technologies presents some challenges to system designers who must evaluate options for a cost-effective solution. Existing system requirements, signal integrity demands and costs will dictate which approach is preferred to minimize risk and optimize the reliability of the system. Although the single resistor termination to  $V_{TT}$  conserves power, the interface requires an additional termination voltage which may be impractical. An alternative approach to an additional power supply is to use a resistor divider network to develop a Thevenin voltage, termination voltage and provide impedance matching termination for the transmission line to mini-

mize reflections. The Thevenin equivalent of the two resistors for each single ended transmission line needs to be equal to the characteristic impedance of the line. Although this scheme will consume more power, this extra power is consumed entirely in the external resistor network and will not change the current being sourced by the device, hence will not alter the reliability of the IC. The approaches illustrated in this application note provide guidelines for understanding the requirements. Compliance to all individual IC maximum ratings should be met to ensure proper system performance.

Fairchild does not assume any responsibility for use of any circuitry described, no circuit patent licenses are implied and Fairchild reserves the right at any time without notice to change said circuitry and specifications.

## LIFE SUPPORT POLICY

FAIRCHILD'S PRODUCTS ARE NOT AUTHORIZED FOR USE AS CRITICAL COMPONENTS IN LIFE SUPPORT DEVICES OR SYSTEMS WITHOUT THE EXPRESS WRITTEN APPROVAL OF THE PRESIDENT OF FAIRCHILD SEMICONDUCTOR CORPORATION. As used herein:

1. Life support devices or systems are devices or systems which, (a) are intended for surgical implant into the body, or (b) support or sustain life, and (c) whose failure to perform when properly used in accordance with instructions for use provided in the labeling, can be reasonably expected to result in a significant injury to the user.
2. A critical component in any component of a life support device or system whose failure to perform can be reasonably expected to cause the failure of the life support device or system, or to affect its safety or effectiveness.

[www.fairchildsemi.com](http://www.fairchildsemi.com)

ON Semiconductor and  are trademarks of Semiconductor Components Industries, LLC dba ON Semiconductor or its subsidiaries in the United States and/or other countries. ON Semiconductor owns the rights to a number of patents, trademarks, copyrights, trade secrets, and other intellectual property. A listing of ON Semiconductor's product/patent coverage may be accessed at [www.onsemi.com/site/pdf/Patent-Marking.pdf](http://www.onsemi.com/site/pdf/Patent-Marking.pdf). ON Semiconductor reserves the right to make changes without further notice to any products herein. ON Semiconductor makes no warranty, representation or guarantee regarding the suitability of its products for any particular purpose, nor does ON Semiconductor assume any liability arising out of the application or use of any product or circuit, and specifically disclaims any and all liability, including without limitation special, consequential or incidental damages. Buyer is responsible for its products and applications using ON Semiconductor products, including compliance with all laws, regulations and safety requirements or standards, regardless of any support or applications information provided by ON Semiconductor. "Typical" parameters which may be provided in ON Semiconductor data sheets and/or specifications can and do vary in different applications and actual performance may vary over time. All operating parameters, including "Typicals" must be validated for each customer application by customer's technical experts. ON Semiconductor does not convey any license under its patent rights nor the rights of others. ON Semiconductor products are not designed, intended, or authorized for use as a critical component in life support systems or any FDA Class 3 medical devices or medical devices with a same or similar classification in a foreign jurisdiction or any devices intended for implantation in the human body. Should Buyer purchase or use ON Semiconductor products for any such unintended or unauthorized application, Buyer shall indemnify and hold ON Semiconductor and its officers, employees, subsidiaries, affiliates, and distributors harmless against all claims, costs, damages, and expenses, and reasonable attorney fees arising out of, directly or indirectly, any claim of personal injury or death associated with such unintended or unauthorized use, even if such claim alleges that ON Semiconductor was negligent regarding the design or manufacture of the part. ON Semiconductor is an Equal Opportunity/Affirmative Action Employer. This literature is subject to all applicable copyright laws and is not for resale in any manner.

## PUBLICATION ORDERING INFORMATION

### LITERATURE FULFILLMENT:

Literature Distribution Center for ON Semiconductor  
19521 E. 32nd Pkwy, Aurora, Colorado 80011 USA  
**Phone:** 303-675-2175 or 800-344-3860 Toll Free USA/Canada  
**Fax:** 303-675-2176 or 800-344-3867 Toll Free USA/Canada  
**Email:** [orderlit@onsemi.com](mailto:orderlit@onsemi.com)

**N. American Technical Support:** 800-282-9855 Toll Free  
USA/Canada  
**Europe, Middle East and Africa Technical Support:**  
Phone: 421 33 790 2910  
**Japan Customer Focus Center**  
Phone: 81-3-5817-1050

**ON Semiconductor Website:** [www.onsemi.com](http://www.onsemi.com)  
**Order Literature:** <http://www.onsemi.com/orderlit>  
For additional information, please contact your local  
Sales Representative