



Is Now Part of



**ON Semiconductor®**

To learn more about ON Semiconductor, please visit our website at

[www.onsemi.com](http://www.onsemi.com)

ON Semiconductor and the ON Semiconductor logo are trademarks of Semiconductor Components Industries, LLC dba ON Semiconductor or its subsidiaries in the United States and/or other countries. ON Semiconductor owns the rights to a number of patents, trademarks, copyrights, trade secrets, and other intellectual property. A listing of ON Semiconductor's product/patent coverage may be accessed at [www.onsemi.com/site/pdf/Patent-Marking.pdf](http://www.onsemi.com/site/pdf/Patent-Marking.pdf). ON Semiconductor reserves the right to make changes without further notice to any products herein. ON Semiconductor makes no warranty, representation or guarantee regarding the suitability of its products for any particular purpose, nor does ON Semiconductor assume any liability arising out of the application or use of any product or circuit, and specifically disclaims any and all liability, including without limitation special, consequential or incidental damages. Buyer is responsible for its products and applications using ON Semiconductor products, including compliance with all laws, regulations and safety requirements or standards, regardless of any support or applications information provided by ON Semiconductor. "Typical" parameters which may be provided in ON Semiconductor data sheets and/or specifications can and do vary in different applications and actual performance may vary over time. All operating parameters, including "Typicals" must be validated for each customer application by customer's technical experts. ON Semiconductor does not convey any license under its patent rights nor the rights of others. ON Semiconductor products are not designed, intended, or authorized for use as a critical component in life support systems or any FDA Class 3 medical devices or medical devices with a same or similar classification in a foreign jurisdiction or any devices intended for implantation in the human body. Should Buyer purchase or use ON Semiconductor products for any such unintended or unauthorized application, Buyer shall indemnify and hold ON Semiconductor and its officers, employees, subsidiaries, affiliates, and distributors harmless against all claims, costs, damages, and expenses, and reasonable attorney fees arising out of, directly or indirectly, any claim of personal injury or death associated with such unintended or unauthorized use, even if such claim alleges that ON Semiconductor was negligent regarding the design or manufacture of the part. ON Semiconductor is an Equal Opportunity/Affirmative Action Employer. This literature is subject to all applicable copyright laws and is not for resale in any manner.

# CMOS Schmitt Trigger—A Uniquely Versatile Design Component

Fairchild Semiconductor  
Application Note 140  
June 1975



CMOS Schmitt Trigger—A Uniquely Versatile Design Component

## INTRODUCTION

The Schmitt trigger has found many applications in numerous circuits, both analog and digital. The versatility of a TTL Schmitt is hampered by its narrow supply range, limited interface capability, low input impedance and unbalanced output characteristics. The Schmitt trigger could be built from discrete devices to satisfy a particular parameter, but this is a careful and sometimes time-consuming design.

The CMOS Schmitt trigger, which comes six to a package, uses CMOS characteristics to optimize design and advance into areas where TTL could not go. These areas include: interfacing with op amps and transmission lines, which operate from large split supplies, logic level conversion, linear operation, and special designs relying on a CMOS characteristic. The CMOS Schmitt trigger has the following advantages:

- High impedance input ( $10^{12}\Omega$  typical)
  - Balanced input and output characteristics
    - Thresholds are typically symmetrical to  $\frac{1}{2} V_{CC}$
    - Outputs source and sink equal currents
    - Outputs drive to supply rails
  - Positive and negative-going thresholds show low variation with respect to temperature
  - Wide supply range (3V–15V), split supplies possible
  - Low power consumption, even during transitions
  - High noise immunity, 0.70  $V_{CC}$  typical
- Applications demonstrating how each of these characteristics can become a design advantage will be given later in the application note.

## ANALYZING THE CMOS SCHMITT

The input of the Schmitt trigger goes through a standard input protection and is tied to the gates of four stacked devices. The upper two are P-channel and the lower two are

N-channel. Transistors P3 and N3 are operating in the source follower mode and introduce hysteresis by feeding back the output voltage, out', to two different points in the stack.

When the input is at 0V, transistors P1 and P2 are ON, and N1, N2 and P3 are OFF. Since out' is high, N3 is ON and acting as a source follower, the drain of N1, which is the source of N2, is at  $V_{CC} - V_{TH}$ . If the input voltage is ramped up to one threshold above ground transistor N1 begins to turn ON, N1 and N3 both being ON form a voltage divider network biasing the source of N2 at roughly half the supply. When the input is a threshold above  $\frac{1}{2} V_{CC}$ , N2 begins to turn ON and regenerative switching is about to take over. Any more voltage on the input causes out' to drop. When out' drops, the source of N3 follows its gate, which is out', the influence of N3 in the voltage divider with N1 rapidly diminishes, bringing out' down further yet. Meanwhile P3 has started to turn ON, its gate being brought low by the rapidly dropping out'. P3 turning ON brings the source of P2 low and turns P2 OFF. With P2 OFF, out' crashes down. The snapping action is due to greater than unity loop gain through the stack caused by positive feedback through the source follower transistors. When the input is brought low again an identical process occurs in the upper portion of the stack and the snapping action takes place when the lower threshold is reached.

Out' is fed into the inverter formed by P4 and N4; another inverter built with very small devices, P5 and N5, forms a latch which stabilizes out'. The output is an inverting buffer capable of sinking 360  $\mu A$  or two LPTTL loads.

The typical transfer characteristics are shown in *Figure 2*; the guaranteed trip point range is shown in *Figure 3*.

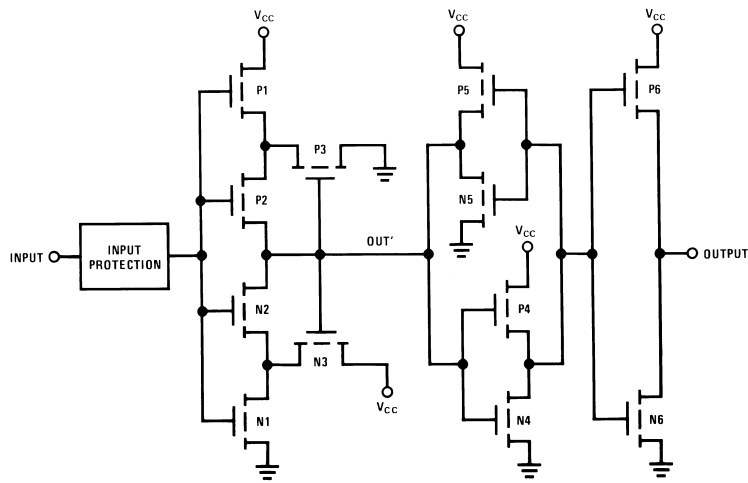

FIGURE 1. CMOS Schmitt Trigger

AN006024-1

### WHAT HYSTERESIS CAN DO FOR YOU

Hysteresis is the difference in response due to the direction of input change. A noisy signal that traverses the threshold of a comparator can cause multiple transitions at the output, if the response time of the comparator is less than the time between spurious effects. A Schmitt trigger has two thresholds: any spurious effects must be greater than the threshold difference to cause multiple transitions. With a CMOS Schmitt at  $V_{CC} = 10V$  there is typically 3.6V of threshold difference, enough hysteresis to overcome almost any spurious signal on the input.

A comparator is often used to recover information sent down an unbalanced transmission line. The threshold of the comparator is placed at one half the signal amplitude (See Figure 4b). This is done to prevent slicing level distortion. If a 4  $\mu s$  wide signal is sent down a transmission line a 4  $\mu s$  wide signal should be received or signal distortion occurs. If the comparator has a threshold above half the signal amplitude, then positive pulses sent are shorter and negative pulses are lengthened (See Figure 4c). This is called slicing level distortion. The Schmitt trigger does have a positive offset,  $V_{T+}$ , but it also has a negative offset  $V_{T-}$ . In CMOS these offsets are approximately symmetrical to half the signal level so a 4  $\mu s$  wide pulse sent is also recovered (see Figure 4d). The recovered pulse is delayed in time but the length is not changed, so noise immunity is achieved and signal distortion is not introduced because of threshold offsets.

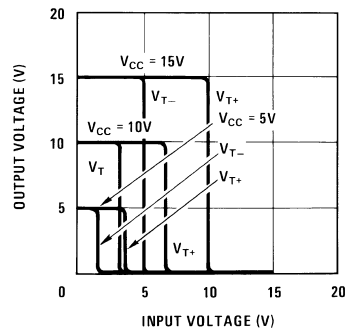

AN006024-2

FIGURE 2. Typical CMOS Transfer Characteristics for Three Different Supply Voltages

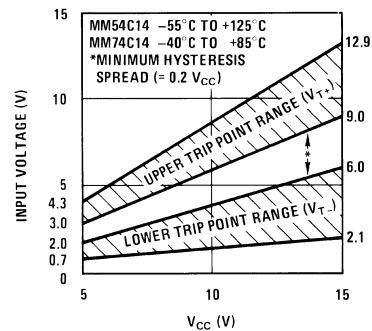

AN006024-3

FIGURE 3. Guaranteed Trip Point Range

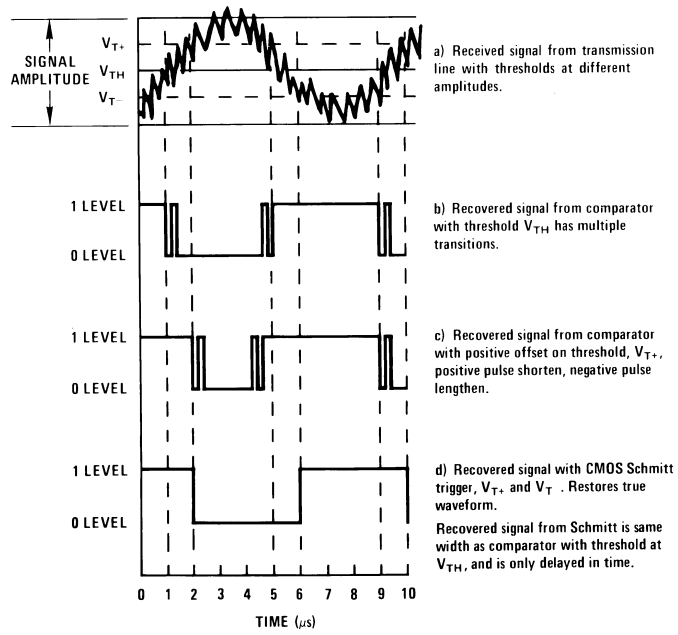

AN006024-4

FIGURE 4. CMOS Schmitt Trigger Ignores Noise

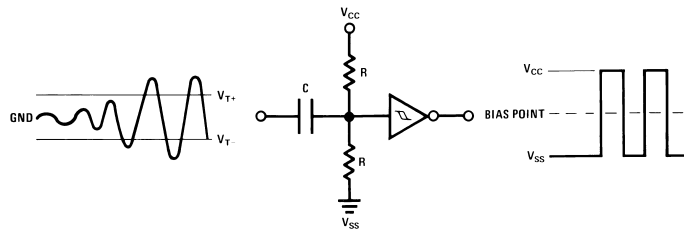

AN006024-5

a) Capacitor impedance at lowest operating frequency should be much less than  $R \parallel R = \frac{1}{2}R$ .

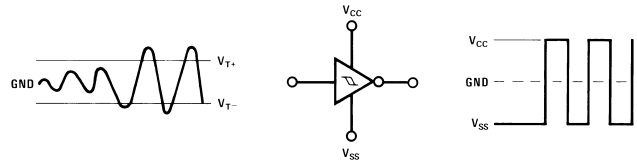

AN006024-6

b) By using split supply ( $\pm 1.5V$  to  $\pm 7.5V$ ) direct interface is achieved.  
**FIGURE 5. Sine to Square Wave Converter with Symmetrical Level Detection**

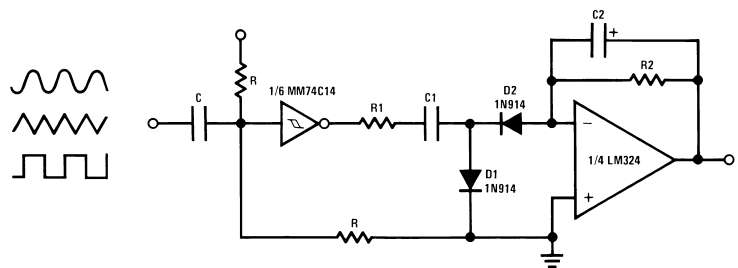

AN006024-7

Where  $R1C1 \cong 1/f_{MAX}$  and  $R2C2 \cong$  response time of voltmeter  
 $V_{OUT} = fR2C1\Delta$  where  $\Delta V = V_{CC}$

**FIGURE 6. Diode Dump Tach Accepts any Input Waveform**

**APPLICATIONS OF THE CMOS SCHMITT**

Most of the following applications use a CMOS Schmitt characteristic to either simplify design or increase performance. Some of the applications could not be done at all with another logic family.

The circuit in *Figure 5a* is the familiar sine to square wave converter. Because of input symmetry the Schmitt trigger is easily biased to achieve a 50% duty cycle. The high input impedance simplifies the selection of the biasing resistors and coupling capacitor. Since CMOS has a wide supply range the Schmitt trigger could be powered from split supplies (see *Figure 5b*). This biases the mean threshold value around zero and makes direct coupling from an op amp output possible.

In *Figure 4*, we see a frequency to voltage converter that accepts many waveforms with no change in output voltage. Although the energy in the waveforms are quite different, it is only the frequency that determines the output voltage. Since the output of the CMOS Schmitt pulls completely to the supply rails, a constant voltage swing across capacitor C1 causes a current to flow through the capacitor, dependent only on frequency. On positive output swings, the current is

dumped to ground through D1. On negative output swings, current is pulled from the inverting op amp node through D2 and transformed into an average voltage by R2 and C2.

Since the CMOS Schmitt pulls completely to the supply rails the voltage change across the capacitor is just the supply voltage.

Schmitt triggers are often used to generate fast transitions when a slowly varying function exceeds a predetermined level. In *Figure 7*, we see a typical circuit, a light activated switch. The high impedance input of the CMOS Schmitt trigger makes biasing very easy. Most photo cells are several  $k\Omega$  brightly illuminated and a couple  $M\Omega$  dark. Since CMOS has a  $10^{12}$  typical input impedance, no effects are felt on the input when the output changes. The selection of the biasing resistor is just the solution of a voltage divider equation.

A CMOS application note wouldn't be complete without a low power application. *Figure 8* shows a simple RC oscillator. With only six R's and C's and one Hex CMOS trigger, six low power oscillators can be built. The square wave output is approximately 50% duty cycle because of the balanced input and output characteristics of CMOS. The output frequency equation assumes that  $t_1 = t_2 \geq t_{pd0} + t_{pd1}$ .

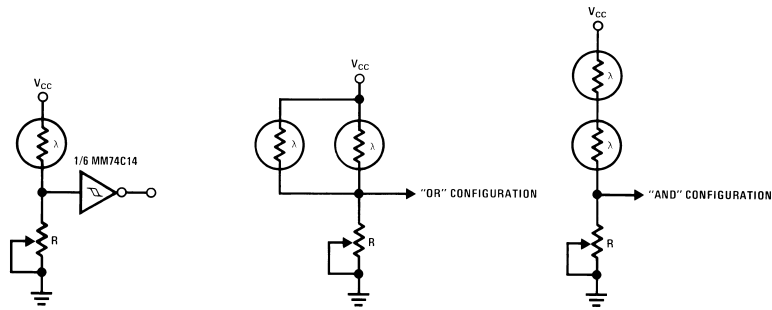

AN006024-8

**FIGURE 7. Light activated switch couldn't be simpler. The input voltage rises as light intensity increases, when  $V_{T+}$  is reached, the output will go low and remain low until the intensity is reduced significantly.**

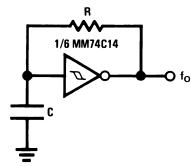

AN006024-9

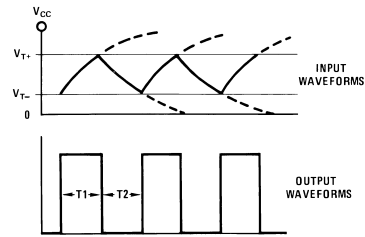

AN006024-10

$$f_o = \frac{1}{RC \ln \left[ \left( \frac{V_{CC} - V_{T-}}{V_{CC} - V_{T+}} \right) \left( \frac{V_{T+}}{V_{T-}} \right) \right]}$$

**FIGURE 8. Simplest RC Oscillator? Six R's and C's make the CMOS Schmitt into six low power oscillators. Balanced input and output characteristics give the output frequency a typically 50% Duty Cycle.**

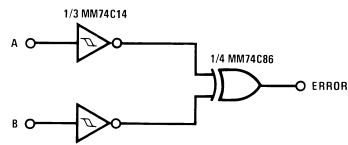

AN006024-11

$$\bar{A} B + A \bar{B} = \text{Error}$$

Error is detected when transmission line is unbalanced in either direction.

a) Differential Error Detector

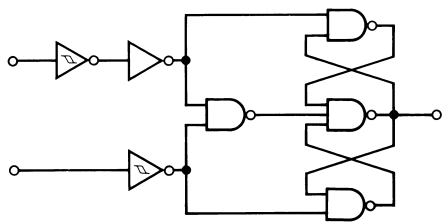

AN006024-12

Transmitted data appears at F as long as transmission line is balanced, unbalanced data is ignored and error is detected by above circuit.

b) Differential Line Receiver

## Truth Table

A	B	F
0	0	NC
0	1	0
1	0	1
1	1	NC

NC = No Change

1/3 MM74C14 Schmitt Trigger

1/6 MM74C04 Inverter

3/4 MM74C00 2-Input NAND

1/3 MM74C10 3-Input NAND

**FIGURE 9. Increase noise immunity by using the CMOS Schmitt trigger to demodulate a balanced transmission line.**

We earlier saw how the CMOS Schmitt increased noise immunity on an unbalanced transmission line. *Figure 9* shows an application for a balanced or differential transmission line. The circuit in *Figure 7 a* is CMOS EXCLUSIVE OR, the MM74C86, which could also be built from inverters, and NAND gates. If unbalanced information is generated on the line by signal crosstalk or external noise sources, it is recognized as an error.

The circuit in *Figure 9b* is a differential line receiver that recovers balanced transmitted data but ignores unbalanced signals by latching up. If both circuits of *Figure 9* were used together, the error detector could signal the transmitter to stop transmission and the line receiver would remember the last valid information bit when unbalanced signals persisted on the line. When balanced signals are restored, the receiver can pick up where it left off.

The standard voltage range for CMOS inputs is  $V_{CC} + 0.3V$  and ground  $- 0.3V$ . This is because the input protection network is diode clamped to the supply rails. Any input exceeding the supply rails either sources or sinks a large amount of current through these diodes. Many times an input voltage range exceeding this is desirable; for example, transmission lines often operate from  $\pm 12V$  and op amps from  $\pm 15V$ . A solution to this problem is found in the MM74C914. This new device has an uncommon input protection that allows the input signal to go to 25V above ground, and 25V below  $V_{CC}$ . This means that the Schmitt trigger in the sine to square wave converter, in *Figure 6b*, could be powered by  $\pm 1.5V$  supplies and still be directly compatible with an op amp powered by  $\pm 15V$  supplies.

A standard input protection circuit and the new input protection are shown in *Figure 10*. The diodes shown have a 35V

breakdown. The input voltage can go positive until reverse biased D2 breaks down through forward bias D3, which is 35V above ground. The input voltage can go negative until reverse biased D1 breaks down through forward bias D2, which is 35V below  $V_{CC}$ . Adequate input protection against static charge is still maintained.

CMOS can be linear over a wide voltage range if proper consideration is paid to the biasing of the inputs. *Figure 11* shows a simple VCO made with a CMOS inverter, acting as an integrator, and a CMOS Schmitt, acting as a comparator with hysteresis. The inverter integrates the positive difference between its threshold and the input voltage  $V_{IN}$ . The inverter output ramps up until the positive threshold of the Schmitt trigger is reached. At that time, the Schmitt trigger output goes low, turning on the transistor through  $R_S$  and speeding up capacitor  $C_S$ . Hysteresis keeps the output low until the integrating capacitor  $C$  is discharged through  $R_D$ . Resistor  $R_D$  should be kept much smaller than  $RC$  to keep reset time negligible. The output frequency is given by

$$f_O = \frac{V_{TH} - V_{IN}}{(V_{T+} - V_{T-})R_{CC}}$$

The frequency dependence with control voltage is given by the derivative with respect to  $V_{in}$ . So,

$$\frac{df_O}{dV_{IN}} = \frac{-1}{(V_{T+} - V_{T-})RC}$$

where the minus sign indicates that the output frequency increases as the input is brought further below the inverter threshold. The maximum output frequency occurs when  $V_{IN}$

is at ground and the frequency will decrease as  $V_{IN}$  is raised up and will finally stop oscillating at the inverter threshold, approximately  $0.55 V_{CC}$ .

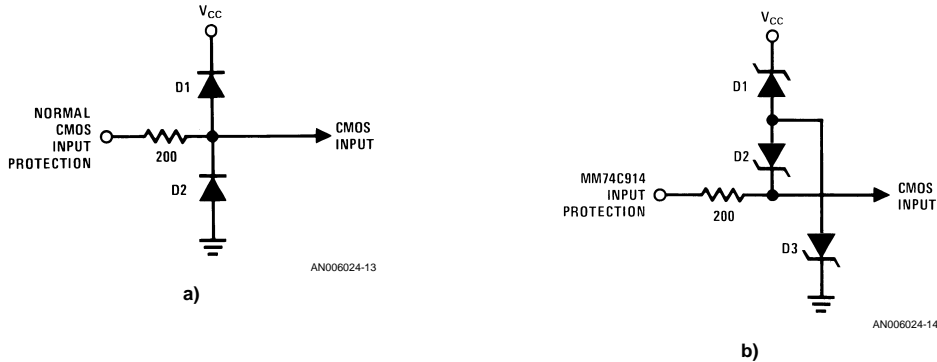
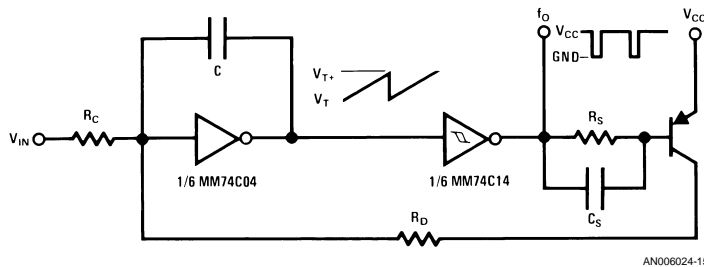

FIGURE 10. Input protection diodes, in a) Normally limit the input voltage swing to 0.3V above  $V_{CC}$  and 0.3V below ground. In b) D2 or D1 is reverse biased allowing input swings of 25V above ground or 25V below  $V_{CC}$ .



$$f_o = \frac{V_{TH} - V_{IN}}{(V_{T+} - V_T) R_C C}$$

$$\frac{df_o}{dV_{IN}} = \frac{-1}{(V_{T+} - V_T) R_C C}$$

$$0 \leq V_{IN} \leq \frac{1}{2} V_{CC}$$

FIGURE 11. Linear CMOS (Voltage Controller Oscillator)

The pulses from the VCO output are quite narrow because the reset time is much smaller than the integration time. Pulse stretching comes quite naturally to a Schmitt trigger. A one-shot or pulse stretcher made with an inverter and Schmitt trigger is shown in Figure 12. A positive pulse coming into the inverter causes its output to go low, discharging the capacitor through the diode D1. The capacitor is rapidly discharged, so the Schmitt input is brought low and the output goes positive. Check the size of the capacitor to make sure that inverter can fully discharge the capacitor in the input pulse time, or

$$I_{SINK\ INVERTER} > \frac{C \Delta V}{\Delta T} + \frac{\Delta V}{R}$$

where  $\Delta V = V_{CC}$  for CMOS, and  $\Delta T$  is the input pulse width. For very narrow pulses, under 100 ns, the capacitor can be omitted and a large resistor will charge up the CMOS gate capacitance just like a capacitor. When the inverter input returns to zero, the blocking diode prevents the inverter from charging the capacitor and the re-

sistor must charge it from its supply. When the input voltage of the Schmitt reaches  $V_{T+}$ , the Schmitt output will go low sometime after the input pulse has gone low.

#### THE SCHMITT SOLUTION

The Schmitt trigger, built from discrete parts, is a careful and sometimes time-consuming design. When introduced in integrated TTL, a few years ago, many circuit designers had renewed interest because it was a building block part. The input characteristics of TTL often make biasing of the trigger input difficult. The outputs don't source as much as they sink, so multivibrators don't have 50% duty cycle, and a limited supply range hampers interfacing with non-5V parts.

The CMOS Schmitt has a very high input impedance with thresholds approximately symmetrical to one half the supply. A high voltage input is available. The outputs sink and source equal currents and pull directly to the supply rails.

A wide threshold range, wide supply range, high noise immunity, low power consumption, and low board space make the CMOS Schmitt a uniquely versatile part.



Use the Schmitt trigger for signal conditioning, restoration of levels, discriminating noisy signals, level detecting with hysteresis, level conversion between logic families, and many other useful functions.

The CMOS Schmitt is one step closer to making design limited only by the imagination of the designer.

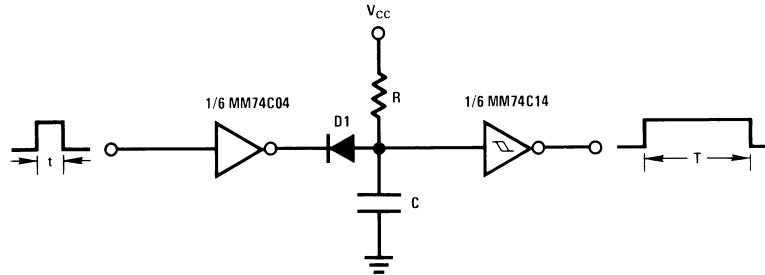

AN006024-16

$$T_O = t_{IN} + T$$

$$T = RC \ln \left( \frac{V_{CC} - V_{BE}}{V_{CC} - V_{T+}} \right) \quad \text{BE SURE THAT } I_{\text{SINK INVERTER}} > \frac{C V_{CC}}{t} + \frac{V_{CC}}{R}$$

**FIGURE 12. Pulse Stretcher. A CMOS inverter discharges a capacitor, a blocking diode allows charging through R only. Schmitt trigger output goes low after the RC delay.**

#### LIFE SUPPORT POLICY

FAIRCHILD'S PRODUCTS ARE NOT AUTHORIZED FOR USE AS CRITICAL COMPONENTS IN LIFE SUPPORT DEVICES OR SYSTEMS WITHOUT THE EXPRESS WRITTEN APPROVAL OF THE PRESIDENT OF FAIRCHILD SEMICONDUCTOR CORPORATION. As used herein:

1. Life support devices or systems are devices or systems which, (a) are intended for surgical implant into the body, or (b) support or sustain life, and (c) whose failure to perform when properly used in accordance with instructions for use provided in the labeling, can be reasonably expected to result in a significant injury to the user.
2. A critical component in any component of a life support device or system whose failure to perform can be reasonably expected to cause the failure of the life support device or system, or to affect its safety or effectiveness.

**Fairchild Semiconductor Corporation Americas**  
Customer Response Center  
Tel: 1-888-522-5372

**Fairchild Semiconductor Europe**  
Fax: +49 (0) 1 80-530 85 86  
Email: europe.support@nsc.com  
Deutsch Tel: +49 (0) 8 141-35-0  
English Tel: +44 (0) 1 793-85-68-56  
Italy Tel: +39 (0) 2 57 5631

**Fairchild Semiconductor Hong Kong Ltd.**  
13th Floor, Straight Block,  
Ocean Centre, 5 Canton Rd.  
Tsimshatsui, Kowloon  
Hong Kong  
Tel: +852 2737-7200  
Fax: +852 2314-0061

**National Semiconductor Japan Ltd.**  
Tel: 81-3-5620-6175  
Fax: 81-3-5620-6179

www.fairchildsemi.com

ON Semiconductor and  are trademarks of Semiconductor Components Industries, LLC dba ON Semiconductor or its subsidiaries in the United States and/or other countries. ON Semiconductor owns the rights to a number of patents, trademarks, copyrights, trade secrets, and other intellectual property. A listing of ON Semiconductor's product/patent coverage may be accessed at [www.onsemi.com/site/pdf/Patent-Marking.pdf](http://www.onsemi.com/site/pdf/Patent-Marking.pdf). ON Semiconductor reserves the right to make changes without further notice to any products herein. ON Semiconductor makes no warranty, representation or guarantee regarding the suitability of its products for any particular purpose, nor does ON Semiconductor assume any liability arising out of the application or use of any product or circuit, and specifically disclaims any and all liability, including without limitation special, consequential or incidental damages. Buyer is responsible for its products and applications using ON Semiconductor products, including compliance with all laws, regulations and safety requirements or standards, regardless of any support or applications information provided by ON Semiconductor. "Typical" parameters which may be provided in ON Semiconductor data sheets and/or specifications can and do vary in different applications and actual performance may vary over time. All operating parameters, including "Typicals" must be validated for each customer application by customer's technical experts. ON Semiconductor does not convey any license under its patent rights nor the rights of others. ON Semiconductor products are not designed, intended, or authorized for use as a critical component in life support systems or any FDA Class 3 medical devices or medical devices with a same or similar classification in a foreign jurisdiction or any devices intended for implantation in the human body. Should Buyer purchase or use ON Semiconductor products for any such unintended or unauthorized application, Buyer shall indemnify and hold ON Semiconductor and its officers, employees, subsidiaries, affiliates, and distributors harmless against all claims, costs, damages, and expenses, and reasonable attorney fees arising out of, directly or indirectly, any claim of personal injury or death associated with such unintended or unauthorized use, even if such claim alleges that ON Semiconductor was negligent regarding the design or manufacture of the part. ON Semiconductor is an Equal Opportunity/Affirmative Action Employer. This literature is subject to all applicable copyright laws and is not for resale in any manner.

## PUBLICATION ORDERING INFORMATION

### LITERATURE FULFILLMENT:

Literature Distribution Center for ON Semiconductor  
19521 E. 32nd Pkwy, Aurora, Colorado 80011 USA  
**Phone:** 303-675-2175 or 800-344-3860 Toll Free USA/Canada  
**Fax:** 303-675-2176 or 800-344-3867 Toll Free USA/Canada  
**Email:** [orderlit@onsemi.com](mailto:orderlit@onsemi.com)

**N. American Technical Support:** 800-282-9855 Toll Free  
USA/Canada  
**Europe, Middle East and Africa Technical Support:**  
Phone: 421 33 790 2910  
**Japan Customer Focus Center**  
Phone: 81-3-5817-1050

**ON Semiconductor Website:** [www.onsemi.com](http://www.onsemi.com)  
**Order Literature:** <http://www.onsemi.com/orderlit>  
For additional information, please contact your local  
Sales Representative