

NCP1308

Controller, Free Running Quasi-Resonant Current Mode

The NCP1308 combines a true current mode modulator and a demagnetization detector to ensure full borderline/Critical Conduction Mode in any load/line conditions and minimum drain voltage switching (Quasi-Resonant operation). Due to its inherent skip cycle capability, the controller enters burst mode as soon as the power demand falls below a predetermined level. As this happens at low peak current, no audible noise can be heard. An internal 10 μ s timer prevents the free-run frequency to exceed a high frequency (therefore below the 150 kHz CISPR-22 EMI starting limit), while the skip adjustment capability lets the user select the frequency at which the burst foldback takes place.

The Dynamic Self-Supply (DSS) drastically simplifies the transformer design in avoiding the use of an auxiliary winding to supply the NCP1308. This feature is particularly useful in applications where the output voltage varies during operation (e.g. battery chargers). Thanks to its high-voltage technology, the IC is directly connected to the high-voltage DC rail. As a result, the short-circuit trip point is not dependent upon any V_{CC} auxiliary level.

The transformer core reset detection is done through an auxiliary winding which, brought via a dedicated pin. If an OVP is detected on the V_{CC} pin, the IC permanently latches off.

Finally, the continuous feedback signal monitoring implemented with an Overcurrent fault Protection circuitry (OCP) makes the final design rugged and reliable.

Features

- Free-Running Borderline/Critical Mode Quasi-Resonant Operation
- Current-Mode with Adjustable Skip Cycle Capability
- Dynamic Self-Supply Type of V_{CC}
- Auto-Recovery Overcurrent Protection
- Improved UVLO for V_{CC} below 10 V
- Latching Overvoltage Protection on V_{CC}
- 500 mA Peak Current Source/Sink Capability
- Internal 1.0 ms Soft-Start
- Internal 10 μ s Minimum T_{OFF}
- Adjustable Skip Level
- Internal Temperature Shutdown
- Internal Leading Edge Blanking
- Direct Optocoupler Connection
- SPICE Models Available for TRANSient Analysis
- This is a Pb-Free Device

Typical Applications

- AC-DC Adapters for Notebooks, etc.
- Offline Battery Chargers
- Consumer Electronics (DVD Players, Set-Top Boxes, TVs, etc.)
- Auxiliary Power Supplies (USB, Appliances, TVs, etc.)



ON Semiconductor®

<http://onsemi.com>

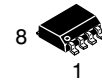

SOIC-8
D SUFFIX
CASE 751

MARKING DIAGRAM

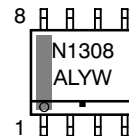

A = Assembly Location
L = Wafer Lot
Y = Year
W = Work Week
▪ = Pb-Free Package

PIN CONNECTIONS

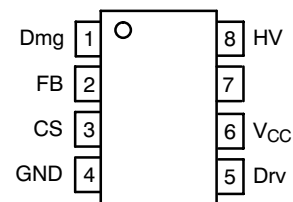

(Top View)

ORDERING INFORMATION

Device	Package	Shipping†
NCP1308DR2G	SOIC-8 (Pb-Free)	2500/Tape & Reel

†For information on tape and reel specifications, including part orientation and tape sizes, please refer to our Tape and Reel Packaging Specifications Brochure, BRD8011/D.

NCP1308

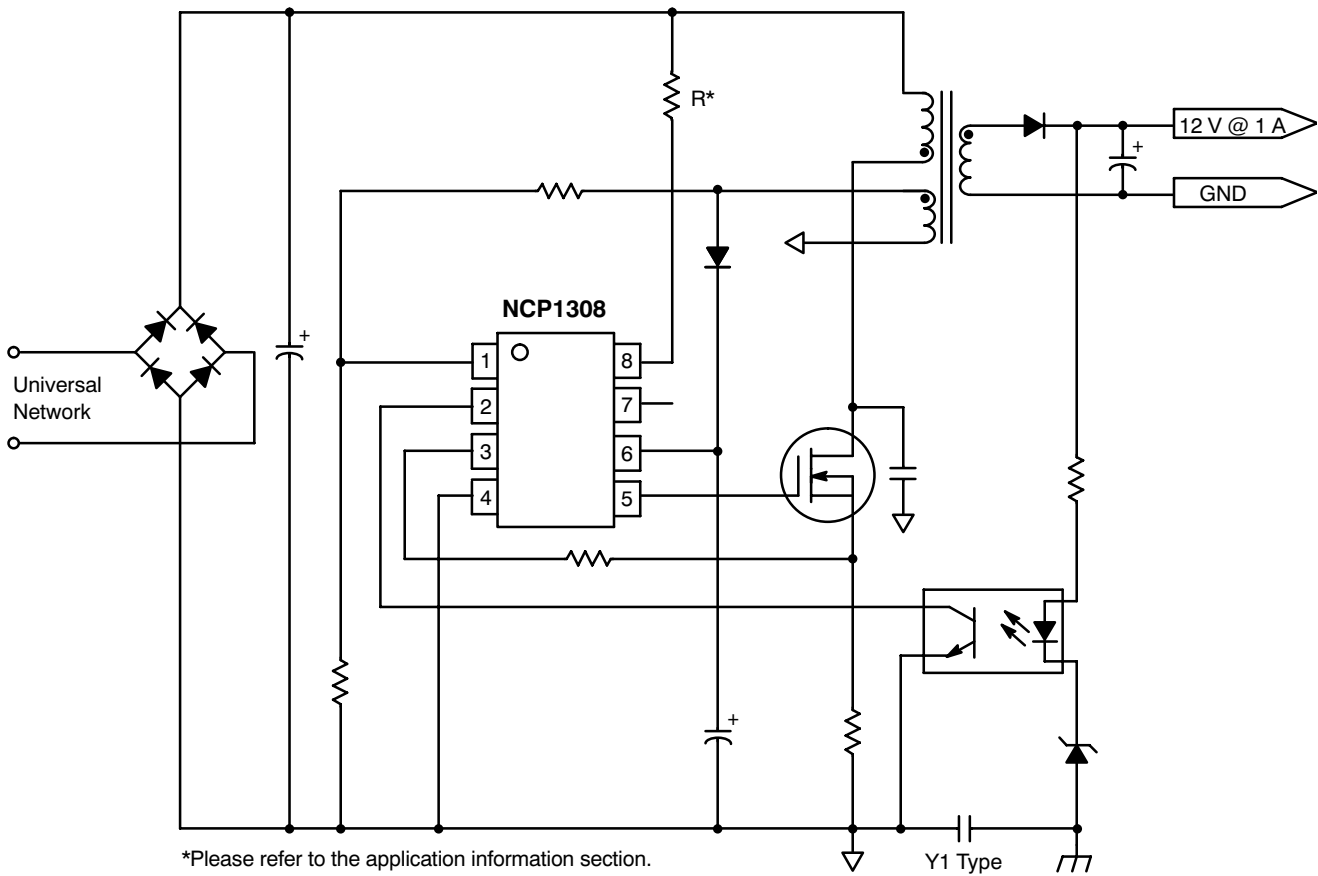

Figure 1. Typical Application Schematic

PIN FUNCTION DESCRIPTION

Pin	Symbol	Function	Description
1	Dmg	Core reset detection	The auxiliary FLYBACK signal ensures discontinuous operation.
2	FB	Sets the peak current setpoint	By connecting an optocoupler to this pin, the peak current setpoint is adjusted accordingly to the output power demand. By bringing this pin below the internal skip level, the device shuts off.
3	CS	Current sense input and skip cycle level selection	This pin senses the primary current and routes it to the internal comparator via an LEB. By inserting a resistor in series with the pin, you control the level at which the skip operation takes place.
4	GND	The IC ground	-
5	Drv	Driving pulses	The driver's output to an external MOSFET.
6	V _{CC}	Supplies the IC	This pin is connected to an external bulk capacitor of typically 10 μF. If an auxiliary winding brings this pin above 16 V typical, the circuit permanently latches off.
7	NC	-	This unconnected pin ensures adequate creepage distance.
8	HV	High-voltage pin	Connected to the high-voltage rail, this pin injects a constant current into the V _{CC} bulk capacitor.

NCP1308

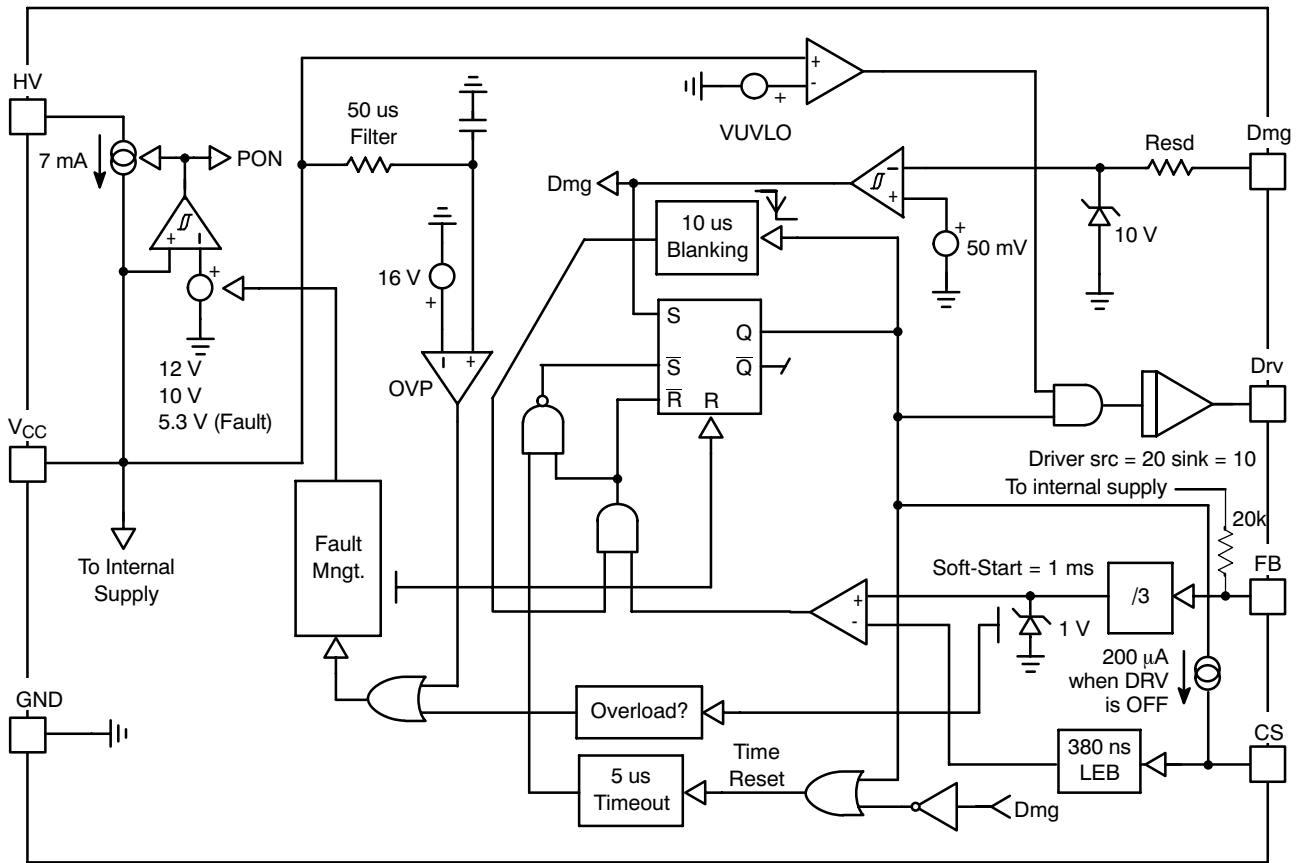

Figure 2. Internal Circuit Architecture

MAXIMUM RATINGS

Rating	Symbol	Value	Unit
Power Supply Voltage	V_{CC} , Drv	20	V
Maximum Voltage on all other pins except Pin 8 (HV), Pin 6 (V_{CC}) and Pin 5 (Drv) and Pin 1 (Dmg)	-	-0.3 to 10	V
Maximum Current into all pins except V_{CC} (6), HV (8) and Dmg (1) when 10 V ESD diodes are activated	-	5.0	mA
Maximum Current in Pin 1	Idem	+3.0/-2.0	mA
Thermal Resistance, Junction-to-Case	$R_{\theta JC}$	57	$^{\circ}C/W$
Thermal Resistance, Junction-to-Air	$R_{\theta JA}$	178	$^{\circ}C/W$
Maximum Junction Temperature	T_{JMAX}	150	$^{\circ}C$
Temperature Shutdown	-	155	$^{\circ}C$
Hysteresis in Shutdown	-	30	$^{\circ}C$
Storage Temperature Range	-	-60 to +150	$^{\circ}C$
ESD Capability, Human Body Model (All pins except HV)	-	2.0	kV
ESD Capability, Machine Model	-	200	V
Maximum Voltage on Pin 8 (HV), Pin 6 (V_{CC}) Decoupled to Ground with 10 μF	V_{HVMAX}	500	V
Minimum Voltage on Pin 8 (HV), Pin 6 (V_{CC}) Decoupled to Ground with 10 μF	V_{HVMIN}	40	V

Stresses exceeding Maximum Ratings may damage the device. Maximum Ratings are stress ratings only. Functional operation above the Recommended Operating Conditions is not implied. Extended exposure to stresses above the Recommended Operating Conditions may affect device reliability.

NCP1308

ELECTRICAL CHARACTERISTICS (For typical values $T_J = 25^\circ\text{C}$, for min/max values $T_J = 0^\circ\text{C}$ to $+125^\circ\text{C}$, Max $T_J = 150^\circ\text{C}$, $V_{CC} = 11\text{ V}$ unless otherwise noted.)

Characteristic	Pin	Symbol	Min	Typ	Max	Unit
----------------	-----	--------	-----	-----	-----	------

DYNAMIC SELF SUPPLY

V_{CC} Increasing Level at which the Current Source Turns-Off	6	V_{CCOFF}	10.8	12	12.9	V
V_{CC} Decreasing Level at which the Current Source Turns-On	6	V_{CCON}	9.1	10	10.6	V
V_{CC} Decreasing Level at which the Latchoff Phase Ends	6	$V_{CClatch}$	-	5.3	-	V
V_{CC} Level at which pulses are disabled	6	VUVLO	-	$V_{CCON} - 200\text{ mV}$	-	V
Internal IC Consumption, No Output Load on Pin 5, $F_{SW} = 60\text{ kHz}$	6	ICC1	-	1.0	1.3 (Note 1)	mA
Internal IC Consumption, 1.0 nF Output Load on Pin 5, $F_{SW} = 60\text{ kHz}$	6	ICC2	-	1.6	2.0 (Note 1)	mA
Internal IC Consumption, Latchoff Phase, $V_{CC} = 6.0\text{ V}$	6	ICC3	-	330	-	μA

INTERNAL STARTUP CURRENT SOURCE ($T_J = 0^\circ\text{C}$)

High-Voltage Current Source, $V_{CC} = 10\text{ V}$	8	IC1	4.3	7.0	9.6	mA
High-Voltage Current Source, $V_{CC} = 0$	8	IC2	-	8.0	-	mA

DRIVE OUTPUT

Output Voltage Rise-Time @ $CL = 1.0\text{ nF}$, 10-90% of Output Signal	5	T_r	-	40	-	ns
Output Voltage Fall-Time @ $CL = 1.0\text{ nF}$, 10-90% of Output Signal	5	T_f	-	20	-	ns
Source Resistance	5	R_{OH}	12	20	36	Ω
Sink Resistance	5	R_{OL}	5.0	10	20	Ω

CURRENT COMPARATOR

Input Bias Current @ 1.0 V Input Level on Pin 3	3	I_{IB}	-	0.02	-	μA
Maximum Internal Current Setpoint	3	I_{Limit}	0.92	1.0	1.12	V
Propagation Delay from Current Detection to Gate OFF State	3	T_{DEL}	-	100	160	ns
Leading Edge Blanking Duration	3	T_{LEB}	-	380	-	ns
Internal Current Offset Injected on the CS Pin During OFF Time	3	I_{skip}	-	200	-	μA

OVERVOLTAGE SECTION

Voltage on the V_{CC} above which the controller latches off	6	VOVP	14.3	16	17.8	V
Integration Time Constraint on the OVP comparator	6	T_{int}	-	50	-	μs

FEEDBACK SECTION ($V_{CC} = 11\text{ V}$, Pin 5 loaded by 1.0 k Ω)

Internal Pullup Resistor	2	R_{up}	-	20	-	k Ω
Pin 3 to Current Setpoint Division Ratio	-	I_{ratio}	-	3.3	-	-
Internal Soft-Start	-	T_{ss}	-	1.0	-	ms

DEMAGNETIZATION DETECTION BLOCK

Input Threshold Voltage (Vpin 1 Decreasing)	1	V_{th}	35	50	90	mV
Hysteresis (Vpin 1 Decreasing)	1	V_H	-	20	-	mV
Input Clamp Voltage						V
High State ($I_{pin 1} = 3.0\text{ mA}$)	1	V_{CH}	8.0	10	12	
Low State ($I_{pin 1} = -2.0\text{ mA}$)	1	V_{CL}	-0.9	-0.7	-0.5	
Dmg Propagation Delay	1	T_{dem}	-	210	-	ns
Internal Input Capacitance at Vpin 1 = 1.0 V	1	C_{par}	-	10	-	pF
Minimum T_{OFF} (Internal Blanking Delay After T_{ON})	1	T_{blank}	-	10	-	μs
Timeout After Last Dmg Transition	1	T_{out}	-	5.0	-	μs

1. Max value at $T_J = 0^\circ\text{C}$, please see characterization curves.

NCP1308

TYPICAL CHARACTERISTICS

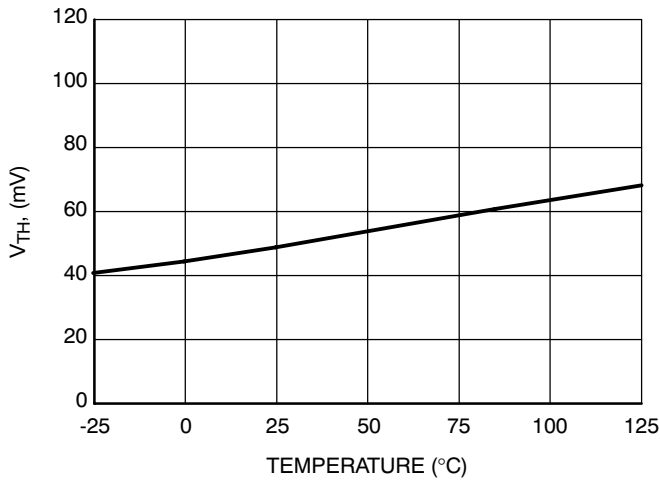

Figure 3. Demagnetization Threshold vs. Temperature

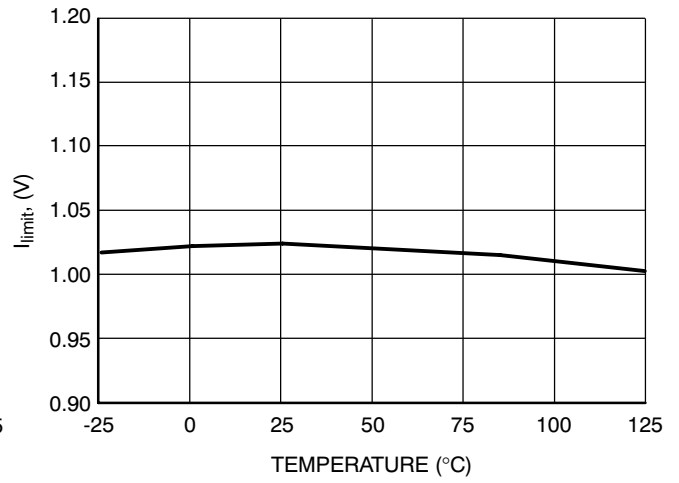

Figure 4. Maximum Peak Current Setpoint vs. Temperature

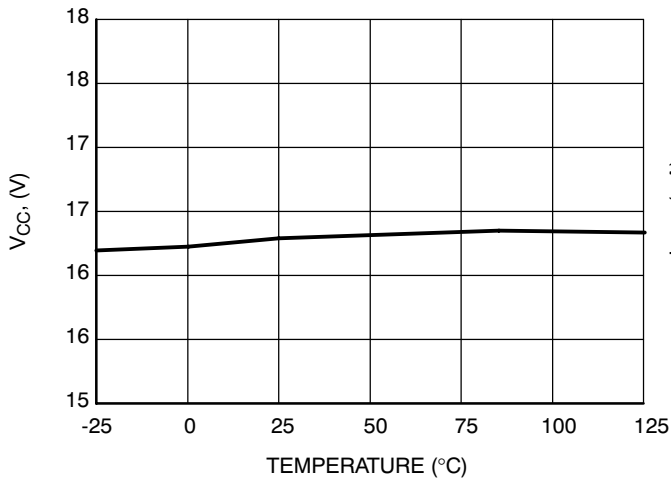

Figure 5. OVP Level Threshold vs. Temperature

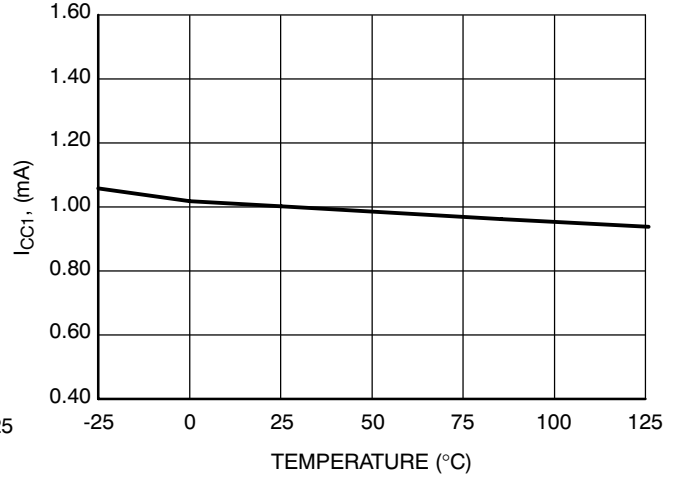

Figure 6. Internal IC Consumption (No Output Load) vs. Temperature

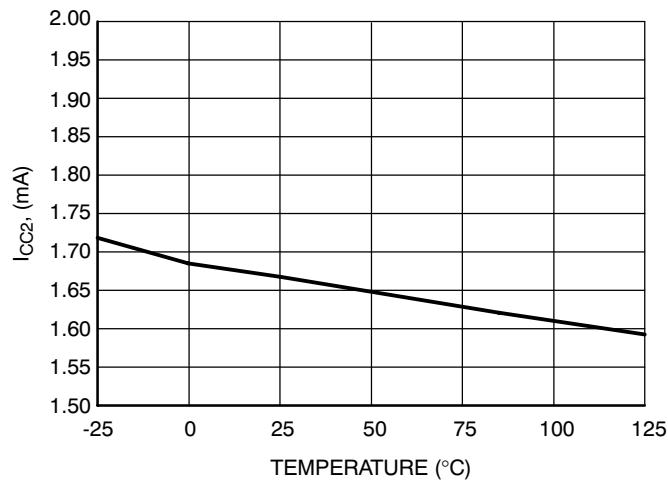

Figure 7. Internal IC Consumption (1.0 nF Load) vs. Temperature

NCP1308

TYPICAL CHARACTERISTICS

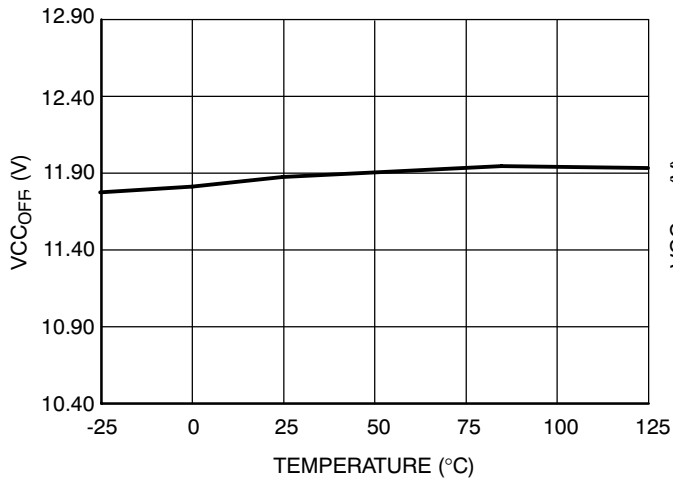

Figure 8. V_{CC} Increasing Level at which the Current Source Turns-off vs. Temperature

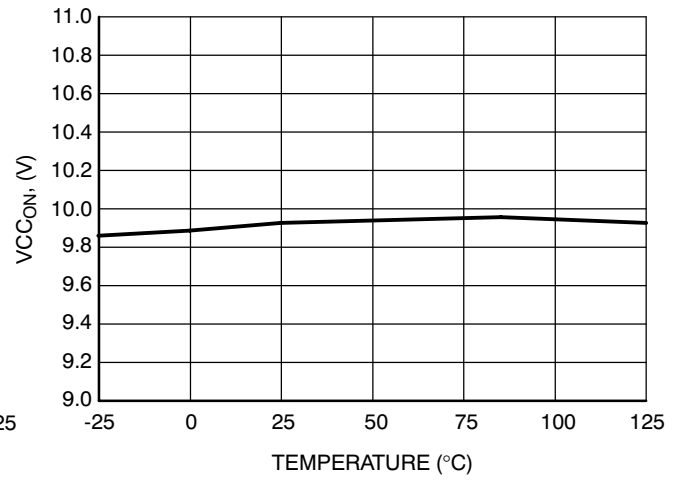

Figure 9. V_{CC} Decreasing Level at which the Current Source Turns-on vs. Temperature

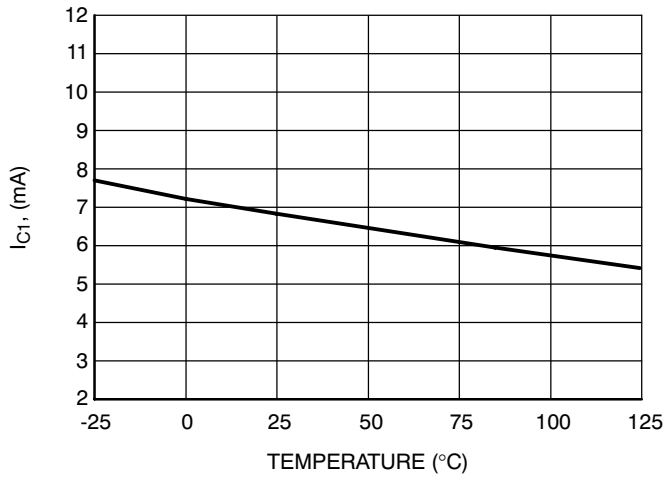

Figure 10. Internal Startup Current Source, V_{CC} = 10 V vs. Temperature

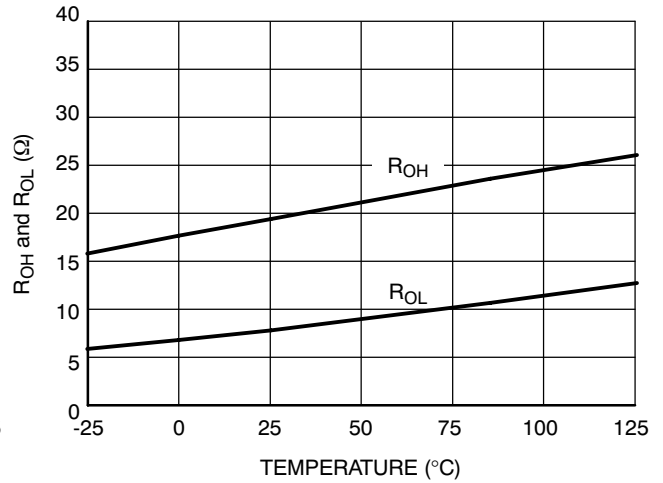

Figure 11. Source and Sink Resistance vs. Temperature

APPLICATION INFORMATION

INTRODUCTION

The NCP1308 implements a standard current mode architecture where the switch-off time is dictated by the peak current setpoint, whereas the core reset detection triggers the turn-on event. This component represents the ideal candidate where low part-count is the key parameter, particularly in low-cost AC/DC adapters, consumer electronics, auxiliary supplies, etc. Due to its high-performance High-Voltage technology, the NCP1308 incorporates all the necessary components/features needed to build a rugged and reliable Switch-Mode Power Supply (SMPS):

- **Transformer Core Reset Detection:** Borderline/critical operation is ensured whatever the operating conditions are. As a result, there are virtually no primary switch turn-on losses and no secondary diode recovery losses. The converter also stays a first-order system and accordingly eases the feedback loop design.
- **Quasi-Resonant Operation:** By delaying the turn-on event, it is possible to restart the MOSFET in the minimum of the drain-source wave, ensuring reduced EMI/video noise perturbations. In nominal power conditions, the NCP1308 operates in Borderline Conduction Mode (BCM) also called Critical Conduction Mode (CCM).
- **Dynamic Self-Supply (DSS):** Due to its Very High Voltage Integrated Circuit (VHVIC) technology, ON Semiconductor's NCP1308 allows for a direct pin connection to the high-voltage DC rail. A dynamic current source charges up a capacitor and thus provides a fully independent V_{CC} level to the NCP1308. As a result, there is no need for an auxiliary winding to supply the IC, whose management is always a problem in variable output voltage designs (e.g. battery chargers).
- **Overvoltage Protection (OVP):** By monitoring the V_{CC} pin via a 50 μ s time constant filter, the NCP1308 goes into latched fault condition whenever an overvoltage condition is detected. This occurs if V_{CC} goes above 16 V typically. The controller stays fully latched in this position until the V_{CC} is cycled down to 4 V, e.g. when the user unplugs the power supply from the mains outlet and re-plugs it.
- **Adjustable Skip Cycle Level:** By offering the ability to tailor the level at which the skip cycle takes place, the designer can make sure that the skip operation only occurs at low peak current. This point guarantees

a noise-free operation with cheap transformer. This option also offers the ability to fix the maximum switching frequency when entering light load conditions.

- **Overcurrent Protection (OCP):** By continuously monitoring the FB line activity, NCP1308 enters burst mode as soon as the power supply undergoes an overload. The device enters a safe low power operation that prevents from any lethal thermal runaway. As soon as the default disappears, the power supply resumes operation. Unlike other controllers, overload detection is performed independently of any auxiliary winding level. In presence of a bad coupling between both power and auxiliary windings, the short circuit detection can be severely affected. The DSS naturally shields you against these troubles.

Dynamic Self-Supply

The DSS principle is based on the charge/discharge of the V_{CC} bulk capacitor from a low level up to a higher level. We can easily describe the current source operation with some simple logical equations:

POWER-ON: IF $V_{CC} < V_{CCOFF}$ THEN Current Source is ON, no output pulses

IF V_{CC} decreasing $> V_{CCON}$ THEN Current Source is OFF, output is pulsing

IF V_{CC} increasing $< V_{CCOFF}$ THEN Current Source is ON, output is pulsing

Typical values are: $V_{CCOFF} = 12$ V, $V_{CCON} = 10$ V

To better understand the operational principle, the diagram in Figure 12 offers the necessary light:

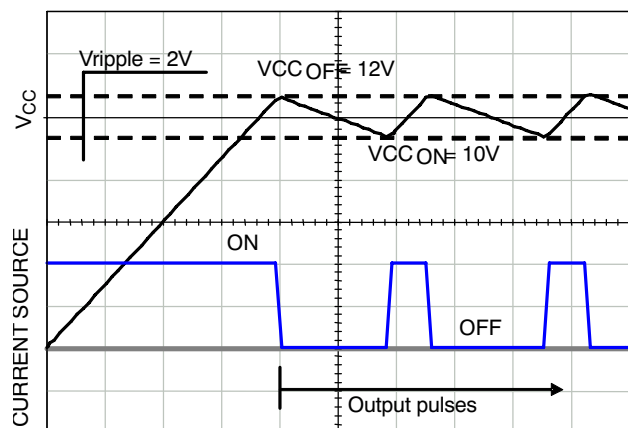

Figure 12. The Charge/Discharge Cycle over a 10 μ F V_{CC} Capacitor

The DSS behavior actually depends on the internal IC consumption and the MOSFET's gate charge Q_g . If we select a MOSFET like the MTP2N60E, Q_g equals 22 nC (max). With a maximum switching frequency selected at 75 kHz, the average power necessary to drive the MOSFET (excluding the driver efficiency and neglecting various voltage drops) is: $F_{SW} \cdot Q_g \cdot V_{CC}$ with:

- F_{SW} = maximum switching frequency
- Q_g = MOSFET's gate charge
- V_{CC} = V_{GS} level applied to the gate

To obtain the output current, simply divide this result by V_{CC} : $I_{driver} = F_{SW} \cdot Q_g = 1.6$ mA. The total standby power consumption at no-load will therefore heavily rely on the internal IC consumption plus the above driving current (altered by the driver's efficiency). Suppose that the IC is supplied from a 350 VDC line. The current flowing through Pin 8 is a direct image of the NCP1308 consumption (neglecting the switching losses of the HV current source). If I_{CC2} equals 2.3 mA @ $T_J = 60^\circ\text{C}$, then the power dissipated (lost) by the IC is simply: $350\text{ V} \times 2.3\text{ mA} = 805\text{ mW}$. For design and reliability reasons, it would be interesting to reduce this source of wasted power that increases the die temperature. This can be achieved by using different methods:

1. Use a MOSFET with lower gate charge Q_g
2. Connect a diode to the half-wave portion to directly supply the HV pin:

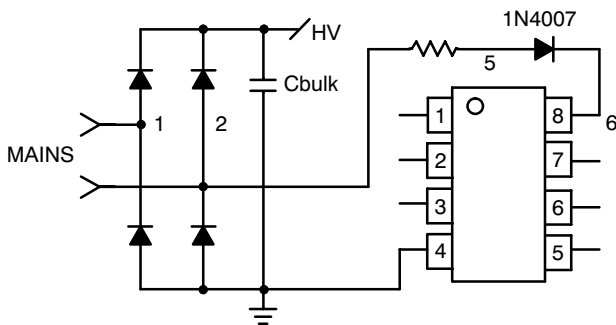

Figure 13. The Connection to the Half-Wave Signal Reduces the Dissipated Power on the Controller

3. Permanently force the V_{CC} level above V_{CCON} with an auxiliary winding. It will automatically disconnect the internal startup source and the IC will be fully self-supplied from this winding. Again, the total power drawn from the mains will significantly decrease. Make sure the auxiliary voltage never exceeds the 16 V limit. When the power supply is switched off, an internal comparator makes sure that all output pulses are disable when V_{CC} crosses V_{CCON} .

Skipping Cycle Mode

The NCP1308 automatically skips switching cycles when the output power demand drops below a given level. This is accomplished by monitoring the FB pin. In normal operation, Pin 2 imposes a peak current accordingly to the load value. If the load demand decreases, the internal loop asks for less peak current. When this setpoint reaches a determined level, the IC prevents the current from decreasing further down and starts to blank the output pulses: the IC enters the so-called skip cycle mode, also named controlled burst operation. The power transfer now depends upon the width of the pulse bunches (Figure 14) and follows the following formula:

$$\frac{1}{2} \cdot L_p \cdot I_p^2 \cdot F_{SW} \cdot D_{burst}$$

- L_p = primary inductance
- F_{SW} = switching frequency within the burst
- I_p = peak current at which skip cycle occurs
- D_{burst} = burst width/burst recurrence

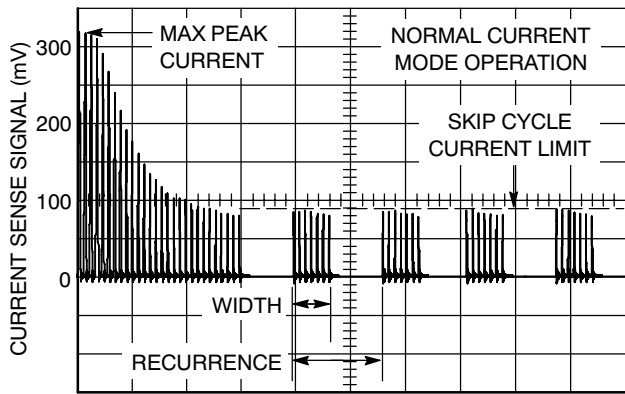

Figure 14. The Skip Cycle Takes Place at Low Peak Currents which Guarantees Noise-Free Operation

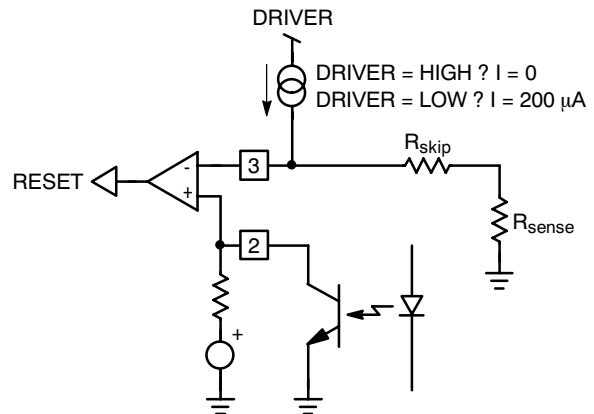

Figure 15. A Patented Method Allows for Skip Level Selection via a Series Resistor Inserted in Series with the Current

The skip level selection is done through a simple resistor inserted between the current sense input and the sense element. Every time the NCP1308 output driver goes low, a 200 μA source forces a current to flow through the sense pin (Figure 15): when the driver is high, the current source is off and the current sense information is normally processed. As soon as the driver goes low, the current source delivers 200 μA and develops a ground-referenced voltage across R_{skip} . If this voltage is below the feedback voltage, the current sense comparator stays in the high state and the internal latch can be triggered by the next clock cycle. Now, if because of a low load mode the feedback voltage is below R_{skip} level, then the current sense comparator permanently resets the latch and the next clock cycle (given by the demagnetization detection) is ignored: we are skipping cycles as shown in Figure 15. As soon as the feedback voltage goes up again, there can be two situations: the recurrent period is small and a new demagnetization detection (next wave) signal triggers the NCP1308. To the opposite, in low output power conditions, no more ringing waves are present on the drain and the toggling of the current sense comparator together with the

internal 5 μs timeout initiates a new cycle start. In normal operating conditions, e.g. when the drain oscillations are generous, the demagnetization comparator can detect the 50 mV crossing and gives the “green light”, alone, to re-active the power switch. However, when skip cycle takes place (e.g. at low output power demands), the restart event slides along the drain ringing waveforms (actually the valley locations) which decays more or less quickly, depending on the $L_{\text{primary}}\text{-}C_{\text{parasitic}}$ network damping factor. The situation can thus quickly occur where the ringing becomes too weak to be detected by the demagnetization comparator: it then permanently stays locked in a given position and can no longer deliver the “green light” to the controller. To help in this situation, the NCP1308 implements a 5 μs timeout generator: each time the 50 mV crossing occurs, the timeout is reset. So, as long as the ringing becomes too low, the timeout generator starts to count and after 5 μs , it delivers its “green light”. If the skip signal is already present then the controller restarts; otherwise the logic waits for it to set the drive output high. Figure 16 depicts these two different situations:

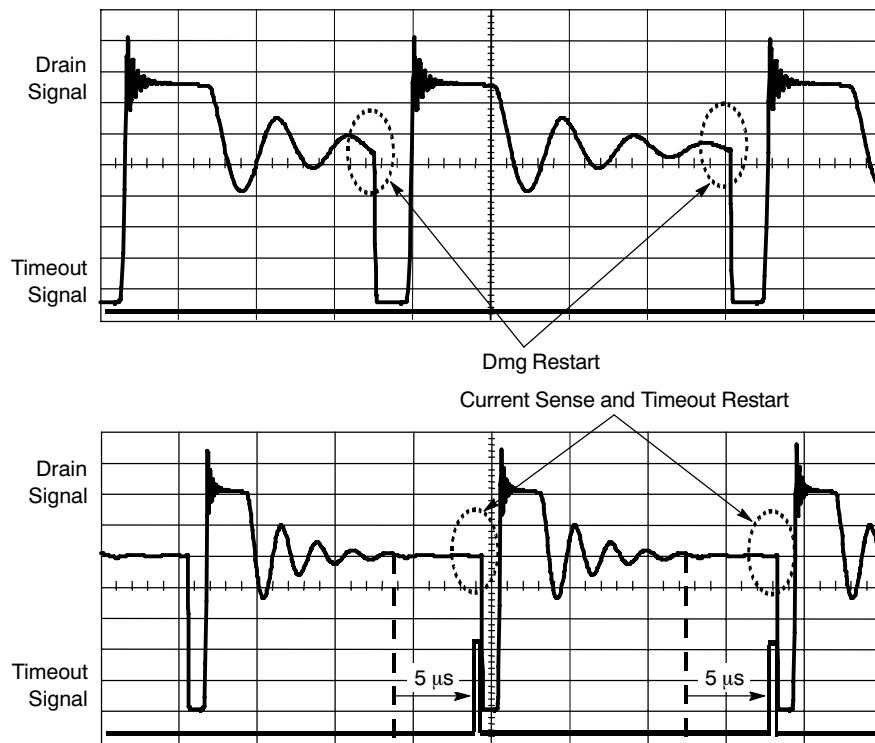

Figure 16. When the primary natural ringing becomes too low, the internal Timeout together with the sense comparator initiates a new cycle when FB passes the skip level.

Demagnetization Detection

The core reset detection is done by monitoring the voltage activity on the auxiliary winding. This voltage features a FLYBACK polarity. The typical detection level is fixed at 50 mV as exemplified by Figure 17.

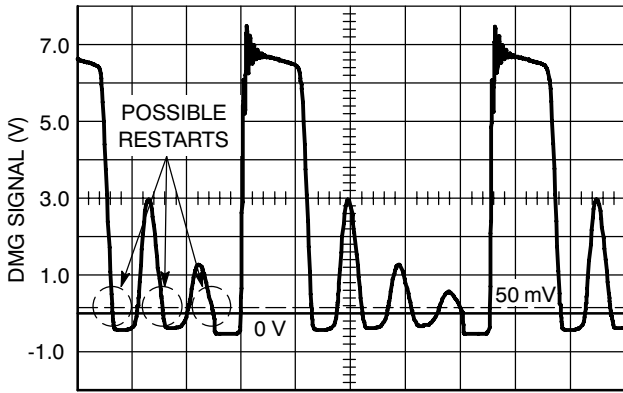

Figure 17. Core Reset Detection is Done through a Dedicated Auxiliary Winding Monitoring

An internal timer prevents any restart within 10 μ s further to the driver going-low transition. This prevents the switching frequency to exceed $(1/(T_{ON} + 10 \mu s))$ but also avoid false leakage inductance tripping at turn-off. In some cases, the leakage inductance kick is so energetic, that a slight filtering is necessary.

The NCP1308 demagnetization detection pad features a specific component arrangement as detailed by Figure 18. In this picture, the Zener diodes network protect the IC against any potential ESD discharge that could appear on the pins. The first ESD diode connected to the pad, exhibits a parasitic capacitance (10 pF typically) is combined with R_{dem} , a restart delay is created and the possibility to switch right in the drain-source wave exists. This guarantees QR operation with all the associated benefits (low EMI, no turn-on losses etc.). R_{dem} should be calculated to limit the maximum current flowing through Pin 1 to less than +3 mA / -2 mA: if during turn-on, the auxiliary winding delivers -30 V (at the highest line level), then the minimum R_{dem} value is defined by: $(-30 + 0.7)$. This value will be further increased to introduce a restart delay and also a slight filtering in case of high leakage energy.

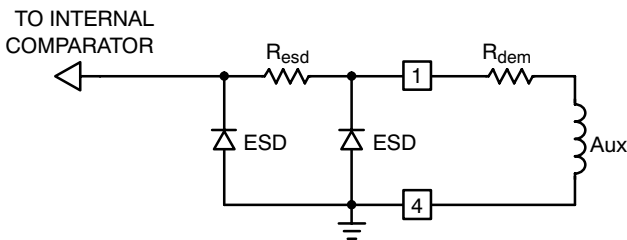

Figure 18. Internal Pad Implementation

Figure 19 portrays a typical V_{ds} shot at nominal output power.

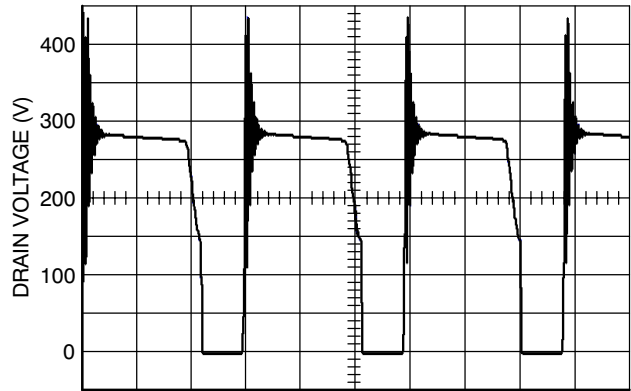

Figure 19. The NCP1308 Operates in Borderline/Critical Operation

Overvoltage Protection

The overvoltage works by monitoring the V_{CC} pin via a comparator and a reference voltage. Figure 20 portrays the internal arrangement:

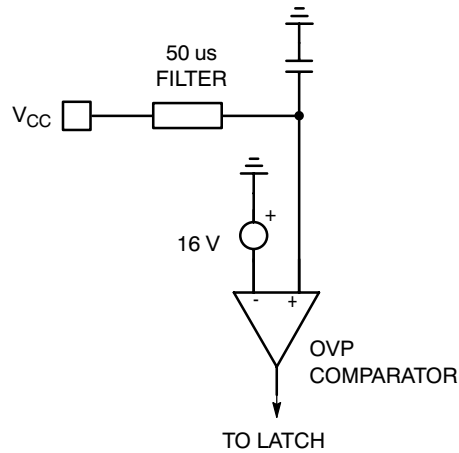

Figure 20. OVP Section Circuitry

A 50 μ s time-constant filter prevents any parasitic spikes superimposed on the V_{CC} to adversely trigger the OVP comparator. When the OVP comparator output goes high, the NCP1308 fully latches off and stays latched, being self-supplied by the DSS. The user must unplug the power supply and wait that the V_{CC} comes down below a reset voltage of typically 4 V.

Shutting off the NCP1308

Shutdown can easily be implemented through a simple NPN bipolar transistor as depicted by Figure 21. When OFF, Q1 is transparent to the operation. When forward biased, the transistor pulls the FB pin to ground ($V_{CEsat} \approx 200\text{ mV}$) and permanently disables the IC. A small time constant on the transistor base will avoid false triggering

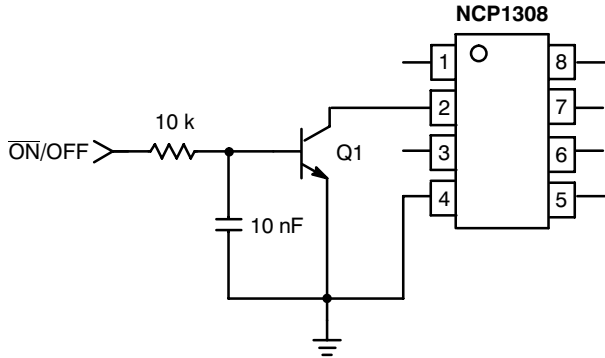

Figure 21. A Simple Bipolar Transistor Totally Disables the IC

Power Dissipation

The SOIC package offers a 178°C/W thermal resistor. Again, adding some copper area around the PCB footprint will help decreasing this number: 12 mm x 12 mm to drop $R_{\theta JA}$ down to 100°C/W with 35 μm copper thickness (1 oz) or 6.5 mm x 6.5 mm with 70 μm copper thickness (2 oz). As one can see, the designer must be cautious when using the SO-8 package to check if its thermal performance is compatible with the total power dissipation. The power dissipation is simply V_{bulk} (high line) x $I_{DSS,AVG}$. The $I_{DSS,AVG}$ parameter can be measured by inserting an amp-meter in series with the HV pin and compute its average value.

We therefore recommend the insertion of a resistor from the bulk connection to the HV pin. This will help to:

1. Avoid negative spikes at turn-off on the HV pin (see below)
2. Split the power budget between this resistor and the package. The resistor is calculated by leaving at least 50 V on pin 8 at minimum input voltage (suppose 100 Vdc in our case):

$$R_{drop} \leq \frac{V_{bulkmin} - 50\text{ V}}{7.0\text{ mA}} < 7.1\text{ k}\Omega .$$

The power dissipated by the resistor is thus:

$$\begin{aligned} P_{drop} &= \frac{V_{dropRMS}^2}{R_{drop}} \\ &= \frac{(I_{DSS} \cdot R_{drop} \cdot \sqrt{DSS_{duty-cycle}})^2}{R_{drop}} \\ &= \frac{(7.0\text{ mA} \cdot 7.1\text{ k}\Omega \cdot \sqrt{0.286})^2}{7.1\text{ k}\Omega} \\ &= 99.5\text{ mW} \end{aligned}$$

where I_{DSS} is the peak DSS capability, $DSS_{duty-cycle}$ is the duty-cycle of the DSS, that is to say, the time it is *on* and the time it stays *off* ($DSS_{duty-cycle} = \text{on}/(\text{on} + \text{off})$).

Please refer to the application note AND8069/D available at www.onsemi.com/pub/ncp1200.

If the power consumption budget is really too high for the DSS alone, connect a diode between the auxiliary winding and the V_{CC} pin which will disable the DSS operation ($V_{CC} > 10\text{ V}$).

Overload Operation

In applications where the output current is purposely not controlled (e.g. wall adapters delivering raw DC level), it is interesting to implement a true short-circuit protection. A short-circuit actually forces the output voltage to be at a low level, preventing a bias current to circulate in the optocoupler LED. As a result, the FB pin level is pulled up to 4.2 V, as internally imposed by the IC. The peak current setpoint goes to the maximum and the supply delivers a rather high power with all the associated effects. Please note that this can also happen in case of feedback loss, e.g. a broken optocoupler. To account for this situation, NCP1308 hosts a dedicated overload detection circuitry. Once activated, this circuitry imposes to deliver pulses in a burst manner with a low duty-cycle. The system recovers when the fault condition disappears.

During the startup phase, the peak current is pushed to the maximum until the output voltage reaches its target and the feedback loop takes over. This period of time depends on normal output load conditions and the maximum peak current allowed by the system. The timeout used by this IC works with the V_{CC} decoupling capacitor: as soon as the V_{CC} decreases from the V_{CCOFF} level (typically 12 V) the device internally watches for an overload current situation. If this condition is still present when the V_{CCON} level is reached, the controller stops the driving pulses, prevents the self-supply current source to restart and puts all the circuitry in standby, consuming as little as 330 μA typical (ICC3 parameter). As a result, the V_{CC} level slowly discharges toward 0. When this level crosses 5.3 V typical, the controller enters a new startup phase by turning the current source on: V_{CC} rises toward 12 V and again delivers output pulses at the V_{CCOFF} crossing point. If the fault condition has been removed before V_{CCON} approaches, then the IC continues its normal operation. Otherwise, a new fault cycle takes place. Figure 22 on the following page shows the evolution of the signals in presence of a fault.

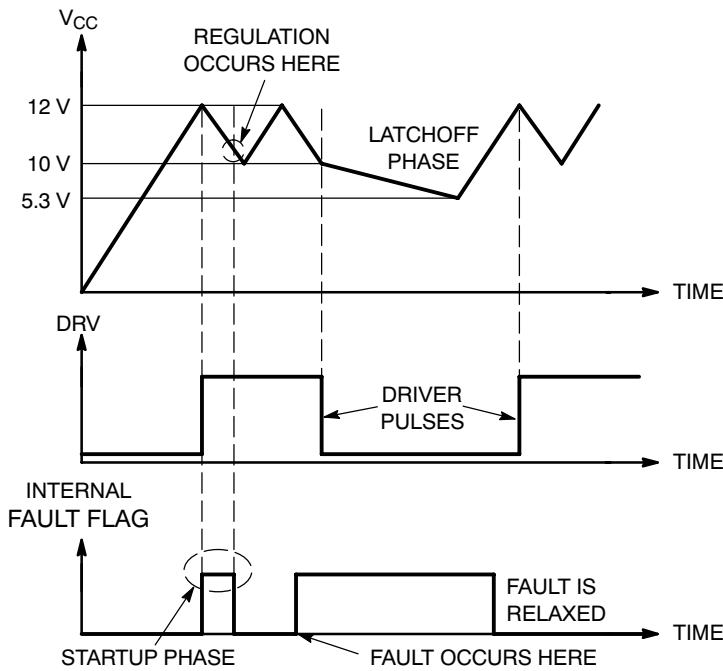

If the fault is relaxed during the V_{CC} natural fall down sequence, the IC automatically resumes. If the fault still persists when V_{CC} reached V_{CCON}, then the controller cuts everything off until recovery.

Figure 22.

Soft-Start

The NCP1308 features an internal 1ms soft-start to soften the constraints occurring in the power supply during startup. It is activated during the power on sequence. As soon as V_{CC} reaches V_{CCOFF}, the peak current is gradually increased from nearly zero up to the maximum clamping level (e.g. 1.0 V). The soft-start is also activated during the over current burst (OCP) sequence. Every restart attempt is followed by a soft-start activation. Generally speaking, the soft-start will be activated when V_{CC} ramps up either from zero (fresh power-on sequence) or 5.3 V, the latchoff voltage occurring during OCP.

Calculating the V_{CC} Capacitor

As the above section describes, the fall down sequence depends upon the V_{CC} level: how long does it take for the V_{CC} line to go from 12 V to 10 V? The required time depends on the startup sequence of your system, i.e. when you first apply the power to the IC. The corresponding transient fault duration due to the output capacitor charging

must be less than the time needed to discharge from 12 V to 10 V, otherwise the supply will not properly start. The test consists in either simulating or measuring in the lab how much time the system takes to reach the regulation at full load. Let's suppose that this time corresponds to 6ms. Therefore a V_{CC} fall time of 10 ms could be well appropriated in order to not trigger the overload detection circuitry. If the corresponding IC consumption, including the MOSFET drive, establishes at 1.6 mA (e.g. with a 10 nC Qg), we can calculate the required capacitor using the following formula: $\Delta t = \frac{\Delta V \cdot C}{i}$, with $\Delta V = 2$ V. Then for a wanted Δt of 10 ms, C equals 9 μ F or 22 μ F for a standard value. When an overload condition occurs, the IC blocks its internal circuitry and its consumption drops to 330 μ A typical. This happens at V_{CC} = 10 V and it remains stuck until V_{CC} reaches 5.3 V: we are in latchoff phase. Again, using the calculated 22 μ F and 330 μ A current consumption, this latchoff phase lasts: 313 ms.

NCP1308

Protecting Pin 8 Against Negative Spikes

As any CMOS controller, NCP1308 is sensitive to negative voltages that could appear on its pins (Figure 23). To avoid any adverse latchup of the IC, we strongly recommend to insert a resistor in series with pin 8. This

resistor prevents from adversely latching the controller in case of negative spikes appearing on the bulk capacitor during the power-off sequence. Please refer to the power dissipation section of this data sheet to see how to calculate this element.

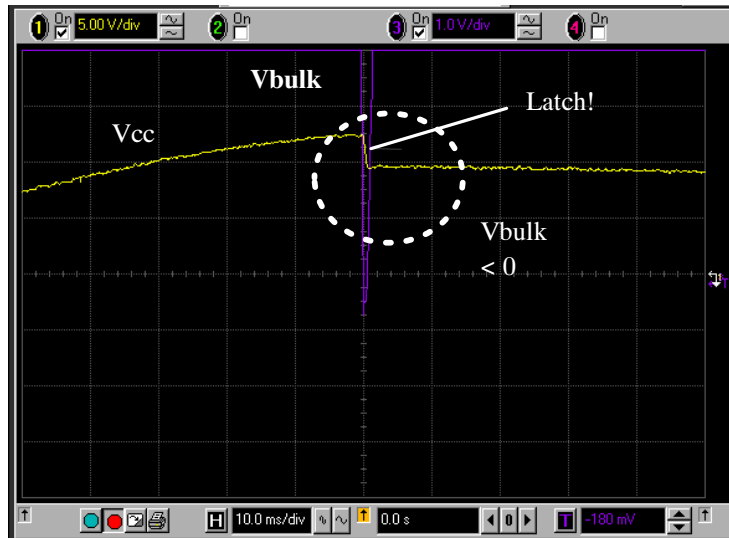

Figure 23. A negative spike can occur at mains switch-off if the quality coefficient of Cbulk-Lp is high enough.

Another option consists in adding a diode (or two in series for safety) from the VCC to the bulk capacitor. Figure 12 details this other option:

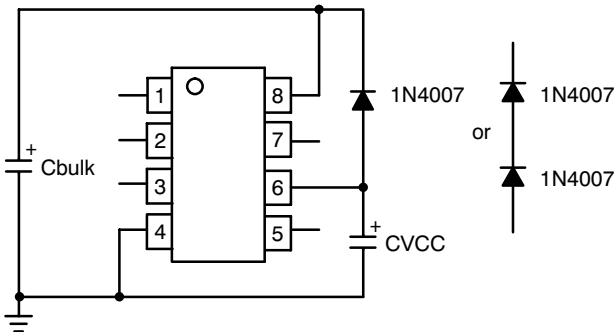

Figure 24. A diode will force the VCC to decrease at the same pace the bulk capacitor does, avoiding a negative ringing on the HV pin.

NCP1308

Operation Shots

Below are some oscilloscope shots captured at $V_{in} = 120$ VDC with a transformer featuring a $800 \mu\text{H}$ primary inductance:

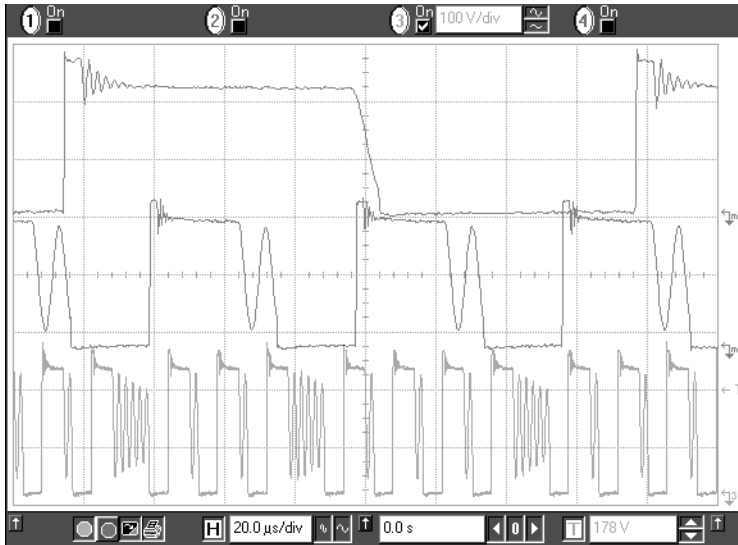

Figure 25. This plot gathers waveforms captured at three different operating points:
1st Upper Plot: Free run, valley switching operation, $P_{out} = 26$ W.
2nd Middle Plot: Min Toff clamps the switching frequency and selects the second valley.
3rd Lowest Plot: The skip slices the second valley pattern and will further expand the burst as P_{out} goes low.

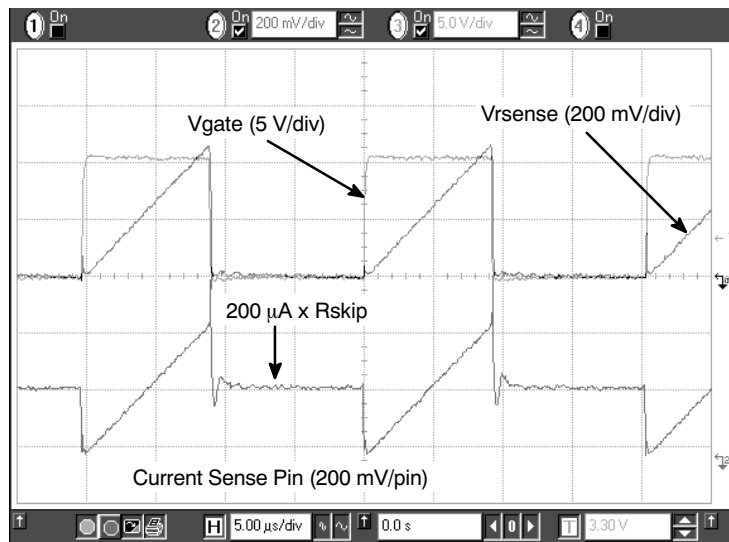

Figure 26. This picture explains how the $200 \mu\text{A}$ internal offset current creates the skip cycle level.

NCP1308

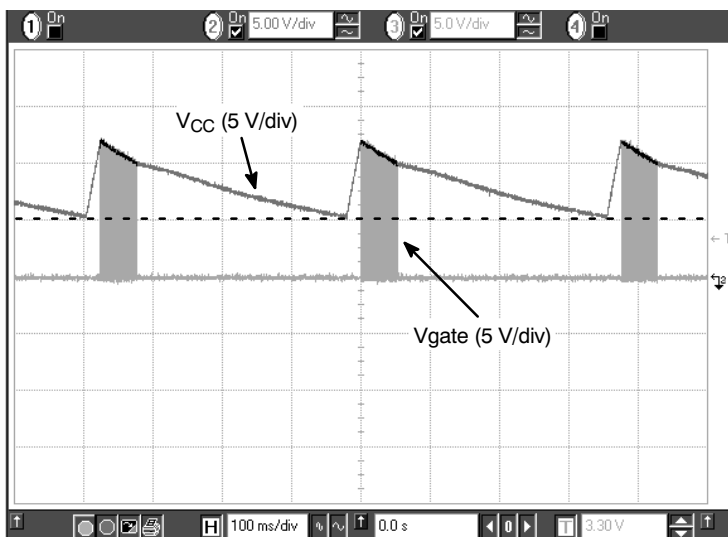

Figure 27. The short-circuit protection forces the IC to enter burst in presence of a secondary overload.

The product described herein (NCP1308), may be covered by one or more of the following U.S. patents: 6,362,067, 6,385,060, 6,385,061, 6,429,709, 6,587,357, 6,633,193. There may be other patents pending.

MECHANICAL CASE OUTLINE PACKAGE DIMENSIONS

ON Semiconductor®



SCALE 1:1

SOIC-8 NB
CASE 751-07
ISSUE AK

DATE 16 FEB 2011



- NOTES:
1. DIMENSIONING AND TOLERANCING PER ANSI Y14.5M, 1982.
 2. CONTROLLING DIMENSION: MILLIMETER.
 3. DIMENSION A AND B DO NOT INCLUDE MOLD PROTRUSION.
 4. MAXIMUM MOLD PROTRUSION 0.15 (0.006) PER SIDE.
 5. DIMENSION D DOES NOT INCLUDE DAMBAR PROTRUSION. ALLOWABLE DAMBAR PROTRUSION SHALL BE 0.127 (0.005) TOTAL IN EXCESS OF THE D DIMENSION AT MAXIMUM MATERIAL CONDITION.
 6. 751-01 THRU 751-06 ARE OBSOLETE. NEW STANDARD IS 751-07.

DIM	MILLIMETERS		INCHES	
	MIN	MAX	MIN	MAX
A	4.80	5.00	0.189	0.197
B	3.80	4.00	0.150	0.157
C	1.35	1.75	0.053	0.069
D	0.33	0.51	0.013	0.020
G	1.27 BSC		0.050 BSC	
H	0.10	0.25	0.004	0.010
J	0.19	0.25	0.007	0.010
K	0.40	1.27	0.016	0.050
M	0°	8°	0°	8°
N	0.25	0.50	0.010	0.020
S	5.80	6.20	0.228	0.244

SOLDERING FOOTPRINT*



*For additional information on our Pb-Free strategy and soldering details, please download the ON Semiconductor Soldering and Mounting Techniques Reference Manual, SOLDERRM/D.

GENERIC MARKING DIAGRAM*



XXXXXX = Specific Device Code
 A = Assembly Location
 L = Wafer Lot
 Y = Year
 W = Work Week
 ■ = Pb-Free Package

XXXXXX = Specific Device Code
 A = Assembly Location
 Y = Year
 WW = Work Week
 ■ = Pb-Free Package

*This information is generic. Please refer to device data sheet for actual part marking. Pb-Free indicator, "G" or microdot "•", may or may not be present. Some products may not follow the Generic Marking.

STYLES ON PAGE 2

DOCUMENT NUMBER:	98ASB42564B	Electronic versions are uncontrolled except when accessed directly from the Document Repository. Printed versions are uncontrolled except when stamped "CONTROLLED COPY" in red.
DESCRIPTION:	SOIC-8 NB	PAGE 1 OF 2

ON Semiconductor and ON are trademarks of Semiconductor Components Industries, LLC dba ON Semiconductor or its subsidiaries in the United States and/or other countries. ON Semiconductor reserves the right to make changes without further notice to any products herein. ON Semiconductor makes no warranty, representation or guarantee regarding the suitability of its products for any particular purpose, nor does ON Semiconductor assume any liability arising out of the application or use of any product or circuit, and specifically disclaims any and all liability, including without limitation special, consequential or incidental damages. ON Semiconductor does not convey any license under its patent rights nor the rights of others.

SOIC-8 NB
CASE 751-07
ISSUE AK

DATE 16 FEB 2011

- | | | | |
|--|---|---|---|
| <p>STYLE 1:
 PIN 1. EMITTER
 2. COLLECTOR
 3. COLLECTOR
 4. EMITTER
 5. EMITTER
 6. BASE
 7. BASE
 8. EMITTER</p> | <p>STYLE 2:
 PIN 1. COLLECTOR, DIE, #1
 2. COLLECTOR, #1
 3. COLLECTOR, #2
 4. COLLECTOR, #2
 5. BASE, #2
 6. EMITTER, #2
 7. BASE, #1
 8. EMITTER, #1</p> | <p>STYLE 3:
 PIN 1. DRAIN, DIE #1
 2. DRAIN, #1
 3. DRAIN, #2
 4. DRAIN, #2
 5. GATE, #2
 6. SOURCE, #2
 7. GATE, #1
 8. SOURCE, #1</p> | <p>STYLE 4:
 PIN 1. ANODE
 2. ANODE
 3. ANODE
 4. ANODE
 5. ANODE
 6. ANODE
 7. ANODE
 8. COMMON CATHODE</p> |
| <p>STYLE 5:
 PIN 1. DRAIN
 2. DRAIN
 3. DRAIN
 4. DRAIN
 5. GATE
 6. GATE
 7. SOURCE
 8. SOURCE</p> | <p>STYLE 6:
 PIN 1. SOURCE
 2. DRAIN
 3. DRAIN
 4. SOURCE
 5. SOURCE
 6. GATE
 7. GATE
 8. SOURCE</p> | <p>STYLE 7:
 PIN 1. INPUT
 2. EXTERNAL BYPASS
 3. THIRD STAGE SOURCE
 4. GROUND
 5. DRAIN
 6. GATE 3
 7. SECOND STAGE Vd
 8. FIRST STAGE Vd</p> | <p>STYLE 8:
 PIN 1. COLLECTOR, DIE #1
 2. BASE, #1
 3. BASE, #2
 4. COLLECTOR, #2
 5. COLLECTOR, #2
 6. EMITTER, #2
 7. EMITTER, #1
 8. COLLECTOR, #1</p> |
| <p>STYLE 9:
 PIN 1. EMITTER, COMMON
 2. COLLECTOR, DIE #1
 3. COLLECTOR, DIE #2
 4. EMITTER, COMMON
 5. EMITTER, COMMON
 6. BASE, DIE #2
 7. BASE, DIE #1
 8. EMITTER, COMMON</p> | <p>STYLE 10:
 PIN 1. GROUND
 2. BIAS 1
 3. OUTPUT
 4. GROUND
 5. GROUND
 6. BIAS 2
 7. INPUT
 8. GROUND</p> | <p>STYLE 11:
 PIN 1. SOURCE 1
 2. GATE 1
 3. SOURCE 2
 4. GATE 2
 5. DRAIN 2
 6. DRAIN 2
 7. DRAIN 1
 8. DRAIN 1</p> | <p>STYLE 12:
 PIN 1. SOURCE
 2. SOURCE
 3. SOURCE
 4. GATE
 5. DRAIN
 6. DRAIN
 7. DRAIN
 8. DRAIN</p> |
| <p>STYLE 13:
 PIN 1. N.C.
 2. SOURCE
 3. SOURCE
 4. GATE
 5. DRAIN
 6. DRAIN
 7. DRAIN
 8. DRAIN</p> | <p>STYLE 14:
 PIN 1. N-SOURCE
 2. N-GATE
 3. P-SOURCE
 4. P-GATE
 5. P-DRAIN
 6. P-DRAIN
 7. N-DRAIN
 8. N-DRAIN</p> | <p>STYLE 15:
 PIN 1. ANODE 1
 2. ANODE 1
 3. ANODE 1
 4. ANODE 1
 5. CATHODE, COMMON
 6. CATHODE, COMMON
 7. CATHODE, COMMON
 8. CATHODE, COMMON</p> | <p>STYLE 16:
 PIN 1. EMITTER, DIE #1
 2. BASE, DIE #1
 3. EMITTER, DIE #2
 4. BASE, DIE #2
 5. COLLECTOR, DIE #2
 6. COLLECTOR, DIE #2
 7. COLLECTOR, DIE #1
 8. COLLECTOR, DIE #1</p> |
| <p>STYLE 17:
 PIN 1. VCC
 2. V2OUT
 3. V1OUT
 4. TXE
 5. RXE
 6. VEE
 7. GND
 8. ACC</p> | <p>STYLE 18:
 PIN 1. ANODE
 2. ANODE
 3. SOURCE
 4. GATE
 5. DRAIN
 6. DRAIN
 7. CATHODE
 8. CATHODE</p> | <p>STYLE 19:
 PIN 1. SOURCE 1
 2. GATE 1
 3. SOURCE 2
 4. GATE 2
 5. DRAIN 2
 6. MIRROR 2
 7. DRAIN 1
 8. MIRROR 1</p> | <p>STYLE 20:
 PIN 1. SOURCE (N)
 2. GATE (N)
 3. SOURCE (P)
 4. GATE (P)
 5. DRAIN
 6. DRAIN
 7. DRAIN
 8. DRAIN</p> |
| <p>STYLE 21:
 PIN 1. CATHODE 1
 2. CATHODE 2
 3. CATHODE 3
 4. CATHODE 4
 5. CATHODE 5
 6. COMMON ANODE
 7. COMMON ANODE
 8. CATHODE 6</p> | <p>STYLE 22:
 PIN 1. I/O LINE 1
 2. COMMON CATHODE/VCC
 3. COMMON CATHODE/VCC
 4. I/O LINE 3
 5. COMMON ANODE/GND
 6. I/O LINE 4
 7. I/O LINE 5
 8. COMMON ANODE/GND</p> | <p>STYLE 23:
 PIN 1. LINE 1 IN
 2. COMMON ANODE/GND
 3. COMMON ANODE/GND
 4. LINE 2 IN
 5. LINE 2 OUT
 6. COMMON ANODE/GND
 7. COMMON ANODE/GND
 8. LINE 1 OUT</p> | <p>STYLE 24:
 PIN 1. BASE
 2. EMITTER
 3. COLLECTOR/ANODE
 4. COLLECTOR/ANODE
 5. CATHODE
 6. CATHODE
 7. COLLECTOR/ANODE
 8. COLLECTOR/ANODE</p> |
| <p>STYLE 25:
 PIN 1. VIN
 2. N/C
 3. REXT
 4. GND
 5. IOUT
 6. IOUT
 7. IOUT
 8. IOUT</p> | <p>STYLE 26:
 PIN 1. GND
 2. dv/dt
 3. ENABLE
 4. ILIMIT
 5. SOURCE
 6. SOURCE
 7. SOURCE
 8. VCC</p> | <p>STYLE 27:
 PIN 1. ILIMIT
 2. OVLO
 3. UVLO
 4. INPUT+
 5. SOURCE
 6. SOURCE
 7. SOURCE
 8. DRAIN</p> | <p>STYLE 28:
 PIN 1. SW_TO_GND
 2. DASIC OFF
 3. DASIC_SW_DET
 4. GND
 5. V_MON
 6. VBULK
 7. VBULK
 8. VIN</p> |
| <p>STYLE 29:
 PIN 1. BASE, DIE #1
 2. EMITTER, #1
 3. BASE, #2
 4. EMITTER, #2
 5. COLLECTOR, #2
 6. COLLECTOR, #2
 7. COLLECTOR, #1
 8. COLLECTOR, #1</p> | <p>STYLE 30:
 PIN 1. DRAIN 1
 2. DRAIN 1
 3. GATE 2
 4. SOURCE 2
 5. SOURCE 1/DRAIN 2
 6. SOURCE 1/DRAIN 2
 7. SOURCE 1/DRAIN 2
 8. GATE 1</p> | | |

DOCUMENT NUMBER:	98ASB42564B	Electronic versions are uncontrolled except when accessed directly from the Document Repository. Printed versions are uncontrolled except when stamped "CONTROLLED COPY" in red.
DESCRIPTION:	SOIC-8 NB	PAGE 2 OF 2

ON Semiconductor and  are trademarks of Semiconductor Components Industries, LLC dba ON Semiconductor or its subsidiaries in the United States and/or other countries. ON Semiconductor reserves the right to make changes without further notice to any products herein. ON Semiconductor makes no warranty, representation or guarantee regarding the suitability of its products for any particular purpose, nor does ON Semiconductor assume any liability arising out of the application or use of any product or circuit, and specifically disclaims any and all liability, including without limitation special, consequential or incidental damages. ON Semiconductor does not convey any license under its patent rights nor the rights of others.

ON Semiconductor and  are trademarks of Semiconductor Components Industries, LLC dba ON Semiconductor or its subsidiaries in the United States and/or other countries. ON Semiconductor owns the rights to a number of patents, trademarks, copyrights, trade secrets, and other intellectual property. A listing of ON Semiconductor's product/patent coverage may be accessed at www.onsemi.com/site/pdf/Patent-Marking.pdf. ON Semiconductor reserves the right to make changes without further notice to any products herein. ON Semiconductor makes no warranty, representation or guarantee regarding the suitability of its products for any particular purpose, nor does ON Semiconductor assume any liability arising out of the application or use of any product or circuit, and specifically disclaims any and all liability, including without limitation special, consequential or incidental damages. Buyer is responsible for its products and applications using ON Semiconductor products, including compliance with all laws, regulations and safety requirements or standards, regardless of any support or applications information provided by ON Semiconductor. "Typical" parameters which may be provided in ON Semiconductor data sheets and/or specifications can and do vary in different applications and actual performance may vary over time. All operating parameters, including "Typicals" must be validated for each customer application by customer's technical experts. ON Semiconductor does not convey any license under its patent rights nor the rights of others. ON Semiconductor products are not designed, intended, or authorized for use as a critical component in life support systems or any FDA Class 3 medical devices or medical devices with a same or similar classification in a foreign jurisdiction or any devices intended for implantation in the human body. Should Buyer purchase or use ON Semiconductor products for any such unintended or unauthorized application, Buyer shall indemnify and hold ON Semiconductor and its officers, employees, subsidiaries, affiliates, and distributors harmless against all claims, costs, damages, and expenses, and reasonable attorney fees arising out of, directly or indirectly, any claim of personal injury or death associated with such unintended or unauthorized use, even if such claim alleges that ON Semiconductor was negligent regarding the design or manufacture of the part. ON Semiconductor is an Equal Opportunity/Affirmative Action Employer. This literature is subject to all applicable copyright laws and is not for resale in any manner.

PUBLICATION ORDERING INFORMATION

LITERATURE FULFILLMENT:

Email Requests to: orderlit@onsemi.com

ON Semiconductor Website: www.onsemi.com

TECHNICAL SUPPORT

North American Technical Support:
Voice Mail: 1 800-282-9855 Toll Free USA/Canada
Phone: 011 421 33 790 2910

Europe, Middle East and Africa Technical Support:

Phone: 00421 33 790 2910

For additional information, please contact your local Sales Representative