

# NB6L572M

## 2.5V / 3.3V Differential 4:1 Mux to 1:2 CML Clock/Data Fanout / Translator

### Multi-Level Inputs w/ Internal Termination

#### Description

The NB6L572M is a high performance differential 4:1 Clock / Data input multiplexer and a 1:2 CML Clock / Data fanout buffer that operates up to 6 GHz / 8 Gbps respectively with a 2.5 V or 3.3 V power supply.

The differential Clock / Data inputs have internal 50  $\Omega$  termination resistors and will accept differential LVPECL, CML, or LVDS logic levels. The NB6L572M incorporates a pair of Select pins that will choose one of four differential inputs and will produce two identical CML output copies of Clock or Data.

As such, the NB6L572M is ideal for SONET, GigE, Fiber Channel, Backplane and other Clock/Data distribution applications.

The two differential CML outputs will swing 400 mV when externally loaded and terminated with a 50  $\Omega$  resistor to  $V_{CC}$  and are optimized for low skew and minimal jitter.

The NB6L572M is offered in a low profile 5x5mm 32-pin QFN Pb-Free package. Application notes, models, and support documentation are available at [www.onsemi.com](http://www.onsemi.com). The NB6L572M is a member of the ECLinPS MAX™ family of high performance clock products.

#### Features

- Input Data Rate > 8 Gb/s Typical
- Data Dependent Jitter < 10 ps
- Maximum Input Clock Frequency > 6 GHz Typical
- Random Clock Jitter < 0.8 ps RMS
- Low Skew 1:2 CML Outputs, < 15 ps max
- 4:1 Multi-Level Mux Inputs, accepts LVPECL, CML, LVDS
- 200 ps Typical Propagation Delay
- 35 ps Typical Rise and Fall Times
- Differential CML Outputs, 400 mV Peak-to-Peak, Typical
- Operating Range:  $V_{CC} = 2.375$  V to 3.6 V with  $GND = 0$  V
- Internal 50  $\Omega$  Input Termination Resistors
- $V_{REFAC}$  Reference Output
- QFN-32 Package, 5mm x 5mm
- 40°C to +85°C Ambient Operating Temperature
- These are Pb-Free Devices



ON Semiconductor®

<http://onsemi.com>

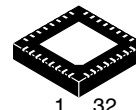

QFN32  
MN SUFFIX  
CASE 488AM

#### MARKING DIAGRAM

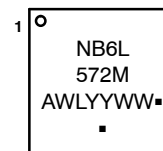

A = Assembly Location  
WL = Wafer Lot  
YY = Year  
WW = Work Week  
▪ = Pb-Free Package

(Note: Microdot may be in either location)

#### ORDERING INFORMATION

See detailed ordering and shipping information on page 8 of this data sheet.

# NB6L572M

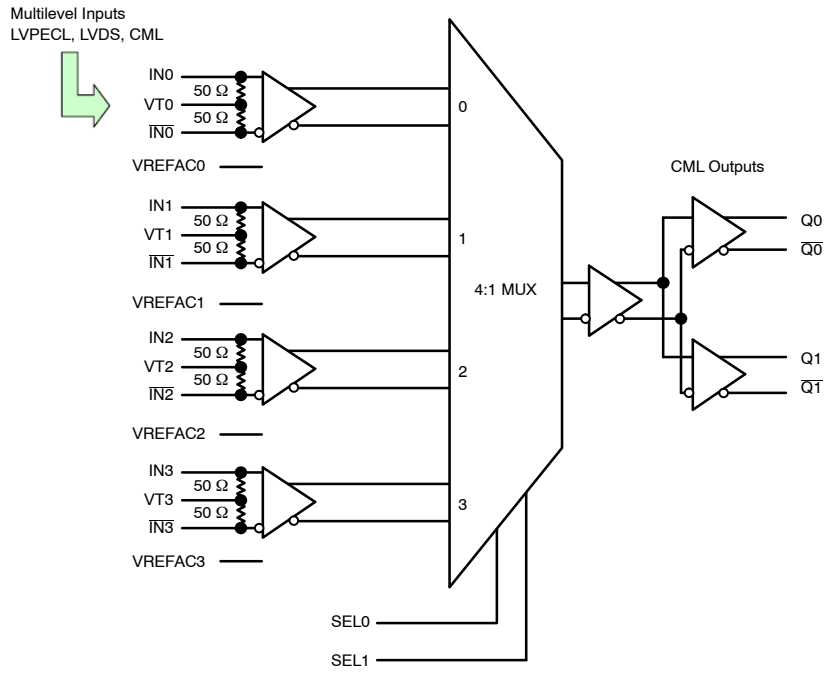

Figure 1. Simplified Block Diagram

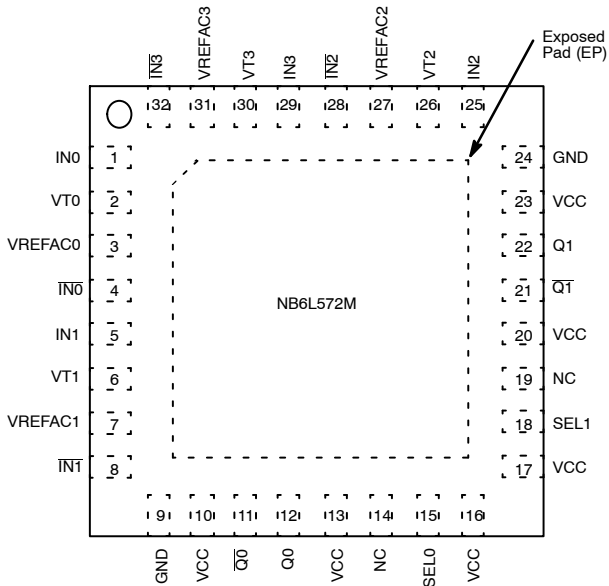

Figure 2. Pinout: QFN-32 (Top View)

Table 1. INPUT SELECT FUNCTION TABLE

SEL1*	SEL0*	Clock / Data Input Selected
0	0	IN0 Input Selected
0	1	IN1 Input Selected
1	0	IN2 Input Selected
1	1	IN3 Input Selected

\*Defaults HIGH when left open.

# NB6L572M

**Table 2. PIN DESCRIPTION**

Pin Number	Pin Name	I/O	Pin Description
1, 4 5, 8 25, 28 29, 32	IN0, $\overline{IN0}$ IN1, $\overline{IN1}$ IN2, $\overline{IN2}$ IN3, $\overline{IN3}$	LVPECL, CML, LVDS Input	Non-inverted, Inverted, Differential Clock or Data Inputs
2, 6 26, 30	VT0, VT1 VT2, VT3		Internal 100 $\Omega$ Center-tapped Termination Pin for INx/ $\overline{INx}$
15 18	SEL0 SEL1	LVTTTL/LVCMOS Input	Input Select pins, default HIGH when left open through a 131 k $\Omega$ pullup resistor. Input logic threshold is $V_{CC}/2$ . See Select Function, Table 1.
14, 19	NC	–	No Connect
10, 13, 16 17, 20, 23	VCC	–	Positive Supply Voltage. All VCC pins must be connected to the positive power supply for correct DC and AC operation.
11, 12 21, 22	$\overline{Q0}$ , Q0 $\overline{Q1}$ , Q1	CML Output	Non-inverted, Inverted Differential Outputs.
9, 24	GND		Negative Supply Voltage, connected to Ground
3 7 27 31	VREF-AC0 VREF-AC1 VREF-AC2 VREF-AC3	–	Output Voltage Reference for Capacitor-Coupled Inputs
–	EP	–	The Exposed Pad (EP) on the QFN-32 package bottom is thermally connected to the die for improved heat transfer out of package. The exposed pad must be attached to a heat-sinking conduit. The pad is electrically connected to the die, and must be electrically connected to GND.

1. In the differential configuration when the input termination pins (VT0, VT1, VT2, VT3) are connected to a common termination voltage or left open, and if no signal is applied on INx/ $\overline{INx}$  input, then the device will be susceptible to self-oscillation.
2. All VCC, and GND pins must be externally connected to a power supply for proper operation.

# NB6L572M

**Table 3. ATTRIBUTES**

Characteristics		Value
ESD Protection	Human Body Model Machine Model	> 2 kV > 200 V
R <sub>PU</sub> – SELx Input Pull-up Resistor		131 kΩ
Moisture Sensitivity (Note 3)	QFN-32	Level 1
Flammability Rating	Oxygen Index: 28 to 34	UL 94 V-0 @ 0.125 in
Transistor Count		275
Meets or exceeds JEDEC Spec EIA/JESD78 IC Latchup Test		

3. For additional information, see Application Note AND8003/D.

**Table 4. MAXIMUM RATINGS**

Symbol	Parameter	Condition 1	Condition 2	Rating	Unit
V <sub>CC</sub>	Positive Power Supply	GND = 0 V		-0.5 V to +4.0	V
V <sub>IN</sub>	Positive Input Voltage	GND = 0 V		-0.5 to V <sub>CC</sub> +0.5	V
V <sub>INPP</sub>	Differential Input Voltage  I <sub>N</sub> – I <sub>N̄</sub>			1.89	V
I <sub>out</sub>	Output Current Through R <sub>T</sub> (50 Ω Resistor)			± 40	mA
I <sub>IN</sub>	Input current Through RT (50 Ω resistor)			± 40	mA
I <sub>VREFAC</sub>	VREFAC Sink or Source Current			± 1.5	mA
T <sub>A</sub>	Operating Temperature Range			-40 to +85	°C
T <sub>stg</sub>	Storage Temperature Range			-65 to +150	°C
θ <sub>JA</sub>	Thermal Resistance (Junction-to-Ambient) (Note 4)	0 lfpm 500 lfpm	QFN32 QFN32	31 27	°C/W
θ <sub>JC</sub>	Thermal Resistance (Junction-to-Case) (Note 4)		QFN32	12	°C/W
T <sub>sol</sub>	Wave Solder	≤ 20 sec		265	°C

Stresses exceeding Maximum Ratings may damage the device. Maximum Ratings are stress ratings only. Functional operation above the Recommended Operating Conditions is not implied. Extended exposure to stresses above the Recommended Operating Conditions may affect device reliability.

4. JEDEC standard multilayer board – 2S2P (2 signal, 2 power) with 8 filled thermal vias under exposed pad.

# NB6L572M

**Table 5. DC CHARACTERISTICS CML OUTPUT**  $V_{CC} = 2.375 \text{ V to } 3.6 \text{ V}$ ,  $GND = 0 \text{ V}$ ,  $T_A = -40^\circ\text{C to } +85^\circ\text{C}$  (Note 5)

Symbol	Characteristic	Min	Typ	Max	Unit
--------	----------------	-----	-----	-----	------

## POWER SUPPLY

$V_{CC}$	Power Supply Voltage	$V_{CC} = 3.3 \text{ V}$ $V_{CC} = 2.5 \text{ V}$	3.0 2.375	3.3 2.5	3.6 2.625	V
$I_{CC}$	Power Supply Current for $V_{CC}$ (Inputs and Outputs Open)	$V_{CC} = 3.3 \text{ V}$ $V_{CC} = 2.5 \text{ V}$		130 115	165 150	mA

## CML OUTPUTS (Note 6)

$V_{OH}$	Output HIGH Voltage	$V_{CC} = 3.3 \text{ V}$ $V_{CC} = 2.5 \text{ V}$	$V_{CC} - 30$ 3270 2470	$V_{CC} - 10$ 3290 2490	$V_{CC}$ 3300 2500	mV
$V_{OL}$	Output LOW Voltage	$V_{CC} = 3.3 \text{ V}$ $V_{CC} = 2.5 \text{ V}$	$V_{CC} - 650$ 2650 $V_{CC} - 650$ 1850	$V_{CC} - 450$ 2850 $V_{CC} - 450$ 2050	$V_{CC} - 300$ 3000 $V_{CC} - 300$ 2200	mV

## DIFFERENTIAL CLOCK INPUTS DRIVEN SINGLE-ENDED (Figures 5 & 6) (Note 8)

$V_{IH}$	Single-ended Input HIGH Voltage		$V_{th} + 100$		$V_{CC}$	mV
$V_{IL}$	Single-ended Input LOW Voltage		GND		$V_{th} - 100$	mV
$V_{th}$	Input Threshold Reference Voltage Range (Note 8)		1100		$V_{CC} - 100$	mV
$V_{ISE}$	Single-ended Input Voltage ( $V_{IH} - V_{IL}$ )		200		1200	mV

## VREFAC

$V_{REF-AC}$	Output Reference Voltage (100 $\mu\text{A}$ Load)		1050	$V_{CC} - 1250$	$V_{CC} - 1050$	mV
--------------	---	--	------	-----------------	-----------------	----

## DIFFERENTIAL INPUTS DRIVEN DIFFERENTIALLY (Figures 7 & 8) (Note 9)

$V_{IHD}$	Differential Input HIGH Voltage ( $I_N, \overline{I_N}$ )		1200		$V_{CC}$	mV
$V_{ILD}$	Differential Input LOW Voltage ( $I_N, \overline{I_N}$ )		0		$V_{IHD} - 100$	mV
$V_{ID}$	Differential Input Voltage ( $I_N, \overline{I_N}$ ) ( $V_{IHD} - V_{ILD}$ )		100		1200	mV
$V_{CMR}$	Input Common Mode Range (Differential Configuration, Note 10) (Figure 9)		1050		$V_{CC} - 50$	mV
$I_{IH}$	Input HIGH Current $I_N / \overline{I_N}$ ( $V_{TIN} / \overline{V_{TIN}}$ Open)		-150		150	$\mu\text{A}$
$I_{IL}$	Input LOW Current $I_N / \overline{I_N}$ ( $V_{TIN} / \overline{V_{TIN}}$ Open)		-150		150	$\mu\text{A}$

## CONTROL INPUT (SELx Pin)

$V_{IH}$	Input HIGH Voltage for Control Pin		$V_{CC} \times 0.65$		$V_{CC}$	V
$V_{IL}$	Input LOW Voltage for Control Pin		GND		$V_{CC} \times 0.35$	V
$I_{IH}$	Input HIGH Current		-150		150	$\mu\text{A}$
$I_{IL}$	Input LOW Current		-150		150	$\mu\text{A}$

## TERMINATION RESISTORS

$R_{TIN}$	Internal Input Termination Resistor (Measured from $I_{Nx}$ to $V_{Tx}$ )		45	50	55	$\Omega$
$R_{TOUT}$	Internal Output Termination Resistor		45	50	55	$\Omega$

NOTE: Device will meet the specifications after thermal equilibrium has been established when mounted in a test socket or printed circuit board with maintained transverse airflow greater than 500 lpm. Electrical parameters are guaranteed only over the declared operating temperature range. Functional operation of the device exceeding these conditions is not implied. Device specification limit values are applied individually under normal operating conditions and not valid simultaneously.

- Input and Output parameters vary 1:1 with  $V_{CC}$ .
- CML outputs loaded with 50  $\Omega$  to  $V_{CC}$  for proper operation.
- $V_{th}$  is applied to the complementary input when operating in single-ended mode.
- $V_{th}$ ,  $V_{IH}$ ,  $V_{IL}$ , and  $V_{ISE}$  parameters must be complied with simultaneously.
- $V_{IHD}$ ,  $V_{ILD}$ ,  $V_{ID}$  and  $V_{CMR}$  parameters must be complied with simultaneously.
- $V_{CMR}$  min varies 1:1 with GND,  $V_{CMR}$  max varies 1:1 with  $V_{CC}$ . The  $V_{CMR}$  range is referenced to the most positive side of the differential input signal.

# NB6L572M

**Table 6. AC CHARACTERISTICS**  $V_{CC} = 2.375\text{ V to }3.6\text{ V}$ ,  $GND = 0\text{ V}$ ,  $T_A = -40^\circ\text{C to }+85^\circ\text{C}$  (Note 11)

Symbol	Characteristic	Min	Typ	Max	Unit
$f_{MAX}$	Maximum Input Clock Frequency $V_{OUT} \geq 250\text{ mV}$	5	6		GHz
$f_{DATAMAX}$	Maximum Operating Data Rate NRZ, (PRBS23)	6.5	8		Gbps
$f_{SEL}$	Maximum Toggle Frequency, SELx	20	40		MHz
$V_{OUTPP}$	Output Voltage Amplitude (@ $V_{INPPmin}$ ) $f_{in} \leq 5\text{ GHz}$ (Note 12) (Figure 10)	250	400		mV
$t_{PLH}$ , $t_{PHL}$	Propagation Delay to Differential Outputs Measured at Differential Crosspoint	@ 1 GHz $INx/\overline{INx}$ to $Qx/\overline{Qx}$ @ 50 MHz SELx to Qx	125 4	200 10	ps ns
$t_{PD}$ Tempco	Differential Propagation Delay Temperature Coefficient		100		$\Delta fs/^\circ C$
tskew	Output – Output skew (within device) (Note 13) Device – Device skew ( $tpdmax - tpdmin$ )		0 5	15 25	ps
$t_{DC}$	Output Clock Duty Cycle (Reference Duty Cycle = 50%) $f_{in} = 1\text{ GHz}$	45	50	55	%
$\Phi_N$	Phase Noise, $f_{in} = 1\text{ GHz}$				dBc
		10 kHz	-134		
		100 kHz	-136		
		1 MHz	-149		
		10 MHz	-150		
		20 MHz	-150		
		40 MHz	-150		
$t_{J\Phi N}$	Integrated Phase Jitter (Figure x) $f_{in} = 1\text{ GHz}$ , 12 kHz – 20 MHz Offset (RMS)		35		fs
$t_{JITTER}$	Random Clock Jitter, RJ(RMS) (Note 14) $f_{in} \leq 5\text{ GHz}$ Deterministic Jitter, DJ (Note 15) ( $FR4 \leq 12'$ ) $f_{in} \leq 6.5\text{ Gbps}$		0.2 1	0.8 5	ps RMS ps pk-pk
	Crosstalk Induced Jitter (Adjacent Channel) (Note 16)		0.35	0.7	ps RMS
$V_{INPP}$	Input Voltage Swing (Differential Configuration) (Note 17)	100		1200	mV
$t_r, t_f$	Output Rise/Fall Times @ 1 GHz; (20% – 80%), $V_{IN} = 400\text{ mV } Qx, \overline{Qx}$	20	35	50	ps

NOTE: Device will meet the specifications after thermal equilibrium has been established when mounted in a test socket or printed circuit board with maintained transverse airflow greater than 500 lpm. Electrical parameters are guaranteed only over the declared operating temperature range. Functional operation of the device exceeding these conditions is not implied. Device specification limit values are applied individually under normal operating conditions and not valid simultaneously.

11. Measured using a 100 mVpk-pk source, 50% duty cycle clock source. All output loading with external 50  $\Omega$  to  $V_{CC}$ . Input edge rates 40 ps (20% – 80%).
12. Output voltage swing is a single-ended measurement operating in differential mode.
13. Skew is measured between outputs under identical transitions and conditions. Duty cycle skew is defined only for differential operation when the delays are measured from cross-point of the inputs to the cross-point of the outputs.
14. Additive RMS jitter with 50% duty cycle clock signal.
15. Additive Peak-to-Peak data dependent jitter with input NRZ data at PRBS23.
16. Crosstalk is measured at the output while applying two similar clock frequencies that are asynchronous with respect to each other at the inputs.
17. Input voltage swing is a single-ended measurement operating in differential mode.

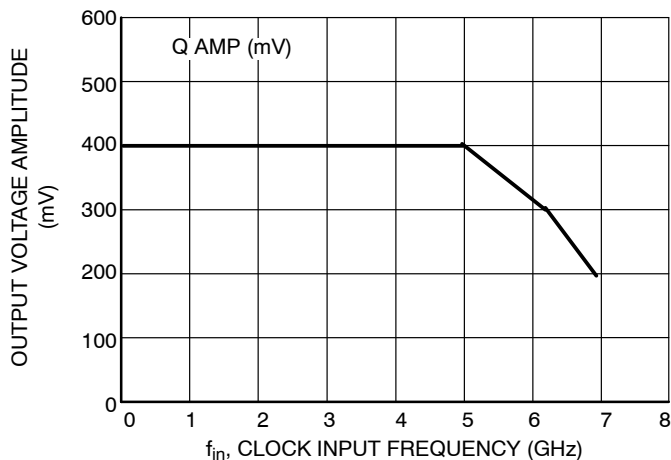

**Figure 3. Clock Output Voltage Amplitude ( $V_{OUTPP}$ ) vs. Input Frequency ( $f_{in}$ ) at Ambient Temperature (Typical)**

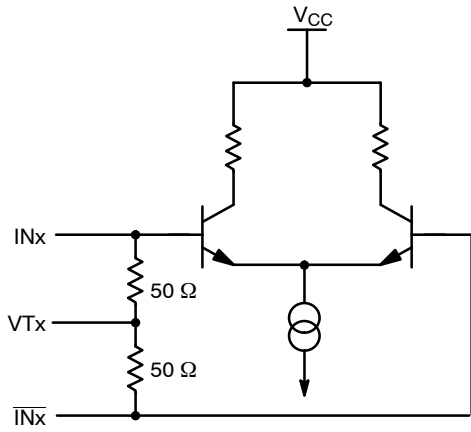

Figure 4. Input Structure

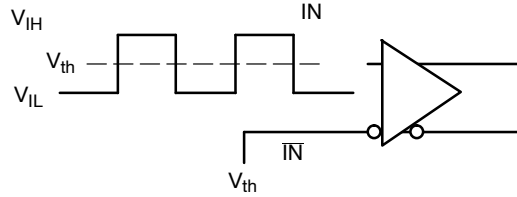

Figure 5. Differential Input Driven Single-Ended

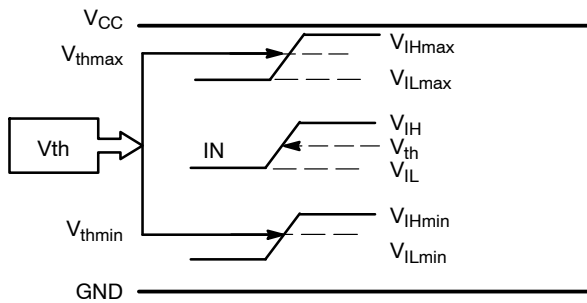

Figure 6.  $V_{th}$  Diagram

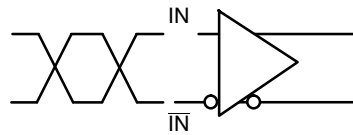

Figure 7. Differential Inputs Driven Differentially

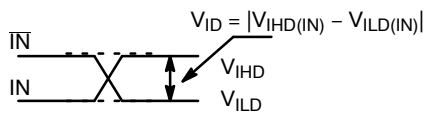

Figure 8. Differential Inputs Driven Differentially

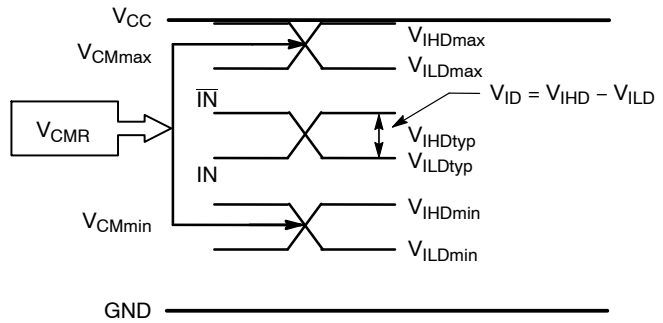

Figure 9.  $V_{CMR}$  Diagram

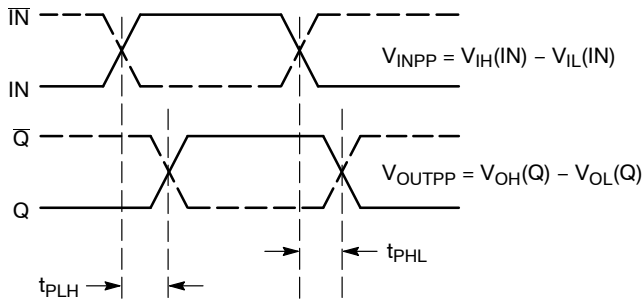

Figure 10. AC Reference Measurement

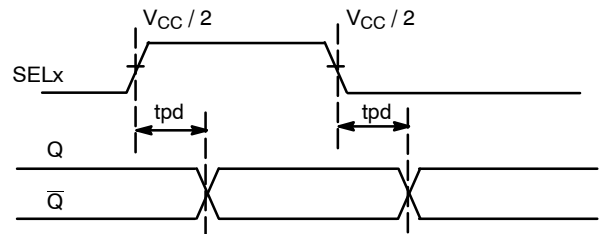

Figure 11. SELx to Qx Timing Diagram

# NB6L572M

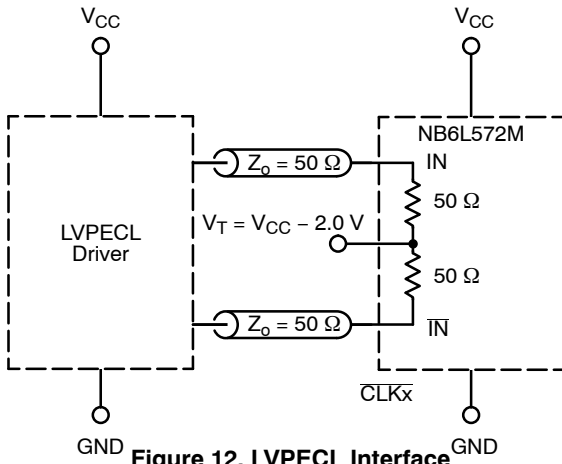

Figure 12. LVPECL Interface

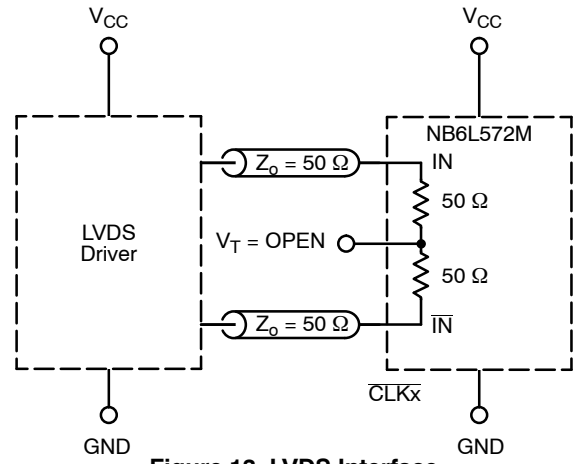

Figure 13. LVDS Interface

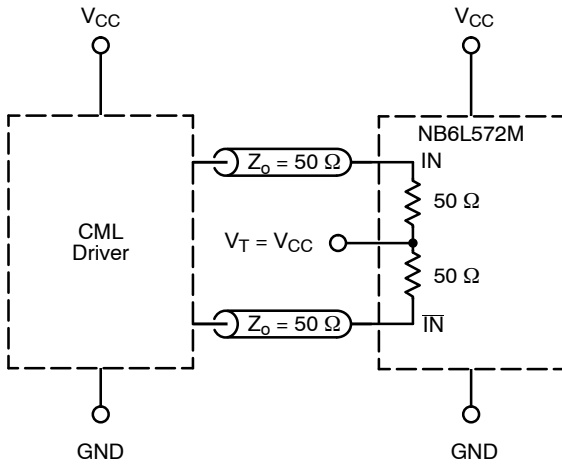

Figure 14. Standard 50 Ω Load CML Interface

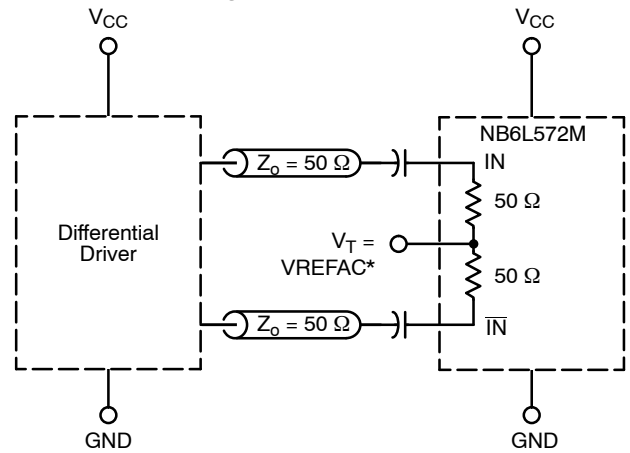

Figure 15. Capacitor-Coupled Differential Interface ( $V_T$  Connected to External  $V_{REFAC}$ )

\* $V_{REFAC}$  bypassed to ground with a 0.01 μF capacitor.

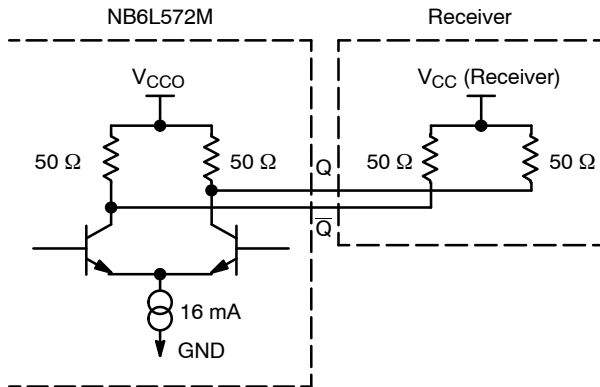

Figure 16. Typical CML Output Structure and Termination ( $V_{CC} = 2.5 \text{ V}$  or  $3.3 \text{ V}$ )

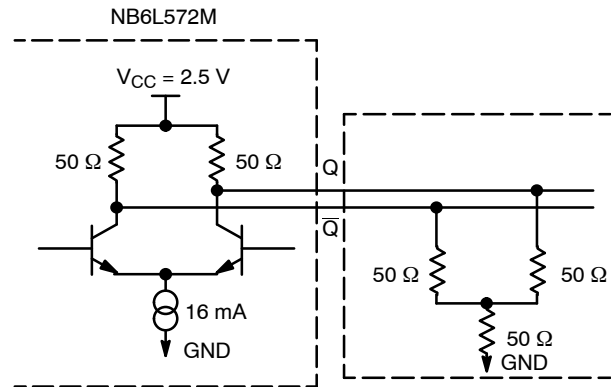

Figure 17. Alternative Output Termination ( $V_{CC} = 2.5 \text{ V}$ , Only)

## DEVICE ORDERING INFORMATION

Device	Package	Shipping <sup>†</sup>
NB6L572MMNG	QFN-32 (Pb-Free)	74 Units / Rail
NB6L572MMNR4G	QFN-32 (Pb-Free)	1000 / Tape & Reel

<sup>†</sup>For information on tape and reel specifications, including part orientation and tape sizes, please refer to our Tape and Reel Packaging Specifications Brochure, BRD8011/D.

ECLinPS MAX is a trademark of Semiconductor Component Industries, LLC (SCILLC).



# MECHANICAL CASE OUTLINE

## PACKAGE DIMENSIONS

ON Semiconductor®

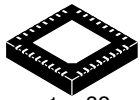

1 32

SCALE 2:1

QFN32 5x5, 0.5P  
CASE 488AM  
ISSUE A

DATE 23 OCT 2013

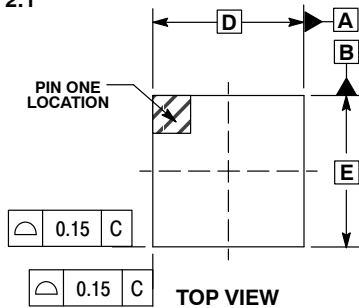

TOP VIEW

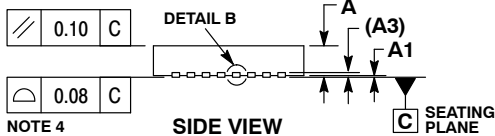

SIDE VIEW

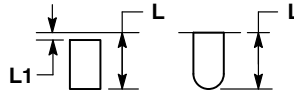

DETAIL A  
ALTERNATE TERMINAL  
CONSTRUCTIONS

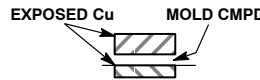

DETAIL B  
ALTERNATE  
CONSTRUCTION

NOTES:

1. DIMENSIONS AND TOLERANCING PER ASME Y14.5M, 1994.
2. CONTROLLING DIMENSION: MILLIMETERS.
3. DIMENSION b APPLIES TO PLATED TERMINAL AND IS MEASURED BETWEEN 0.15 AND 0.30MM FROM THE TERMINAL TIP. COPLANARITY APPLIES TO THE EXPOSED PAD AS WELL AS THE TERMINALS.
4. COPLANARITY APPLIES TO THE EXPOSED PAD AS WELL AS THE TERMINALS.

MILLIMETERS		
DIM	MIN	MAX
A	0.80	1.00
A1	---	0.05
A3	0.20	REF
b	0.18	0.30
D	5.00	BSC
D2	2.95	3.25
E	5.00	BSC
E2	2.95	3.25
e	0.50	BSC
K	0.20	---
L	0.30	0.50
L1	---	0.15

GENERIC MARKING DIAGRAM\*

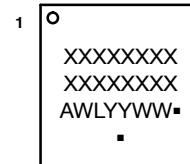

- XXXXXX = Specific Device Code
- A = Assembly Location
- WL = Wafer Lot
- YY = Year
- WW = Work Week
- = Pb-Free Package

(Note: Microdot may be in either location)

\*This information is generic. Please refer to device data sheet for actual part marking.

Pb-Free indicator, "G" or microdot "▪", may or may not be present.

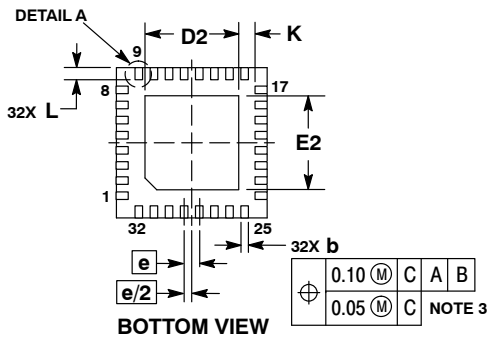

BOTTOM VIEW

RECOMMENDED SOLDERING FOOTPRINT\*

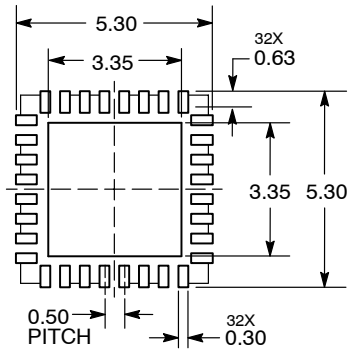

DIMENSION: MILLIMETERS

\*For additional information on our Pb-Free strategy and soldering details, please download the ON Semiconductor Soldering and Mounting Techniques Reference Manual, SOLDERRM/D.

DOCUMENT NUMBER:	98AON20032D	Electronic versions are uncontrolled except when accessed directly from the Document Repository. Printed versions are uncontrolled except when stamped "CONTROLLED COPY" in red.
DESCRIPTION:	QFN32 5x5 0.5P	PAGE 1 OF 1

ON Semiconductor and ON are trademarks of Semiconductor Components Industries, LLC dba ON Semiconductor or its subsidiaries in the United States and/or other countries. ON Semiconductor reserves the right to make changes without further notice to any products herein. ON Semiconductor makes no warranty, representation or guarantee regarding the suitability of its products for any particular purpose, nor does ON Semiconductor assume any liability arising out of the application or use of any product or circuit, and specifically disclaims any and all liability, including without limitation special, consequential or incidental damages. ON Semiconductor does not convey any license under its patent rights nor the rights of others.

**onsemi**, **Onsemi**, and other names, marks, and brands are registered and/or common law trademarks of Semiconductor Components Industries, LLC dba "**onsemi**" or its affiliates and/or subsidiaries in the United States and/or other countries. **onsemi** owns the rights to a number of patents, trademarks, copyrights, trade secrets, and other intellectual property. A listing of **onsemi**'s product/patent coverage may be accessed at [www.onsemi.com/site/pdf/Patent-Marking.pdf](http://www.onsemi.com/site/pdf/Patent-Marking.pdf). **onsemi** reserves the right to make changes at any time to any products or information herein, without notice. The information herein is provided "as-is" and **onsemi** makes no warranty, representation or guarantee regarding the accuracy of the information, product features, availability, functionality, or suitability of its products for any particular purpose, nor does **onsemi** assume any liability arising out of the application or use of any product or circuit, and specifically disclaims any and all liability, including without limitation special, consequential or incidental damages. Buyer is responsible for its products and applications using **onsemi** products, including compliance with all laws, regulations and safety requirements or standards, regardless of any support or applications information provided by **onsemi**. "Typical" parameters which may be provided in **onsemi** data sheets and/or specifications can and do vary in different applications and actual performance may vary over time. All operating parameters, including "Typicals" must be validated for each customer application by customer's technical experts. **onsemi** does not convey any license under any of its intellectual property rights nor the rights of others. **onsemi** products are not designed, intended, or authorized for use as a critical component in life support systems or any FDA Class 3 medical devices or medical devices with a same or similar classification in a foreign jurisdiction or any devices intended for implantation in the human body. Should Buyer purchase or use **onsemi** products for any such unintended or unauthorized application, Buyer shall indemnify and hold **onsemi** and its officers, employees, subsidiaries, affiliates, and distributors harmless against all claims, costs, damages, and expenses, and reasonable attorney fees arising out of, directly or indirectly, any claim of personal injury or death associated with such unintended or unauthorized use, even if such claim alleges that **onsemi** was negligent regarding the design or manufacture of the part. **onsemi** is an Equal Opportunity/Affirmative Action Employer. This literature is subject to all applicable copyright laws and is not for resale in any manner.

## PUBLICATION ORDERING INFORMATION

### LITERATURE FULFILLMENT:

Email Requests to: [orderlit@onsemi.com](mailto:orderlit@onsemi.com)

**onsemi Website:** [www.onsemi.com](http://www.onsemi.com)

### TECHNICAL SUPPORT

**North American Technical Support:**  
Voice Mail: 1 800-282-9855 Toll Free USA/Canada  
Phone: 011 421 33 790 2910

**Europe, Middle East and Africa Technical Support:**

Phone: 00421 33 790 2910

For additional information, please contact your local Sales Representative