

FUSB380C

Product Preview

Autonomous USB Type-C Passive Cable Marker

Description

The FUSB380C provides a small footprint solution for passive cable applications. 28 V Tolerant VCONN and CC provides VBUS shorting protection. One FUSB380C can be used in a VCONN through Type-C cable application or two FUSB380Cs can be used in each plug avoiding the high cost of routing VCONN through the Type-C cable. The FUSB380C offers industry leading VCONN operating range down to 2.4 V.

Features

- Integrated USB-PD 3.0 Protocol Layer and Device Policy Engines
- 5x Programmable for Different Cable Configurations
- USB PD 2.0 and 3.0 Certified
- Robust Design Features:
 - ◆ 28 V Tolerant CC and VCONN
 - ◆ Integrated Isolation Between VCONN1 and VCONN2
 - ◆ 2.4 V – 5.5 V VCONN Operation
- Field Programmable for Different Cable Configurations
- SOP' Signaling Support
- Automatic Ra Weakening to Reduce Power Consumption
- 12 Pin WLCSP (1.21 mm x 1.67 mm)
- These Devices are Pb-Free, Halogen Free/BFR Free and are RoHS Compliant

Applications

- Passive Cables



ON Semiconductor®

www.onsemi.com

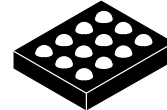

**WLCSP12
CASE 567VZ**

MARKING DIAGRAM

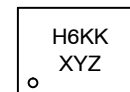

H6 = Two Digit Device Code
KK = Two Digit Lot Run Code (&K)
XY = Two Digit Date Code (&2)
Z = Assembly Plant Code (&Z)

ORDERING INFORMATION

See detailed ordering and shipping information on page 2 of this data sheet.

This document contains information on a product under development. ON Semiconductor reserves the right to change or discontinue this product without notice.

FUSB380C

Table 1. DEVICE ORDERING INFORMATION

Device	Top Marking	Temperature Range	Package	Shipping [†]
FUSB380CUCX	H6	-40°C to +85°C	WLCSP12 (Pb-Free)	3000 / Tape & Reel

[†]For information on tape and reel specifications, including part orientation and tape sizes, please refer to our Tape and Reel Packaging Specifications Brochure, BRD8011/D.

Table 2. 12-BALL WLCSP PIN DESCRIPTION

Pin#	Name	Description
A1	T1	Test Pin – Float
A2	NC	No Connect
A3	GND	Ground
B1	T2	Test Pin – Float
B2	T4	Test Pin – Float
B3	T6	Test Pin – Float
C1	T3	Test Pin – Float
C2	T5	Test Pin – Float
C3	CC	Configuration Channel (28V Tolerant)
D1	VCONN2	VCONN Power (28V Tolerant)
D2	GND	Ground
D3	VCONN1	VCONN Power (28V Tolerant)

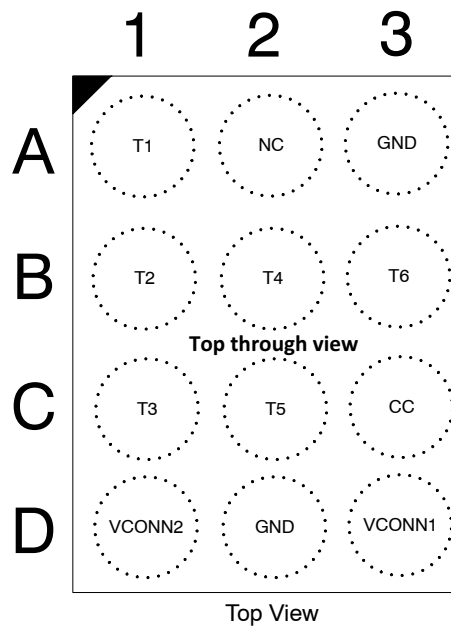

Figure 1. 12-Ball WLCSP Top-Through View

FUSB380C

Table 3. MAXIMUM RATINGS

Symbol	Parameter	Conditions	Min	Typ	Max	Units
V _{CCX}	CC and VCONNx pins (Note 1)		-0.5		28	V
T _J	Maximum Junction Temperature				+150	°C
T _{STORAGE}	Storage Temperature Range		-65		+150	°C
T _L	Lead Temperature (Soldering 10 Seconds) (Note 2)				+260	°C
ESD	Human Body Model, JEDEC JESD22-A114	Connector Pins (CC, VCONNx)	4.5			kV
		Others	2			
	Charged Device Model, JEDEC LESD22-C101	All Pins	2			
Surge	IEC61000-4-5, Surge Protection	Connector Pins (CC, VCONNx)	32			V

Stresses exceeding those listed in the Maximum Ratings table may damage the device. If any of these limits are exceeded, device functionality should not be assumed, damage may occur and reliability may be affected.

1. Refer to ELECTRICAL CHARACTERISTICS, RECOMMENDED OPERATING RANGES and/or APPLICATION INFORMATION for Safe Operating parameters.
2. For information, please refer to our Soldering and Mounting Techniques Reference Manual, SOLDERRM/D

Table 4. RECOMMENDED OPERATING RANGES

Symbol	Parameter	Conditions	Min	Typ	Max	Units
V _{CONNx}	VCONN Voltage (Note 3)		2.4		5.5	V
T _A	Operating Ambient Temperature		-40		+85	°C

Functional operation above the stresses listed in the Recommended Operating Ranges is not implied. Extended exposure to stresses beyond the Recommended Operating Ranges limits may affect device reliability.

3. Programming Voltage range = 4.7 V to 5.5 V

DC AND TRANSIENT ELECTRICAL CHARACTERISTICS (Minimum and maximum values are at VCONNx = 2.4 V to 5.5 V, T_A = -40°C to +85°C unless otherwise noted. Typical values are at T_A = 25°C, VCONNx = 3.3 V)

Symbol	Parameter	Conditions	Min	Typ	Max	Units
--------	-----------	------------	-----	-----	-----	-------

Current Consumption

I _{pd_stby}	BMC PD standby current	VCONN = 2.4 to 5.5 Device attached, BMC PD active but not sending or receiving, Ra weakened. Other VCONN pin floating. CC pulled-up/down/float.			400	μA
----------------------	------------------------	---	--	--	-----	----

BASEBAND PD SYSTEM

UI	Unit Interval		3.03	3.33	3.7	μs
----	---------------	--	------	------	-----	----

TRANSMITTER

P _{BitRate}	Maximum difference between the bit-rate during the payload and last 32 bits of preamble				0.25	%
t _{EndDriveBMC}	Time to cease driving the line after the end of the last bit of the Frame				23	μs
t _{HoldLowBMC}	Time to cease driving the line after the final high-to-low transition		1			μs
t _{StartDrive}	Time before the start of the first bit of the preamble when the transmitter shall start driving the line		-1		1	μs
t _{InterFrameGap}	Any PD transmission cannot be sent out before a dead time of at least t _{InterFrameGap} from receiving or sending a packet		25			μs
t _{Transmit}	GoodCRC response time from last transition following EOP to start of preamble of GoodCRC		25		195	μs
t _{Rise}	Rise Time		300			ns

FUSB380C

DC AND TRANSIENT ELECTRICAL CHARACTERISTICS (Minimum and maximum values are at $V_{CONNx} = 2.4\text{ V}$ to 5.5 V , $T_A = -40^\circ\text{C}$ to $+85^\circ\text{C}$ unless otherwise noted. Typical values are at $T_A = 25^\circ\text{C}$, $V_{CONNx} = 3.3\text{ V}$)

Symbol	Parameter	Conditions	Min	Typ	Max	Units
--------	-----------	------------	-----	-----	-----	-------

TRANSMITTER

t_{Fall}	Fall Time		300			ns
V_{Swing}	BMC voltage swing		1.05	1.125	1.2	V
Z_{Driver}	TX output impedance at 750 kHz with an external 220 pF or equivalent load		33		75	Ω

RECEIVER

$C_{Receiver}$	Receiver capacitance when driver isn't turned on (Note 4)	$V_{rms}=0.371$; $V_{dc}=0.5\text{V}$; $Freq.=1\text{MHz}$		25		pF
Z_{BmcRx}	Receiver Input Impedance (cannot be tested but can be simulated and guaranteed by design)		1			$M\Omega$
$n_{TransitionCount}$	Transitions count in a time window of 20 μs max.		3			edges
$t_{RxFilter}$	Rx bandwidth limiting filter (Note 4)		100			ns
$t_{TransitionWindow}$	Time window for detecting non-idle		12		20	μs

TYPE-C PHY

R_A	Powered Cable Termination before V_{CONN} Power		800		1200	Ω
R_{A_WEAK}	Weakened R_A when V_{CONN} is applied	$V_{CONN} > V_{V_{CONN_RA_WEAK}}$ after $t_{V_{CONN}Stable}$ (min)	18		22	$k\Omega$
Z_{OPEN}	CC resistance when V_{CONNx} is valid and when $V_{CONNx} = 0\text{ V}$		126			$k\Omega$

USB PD SPECIFIC TIMING PARAMETERS

$t_{BISTContMode}$	BIST Carrier Mode 2 pattern sent only for this length of time		30		60	ms
$t_{Transmit}$	From receiving a packet, we have to send a GoodCRC in response within $t_{Transmit}$ time. It is measured from the last bit of the EOP of the received packet to the first bit sent of the preamble of the GoodCRC packet				195	μs

CABLE MARKER SPECIFIC

$t_{V_{CONN}Stable}$	The time between the application of V_{CONN} until SOP' and SOP'' shall be ready for communication.	$V_{CONN} \geq 2.4\text{ V}$	10		50	ms
$V_{V_{CONN_RA_WEAK}}$	Voltage threshold when R_{A_WEAK} is presented after $t_{V_{CONN}Stable}$				2.4	V
$t_{V_{CONN}Discharge}$	The time from the point that the cable is detached until $v_{V_{CONN}Discharge}$ shall be met.	Cable loading = 10 μF , R_{A_WEAK}			230	ms
$V_{V_{CONN}Discharge}$	The V_{CONN} voltage following cable detach and self-discharge.				800	mV
$V_{V_{CONN}Disconnect}$	Threshold used to detect V_{CONN} disconnect.		0.8		2.4	V

Product parametric performance is indicated in the Electrical Characteristics for the listed test conditions, unless otherwise noted. Product performance may not be indicated by the Electrical Characteristics if operated under different conditions.

4. Guaranteed by Design. Characterized on the ATE or Bench.

FUSB380C

Product Block Diagram

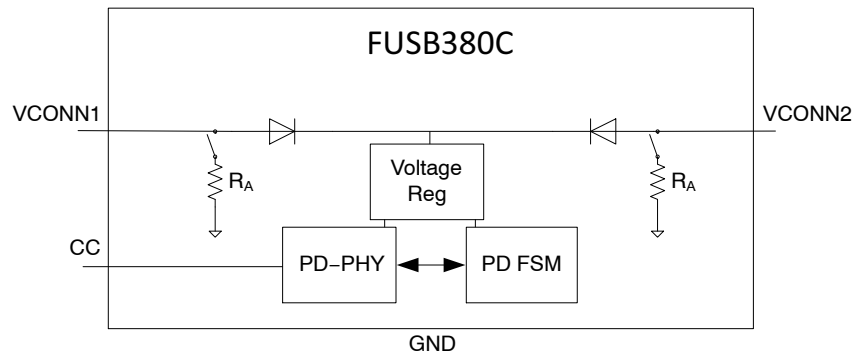

Figure 2. Block Diagram

Application Diagrams

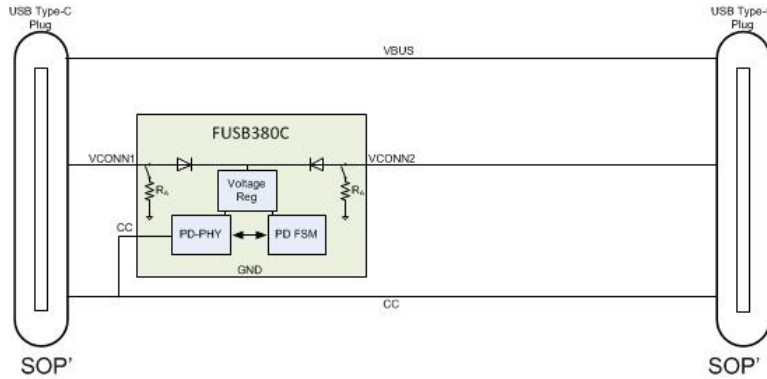

Figure 3. One eMarker and VCONN Through Cable

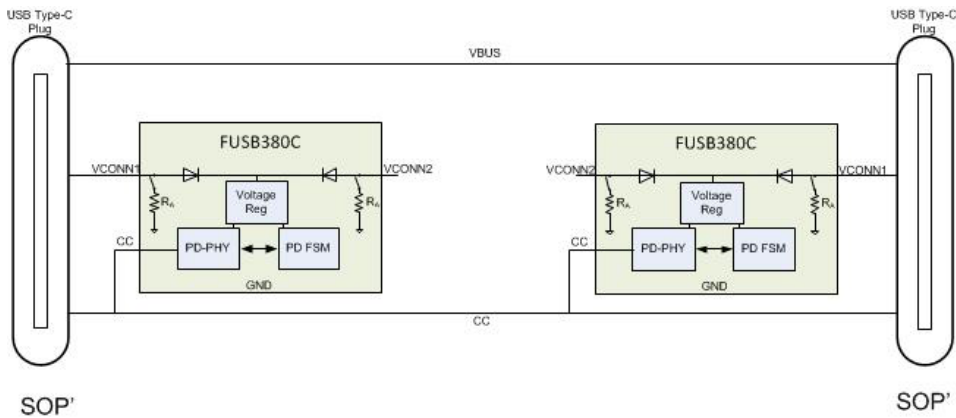

Figure 4. Two eMarkers, no VCONN Through Cable

FUSB380C

Functional Behaviour

VCONN Terminations

The FUSB380C device presents a R_A termination whenever the VCONNx pins are unpowered. Only the VCONNx pin that has a voltage in the valid range for $t_{VCONNStable}$ will be weakened to R_{A_WEAK} .

The function of R_{A_WEAK} is to discharge the voltage on VCONN to $V_{VCONNDischarge}$ within a maximum time of $t_{VCONNDischarge}$ and a maximum load of 10 μ F. The R_{A_WEAK} termination will be applied until VCONN voltage drops below the $V_{RARereconnect}$ threshold. Once this threshold is crossed R_A is reapplied.

Field Programmable Function

The FUSB380C can be programmed by the customer via Vendor Defined Messages. The user can re-program the device a maximum of 5 times.

The device's Discover Identity response can be fully customized for Passive cables, with or without Modal support.

The FUSB380C also offers the ability to program a Serial Number that can be read via a VDM Specific command.

Table 5. SUMMARY OF FIELD PROGRAMMABLE BITS

Parameter	Description	# of Bits
ID HEADER		
MEM_USB_HOST		1
MEM_USB_DEV		1
MEM_PROD_TYPE	Product Type	3
MEM_MODAL	Modal Operation	1
MEM_ID_RSVD_B25_23	Reserved	3
MEM_ID_RSVD_B22_16	Reserved	7
MEM_VID	USB Vendor ID	16
CERTIFICATION STATUS VDO		
MEM_XID	XID	32
PRODUCT VDO		
MEM_USB ID	USB PID	16
MEM_bcdDevice	bcdDevice	16
CABLE VDO		
MEM_HW_VER	Hardware Version	4
MEM_FW_VER	Firmware Version	4
MEM_VDO_VER		3
MEM_CABLE_RSVD_B20	Reserved	1
MEM_TYPEC_TO_X	USB Type-C to X	2
MEM_CABLE_RSVD_B17	Reserved	1
MEM_LATENCY	Cable Latency	4
MEM_TERM_TYPE	Cable Termination Type	2
MEM_CABLE_VDO_BIT10_9	Max VBUS V	2
MEM_CABLE_VDO_BIT8_7	SS Direction	2
MEM_VBUS_AMPS	VBUS Current Handling	2
MEM_VBUS_THROUGH	VBUS Through Cable	1
MEM_SOP2	SOP2 Present	1
MEM_SS_SIG	USB SS Signaling	3
DISCOVER SVID RESPONSE		
SVID0	SVID0 = VID	0
MEM_SVID1	SVID1	16
DISCOVER MODES VDO		
MEM_VDO_SVID0		32
MEM_VDO_SVID1	Mode VDO for SVID1 (Alternate Mode)	32

FUSB380C

Table 5. SUMMARY OF FIELD PROGRAMMABLE BITS

Parameter	Description	# of Bits
SERIAL NUMBERS		
MEM_CABLE_SN	Cable Serial Number	136
MEM_SN_SVID	Serial numbers replied in SVIDx 0 = SVID0 1 – SVID1	1
MEM_SN_COMMAND	Customer Serial Number SVID specific command	5
MEM_DIESN_COMMAND	Die Serial Number SVID specific command	5



WLCSP12, 1.21x1.67x0.586
CASE 567VZ
ISSUE O

DATE 09 FEB 2018

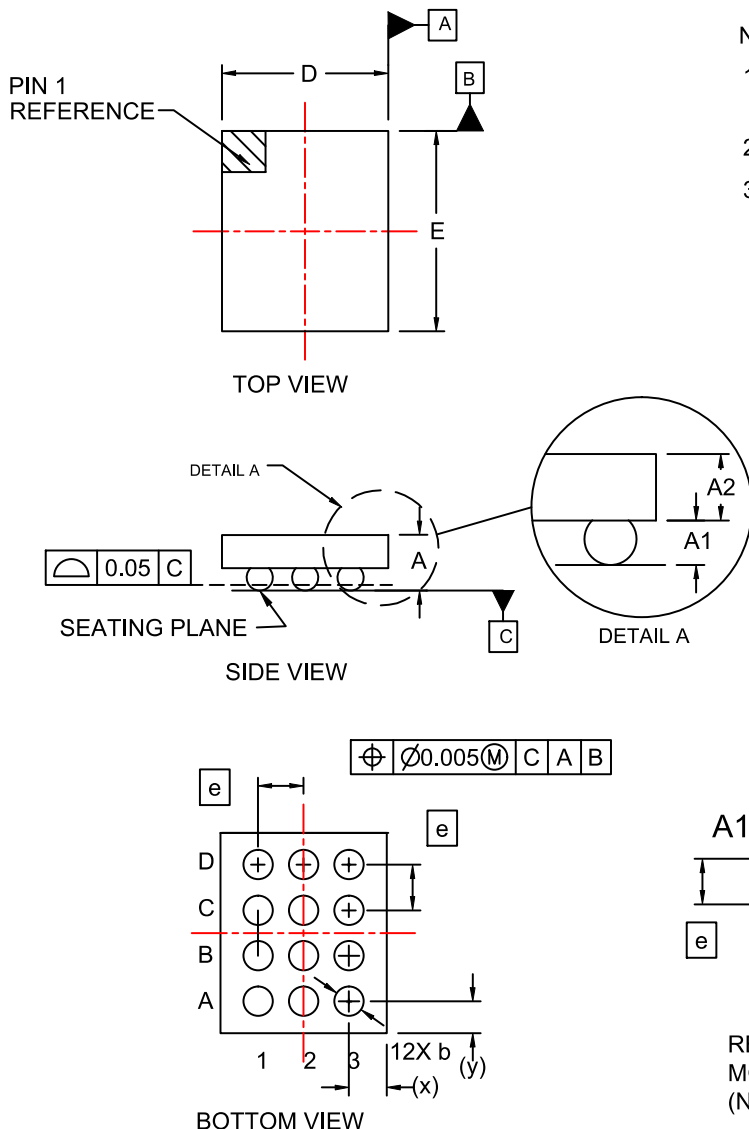

NOTES:

1. DIMENSIONING AND TOLERANCING PER ASME Y14.5M, 2009.
2. CONTROLLING DIMENSION: MILLIMETERS
3. DATUM C APPLIES TO THE SPHERICAL CROWN OF THE SOLDER BALLS

DIM	MILLIMETERS		
	MIN.	NOM.	MAX.
A	.536	.574	.612
A1	.176	.196	.216
A2	.360	.378	.396
b	.240	.260	.280
D	1.18	1.21	1.24
E	1.64	1.67	1.70
e	0.40 BSC		
x	0.190	0.205	0.220
y	0.220	0.235	0.250

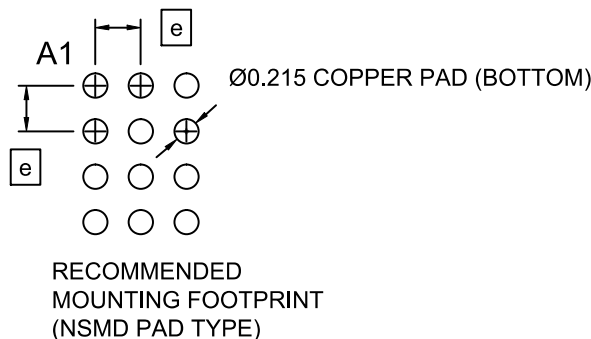

DOCUMENT NUMBER:	98AON83933G	Electronic versions are uncontrolled except when accessed directly from the Document Repository. Printed versions are uncontrolled except when stamped "CONTROLLED COPY" in red.
DESCRIPTION:	WLCSP12, 1.21X1.67X0.586	PAGE 1 OF 1

ON Semiconductor and are trademarks of Semiconductor Components Industries, LLC dba ON Semiconductor or its subsidiaries in the United States and/or other countries. ON Semiconductor reserves the right to make changes without further notice to any products herein. ON Semiconductor makes no warranty, representation or guarantee regarding the suitability of its products for any particular purpose, nor does ON Semiconductor assume any liability arising out of the application or use of any product or circuit, and specifically disclaims any and all liability, including without limitation special, consequential or incidental damages. ON Semiconductor does not convey any license under its patent rights nor the rights of others.

onsemi, **Onsemi**, and other names, marks, and brands are registered and/or common law trademarks of Semiconductor Components Industries, LLC dba "**onsemi**" or its affiliates and/or subsidiaries in the United States and/or other countries. **onsemi** owns the rights to a number of patents, trademarks, copyrights, trade secrets, and other intellectual property. A listing of **onsemi**'s product/patent coverage may be accessed at www.onsemi.com/site/pdf/Patent-Marking.pdf. **onsemi** reserves the right to make changes at any time to any products or information herein, without notice. The information herein is provided "as-is" and **onsemi** makes no warranty, representation or guarantee regarding the accuracy of the information, product features, availability, functionality, or suitability of its products for any particular purpose, nor does **onsemi** assume any liability arising out of the application or use of any product or circuit, and specifically disclaims any and all liability, including without limitation special, consequential or incidental damages. Buyer is responsible for its products and applications using **onsemi** products, including compliance with all laws, regulations and safety requirements or standards, regardless of any support or applications information provided by **onsemi**. "Typical" parameters which may be provided in **onsemi** data sheets and/or specifications can and do vary in different applications and actual performance may vary over time. All operating parameters, including "Typicals" must be validated for each customer application by customer's technical experts. **onsemi** does not convey any license under any of its intellectual property rights nor the rights of others. **onsemi** products are not designed, intended, or authorized for use as a critical component in life support systems or any FDA Class 3 medical devices or medical devices with a same or similar classification in a foreign jurisdiction or any devices intended for implantation in the human body. Should Buyer purchase or use **onsemi** products for any such unintended or unauthorized application, Buyer shall indemnify and hold **onsemi** and its officers, employees, subsidiaries, affiliates, and distributors harmless against all claims, costs, damages, and expenses, and reasonable attorney fees arising out of, directly or indirectly, any claim of personal injury or death associated with such unintended or unauthorized use, even if such claim alleges that **onsemi** was negligent regarding the design or manufacture of the part. **onsemi** is an Equal Opportunity/Affirmative Action Employer. This literature is subject to all applicable copyright laws and is not for resale in any manner.

PUBLICATION ORDERING INFORMATION

LITERATURE FULFILLMENT:

Email Requests to: orderlit@onsemi.com

onsemi Website: www.onsemi.com

TECHNICAL SUPPORT

North American Technical Support:

Voice Mail: 1 800-282-9855 Toll Free USA/Canada

Phone: 011 421 33 790 2910

Europe, Middle East and Africa Technical Support:

Phone: 00421 33 790 2910

For additional information, please contact your local Sales Representative