

# High-Current, High & Low-Side, Gate-Driver IC

## FAN73912A

### Description

The FAN73912A is a monolithic high and low-side gate-drive IC designed for high-voltage and high-speed driving for MOSFETs and IGBTs that operate up to +1200 V.

The advanced input filter of HIN provides protection against short-pulsed input signals caused by noise.

An advanced level-shift circuit offers high-side gate driver operation up to  $V_S = -9.8$  V (typical) for  $V_{BS} = 15$  V. The UVLO circuit prevents malfunction when VCC and VBS are lower than the specified threshold voltage.

Output drivers typically source and sink 2 A and 3 A, respectively.

### Features

- Floating Channel for Bootstrap Operation to +1200 V
- Typically 2 A/ 3 A Sourcing/Sinking Current Driving Capability for Both Channels
- Gate Driver Supply (VCC) Range from 12 V to 20 V
- Separate Logic Supply (VDD) Range from 3 V to 20 V
- Extended Allowable Negative  $V_S$  Swing to -9.8 V for Signal Propagation at  $V_{CC} = V_{BS} = 15$  V
- Built-in Cycle-by-Cycle Edge-Triggered Shutdown Logic
- Common-Mode  $dv/dt$  Noise Canceling Circuit
- UVLO Functions for Both Channels
- Built-in Advanced Input Filter
- Matched Propagation Delay Below 60 ns
- Outputs in-Phase with Input Signal
- Logic and Power Ground  $\pm 10$  V Offset

### Typical Application

- Electrical Contactor
- Industrial Motor Driver
- UPS
- Solar Inverter
- Ballast
- General-Purpose Half-Bridge Topology



ON Semiconductor®

[www.onsemi.com](http://www.onsemi.com)



SOIC-16  
CASE 751BH

### MARKING DIAGRAM

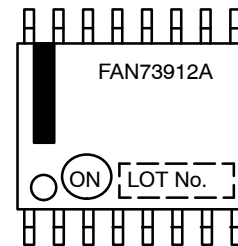

### ORDERING INFORMATION

Device	Package	Shipping†
FAN73912AMX (Note 1)	Wide-16 SOIC	1,000/ Tape & Reel

†For information on tape and reel specifications, including part orientation and tape sizes, please refer to our Tape and Reel Packaging Specification Brochure, BRD8011/D.

1. This device passed wave-soldering test by JESD22A-111

# FAN73912A

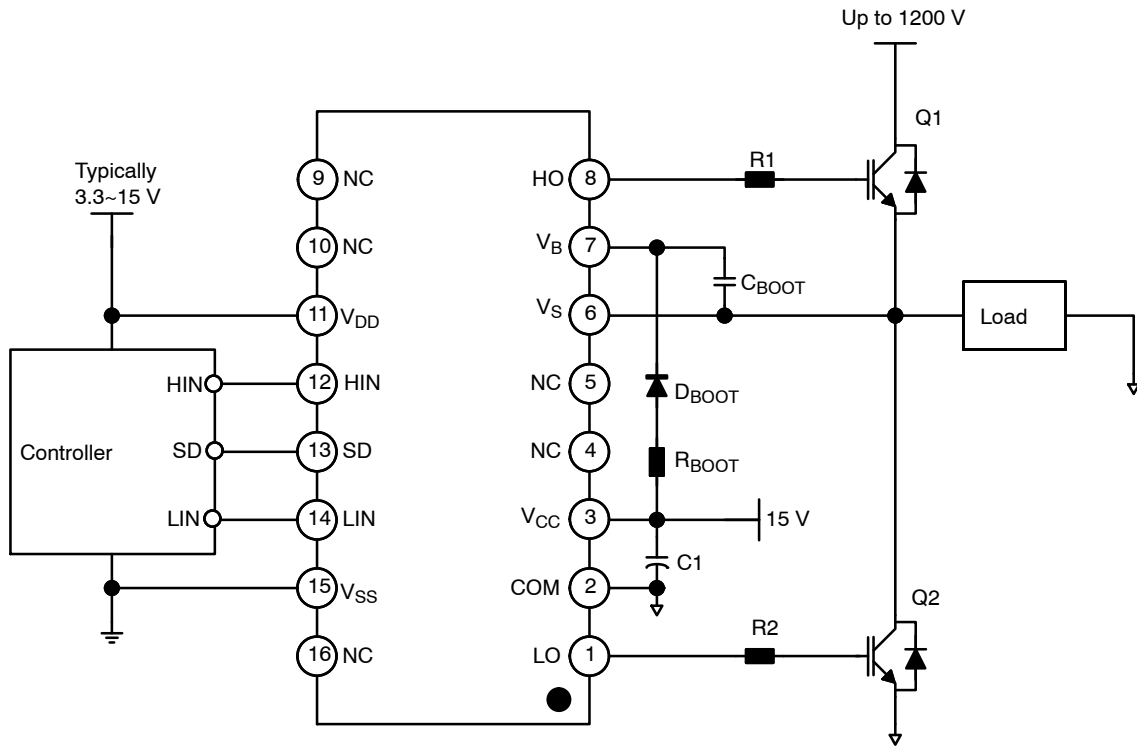

Figure 1. Application Schematic – Adjustable Option

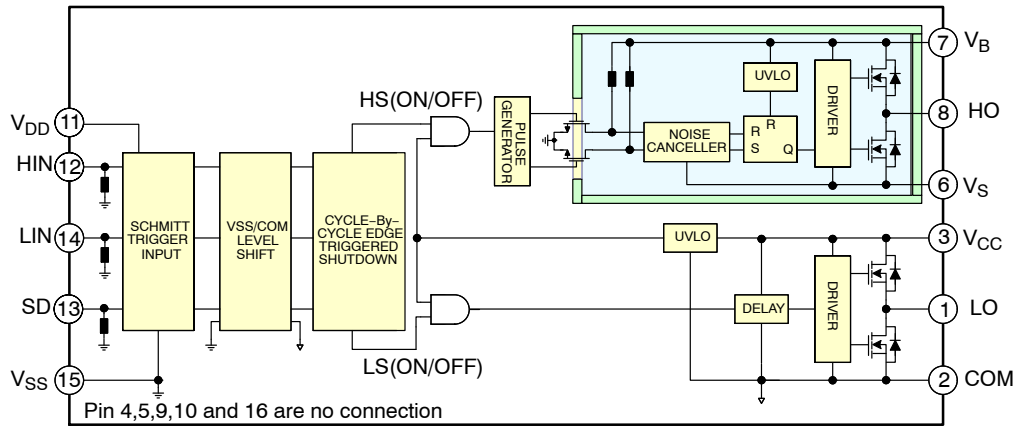
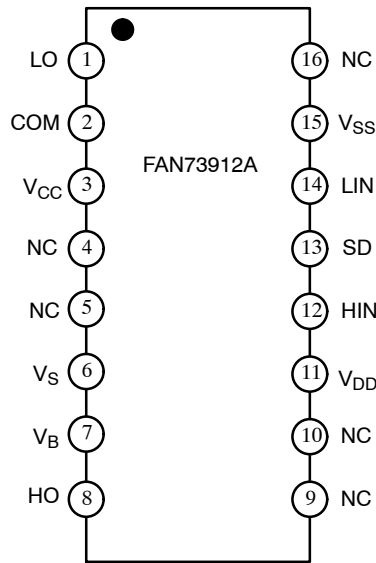

Figure 2. Simplified Block Diagram

## FAN73912A



**Figure 3. Pin Connections – Wide 16-SOIC  
(Top View)**

**Table 1. PIN FUNCTION DESCRIPTION** (Note 2)

Pin No.	Symbol	Description
1	LO	Low-Side Driver Output
2	COM	Low-Side Driver Return
3	VCC	Low-Side Supply Voltage
4	NC	No Connection
5	NC	No Connection
6	V <sub>S</sub>	High-Voltage Floating Supply Return
7	V <sub>B</sub>	High-Side Floating Supply
8	HO	High-Side Driver Output
9	NC	No Connection
10	NC	No Connection
11	V <sub>DD</sub>	Logic Supply Voltage
12	HIN	Logic Input for High-Side Gate Driver Output
13	SD	Logic Input for Shutdown
14	LIN	Logic Input for Low-Side Gate Driver Output
15	V <sub>SS</sub>	Logic Ground
16	NC	No Connection

2. Do not connect NC pins to ground or any other nodes in the circuitry to ensure floating status.

## FAN73912A

**Table 2. MAXIMUM RATINGS** ( $T_J = 25^\circ\text{C}$ , unless otherwise specified. All voltage parameters are referenced to COM unless otherwise stated in the table.)

Symbol	Parameter	Min	Max	Unit
$V_B$	High-Side Floating Supply Voltage	-0.3	1225.0	V
$V_S$	High-Side Floating Offset Voltage	$T_J = 150^\circ\text{C}$ $T_J = 25^\circ\text{C}$ $T_J = -40^\circ\text{C}$	$V_B + 0.3$ $V_B + 0.3$ $V_B + 0.3$	V
$V_{HO}$	High-Side Floating Output Voltage	$V_S - 0.3$	$V_B + 0.3$	V
$V_{CC}$	Low-Side Supply Voltage	-0.3	25	V
$V_{LO}$	Low-Side Floating Output Voltage	-0.3	$V_{CC} + 0.3$	V
$V_{DD}$	Logic Supply Voltage	-0.3 $V_{SS} - 0.3$	25 $V_{SS} + 25$	V
$V_{SS}$	Logic GND	$V_{DD} - 25$	$V_{DD} + 0.3$	V
$V_{IN}$	Logic Input Voltage (HIN, LIN and SD)	-0.3 $V_{SS} + V_{DD} - 25.3$	25 $V_{DD} + 0.3$	V
$dV_S/dt$	Allowable Offset Voltage Slew Rate	-	$\pm 50$	V/ns
$P_D$ (Note 3, 4, 5)	Power Dissipation	-	1.3	W
$\theta_{JA}$	Thermal Resistance	-	95	$^\circ\text{C}/\text{W}$
$T_J$	Junction Temperature	-	150	$^\circ\text{C}$
$T_{STG}$	Storage Temperature	-55	150	$^\circ\text{C}$

Stresses exceeding those listed in the Maximum Ratings table may damage the device. If any of these limits are exceeded, device functionality should not be assumed, damage may occur and reliability may be affected.

3. Mounted on 76.2 x 114.3 x 1.6 mm PCB (FR-4 glass epoxy material).

4. Refer to the following standards:

JESD51-2: Integral circuit's thermal test method environmental conditions, natural convection;

JESD51-3: Low effective thermal conductivity test board for leaded surface-mount packages.

5. Do not exceed maximum power dissipation ( $P_D$ ) under any circumstances.

**Table 3. RECOMMENDED OPERATING CONDITIONS** (All voltage parameters are referenced to COM unless otherwise stated in the table.)

Symbol	Parameter	Min	Max	Unit
$V_B$	High-Side Floating Supply Voltage	$V_S + 12$	$V_S + 20$	V
$V_S$	High-Side Floating Supply Offset Voltage (Note 6)	$8 - V_{CC}$	1200	V
$V_{HO}$	High-Side (HO) Output Voltage	$V_S$	$V_B$	V
$V_{CC}$	Low-Side Supply Voltage	12	20	V
$V_{LO}$	Low-Side (LO) Output Voltage	0	$V_{CC}$	V
$V_{DD}$	Logic Supply Voltage	$V_{SS} + 3$	$V_{SS} + 20$	V
$V_{SS}$	Logic Ground (Note 7)	-10	10	V
$V_{IN}$	Logic Input Voltage (HIN, LIN, SD)	0 $V_{SS} + V_{DD} - 20$	20 $V_{DD}$	V
$T_J$	Junction Temperature	-40	+125	$^\circ\text{C}$

Functional operation above the stresses listed in the Recommended Operating Ranges is not implied. Extended exposure to stresses beyond the Recommended Operating Ranges limits may affect device reliability.

6. Referenced to  $T_J = 25^\circ\text{C}$ .

7. When  $V_{DD} < 10$  V, the minimum  $V_{SS}$  offset is limited to  $-V_{DD}$ .

# FAN73912A

**Table 4. STATIC ELECTRICAL CHARACTERISTICS** ( $V_{BIAS}$  ( $V_{CC}$ ,  $V_{BS}$ ,  $V_{DD}$ ) = 15.0 V,  $T_J$  =  $-40^{\circ}\text{C}$  to  $125^{\circ}\text{C}$ , unless otherwise specified. The  $V_{IH}$ ,  $V_{IL}$  and  $I_{IN}$  parameters are referenced to  $V_{SS}$  and are applicable to respective input leads: HIN, LIN and SD. The  $V_O$  and  $I_O$  parameters are referenced to  $V_S$  and COM and are applicable to the respective output leads: HO and LO. The  $V_{DDUV}$  parameters are referenced to COM. The  $V_{BSUV}$  parameters are referenced to  $V_{S1, 2, 3}$ )

Symbol	Parameter	Conditions	Min	Typ	Max	Units	
<b>LOW-SIDE POWER SUPPLY SECTION</b>							
$I_{QCC}$	Quiescent $V_{CC}$ Supply Current	$V_{IN} = 0\text{ V or }V_{DD}$	$T_J = 25^{\circ}\text{C}$	–	170	300	$\mu\text{A}$
			$T_J = -40^{\circ}\text{C to }125^{\circ}\text{C}$	–	170	350	
$I_{QDD}$	Quiescent $V_{DD}$ Supply Current	$V_{IN} = 0\text{ V or }V_{DD}$	$T_J = 25^{\circ}\text{C}$	–	–	10	$\mu\text{A}$
			$T_J = -40^{\circ}\text{C to }125^{\circ}\text{C}$	–	–	20	
$I_{PCC}$	Operating $V_{CC}$ Supply Current	$f_{IN} = 20\text{ kHz, rms }V_{IN} = 15\text{ V}_{PP}$	–	650	950	$\mu\text{A}$	
$I_{PDD}$	Operating $V_{DD}$ Supply Current	$f_{IN} = 20\text{ kHz, rms }V_{IN} = 15\text{ V}_{PP}$	–	2	–		
$I_{SD}$	Shutdown Supply Current	$S_D = V_{DD}$	–	30	50	$\mu\text{A}$	
$V_{CCUV+}$	$V_{CC}$ Supply Under-Voltage Positive-Going Threshold Voltage	$V_{CC} = \text{Sweep}$	9.7	11.0	12	V	
$V_{CCUV-}$	$V_{CC}$ Supply Under-Voltage Negative-Going Threshold Voltage	$V_{CC} = \text{Sweep}$	9.2	10.5	11.4	V	
$V_{CCUVH}$	$V_{CC}$ Supply Under-Voltage Lockout Hysteresis Voltage	$V_{CC} = \text{Sweep}$	–	0.5	–	V	
<b>BOOTSTRAPPED SUPPLY SECTION</b>							
$I_{QBS}$	Quiescent $V_{BS}$ Supply Current	$V_{IN} = 0\text{ V or }V_{DD}$	–	50	100	$\mu\text{A}$	
$I_{PBS}$	Operating $V_{BS}$ Supply Current	$f_{IN} = 20\text{ kHz, rms value}$	–	550	850	$\mu\text{A}$	
$V_{BSUV+}$	$V_{BS}$ Supply Under-Voltage Positive-Going Threshold Voltage	$V_{BS} = \text{Sweep}$	9.7	11.0	12.0	V	
$V_{BSUV-}$	$V_{BS}$ Supply Under-Voltage Negative-Going Threshold Voltage	$V_{BS} = \text{Sweep}$	9.2	10.5	11.4	V	
$V_{BSUVH}$	$V_{BS}$ Supply Under-Voltage Lockout Hysteresis Voltage	$V_{BS} = \text{Sweep}$	–	0.5	–	V	
$I_{LK}$	Offset Supply Leakage Current	$V_B = V_S = 1200\text{ V } (T_J = 25^{\circ}\text{C})$	–	–	100	$\mu\text{A}$	
		$V_B = V_S = 1200\text{ V } (T_J = 125^{\circ}\text{C})$ (Note 8)	–	–	100		
		$V_B = V_S = 1000\text{ V } (T_J = -40^{\circ}\text{C})$ (Note 8)	–	–	100		
<b>INPUT LOGIC SECTION (HIN, LIN AND AD)</b>							
$V_{IH}$	Logic "1" Input Voltage	$V_{DD} = 3\text{ V}$	2.4	–	–	V	
		$V_{DD} = 15\text{ V}$	$T_J = 25^{\circ}\text{C}$	9.5	–		–
			$T_J = -40^{\circ}\text{C to }125^{\circ}\text{C}$	10.5	–		–
$V_{IL}$	Logic "0" Input Voltage	$V_{DD} = 3\text{ V}$	–	–	0.8	V	
		$V_{DD} = 15\text{ V}$	$T_J = 25^{\circ}\text{C}$	–	–		6.0
			$T_J = -40^{\circ}\text{C to }125^{\circ}\text{C}$	–	–		9.5
$I_{IN+}$	Logic "1" Input bias Current	$V_{IN} = 15\text{ V}$	–	30	50	$\mu\text{A}$	
$I_{IN-}$	Logic "0" Input bias Current	$V_{IN} = 0\text{ V}$	–	–	1	$\mu\text{A}$	
$R_{IN}$	Logic Input Pull-down Resistance		–	500	–	$\text{k}\Omega$	
<b>GATE DRIVER OUTPUT SECTION</b>							
$V_{OH}$	High-Level Output Voltage, $V_{BIAS}-V_O$	$I_O = 0\text{ A}$	$T_J = 25^{\circ}\text{C}$	–	–	1.2	V
			$T_J = -40^{\circ}\text{C to }125^{\circ}\text{C}$	–	–	1.4	
$V_{OL}$	Low-Level Output Voltage, $V_O$	$I_O = 0\text{ A}$	–	–	0.1	V	

Product parametric performance is indicated in the Electrical Characteristics for the listed test conditions, unless otherwise noted. Product performance may not be indicated by the Electrical Characteristics if operated under different conditions.

8. These parameters are guaranteed by design.

# FAN73912A

**Table 4. STATIC ELECTRICAL CHARACTERISTICS** ( $V_{BIAS} (V_{CC}, V_{BS}, V_{DD}) = 15.0\text{ V}$ ,  $T_J = -40^\circ\text{C}$  to  $125^\circ\text{C}$ , unless otherwise specified. The  $V_{IH}$ ,  $V_{IL}$  and  $I_{IN}$  parameters are referenced to  $V_{SS}$  and are applicable to respective input leads: HIN, LIN and SD. The  $V_O$  and  $I_O$  parameters are referenced to  $V_S$  and COM and are applicable to the respective output leads: HO and LO. The  $V_{DDUV}$  parameters are referenced to COM. The  $V_{BSUV}$  parameters are referenced to  $V_{S1, 2, 3}$ ) (continued)

Symbol	Parameter	Conditions	Min	Typ	Max	Units
<b>GATE DRIVER OUTPUT SECTION</b>						
$I_{O+}$	Output HIGH Short-Circuit Pulse Current	$V_O = 0\text{ V}$ , $V_{IN} = 5\text{ V}$ with $PW \leq 10\ \mu\text{s}$	–	2.0	–	A
$I_{O-}$	Output LOW Short-Circuit Pulsed Current	$V_O = 15\text{ V}$ , $V_{IN} = 0\text{ V}$ with $PW \leq 10\ \mu\text{s}$	–	3.0	–	A
$V_S$	Allowable Negative $V_S$ Pin Voltage for HIN Signal Propagation to HO		–	–9.8	–7.0	V

Product parametric performance is indicated in the Electrical Characteristics for the listed test conditions, unless otherwise noted. Product performance may not be indicated by the Electrical Characteristics if operated under different conditions.

8. These parameters are guaranteed by design.

**Table 5. DYNAMIC ELECTRICAL CHARACTERISTICS** ( $V_{BIAS} (V_{CC}, V_{BS}, V_{DD}) = 15.0\text{ V}$ ,  $V_S = V_{SS} = \text{COM}$ ,  $C_L = 1000\text{ pF}$  and  $T_J = -40^\circ\text{C}$  to  $125^\circ\text{C}$ , unless otherwise specified.)

Symbol	Parameter	Conditions	Min	Typ	Max	Units	
<b>LOW-SIDE POWER SUPPLY SECTION</b>							
$t_{ON}$	Turn-On Propagation Delay	$V_S = 0\text{ V}$	–	500	–	ns	
$t_{OFF}$	Turn-Off Propagation Delay	$V_S = 0\text{ V}$	–	550	–	ns	
$t_{FLTIN}$	Input Filtering Time (HIN, LIN) (Note 9)	$T_J = 25^\circ\text{C}$	80	150	220	ns	
		$T_J = -40^\circ\text{C}$ to $125^\circ\text{C}$	80	150	300		
$t_{FLTS}$	Input Filtering Time (SD)		–	30	–	ns	
$t_{SD}$	Shutdown Propagation Delay Time	$T_J = 25^\circ\text{C}$	260	330	400	ns	
		$T_J = -40^\circ\text{C}$ to $125^\circ\text{C}$	200	330	550		
$t_R$	Turn-On Rise Time		–	25	–	ns	
$t_F$	Turn-Off Fall Time		–	15	–		
MT	Delay Matching , HO & LO Turn-On/OFF (Note 10)	$T_J = 25^\circ\text{C}$	–	–	50	ns	
		$T_J = -40^\circ\text{C}$ to $125^\circ\text{C}$	–	–	60		
PM	Output Pulse-Width Matching (Note 11)	$PW_{IN} > 1\ \mu\text{s}$	$T_J = 25^\circ\text{C}$	–	50	100	ns
			$T_J = -40^\circ\text{C}$ to $125^\circ\text{C}$	–	50	140	

Product parametric performance is indicated in the Electrical Characteristics for the listed test conditions, unless otherwise noted. Product performance may not be indicated by the Electrical Characteristics if operated under different conditions.

9. The minimum width of the input pulse should exceed 500 ns to ensure the filtering time of the input filter is exceeded.

10. MT is defined as an absolute value of matching delay time between High-side and Low-Side.

11. PM is defined as an absolute value of matching pulse-width between Input and Output.

# FAN73912A

## TYPICAL CHARACTERISTICS

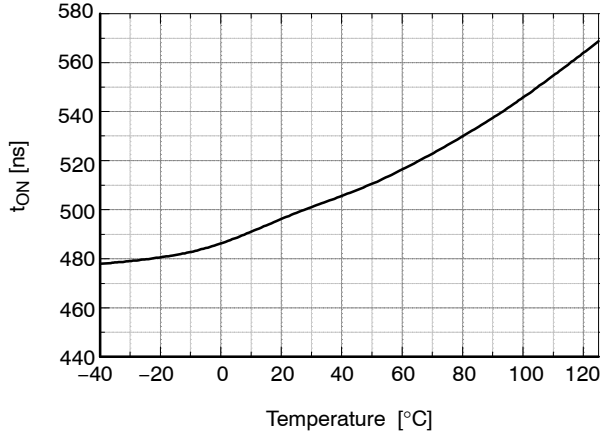

Figure 4. Turn-On Propagation Delay vs. Temperature

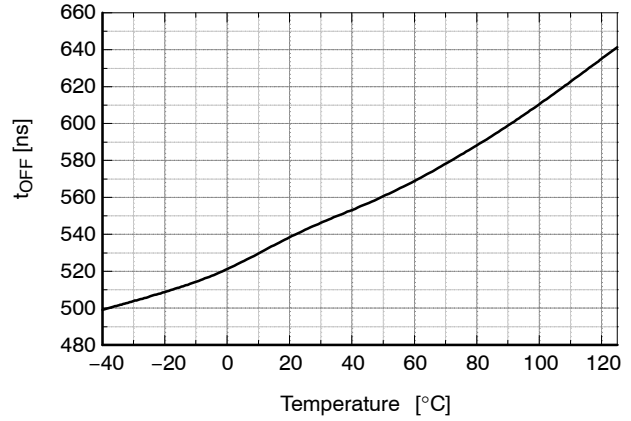

Figure 5. Turn-Off Propagation Delay vs. Temperature

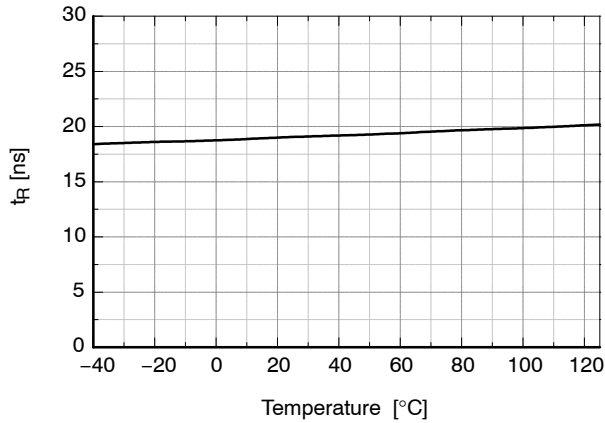

Figure 6. Turn-On Rise Time vs Temperature

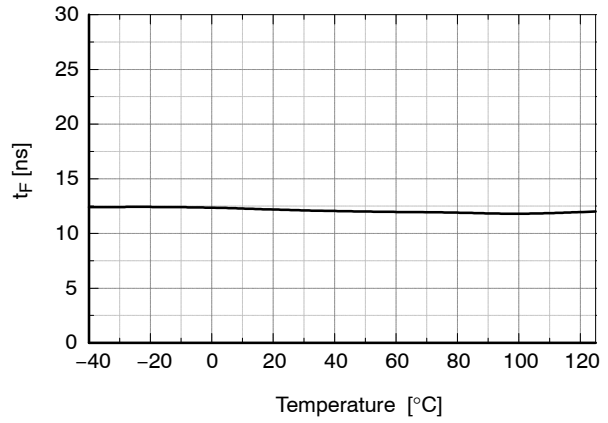

Figure 7. Turn-Off Fall Time vs. Temperature

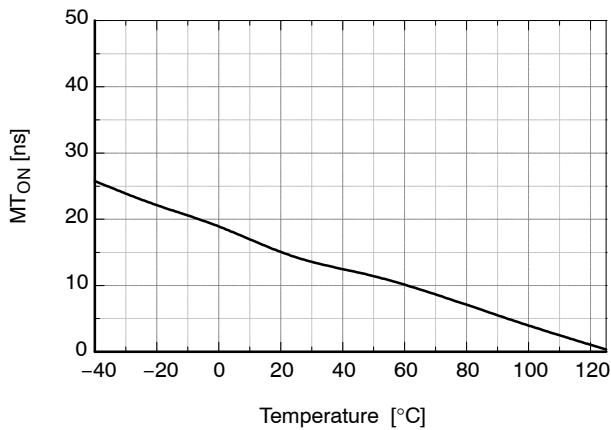

Figure 8. Turn-On Delay Matching vs. Temperature

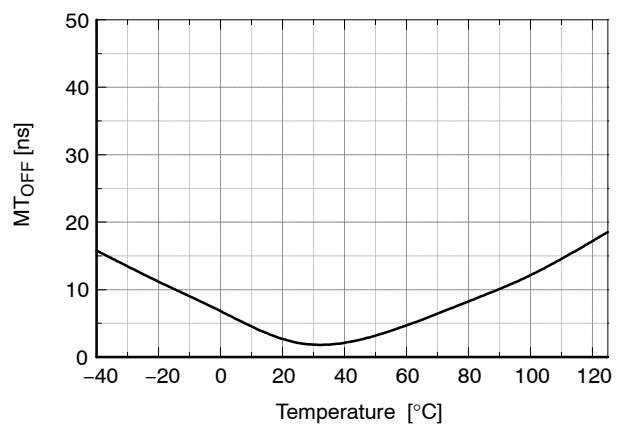

Figure 9. Turn-Off Delay Matching vs. Temperature

TYPICAL CHARACTERISTICS (continued)

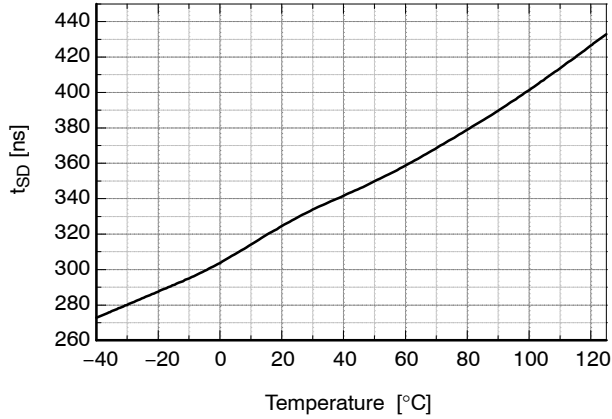

Figure 10. Shutdown Propagation Delay vs. Temperature

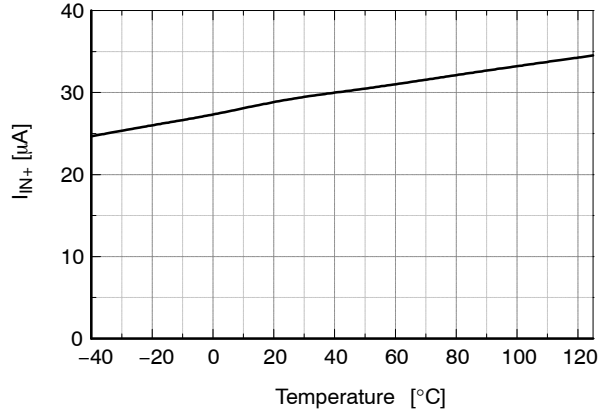

Figure 11. Logic Input High Bias Current vs. Temperature

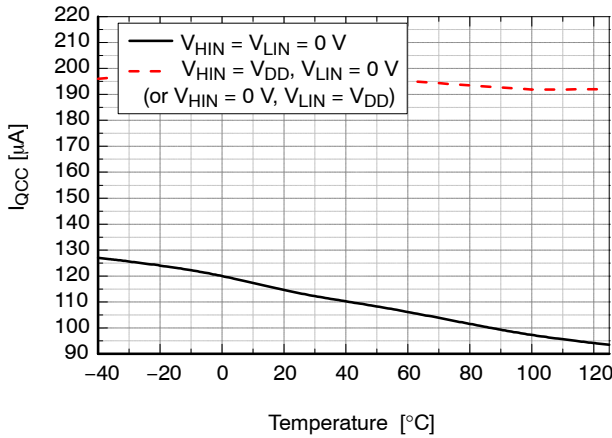

Figure 12. Quiescent V<sub>CC</sub> Supply Current

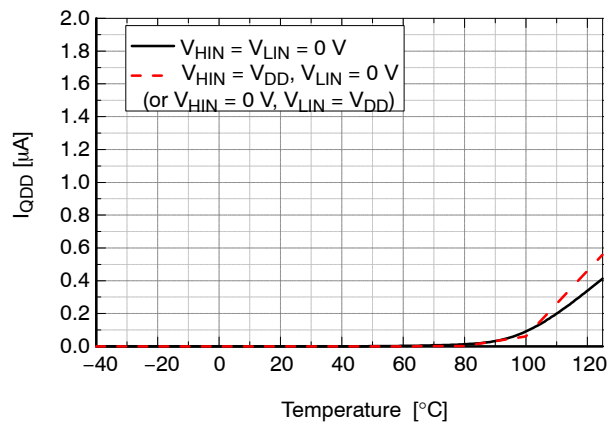

Figure 13. Quiescent V<sub>DD</sub> Supply Current vs. Temperature

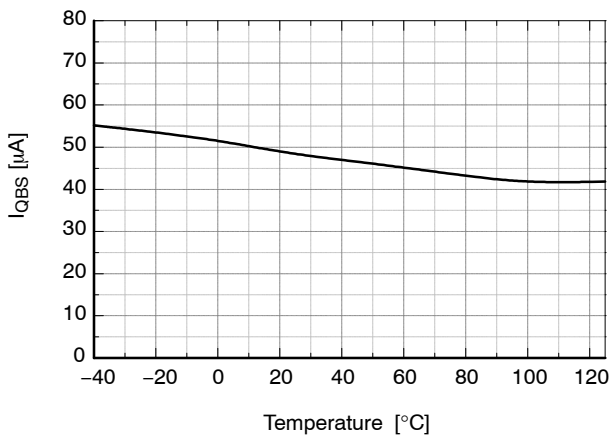

Figure 14. Quiescent V<sub>BS</sub> Supply Current

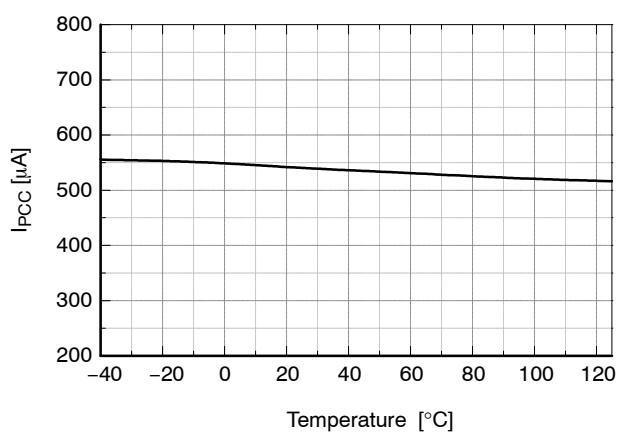

Figure 15. Operating V<sub>CC</sub> Supply Current



TYPICAL CHARACTERISTICS (continued)

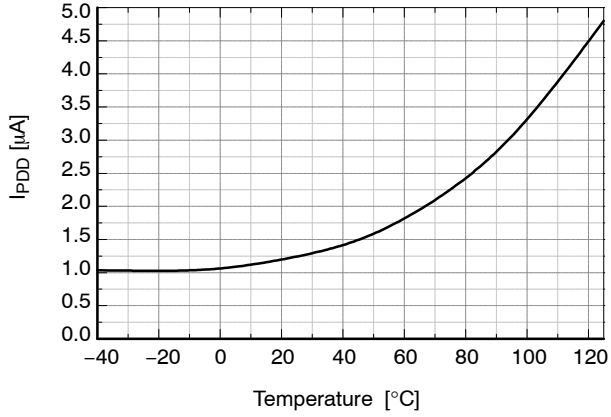

Figure 16. Operating V<sub>DD</sub> Supply Current

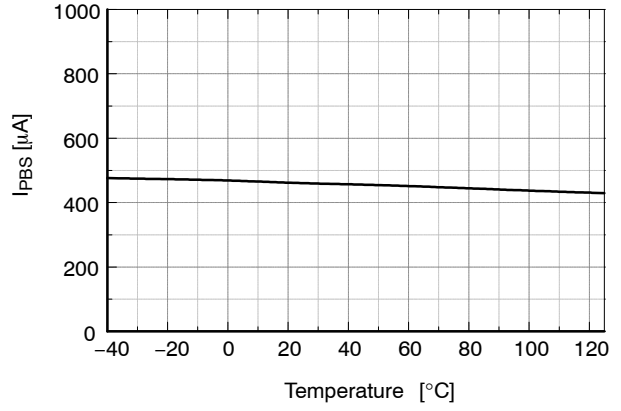

Figure 17. Operating V<sub>BS</sub> Supply Current vs. Temperature

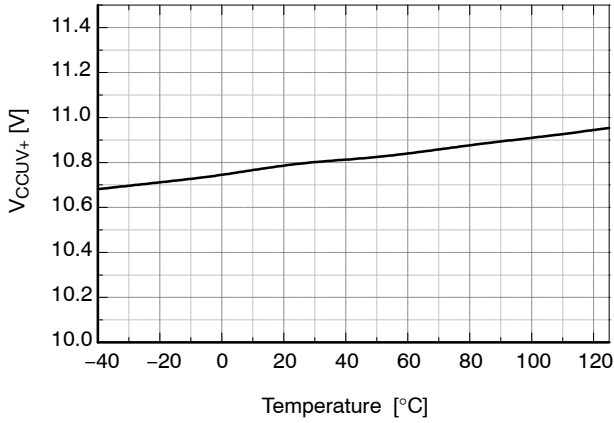

Figure 18. V<sub>CC</sub> UVLO+ vs. Temperature

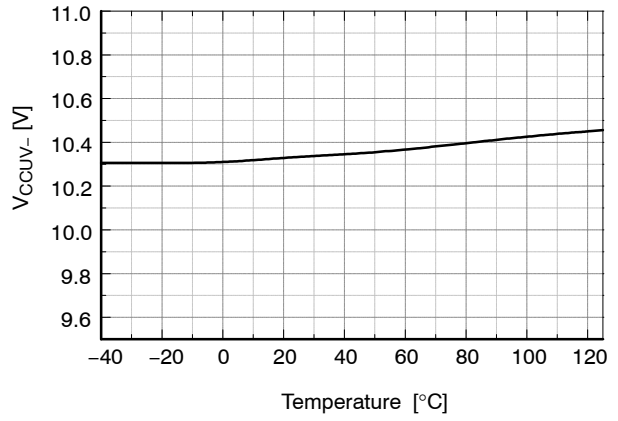

Figure 19. V<sub>CC</sub> UVLO- vs. Temperature

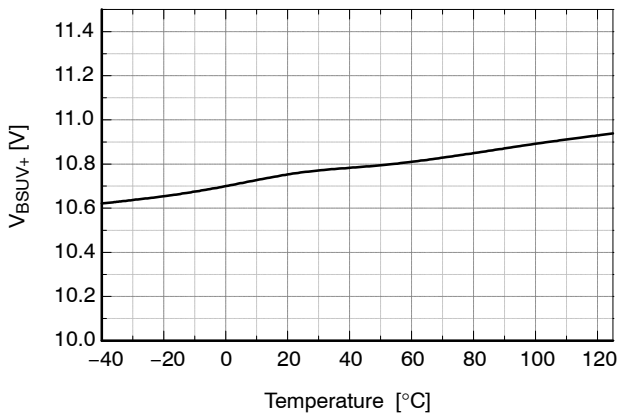

Figure 20. V<sub>BS</sub> UVLO+ vs. Temperature

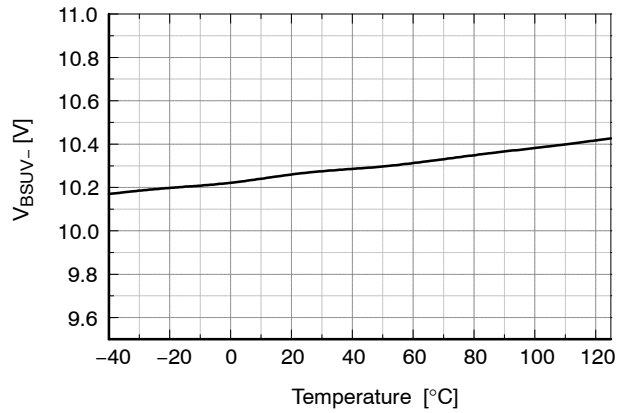

Figure 21. V<sub>BS</sub> UVLO- vs. Temperature

TYPICAL CHARACTERISTICS (continued)

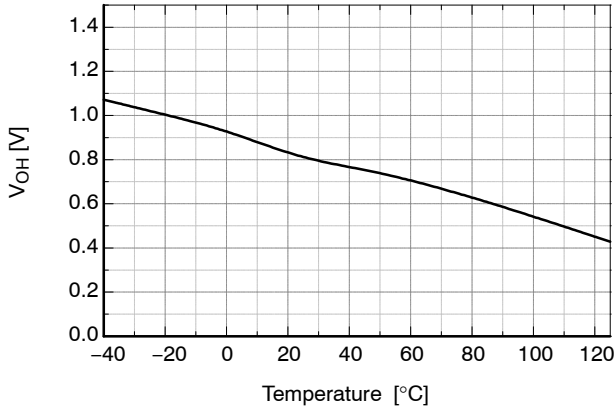

Figure 22. High-Level Output Voltage

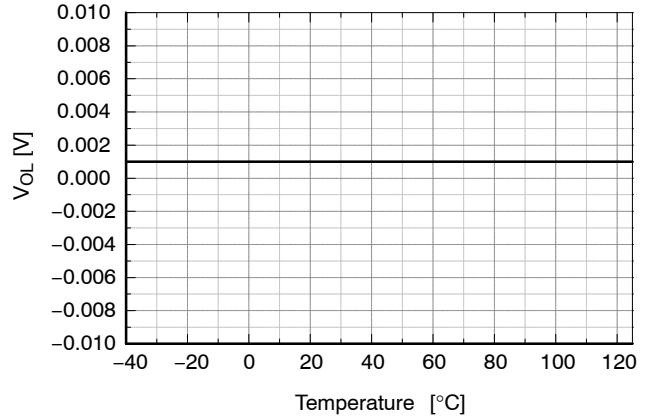

Figure 23. Low-Level Output Voltage vs. Temperature

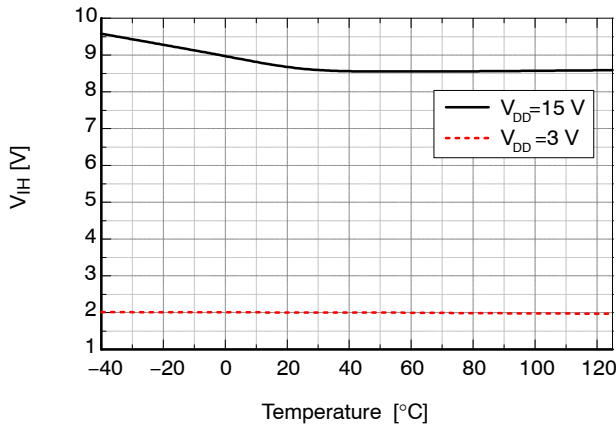

Figure 24. Logic High Input Voltage

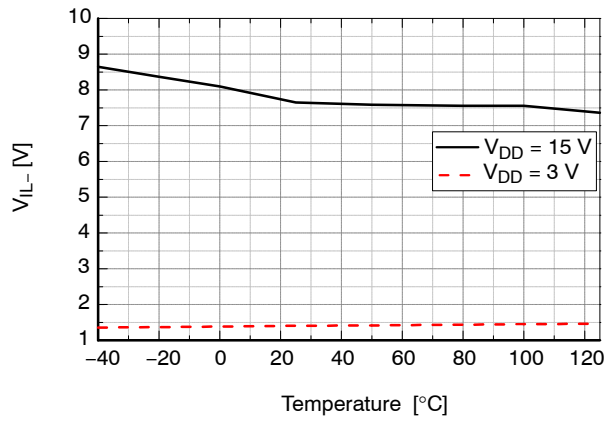

Figure 25. Logic Low Input Voltage vs. Temperature

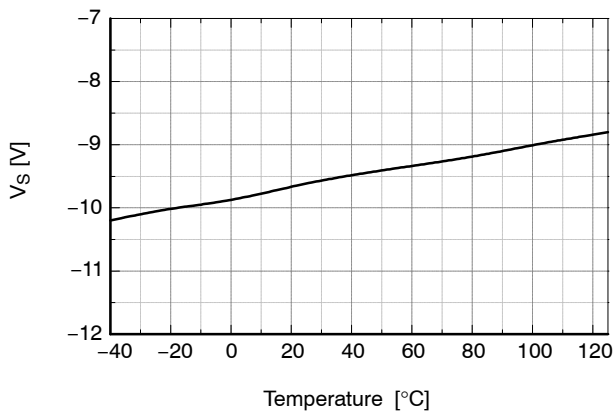

Figure 26. Allowable Negative V<sub>S</sub> vs. Temperature

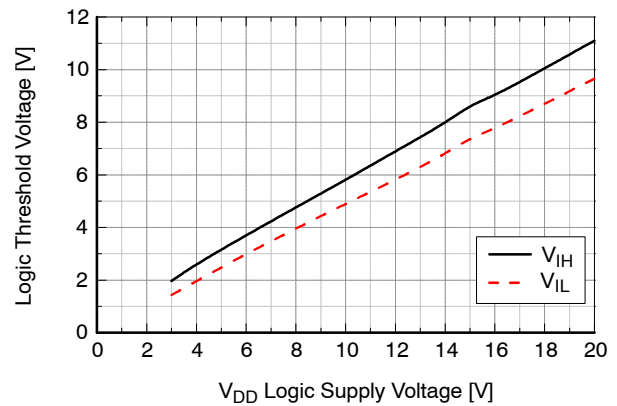
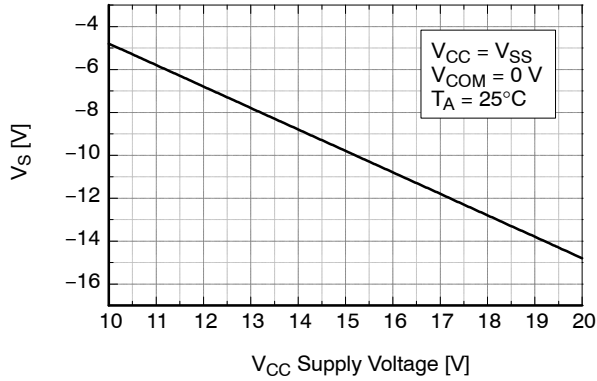

Figure 27. Input Logic (HIN&LIN) Threshold vs. V<sub>DD</sub> Supply Voltage

# FAN73912A

## TYPICAL CHARACTERISTICS (continued)



**Figure 28. Allowable Negative  $V_S$  Voltage for HIN Signal Propagation to High Side vs.  $V_{CC}$  Supply Voltage**

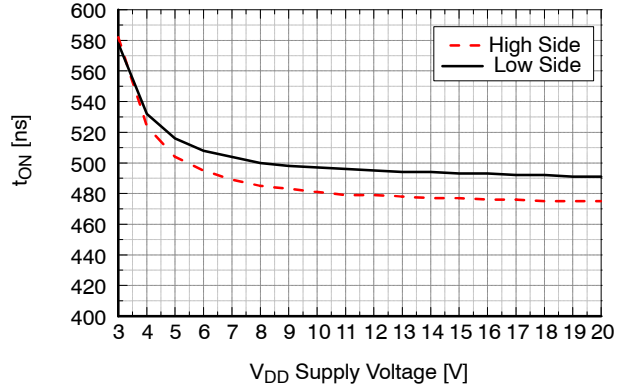

**Figure 29. Turn-On Propagation Delay vs.  $V_{DD}$  Supply Voltage**

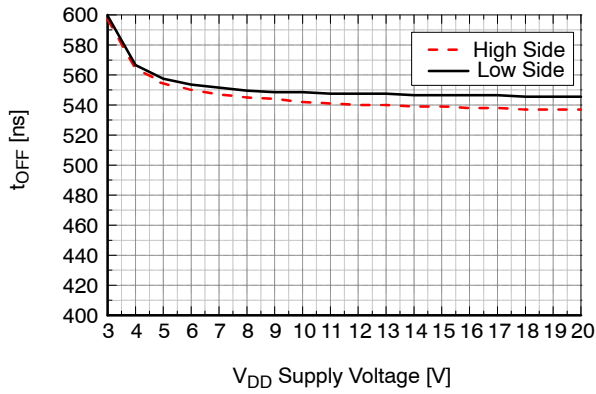

**Figure 30. Turn-Off Propagation Delay vs.  $V_{DD}$  Supply Voltage**

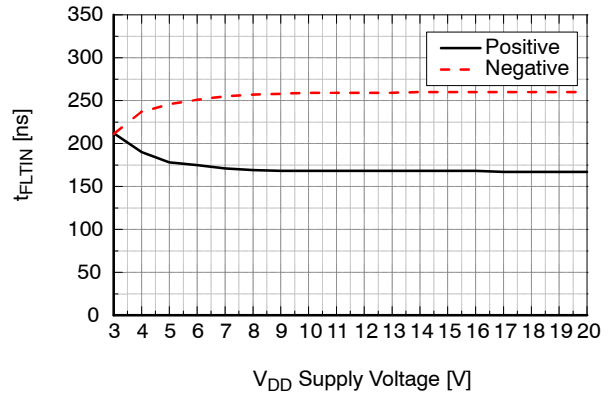

**Figure 31. Logic Input Filtering Time vs.  $V_{DD}$  Supply Voltage**

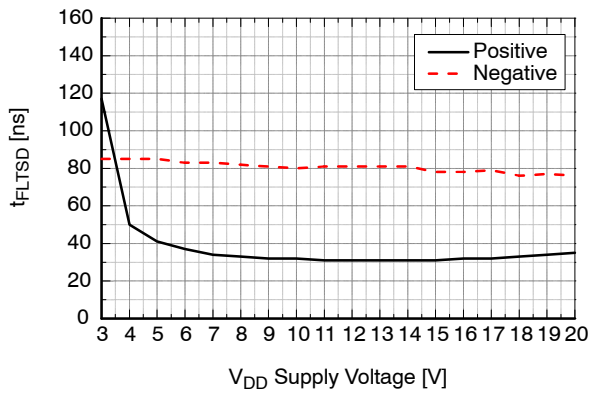

**Figure 32. Shutdown Input Filtering Time vs.  $V_{DD}$  Supply Voltage**

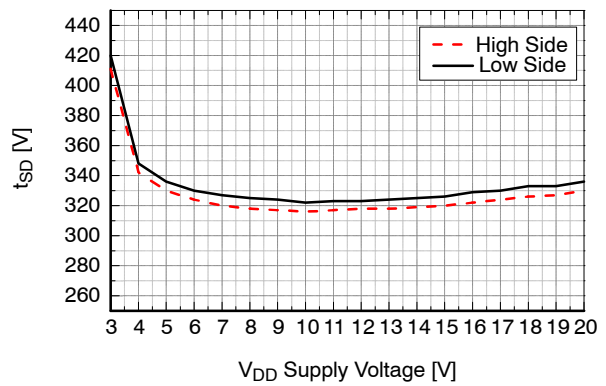

**Figure 33. Shutdown Propagation Delay vs.  $V_{DD}$  Supply Voltage**

# FAN73912A

## TYPICAL CHARACTERISTICS (continued)

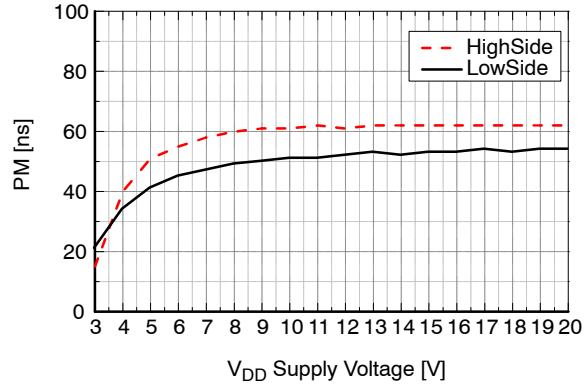

Figure 34. Output Pulse-Width Matching vs. V<sub>DD</sub> Supply Voltage

## SWITCHING TIME DEFINITIONS

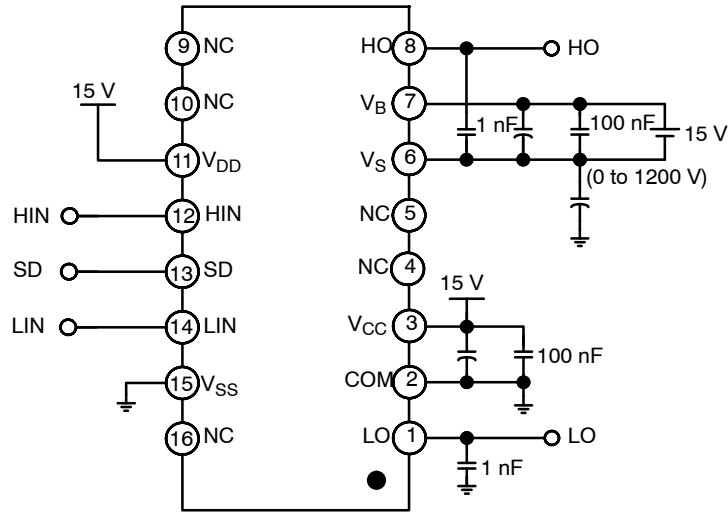

Figure 35. Switching Time Test Circuit

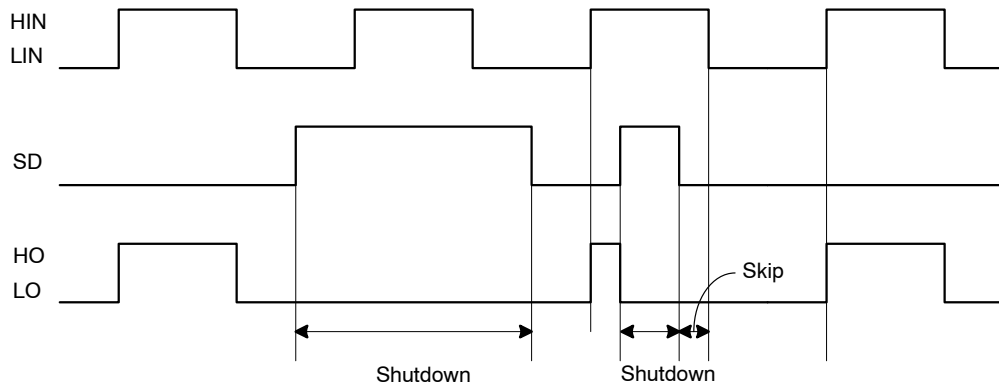

Figure 36. Input/Output Timing Diagram

# FAN73912A

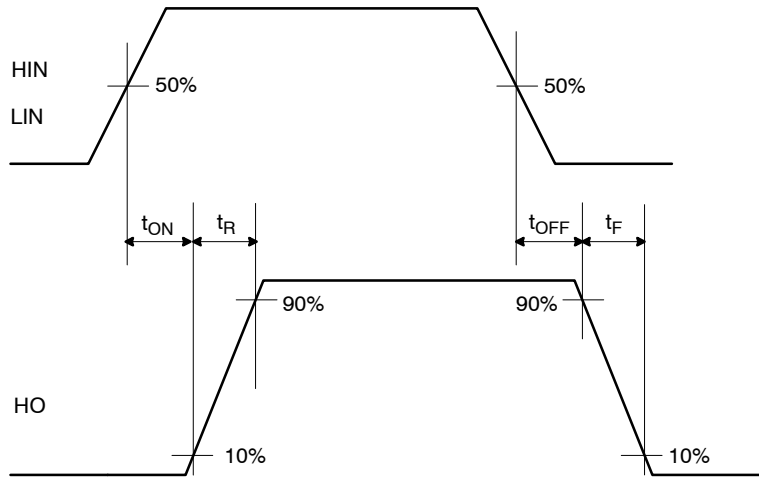

Figure 37. Switching Time Definition

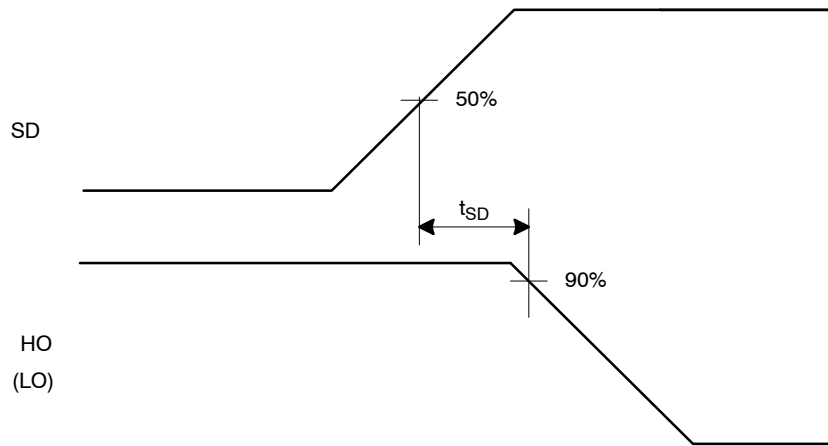

Figure 38. Shutdown Waveform Definition

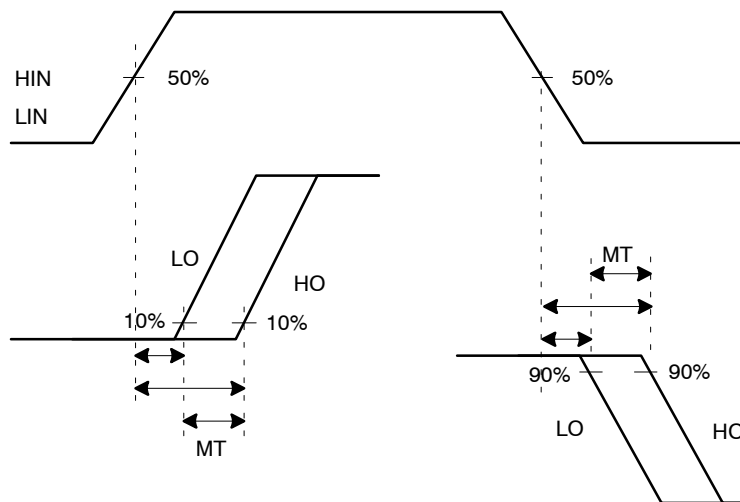

Figure 39. Delay Matching Waveform Definitions

APPLICATIONS INFORMATION

**Shutdown Input**

When the SD pin is in LOW state, the gate driver operates normally. When a condition occurs that should shut down the gate driver, the SD pin should be HIGH. The Shutdown circuitry has an input filter; the minimum input duration is specified by  $t_{FLTIN}$  (typically 250 ns).

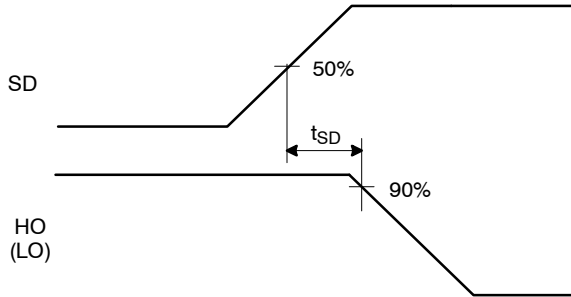

Figure 40. Output Shutdown Timing Waveform

**Noise Filter**

*Input Noise Filter*

Figure 41 shows the input noise filter method, which has symmetry duration between the input signal ( $t_{INPUT}$ ) and the output signal ( $t_{OUTPUT}$ ) and helps to reject noise spikes and short pulses. This input filter is applied to the HIN, LIN, and EN inputs. The upper pair of waveforms (Example A) shows an input signal duration ( $t_{INPUT}$ ) much longer than input filter time ( $t_{FLTIN}$ ); it is approximately the same duration between the input signal time ( $t_{INPUT}$ ) and the output signal time ( $t_{OUTPUT}$ ). The lower pair of waveforms (Example B) shows an input signal time ( $t_{INPUT}$ ) slightly longer than input filter time ( $t_{FLTIN}$ ); it is approximately the same duration between input signal time ( $t_{INPUT}$ ) and the output signal time ( $t_{OUTPUT}$ ).

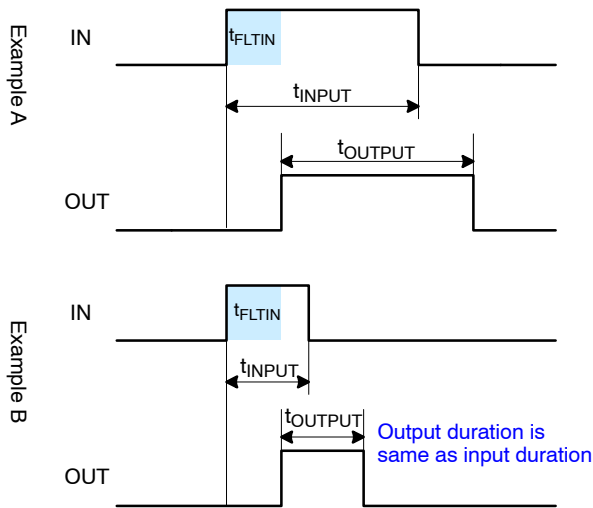

Figure 41. Input Noise Filter Definition

**Short-Pulsed Input Noise Rejection Method**

The input filter circuitry provides protection against short-pulsed input signals (HIN, LIN, and SD) on the input signal lines by applied noise signal.

If the input signal duration is less than input filter time ( $t_{FLTIN}$ ), the output does not change states.

Example A and B of the Figure 42 show the input and output waveforms with short-pulsed noise spikes with a duration less than input filter time; the output does not change states.

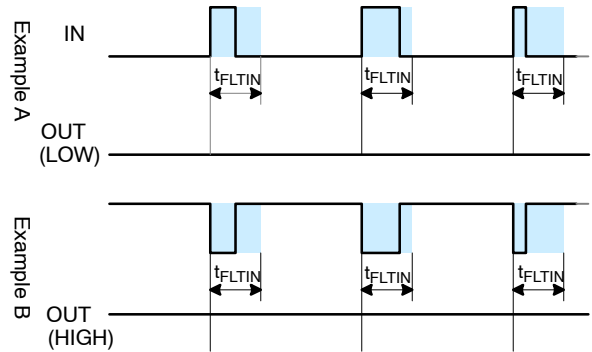

Figure 42. Noise Rejecting Input Filter Definition

**Negative VS Transient**

The bootstrap circuit has the advantage of being simple and low cost, but has some limitations. The biggest difficulty with this circuit is the negative voltage present at the emitter of the high-side switching device when high-side switch is turned-off in half-bridge application. If the high-side switch, Q1, turns-off while the load current is flowing to an inductive load, a current commutation occurs from high-side switch, Q1, to the diode, D2, in parallel with the low-side switch of the same inverter leg. Then the negative voltage present at the emitter of the high-side switching device, just before the freewheeling diode, D2, starts clamping, causes load current to suddenly flow to the low-side freewheeling diode, D2, as shown in Figure 43.

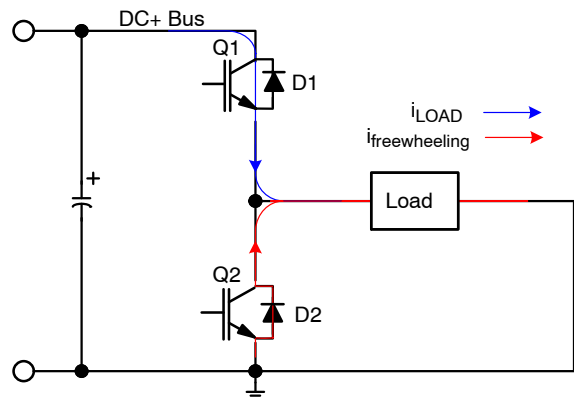

Figure 43. Half-Bridge Application Circuits

This negative voltage can be trouble for the gate driver's output stage, there is the possibility to develop an over-voltage condition of the bootstrap capacitor, input signal missing and latch-up problems because it directly affects the source VS pin of the gate driver, shown in Figure 44. This undershoot voltage is called "negative VS transient".

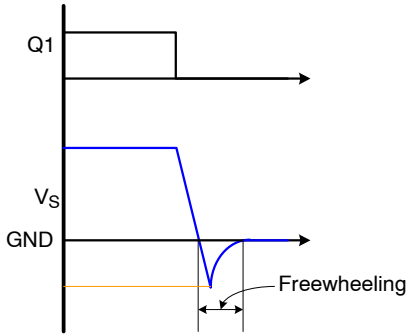

Figure 44. VS Waveforms During Q1 Turn-Off

Figure 45 and Figure 46 show the commutation of the load current between high-side switch, Q1, and low-side freewheeling diode, D3, in same inverter leg. The parasitic inductances in the inverter circuit from the die wire bonding to the PCB tracks are jumped together in LC and LE for each IGBT. When the high-side switch, Q1, and low-side switch, Q4, are turned on, the VS1 node is below DC+ voltage by the voltage drops associated with the power switch and the parasitic inductances of the circuit due to load current is flows from Q1 and Q4, as shown in Figure 45. When the high-side switch, Q1, is turned off and Q4, remained turned on, the load current to flows the low-side freewheeling diode, D3, due to the inductive load connected to VS1 as shown in Figure 46. Q1 Turn-Off and D3 Conducting. The current flows from ground (which is connected to the COM pin of the gate driver) to the load and the negative voltage present at the emitter of the high-side switching device. In this case, the COM pin of the gate driver is at a higher potential than the VS pin due to the voltage drops associated with freewheeling diode, D3, and parasitic elements, LC3 and LE3.

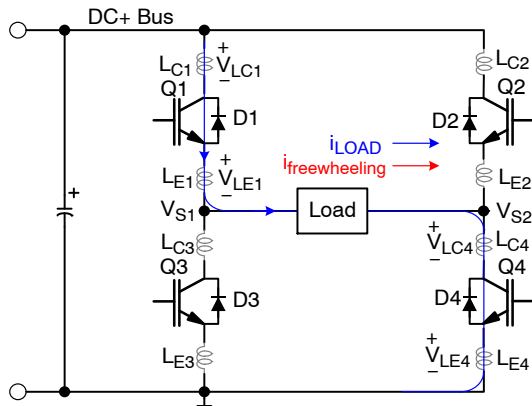

Figure 45. Q1 and Q4 Turn-On

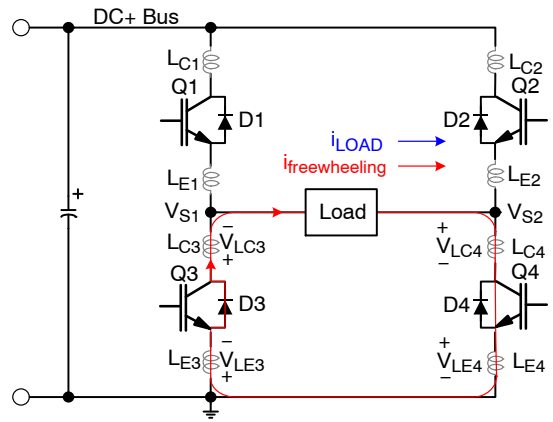

Figure 46. Q1 Turn-Off and D3 Conducting

The FAN73912A has a typical negative VS transient characteristics, as shown in Figure 47.

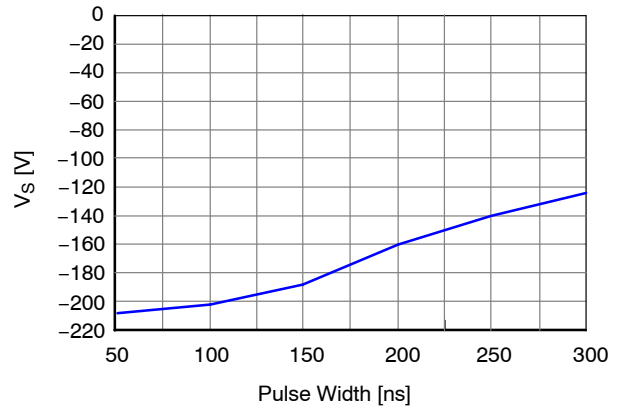

Figure 47. Negative VS Transient Characteristic

Even though the FAN73912A has been shown able to handle these negative VS transient conditions, it is strongly recommended that the circuit designer limit the negative VS transient as much as possible by careful PCB layout to minimize the value of parasitic elements and component use. The amplitude of negative VS voltage is proportional to the parasitic inductances and the turn-off speed, di/dt, of the switching device.

**General Guidelines**

*Printed Circuit Board Layout*

The layout recommended for minimized parasitic elements is as follows:

- Direct tracks between switches with no loops or deviation.
- Avoid interconnect links. These can add significant inductance.
- Reduce the effect of lead-inductance by lowering package height above the PCB.
- Consider co-locating both power switches to reduce track length.

## FAN73912A

- To minimize noise coupling, the ground plane should not be placed under or near the high-voltage floating side.
- To reduce the EM coupling and improve the power switch turn-on/off performance, the gate drive loops must be reduced as much as possible.

### *Placement of Components*

The recommended placement and selection of component as follows:

- Place a bypass capacitor between the  $V_{CC}$  and  $V_{SS}$  pins. A ceramic 1  $\mu$ F capacitor is suitable for most applications. This component should be placed as close as possible to the pins to reduce parasitic elements.
  - The bypass capacitor from  $V_{CC}$  to  $V_{SS}$  supports both the low-side driver and bootstrap capacitor recharge. A value at least ten times higher than the bootstrap capacitor is recommended.
  - The bootstrap resistor,  $R_{BOOT}$ , must be considered in sizing the bootstrap resistance and the current developed during initial bootstrap charge. If the resistor is needed in series with the bootstrap diode, verify that  $V_B$  does not fall below COM (ground). Recommended use is typically 5 ~ 10  $\Omega$  that increase the  $V_{BS}$  time constant. If the voltage drop of bootstrap resistor and diode is too high or the circuit topology does not allow a sufficient charging time, a fast recovery or ultra-fast recovery diode can be used.
- The bootstrap capacitor,  $C_{BOOT}$ , uses a low-ESR capacitor, such as ceramic capacitor. It is strongly recommended that the placement of components is as follows:
    - Place components tied to the floating voltage pins ( $V_B$  and  $V_S$ ) near the respective high-voltage portions of the device and the FAN73912A. Not Connected (NC) pins in this package maximize the distance between the high-voltage and low-voltage pins (see Figure 3).
    - Place and route for bypass capacitors and gate resistors as close as possible to gate drive IC.
    - Locate the bootstrap diode,  $D_{BOOT}$ , as close as possible to bootstrap capacitor,  $C_{BOOT}$ .
    - The bootstrap diode must use a lower forward voltage drop and minimal switching time as soon as possible for fast recovery or ultra-fast diode.





**SOIC-16, 300 mils**  
**CASE 751BH-01**  
**ISSUE A**

DATE 18 MAR 2009

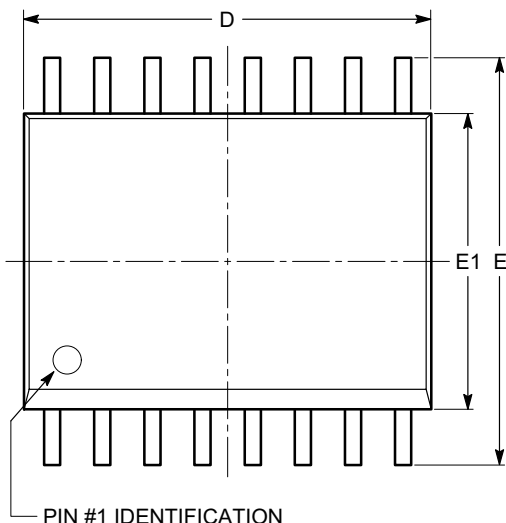

**TOP VIEW**

SYMBOL	MIN	NOM	MAX
A	2.36	2.49	2.64
A1	0.10		0.30
b	0.33	0.41	0.51
c	0.18	0.23	0.28
D	10.08	10.31	10.49
E	10.01	10.31	10.64
E1	7.39	7.49	7.59
e	1.27 BSC		
h	0.25		0.75
L	0.38	0.81	1.27
$\theta$	0°		8°

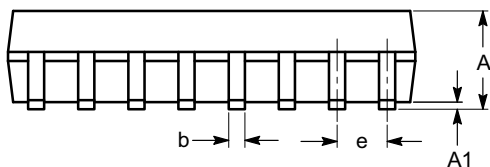

**SIDE VIEW**

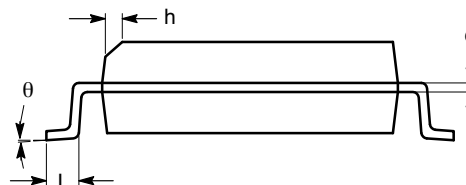

**END VIEW**

**Notes:**

- (1) All dimensions are in millimeters. Angles in degrees.
- (2) Complies with JEDEC MS-013.

<b>DOCUMENT NUMBER:</b>	<b>98AON34279E</b>	Electronic versions are uncontrolled except when accessed directly from the Document Repository. Printed versions are uncontrolled except when stamped "CONTROLLED COPY" in red.
<b>DESCRIPTION:</b>	<b>SOIC-16, 300 MILS</b>	<b>PAGE 1 OF 1</b>

ON Semiconductor and are trademarks of Semiconductor Components Industries, LLC dba ON Semiconductor or its subsidiaries in the United States and/or other countries. ON Semiconductor reserves the right to make changes without further notice to any products herein. ON Semiconductor makes no warranty, representation or guarantee regarding the suitability of its products for any particular purpose, nor does ON Semiconductor assume any liability arising out of the application or use of any product or circuit, and specifically disclaims any and all liability, including without limitation special, consequential or incidental damages. ON Semiconductor does not convey any license under its patent rights nor the rights of others.

**onsemi**, **Onsemi**, and other names, marks, and brands are registered and/or common law trademarks of Semiconductor Components Industries, LLC dba "**onsemi**" or its affiliates and/or subsidiaries in the United States and/or other countries. **onsemi** owns the rights to a number of patents, trademarks, copyrights, trade secrets, and other intellectual property. A listing of **onsemi**'s product/patent coverage may be accessed at [www.onsemi.com/site/pdf/Patent-Marking.pdf](http://www.onsemi.com/site/pdf/Patent-Marking.pdf). **onsemi** reserves the right to make changes at any time to any products or information herein, without notice. The information herein is provided "as-is" and **onsemi** makes no warranty, representation or guarantee regarding the accuracy of the information, product features, availability, functionality, or suitability of its products for any particular purpose, nor does **onsemi** assume any liability arising out of the application or use of any product or circuit, and specifically disclaims any and all liability, including without limitation special, consequential or incidental damages. Buyer is responsible for its products and applications using **onsemi** products, including compliance with all laws, regulations and safety requirements or standards, regardless of any support or applications information provided by **onsemi**. "Typical" parameters which may be provided in **onsemi** data sheets and/or specifications can and do vary in different applications and actual performance may vary over time. All operating parameters, including "Typicals" must be validated for each customer application by customer's technical experts. **onsemi** does not convey any license under any of its intellectual property rights nor the rights of others. **onsemi** products are not designed, intended, or authorized for use as a critical component in life support systems or any FDA Class 3 medical devices or medical devices with a same or similar classification in a foreign jurisdiction or any devices intended for implantation in the human body. Should Buyer purchase or use **onsemi** products for any such unintended or unauthorized application, Buyer shall indemnify and hold **onsemi** and its officers, employees, subsidiaries, affiliates, and distributors harmless against all claims, costs, damages, and expenses, and reasonable attorney fees arising out of, directly or indirectly, any claim of personal injury or death associated with such unintended or unauthorized use, even if such claim alleges that **onsemi** was negligent regarding the design or manufacture of the part. **onsemi** is an Equal Opportunity/Affirmative Action Employer. This literature is subject to all applicable copyright laws and is not for resale in any manner.

---

## ADDITIONAL INFORMATION

### TECHNICAL PUBLICATIONS:

Technical Library: [www.onsemi.com/design/resources/technical-documentation](http://www.onsemi.com/design/resources/technical-documentation)  
onsemi Website: [www.onsemi.com](http://www.onsemi.com)

### ONLINE SUPPORT: [www.onsemi.com/support](http://www.onsemi.com/support)

For additional information, please contact your local Sales Representative at [www.onsemi.com/support/sales](http://www.onsemi.com/support/sales)

