



System Solution Guide - Preview

48V-12V DC-DC Converter



onsemi.com



Table of Contents

Get Latest
Version

Overview	03
Market Information & Trend	
48V Systems in Electric Vehicles – Market Trends One Pager	04
System Description	
48V DC-DC Converter: Technology and Architecture Introduction	05
DC-DC Converter and 48V System in MHEV	06
Solution Overview	
48V-12V DC-DC Converter - Block Diagram	08
Power Stage of Multiphase Bidirectional DC-DC Converter	09
Automotive Power Modules (APM) in 48V DC-DC Converter	10
Discrete MOSFET Approach to Building a 48V DC-DC Converter	11
MOSFET Technology – From Successful T8 and T6 to the Latest T10 Generation	12
Gate Drivers for 48V Systems and Applications	13
10BASE-T1S Ethernet Transceiver and ESD Protection	15
Component Redundancy in 48V Systems	16
APM17 Back-to-Back MOSFET Module as Battery and Load Switch	17
Improving Protection and Robustness of Automotive Circuits	18
Recommended Products	19
Complementary Products	21
Development Tools and Resources	23



onsemi
System Solution Guide
48V-12V DC-DC
Converter

Register now to unlock all System Solution Guides



1



2



3



4



5



6



7



8

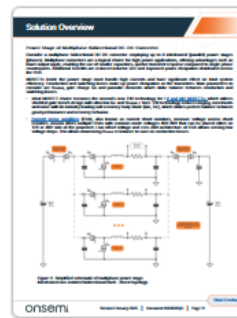

9



10



11

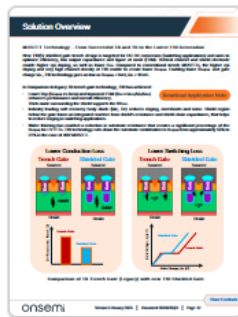

12



13

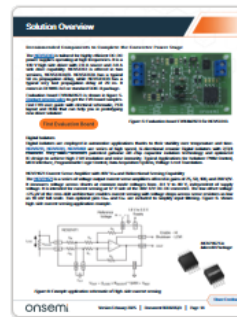

14

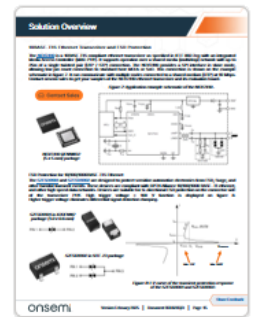

15



16



17

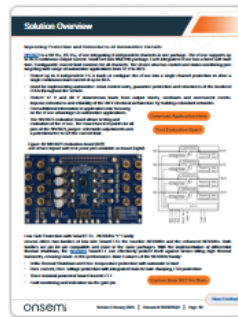

18

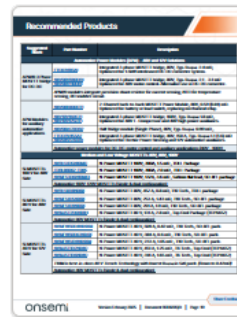

19

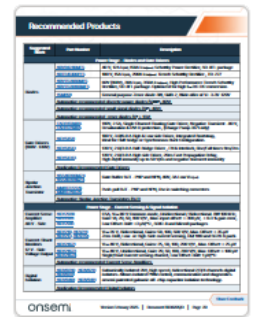

20

Block Diagram

Get Latest Version

48V-12V DC-DC Converter - Block Diagram

The prevalent power stage topology in this application is the **non-isolated synchronous step-down converter**. Synchronous switches facilitate bidirectional current flow to allow boost mode. When observed from the 48 V side, the configuration functions as a synchronous step-down converter, while from the 12 V side, it transforms into a synchronous step-up converter.

Power stage can be designed with discrete MOSFETs or integrated automotive power modules (APM). **onsemi** offers variety of components to scale the design up or down in terms of power level and optimize the sum of conduction and switching losses. Choosing key and complementary components such as gate drivers, digital isolators and auxiliary power supplies completes the design. Find **onsemi's** components offer in the **Recommended & Complementary Products** sections of the full System Solution Guide.

LC filter can be placed on the 48 V side to mitigate output voltage ripple in boost mode. Spreading power over more interleaved phases also reduces output voltage ripple. The bidirectional capability significantly influences the choice of passive components. To allow bidirectional operation, capacitors inside the power stage dynamically shift their function. Passive components choice becomes a tradeoff between reducing output voltage ripple, overshoots, and system cost.

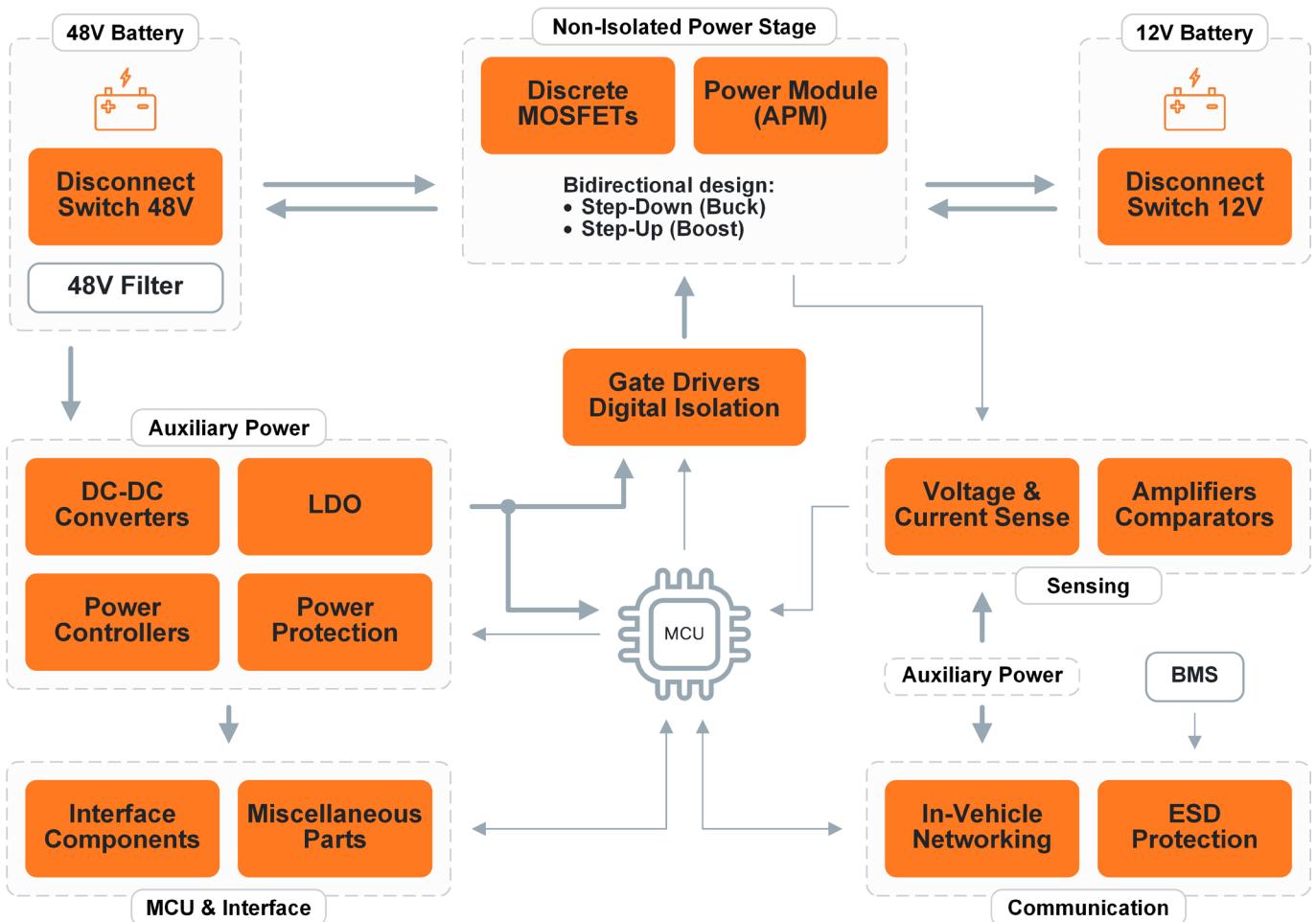

Use our Interactive Block Diagrams Tool



Open IBD Tool

Automotive Power Modules (APM) in 48V DC-DC Converter

onsemi offers multiple series of integrated automotive power modules (APM) in a variety of packages that are designed for power applications in 48V systems, MHEV and low voltage traction systems. APMs elevate highly integrated and compact design with low stray inductance and better electromagnetic interference (EMI). The module's efficient current handling simplifies the high current path on the PCB. APMs integrate a shunt resistor, NTC and snubber circuit.

Find Products

Table 1: APM modules offering for multiple 48V applications

APM19	APM19, APM21	APM17	APM12 , APM17
2x APM19 for 6-phase 3 kW interleaved DC-DC converter	48V Power Auxiliaries (E-Compressor, E-Turbo and more)	2-Channel back-to-back MOSFET (Disconnect switch)	3x APM17 for 6 phase Inverter solution (15- 25 kW)

The APM19 module [FTC03V85A1](#) is 80 V low $R_{DS(ON)}$ module, featuring a 3-phase MOSFET bridge optimized for building a 1.5 kW 48V-12V interleaved DC-DC converter. The APM19 can be used in the synchronous step-down converter topology, where one module handles 3 phases in the converter (2 MOSFET switches per phase) that account for up to 1.5 kW. Two modules can scale up this design to a 3 kW converter (6 phases). Synchronous switches in each phase allow bidirectional current flow in the boost mode. The multiphase interleaved approach for the DC-DC converter reduces output ripple current and thus allows designers to use smaller capacitors with less capacitance and achieve faster transient response. The [NXV08V110DB1](#) is an alternative module for building the same DC-DC converter topology, but it is better optimized for motor control applications.

- MOSFET dies integrated in the APM19 are selected to balance the sum of conduction and switching losses that result from MOSFETs $R_{DS(ON)}$, gate charge Q_G and other parasitics.
- An RC snubber circuit is already integrated in APM19 module that is ready for damping the parasitic inductances and capacitances on the switch node during switching transitions.
- Integrated precision shunt resistor for current sensing is optimized for low parasitic inductance and good stability across the entire temperature range.

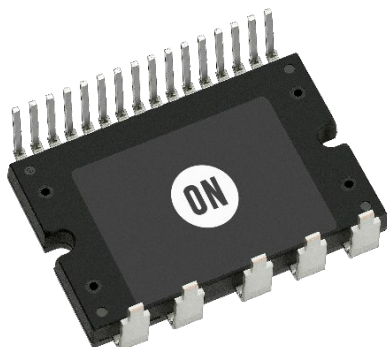

44 x 29 x 5 mm

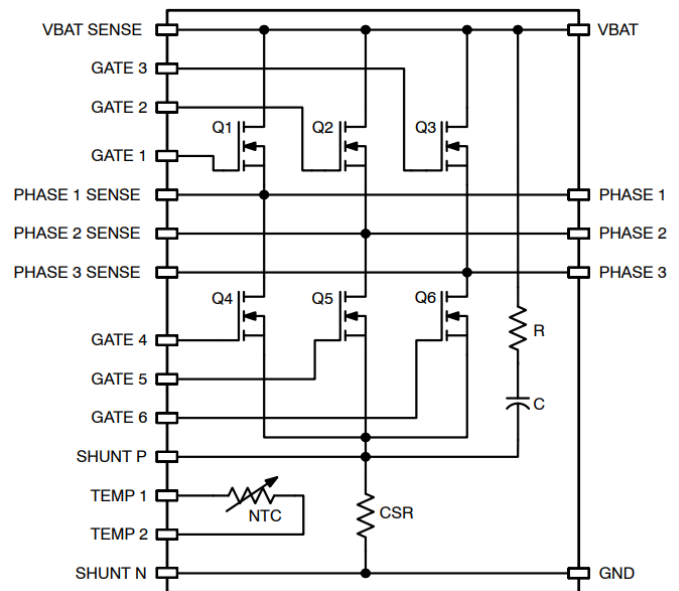

Figure: APM19 3-Phase Module internal layout: MOSFET bridge, NTC, current shunt resistor and RC snubber.

Gate Drivers for 48V Systems and Applications

The [FAD3151MXA](#) and [FAD3171MXA](#) are **single channel floating automotive gate drivers with 110 V, 2.5 A source/sink capability**, suitable for driving high-speed power MOSFETs up to 110 V. Designed in a SOI substrate technology, the drivers are ideal for applications that require noise immunity against severe **negative transients and ground offset down to -80 V**. The drivers are equipped with bidirectional fault reporting pin that can generate a fault output during DESAT and under-voltage lockout (UVLO) conditions. The bidirectional nature of the fault-reporting pin allows the driver to respond to external fault commands, thereby facilitating fault communication across the system

Besides DC-DC Converter, they can be used in multiple 48 V applications like Battery Switches, Auxiliaries (HVAC, e-Turbo), PTC heater, Starter-Generator. Driver features include:

- Drain-Source desaturation detection with soft shutdown. Desaturation protection has adjustable threshold and blanking time. UVLO protection, Bi-directional fault reporting pin.
- Integrated charge pump to support 100% duty cycle operation (FAD3171MXA only)

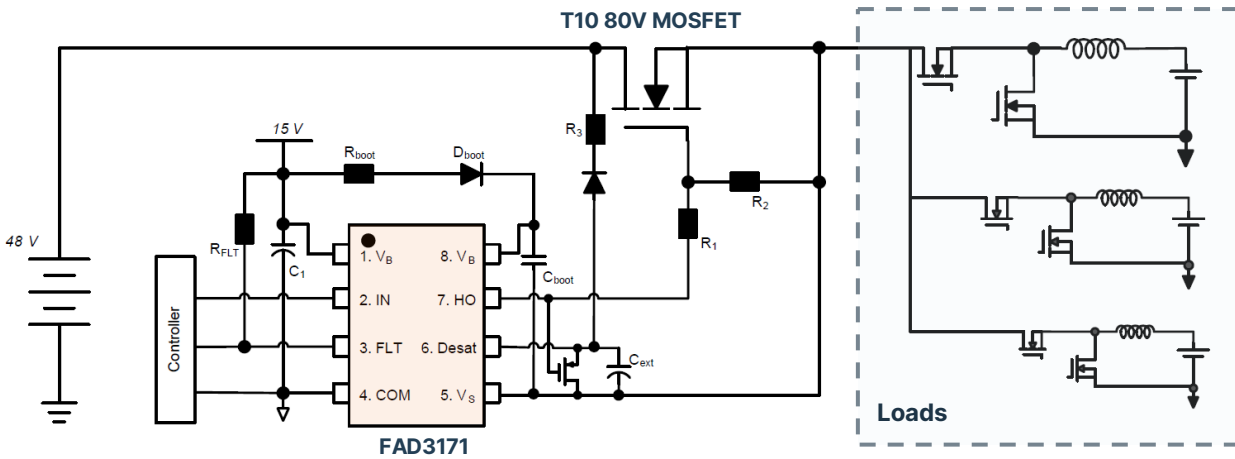

Figure: Application Example Schematic: FAD3171 drives a T10 MOSFET as a 48V battery main switch

Find Products

Download Application Note

NCV21671 Current Sense Amplifier with 40V V_{CM} and Bidirectional Sensing Capability

The [NCV21671](#) is a series of voltage output current sense amplifiers offered in gains of 25, 50, 100, and 200 V/V. It measures voltage across shunts at common mode voltages from -0.1 V to 40 V, independent of supply voltage. It is intended for current sensing at 12 V side of the 48V-12V DC-DC converter.

The low offset voltage $\pm 25 \mu\text{V}$ of the zero-drift architecture enables current sensing with voltage drops across sense resistors as low as 10 mV full-scale. Two optional pins C_{IN+} and C_{IN-} are included to simplify input filtering. Example figure shows high-side current sensing application example.

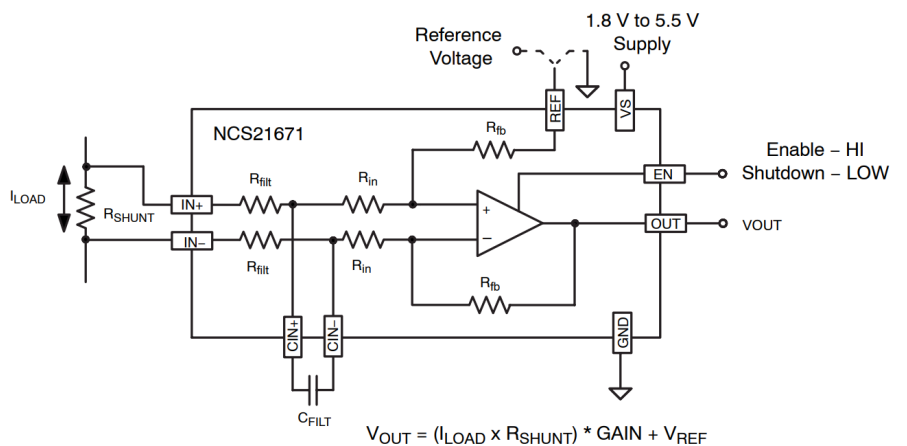
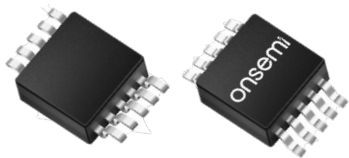

Figure: Example application schematic of High-side current sensing

48V-12V DC-DC Converter

Get Latest
Version

onsemi™

Intelligent Technology. Better Future.

Register now to unlock all System Solution Guides and get additional exclusive benefits!

- Join the conversation on community forum.
- Utilize Elite Power Simulator & other developer tools.
- Watch exclusive webinars and seminars.

Open full System Solution Guide



onsemi, the onsemi logo, and other names, marks, and brands are registered and/or common law trademarks of Semiconductor Components Industries, LLC dba "onsemi" or its affiliates and/or subsidiaries in the United States and/or other countries. onsemi owns the rights to a number of patents, trademarks, copyrights, trade secrets, and other intellectual property. A listing of onsemi's product/patent coverage may be accessed at www.onsemi.com/site/pdf/Patent-Marking.pdf. onsemi reserves the right to make changes at any time to any products or information herein, without notice. The information herein is provided "as-is" and onsemi makes no warranty, representation or guarantee regarding the accuracy of the information, product features, availability, functionality, or suitability of its products for any particular purpose, nor does onsemi assume any liability arising out of the application or use of any product or circuit, and specifically disclaims any and all liability, including without limitation special, consequential or incidental damages. Buyer is responsible for its products and applications using onsemi products, including compliance with all laws, regulations and safety requirements or standards, regardless of any support or applications information provided by onsemi. "Typical" parameters which may be provided in onsemi data sheets and/or specifications can and do vary in different applications and actual performance may vary over time. All operating parameters, including "Typicals" must be validated for each customer application by customer's technical experts. onsemi does not convey any license under any of its intellectual property rights nor the rights of others. onsemi products are not designed, intended, or authorized for use as a critical component in life support systems or any FDA Class 3 medical devices or medical devices with a same or similar classification in a foreign jurisdiction or any devices intended for implantation in the human body. Should Buyer purchase or use onsemi products for any such unintended or unauthorized application, Buyer shall indemnify and hold onsemi and its officers, employees, subsidiaries, affiliates, and distributors harmless against all claims, costs, damages, and expenses, and reasonable attorney fees arising out of, directly or indirectly, any claim of personal injury or death associated with such unintended or unauthorized use, even if such claim alleges that onsemi was negligent regarding the design or manufacture of the part. onsemi is an Equal Opportunity/Affirmative Action Employer. This literature is subject to all applicable copyright laws and is not for resale in any manner.