

**WLCSP10 1.84x1.96x0.13
CASE 567VW
ISSUE O**

DATE 28 FEB 2018

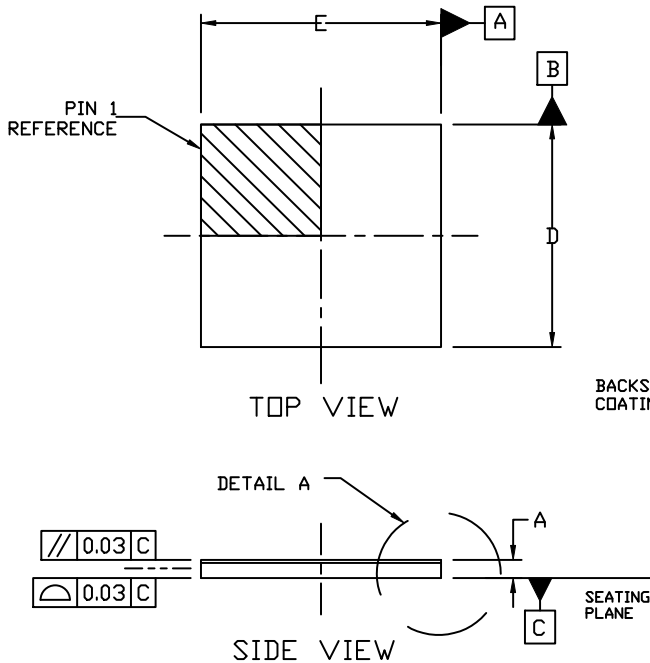

NOTES:

- DIMENSIONING AND TOLERANCING PER ASME Y14.5M, 1994.
- CONTROLLING DIMENSION: MILLIMETERS

| DIM | MILLIMETERS | | |
|-----|-------------|-------|------|
| | MIN. | NOM. | MAX. |
| A | 0.10 | 0.125 | 0.15 |
| A3 | 0.025 REF | | |
| b | 0.22 | 0.25 | 0.28 |
| b1 | 0.22 | 0.25 | 0.28 |
| b2 | 0.50 | 0.53 | 0.56 |
| D | 1.81 | 1.84 | 1.87 |
| E | 1.93 | 1.96 | 1.99 |
| e | 0.90 BSC | | |
| e1 | 0.50 BSC | | |
| e2 | 0.40 BSC | | |
| e3 | 0.64 BSC | | |

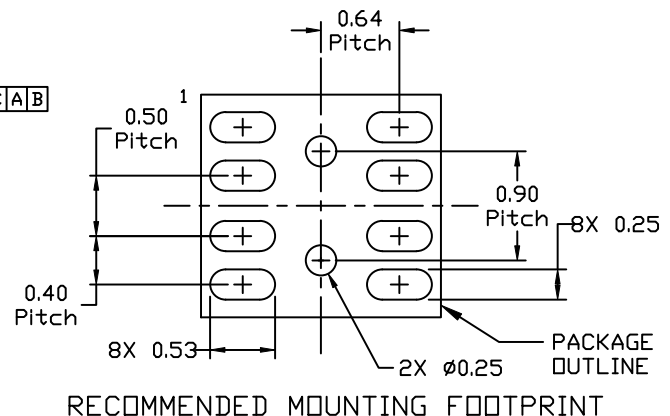
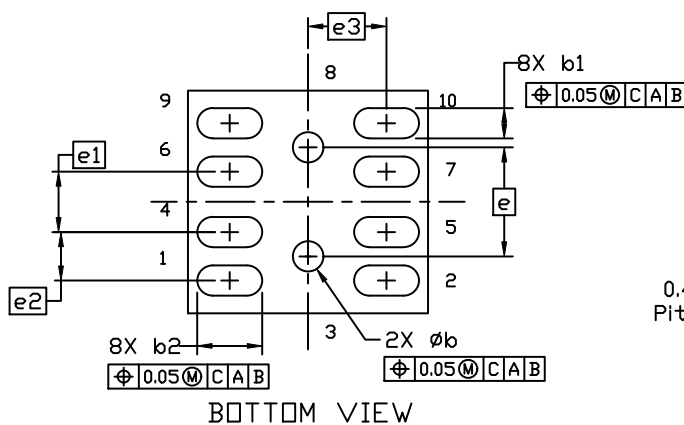

**GENERIC
MARKING DIAGRAM***



- A = Assembly Location
- Y = Year
- W = Work Week
- ZZ = Assembly Lot

*This information is generic. Please refer to device data sheet for actual part marking. Pb-Free indicator, "G" or microdot "▪", may or may not be present. Some products may not follow the Generic Marking.

| | | |
|-------------------------|-------------------------------|--|
| DOCUMENT NUMBER: | 98AON83924G | Electronic versions are uncontrolled except when accessed directly from the Document Repository. Printed versions are uncontrolled except when stamped "CONTROLLED COPY" in red. |
| DESCRIPTION: | WLCSP10 1.84x1.96x0.13 | PAGE 1 OF 1 |

onsemi and ONSEMI are trademarks of Semiconductor Components Industries, LLC dba onsemi or its subsidiaries in the United States and/or other countries. onsemi reserves the right to make changes without further notice to any products herein. onsemi makes no warranty, representation or guarantee regarding the suitability of its products for any particular purpose, nor does onsemi assume any liability arising out of the application or use of any product or circuit, and specifically disclaims any and all liability, including without limitation special, consequential or incidental damages. onsemi does not convey any license under its patent rights nor the rights of others.