



Test Procedure for the SECO-LVDCDC3064-SIC-GEVB Evaluation Board

Necessary equipment:

- Regulated DC source
- 4 x DC volt-meter
- 4 x DC amp-meter
- 3 channel electronic load

Test Procedure:

1. Connect the test setup as shown in the figure 1.
2. Set 15V on DC source
3. During no load state measure 5.2V at P5V, -5.2V at N5V and 21.2V at P20V branch (tolerance for each of branch is $\pm 2\%$)
4. During full load state (50mA at each of branch) measure 5V at P5V, -5V at N5V and 20.3V at P20V (tolerance for each of branch is $\pm 2\%$)

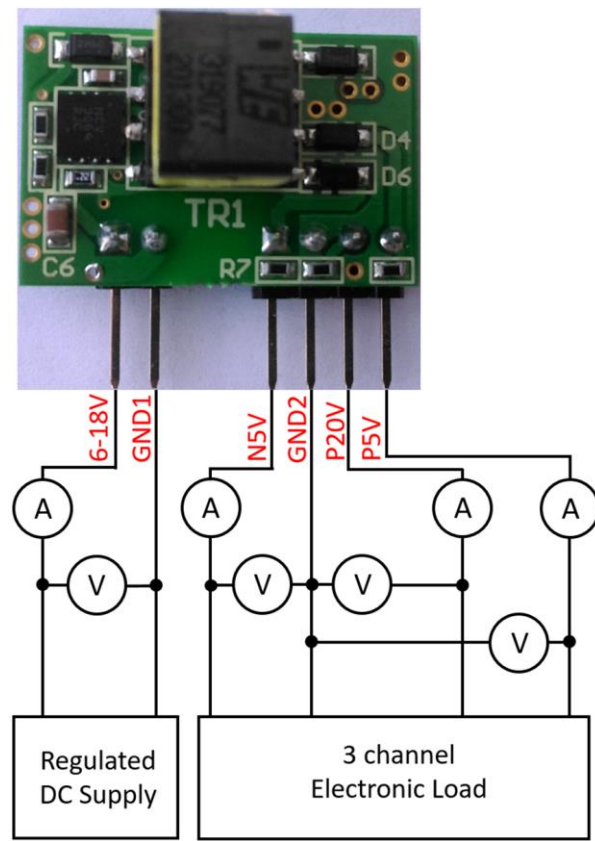

Figure 1. Test Setup