

NB7V33MMNGEVB

Assembly and Test Manual

For more detailed information on the QFN16 evaluation board, see the QFN16EVB application note.

Table 1. Configuration for Device: NB7V33M

	J1	J2	J3	J4	J5	J6	J7	J8	J9	J10	J11	J12	J13	J14	J15	J16
Device Pin #	1	2	3	4	5	6	7	8	9	10	11	12	13	14	15	16
SMA Connector	Yes	Yes	Yes	Yes	No	No	No	No	No	Yes	Yes	No	No	No	Yes	No
Wire	No	No	No	No	No	GND	GND	GND	VCC	No	No	VCC	VCC	VCC	No	VCC

Note: DUTGND / VEE = Exposed Pad and must be tied to DUTGND / VEE

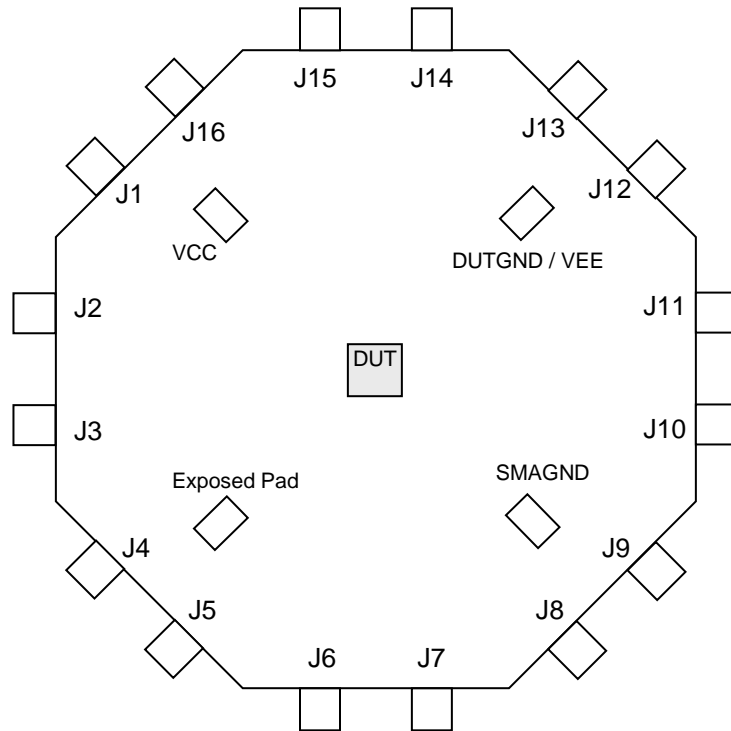

Top View

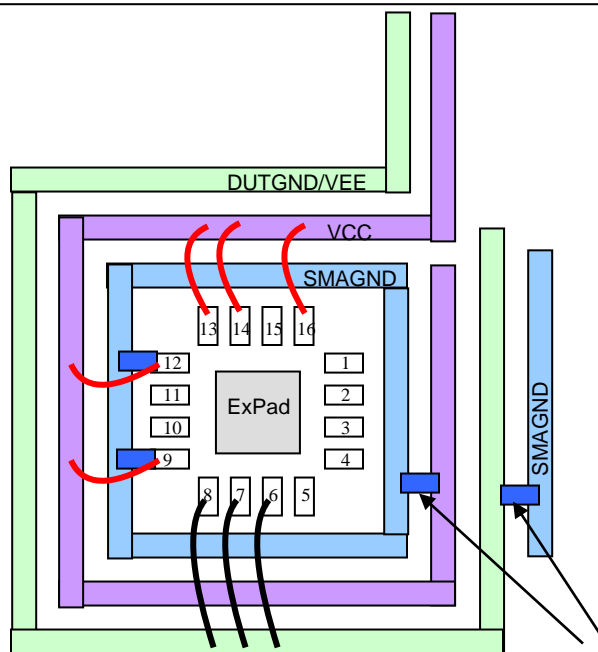

Bottom View

Polarity of 22uF:

+ C4 - + C2 -

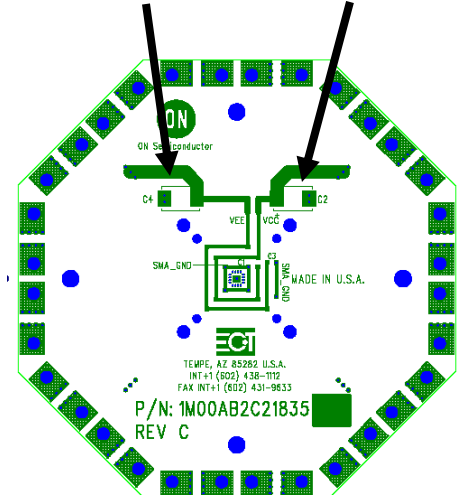

Install 0.1uF Decoupling Capacitors here and at package pins

Table 2. Bill of Materials

Components	Manufacturer	Description	Part Number	QTY	Web Site
SMA Connector	Rosenberger	SMA Connector, Side Launch, Gold Plated	32K243-40ME3	7	http://www.rosenberger.de http://www.rosenbergerna.com
Surface Mount Test Points	Keystone*	SMT Miniature Test Point	5015	4	http://www.keyelco.com
Chip Capacitor	AVC Corporation*	0603 0.01 μ F \pm 10% 0603 0.1 μ F \pm 10%	06035C103KAT2A 0603C104KAT2A	na 2	http://www.avxcorp.com
Chip Resistor	Panasonic*	0402 50 Ω \pm 1% Precision Thick Film Chip Resistor	ERJ-2RKF49R9X	na	http://www.panasonic.com
Evaluation Board	ON Semiconductor	QFN-16 Evaluation Board	QFN16EVB	1	http://www.onsemi.com
Device Samples	ON Semiconductor	QFN 16 Package Device	NB7V33MMNG	1	http://www.onsemi.com

*Components are available through most distributors, i.e. www.newark.com, www.Digikey.com

NB7V33MMNGEVB Test

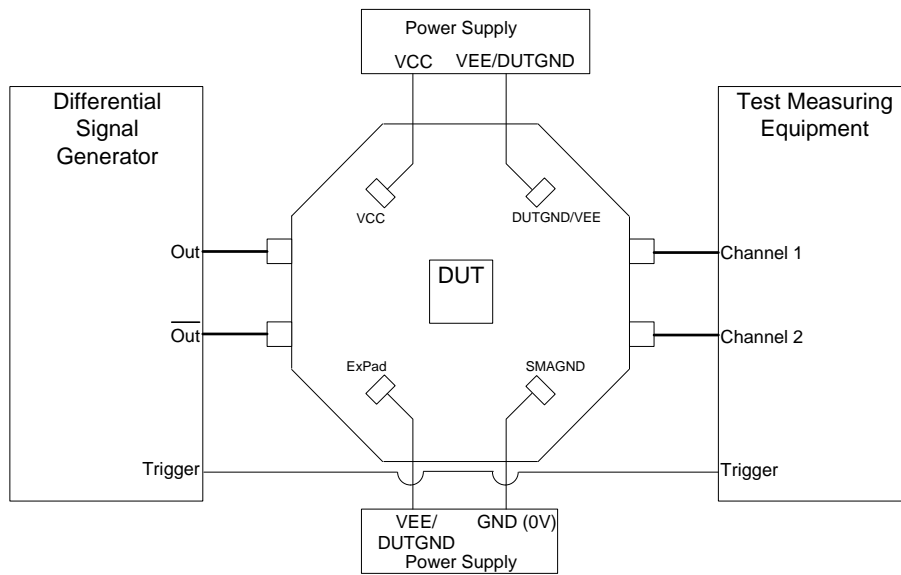

Basic Lab Setup (typical)

1. Connect the appropriate power supplies to VCC, VEE/DUTGND, SMAGND, and ExPad (See Table 2.).
 2. Connect a signal generator to the input SMA connectors. Setup input signal according to the device data sheet.
 3. Connect a test measurement device to the device's output SMA connectors.
- NOTE: The test measurement device must contain 50-Ω termination.

Table 3. Power Supply Levels

Outputs	Power Supply	VCC	VEE / DUTGND	SMAGND	ExPad (typ.)
CML	2.5V	0.0V	-2.5V	0.0V	VEE / DUTGND
CML	1.8V	0.0V	-1.8V	0.0V	VEE / DUTGND

Table 3. NB7xxxM, CML Outputs “Split” Power Supply Configuration

Device Pin Power Supply Connector	“Spilt” Power Supply
VCC	VCC = 0.0V
SMAGND	VTT = 0V
DUTGND	DUTGND = -2.5V or -1.8V

“Split” or Dual Power Supply Connections

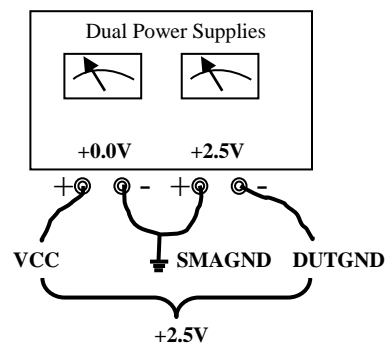

Offset / “Split” Power Supply Configuration