

# FAN53555 Evaluation Board User's Manual

## 5 A, 2.4 MHz, Digitally Programmable TinyBuck Regulator

### EVBUM2953/D

This user guide supports the evaluation kit for the FAN53555. It should be used in conjunction with the FAN53555 datasheet.

#### DESCRIPTION

The FAN53555 evaluation board is a compact circuit which includes onsemi's FAN53555 digitally

programmable buck regulator capable of delivering up to 5 A peak load at a 2.4 MHz fixed frequency. The regulator is offered in a 20-bump, 1.6 x 2 mm, WLCSP.

The evaluation board provides probe access points to all key circuit nodes so that electrical characteristics can be measured.

Table 1. FEATURES

Part Number	Output Voltage	VSEL	I <sup>2</sup> C Address	Temperature Range
FAN53555UC04X	I <sup>2</sup> C Controlled	VSEL0, VSEL1	7h'60	-40 °C to 85 °C

#### Features

- Input Voltage Range: 2.5 V to 5.5 V
- Output Voltage: Programmable from 0.603 V to 1.411 V in 12.826 mV Steps
- Programmable Slew Rate for Voltage Transitions
- I<sup>2</sup>C Compatible Interface up to 3.4 Mbps
- PFM Mode for High Efficiency in light load
- Quiescent Current in PFM Mode: 60 μA (Typical)
- Internal Soft-Start
- Input Under-Voltage Lockout (UVLO)
- Thermal Shutdown and Overload Protection
- 20-Bump Wafer-Level Chip Scale Package (WLCSP)

#### Quick Start Connection Guide

1. Connect input power supply between VIN and GND. See Figure 1a.
2. Connect external load between VOUT and GND. See Figure 1a.
3. Connect the Interface Pod to the Evaluation Board using the 14-pin connector (J4) as shown in Figure 1b.
4. VSEL/PG Jumper (J2) factory installed for VSEL0 operation.
5. EN Jumper (J1) factory installed to OFF position. Move to EN position to enable device.
6. Kelvin connected input and output voltage sense points (VIN\_S, VOUT\_S) are provided. Measure relative to AGND

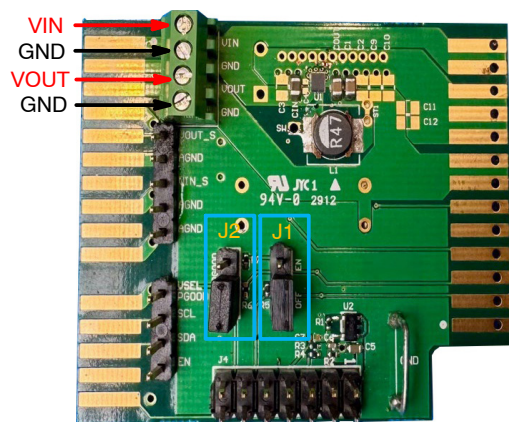

a)



b)

Figure 1. Evaluation Board Connection Diagram

## GUI INSTALLATION

### Installation

- a. Run the installer\_FAN53555.exe.
- b. Follow the steps as shown in the dialog box for setup.

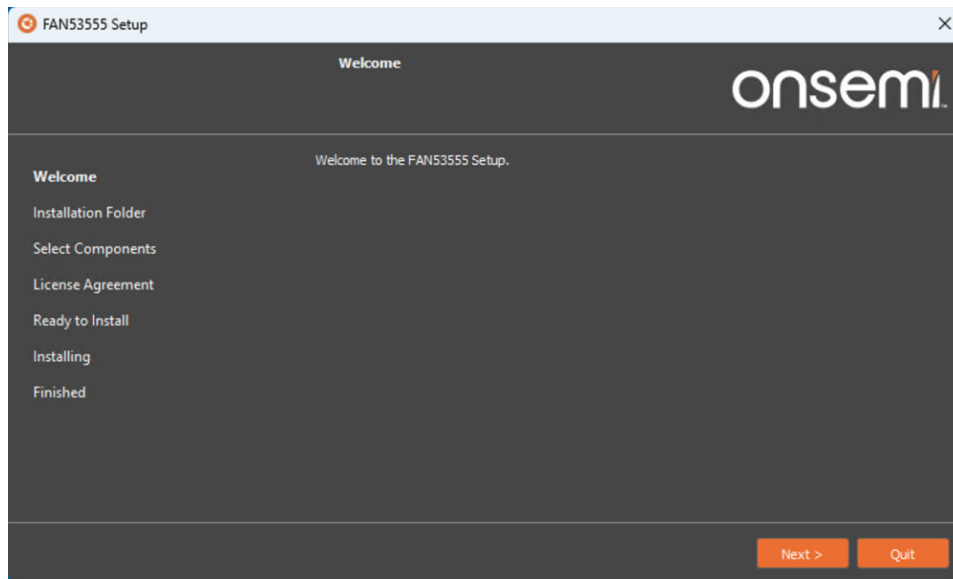

Figure 2. FAN53555 GUI Installation

- c. When prompted for Selecting Components, please check the box for PIC POD Driver to install appropriate drivers needed for USB Interface POD.

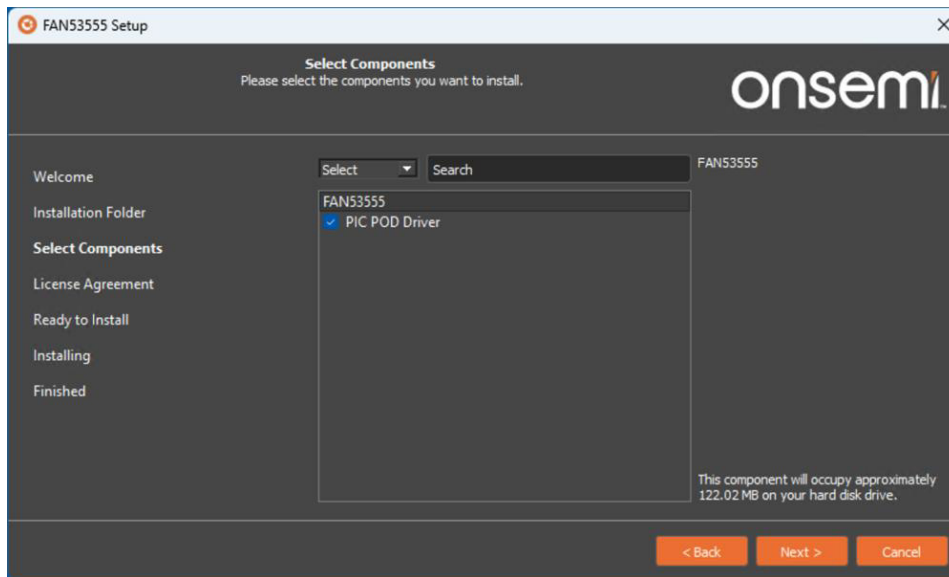

Figure 3. FAN53555 GUI Component Selection

- d. Once all steps have been completed, it will start installing the GUI.

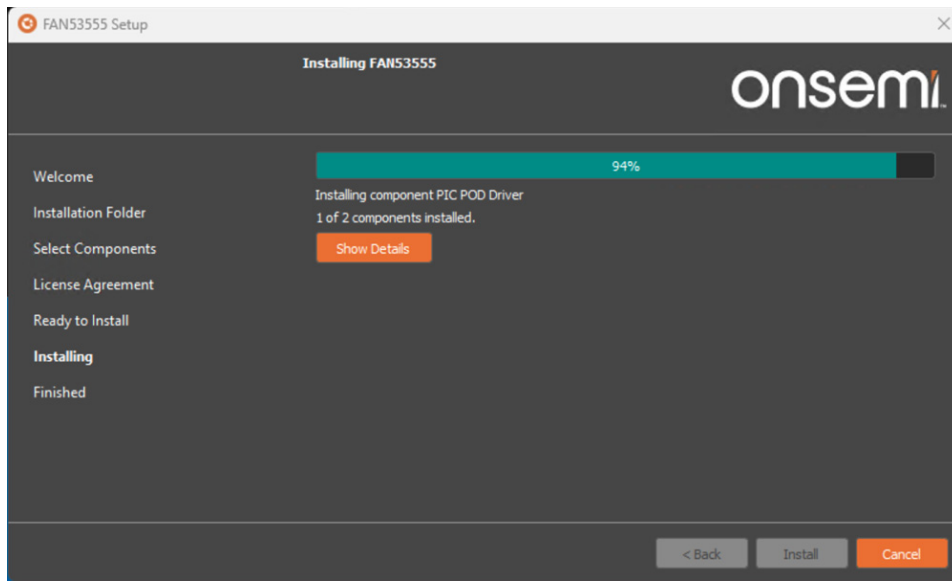

Figure 4. FAN53555 GUI Installation Update

- e. Once the installation is complete, FAN53555 GUI will open automatically. This may take a few seconds.
- f. You can find the installed GUI at this path:  
C:\Users\\*\*\*\*\*\onsemi\FAN53555.

g. Below is a screen shot of the FAN53555 GUI that is used to communicate via I<sup>2</sup>C.

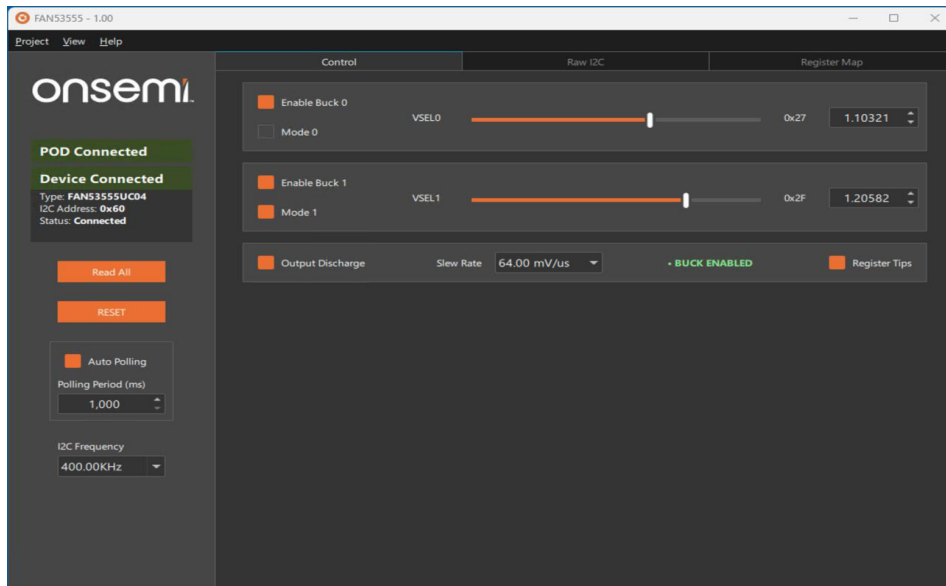

Figure 5. FAN53555 GUI Interface

GUI OVERVIEW

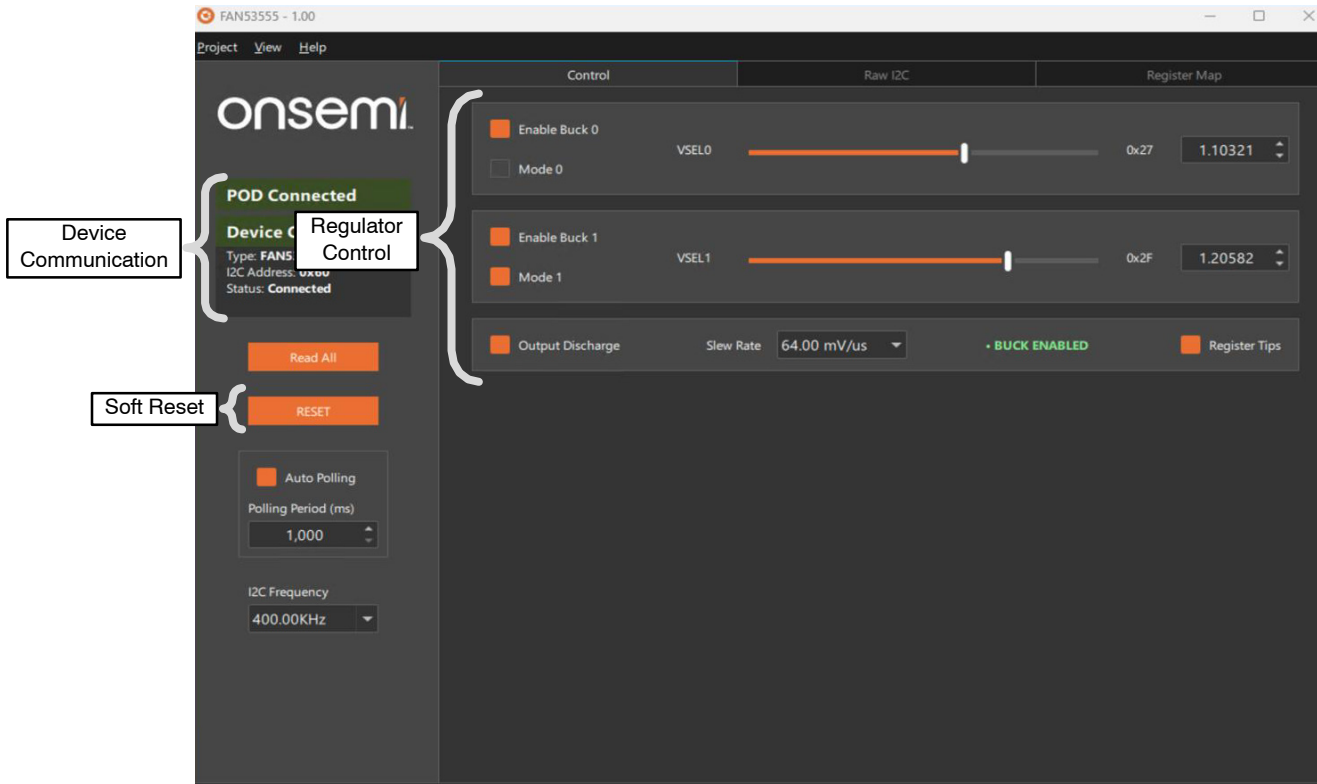

Figure 6. FAN53555 GUI Interface

**Regulator Control**

- a. *Software Enable* or disable device. Depending on jumper position of VSEL (J2).
- b. *Mode* forces device to operate in Forced PWM Mode when selected.
- c. *Output Discharge* enables/disables 160  $\Omega$  output discharge resistance in shutdown.

- d. *Register Tips* provides pop-ups containing register information when hovering over interface controls.

**Device Communication**

- a. the connection status and I<sup>2</sup>C address of the device.

**Soft Reset**

- a. Soft Reset resets the device to its default register values.

REGISTER MAP PANEL

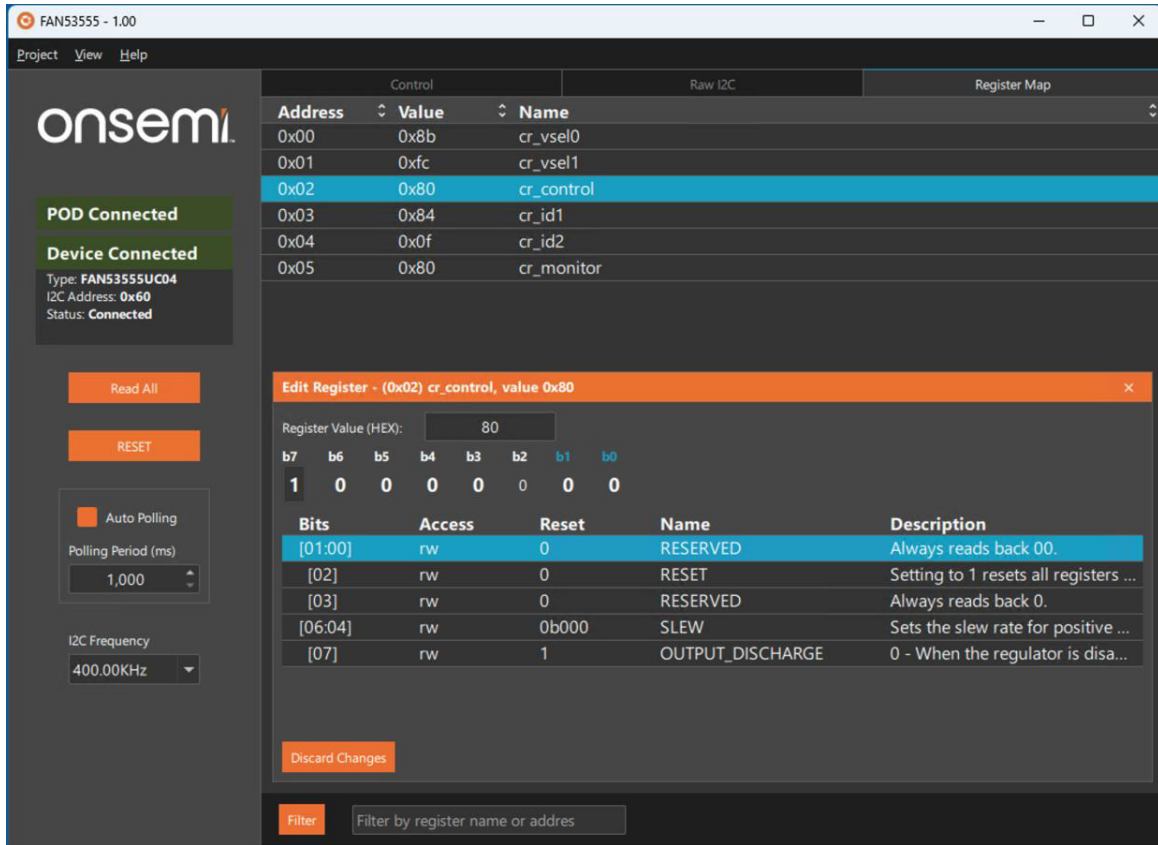

Figure 7. GUI Register Map Panel

**Register Map**

Register Map allows control of individual bits of each Register.

*Discard Changes:* This option will revert the changes made by the user to the current register.

**Edit Register Window**

By double clicking on each Register, the “Edit Register” window will pop-up. Register value can be changed from this window.

RAW I<sup>2</sup>C PANEL

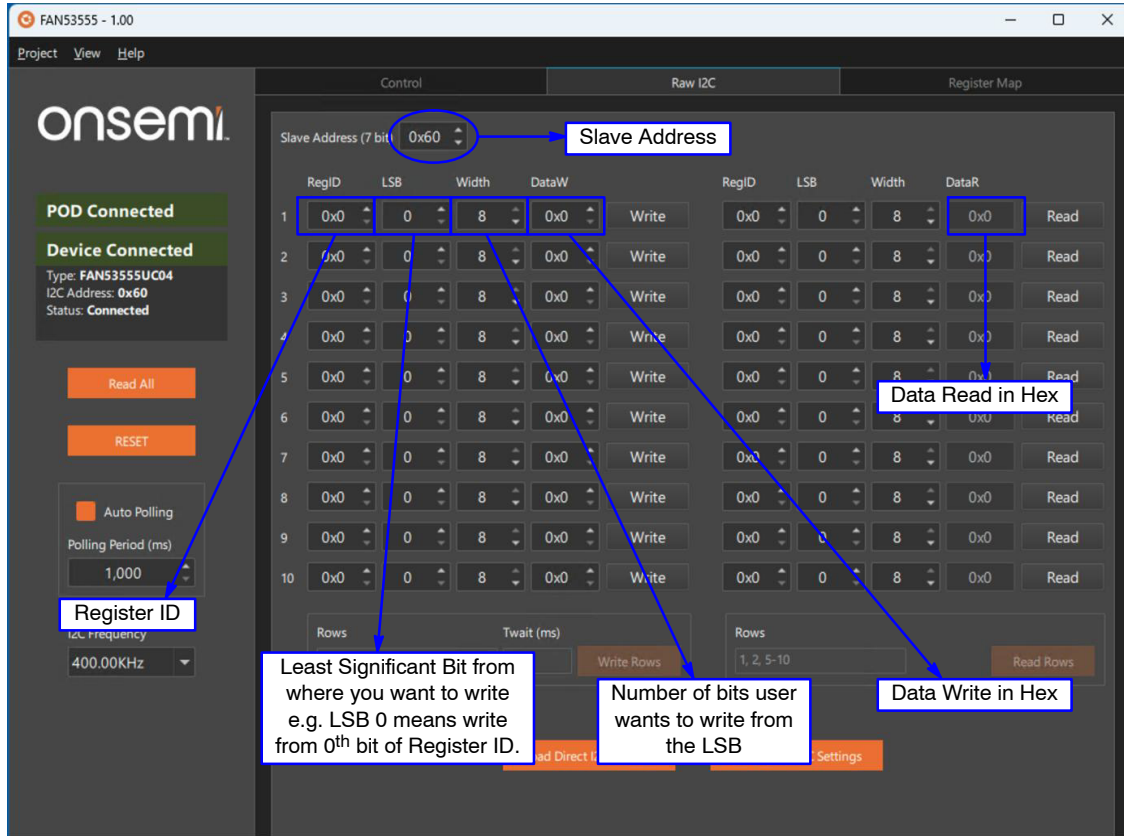

Figure 8a. GUI Raw I<sup>2</sup>C Panel

Raw I<sup>2</sup>C Panel allows the user to write to or read from the known Slave Address with Hex values of data & Register info.

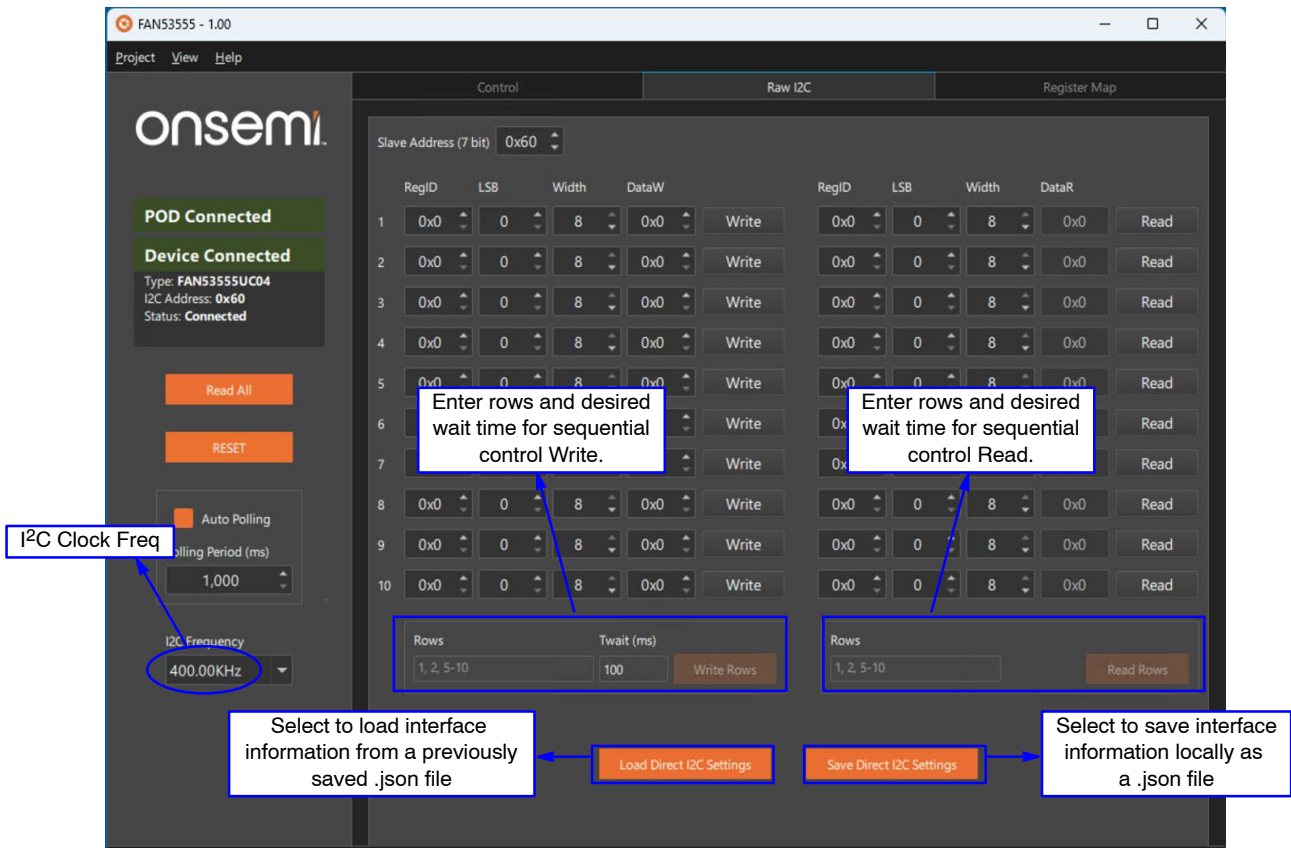

Figure 8b. GUI Raw I2C Panel

GUI has features to select I2C Clock Frequency, write/read registers sequentially, and save/load complete settings to/from .json file.

Communication Error: If Slave-Address is not correct or communication with respective Slave Address fails it will give error on Write or Read.

SCHEMATIC

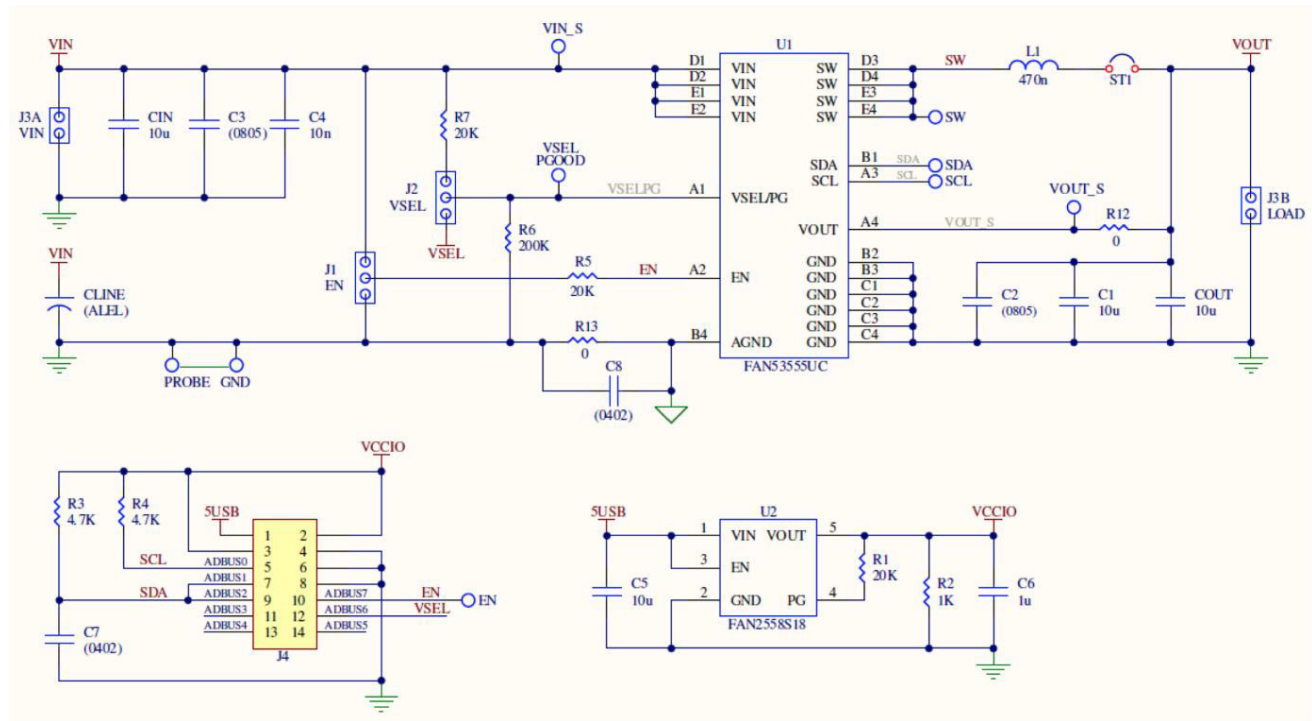

Figure 8. Evaluation Board Schematic

# EVBUM2953/D

## BILL OF MATERIALS

Table 2. BILL OF MATERIALS

FAN53555UC_3_BOM_1			
REF	QTY	DESCRIPTION	MANUFACTURER / NUMBER
U1	1	IC, FAN53555_xx (WLCSP 20)	Fairchild FAN53555UCxx
U2	1	IC, FAN2558, 1.8V LDO, SOT2	Fairchild FAN2558S18
L1 when xx=08, 09, 24	1	330nH, 2x1.6x1.2, 20mΩ	TOKO DFR201612 C33N
		330nH, 2x1.6x1.2, 20mΩ	CYNTEC PIFE20161B-R33MS-39
<b>L1</b>	<b>1</b>	<b>330nH, 20%, 13mΩ, 7.5A</b>	<b>MAG LAYERS MMD-04ABNR33M</b>
CIN	1	10uf, 10V, 10%, X7R, 0805 or 22uF, 10V, 10%, X5R, 0805	Murata GRM21BR71A106K DigiKey 490-3905-1
COUT, C1(when xx=08, 09, 24)	2	22uF, 6.3V, X5R, 0603	C1608X5RJ226M
COUT, C1	2	<b>22uF, 10V, 10%, X5R, 0805</b>	<b>Murata GRM21BR61A226M</b>
C4	1	10nf, 25V, 10%, X7R, 0402	DigiKey PCC2270
C5	1	10uf, 6.3V, 10%, X5R, 0603	Murata GRM188R60J106M DigiKey 490-3896
C6	1	1.0uf, 10V, 10%, X5R, 0402	Murata GRM155R61A105K DigiKey 490-3890-1
R1, R5, R7	3	20K, 5%, 0402	DigiKey P20K J
R2	1	1.0K, 5%, 0402	DigiKey P1.0K J
R3, R4	2	4.53K, 1%, 0402	DigiKey P4.53K L
R6(not installed when xx=03)	1	200K, 5%, 0402	DigiKey P200K J
R12, R13	2	0Ω, 0402	DigiKey P0R0 J

# EVBUM2953/D

## REVISION HISTORY

Revision	Description of Changes	Date
0	Evaluation Board User's Manual creation.	4/7/2026

**onsemi**, **Onsemi**, and other names, marks, and brands are registered and/or common law trademarks of Semiconductor Components Industries, LLC dba "**onsemi**" or its affiliates and/or subsidiaries in the United States and/or other countries. **onsemi** owns the rights to a number of patents, trademarks, copyrights, trade secrets, and other intellectual property. A listing of **onsemi**'s product/patent coverage may be accessed at [www.onsemi.com/site/pdf/Patent-Marking.pdf](http://www.onsemi.com/site/pdf/Patent-Marking.pdf). **onsemi** is an Equal Opportunity/Affirmative Action Employer. This literature is subject to all applicable copyright laws and is not for resale in any manner.

The evaluation board/kit (research and development board/kit) (hereinafter the "board") is not a finished product and is not available for sale to consumers. The board is only intended for research, development, demonstration and evaluation purposes and will only be used in laboratory/development areas by persons with an engineering/technical training and familiar with the risks associated with handling electrical/mechanical components, systems and subsystems. This person assumes full responsibility/liability for proper and safe handling. Any other use, resale or redistribution for any other purpose is strictly prohibited.

**THE BOARD IS PROVIDED BY ONSEMI TO YOU "AS IS" AND WITHOUT ANY REPRESENTATIONS OR WARRANTIES WHATSOEVER. WITHOUT LIMITING THE FOREGOING, ONSEMI (AND ITS LICENSORS/SUPPLIERS) HEREBY DISCLAIMS ANY AND ALL REPRESENTATIONS AND WARRANTIES IN RELATION TO THE BOARD, ANY MODIFICATIONS, OR THIS AGREEMENT, WHETHER EXPRESS, IMPLIED, STATUTORY OR OTHERWISE, INCLUDING WITHOUT LIMITATION ANY AND ALL REPRESENTATIONS AND WARRANTIES OF MERCHANTABILITY, FITNESS FOR A PARTICULAR PURPOSE, TITLE, NON-INFRINGEMENT, AND THOSE ARISING FROM A COURSE OF DEALING, TRADE USAGE, TRADE CUSTOM OR TRADE PRACTICE.**

**onsemi** reserves the right to make changes without further notice to any board.

You are responsible for determining whether the board will be suitable for your intended use or application or will achieve your intended results. Prior to using or distributing any systems that have been evaluated, designed or tested using the board, you agree to test and validate your design to confirm the functionality for your application. Any technical, applications or design information or advice, quality characterization, reliability data or other services provided by **onsemi** shall not constitute any representation or warranty by **onsemi**, and no additional obligations or liabilities shall arise from **onsemi** having provided such information or services.

**onsemi** products including the boards are not designed, intended, or authorized for use in life support systems, or any FDA Class 3 medical devices or medical devices with a similar or equivalent classification in a foreign jurisdiction, or any devices intended for implantation in the human body. You agree to indemnify, defend and hold harmless **onsemi**, its directors, officers, employees, representatives, agents, subsidiaries, affiliates, distributors, and assigns, against any and all liabilities, losses, costs, damages, judgments, and expenses, arising out of any claim, demand, investigation, lawsuit, regulatory action or cause of action arising out of or associated with any unauthorized use, even if such claim alleges that **onsemi** was negligent regarding the design or manufacture of any products and/or the board.

This evaluation board/kit does not fall within the scope of the European Union directives regarding electromagnetic compatibility, restricted substances (RoHS), recycling (WEEE), FCC, CE or UL, and may not meet the technical requirements of these or other related directives.

FCC WARNING – This evaluation board/kit is intended for use for engineering development, demonstration, or evaluation purposes only and is not considered by **onsemi** to be a finished end product fit for general consumer use. It may generate, use, or radiate radio frequency energy and has not been tested for compliance with the limits of computing devices pursuant to part 15 of FCC rules, which are designed to provide reasonable protection against radio frequency interference. Operation of this equipment may cause interference with radio communications, in which case the user shall be responsible, at its expense, to take whatever measures may be required to correct this interference.

**onsemi** does not convey any license under its patent rights nor the rights of others.

LIMITATIONS OF LIABILITY: **onsemi** shall not be liable for any special, consequential, incidental, indirect or punitive damages, including, but not limited to the costs of requalification, delay, loss of profits or goodwill, arising out of or in connection with the board, even if **onsemi** is advised of the possibility of such damages. In no event shall **onsemi**'s aggregate liability from any obligation arising out of or in connection with the board, under any theory of liability, exceed the purchase price paid for the board, if any.

The board is provided to you subject to the license and other terms per **onsemi**'s standard terms and conditions of sale. For more information and documentation, please visit [www.onsemi.com](http://www.onsemi.com).

## ADDITIONAL INFORMATION

### TECHNICAL PUBLICATIONS:

Technical Library: [www.onsemi.com/design/resources/technical-documentation](http://www.onsemi.com/design/resources/technical-documentation)  
onsemi Website: [www.onsemi.com](http://www.onsemi.com)

ONLINE SUPPORT: [www.onsemi.com/support](http://www.onsemi.com/support)

For additional information, please contact your local Sales Representative at [www.onsemi.com/support/sales](http://www.onsemi.com/support/sales)