



## NCV6323C/D Evaluation Board User's Manual

3 MHz, 2 A, High Efficiency, Low Ripple, Adjustable Output Voltage, Synchronous Buck Converter

ON Semiconductor®

[www.onsemi.com](http://www.onsemi.com)

### EVAL BOARD USER'S MANUAL

#### Overview

This document is a manual file for a demo board of the NCV6323C/D, which includes demo board schematics, bill of materials, PCB layout, jumper setup, and test procedure.

#### About NCV6323C/D

The NCV6323C/D, a family of synchronous buck converters, which is optimized to supply different sub systems of portable applications powered by one cell Li-ion or three cell Alkaline/NiCd/NiMH batteries. The devices are able to deliver up to 2 A on an external adjustable voltage range from 0.6 V to 3.3 V. Operation with 3 MHz switching frequency allows employing small size inductor and capacitors. Input supply voltage feed-forward control is employed to deal with wide input voltage range. Synchronous rectification PWM offers improved system efficiency. The NCV6323C is in a space saving, low profile  $2.0 \times 2.0 \times 0.75$  mm WDFN-8 package.

#### Features

- 2.5 V to 5.5 V Input Voltage Range
- External Adjustable Voltage
- Up to 2 A Output Current

- 3 MHz Switching Frequency
- PWM Synchronous Rectification
- Enable Input
- Power Good Output
- Soft Start
- Over Current Protection
- Active Discharge When Disabled. Hi-Z Version Available upon Request
- Thermal Shutdown Protection
- WDFN-8,  $2 \times 2$  mm, 0.5 mm Pitch Package
- Maximum 0.8 mm Height for Super Thin Applications

#### Typical Applications

- Automotive Clusters
- Automotive Cameras (Rear, Front, Side View)
- Automotive ADAS
- Automotive Multimedia Systems
- Point Of Load
- Game and Entertainment System

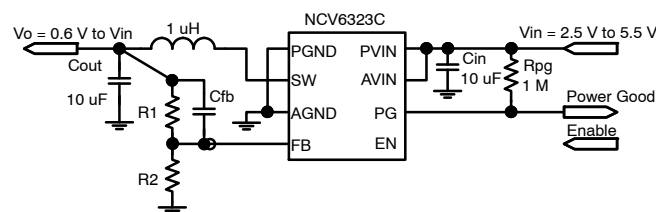

Figure 1. Typical Application Circuits

# NCV6323GEVB

**Table 1. PIN DESCRIPTION**

Pin	Name	Type	Description
1	PGND	Power Ground	Power Ground for power, analog blocks. Must be connected to the system ground.
2	SW	Power Output	Switch Power pin connects power transistors to one end of the inductor.
3	AGND	Analog Ground	Analog Ground analog and digital blocks. Must be connected to the system ground.
4	FB	Analog Input	Feedback Voltage from the buck converter output. This is the input to the error amplifier. For fixed output devices, this pin is directly connected to the output capacitor; For external adjustable output devices, this pin is connected to the resistor divider network between the output and AGND.
5	EN	Digital Input	Enable of the IC. High level at this pin enables the device. Low level at this pin disables the device.
6	PG	Digital Output	PG pin is open drain output. Low level at this pin indicates the device is not in power good, while high impedance at this pin indicates the device is in power good.
7	AVIN	Analog Input	Analog Supply. This pin is the analog and the digital supply of the device. An optional 1 $\mu$ F or larger ceramic capacitor bypasses this input to the ground. This capacitor should be placed as close as possible to this input.
8	PVIN	Power Input	Power Supply Input. This pin is the power supply of the device. A 10 $\mu$ F or larger ceramic capacitor must bypass this input to the ground. This capacitor should be placed as close a possible to this input.
9	PAD	Exposed Pad	Exposed Pad. Must be soldered to system ground to achieve power dissipation performances. This pin is internally unconnected

**Table 2. MAXIMUM RATINGS**

Rating	Symbol	Value		Unit
		Min	Max	
Input Supply Voltage to GND	$V_{PVIN}, V_{AVIN}$	-0.3	7.0	V
Switch Node to GND	$V_{SW}$	-0.3	7.0	V
EN, PG to GND	$V_{EN}, V_{PG}$	-0.3	7.0	V
FB to GND	$V_{FB}$	-0.3	7.0	V
Human Body Model (HBM) ESD Rating are (Note 1)	ESD HBM	-	2,000	V
Machine Model (MM) ESD Rating are (Note 1)	ESD MM	-	200	V
Latch up Current: (Note 2) All pins, except digital pins Digital pins	$I_{LU}$	-100 -10	100 10	mA
Operating Junction Temperature Range	$T_J$	-40	125	$^{\circ}$ C
Operating Ambient Temperature Range	$T_A$	-40	85	$^{\circ}$ C
Storage Temperature Range	$T_{STG}$	-55	150	$^{\circ}$ C
Thermal Resistance Junction-to-Top Case (Note 4)	$R_{\theta JC}$	12		$^{\circ}$ C/W
Thermal Resistance Junction-to-Board (Note 4)	$R_{\theta JB}$	30		$^{\circ}$ C/W
Thermal Resistance Junction-to-Ambient (Note 4)	$R_{\theta JA}$	62		$^{\circ}$ C/W
Power Dissipation (Note 5)	$P_D$	1.6		W
Moisture Sensitivity Level (Note 6)	MSL	1		-

Stresses exceeding those listed in the Maximum Ratings table may damage the device. If any of these limits are exceeded, device functionality should not be assumed, damage may occur and reliability may be affected.

- This device series contains ESD protection and passes the following tests:  
Human Body Model (HBM)  $\pm 2.0$  kV per JEDEC standard: JESD22-A114.  
Machine Model (MM)  $\pm 200$  V per JEDEC standard: JESD22-A115.
- Latch up Current per JEDEC standard: JESD78 class II.
- The thermal shutdown set to 150 $^{\circ}$ C (typical) avoids potential irreversible damage on the device due to power dissipation.
- The thermal resistance values are dependent of the PCB heat dissipation. Board used to drive these data was an 80 x 50 mm NCV6323EVB board. It is a multilayer board with 1 once internal power and ground planes and 2-once copper traces on top and bottom of the board. If the copper traces of top and bottom are 1 once too,  $R_{\theta JC} = 11^{\circ}$ C/W,  $R_{\theta JB} = 30^{\circ}$ C/W, and  $R_{\theta JA} = 72^{\circ}$ C/W.
- The maximum power dissipation ( $P_D$ ) is dependent on input voltage, maximum output current and external components selected.
- Moisture Sensitivity Level (MSL): 1 per IPC/JEDEC standard: J-STD-020A.

# NCV6323GEVB

## Electrical Characteristics

For electrical characteristics, please refer to NCV6323C/D datasheet available on website: <http://www.onsemi.com>.

## Schematic of Demo Board

A schematic of NCV6323C/D evaluation board is shown in Figure 2, which is for a typical application with 1.8 V output voltage. It is flexible to configure the board. Please refer to Jumper Configuration for details.

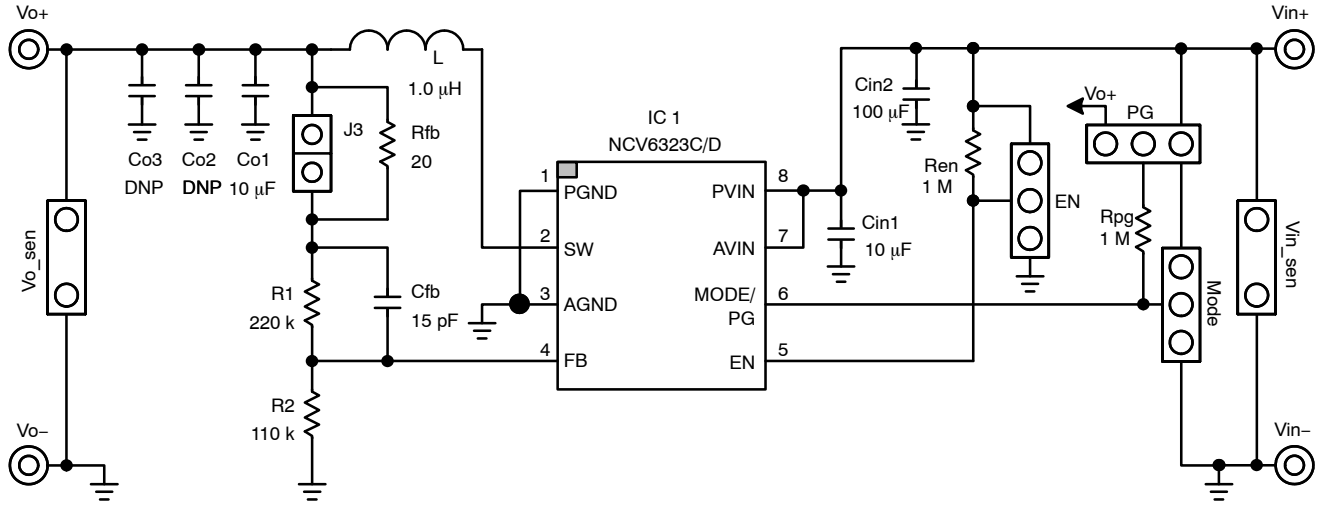

Figure 2. Schematic of NCV6323C/D Evaluation Board

Table 3. BILL OF MATERIALS OF EVALUATION BOARD

Item	Part Reference	Description	Package	Part Number	Manufacturer	Qty
1	IC1	3 MHz, 2 A, Synchronous Buck Converter	WDFN-8 2.0 × 2.0 × 0.75 mm	NCV63xyC/D	ON Semiconductor	1
2	Cin1	MLCC Cap 10 V, 10 µF, X5R, ±20%	0805	GRM21BR61A106KE19	muRata	1
3	Cin2	MLCC Cap 6.3 V, 100 µF, X5R, ±20%	1210	GRM32ER60J107ME20	muRata	1
4	Co1	MLCC Cap 6.3 V, 10 µF, X5R, ±20%	0603	GRM188R60J106ME47	muRata	1
5	L	Power Choke 1.0 µH, ±30%, 2450 mA, 30 mΩ	4.0 × 3.5 × 1.65 mm	LQH44PN1R0NP0	muRata	1
6	Ren, Rpg	Thick Film Chip Resistors, 1 MΩ, ±5%, 0.1 W	0603	ERJ3GEYJ105V	Panasonic	2
7	R1	Thick Film Chip Resistors, 220 kΩ, ±1%, 0.1 W	0603	ERA3AEB224V	Panasonic	1
8	R2	Thick Film Chip Resistors, 110 kΩ, ±1%, 0.1 W	0603	ERA3AEB114V	Panasonic	1
9	Cfb	MLCC, 15 pF, 50 V, 0603	0603	ECJ1VC1H150J	Panasonic	1
10	Rfb	Thick Film Chip Resistors, 20 Ω, ±1%, 0.1 W	0603	ERA3AEB200V	Panasonic	1



# NCV6323GEVB

## Connections and Jumper Setup

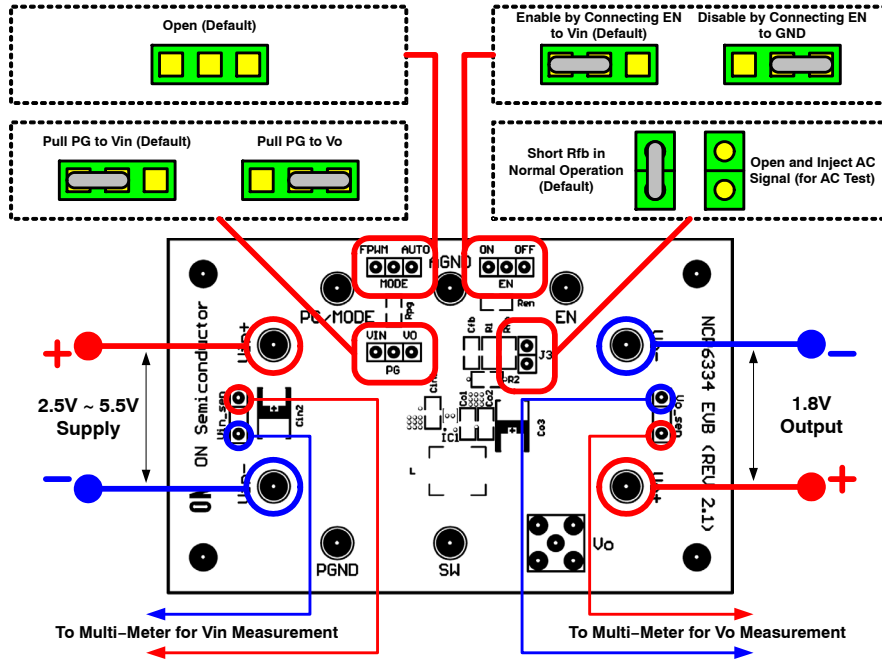
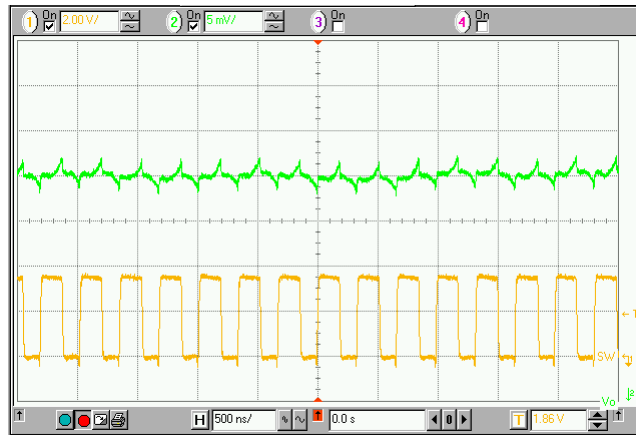

Figure 4. Connections and Jumper Setup of NCV6323C/D Evaluation Board

## NCV6323GEVB

### Test Procedure of Evaluation Board

1. Prepare equipments as below list.
  - a. DC power supply
  - b. Electronic load
  - c. Multimeters
  - d. Oscilloscope
2. Check jumper setup to make sure it is a right default configuration for the device under test.
3. Set the power supply to 3.6 V with a current limit higher than 1 A, and then disable the output of the power supply.
4. Connect the power supply to the evaluation board's connectors Vin+ and Vin-.
5. Disable output of the electronic load and connect it to the evaluation board's connectors Vo+ and Vo-.
6. Enable the output of the power supply and check the 1.8 V output voltage of the evaluation board.
7. Set the electronic load to 10 mA and enable its output. Typical input supply current is about 6 mA.
8. Monitor and verify the output voltage value is in the 1.8 V range.
9. Increase the electronic load to 1.0 A. Typical input supply current is about 565 mA.
10. Monitor the output voltage and SW node signal using the oscilloscope. The converter should operate in CCM with similar waveforms as shown in Figure 5(b). The switching frequency is about 3 MHz.
11. After the test is done, make sure to disable the output of power supply before remove power connectors to protect the device from damage caused by possible high voltage spike in input.



$I_o = 1000 \text{ mA}$

Figure 5. Typical Operation Waveforms of NCV6323C/D Evaluation Board

**onsemi**, **Onsemi**, and other names, marks, and brands are registered and/or common law trademarks of Semiconductor Components Industries, LLC dba "**onsemi**" or its affiliates and/or subsidiaries in the United States and/or other countries. **onsemi** owns the rights to a number of patents, trademarks, copyrights, trade secrets, and other intellectual property. A listing of **onsemi**'s product/patent coverage may be accessed at [www.onsemi.com/site/pdf/Patent-Marking.pdf](http://www.onsemi.com/site/pdf/Patent-Marking.pdf). **onsemi** is an Equal Opportunity/Affirmative Action Employer. This literature is subject to all applicable copyright laws and is not for resale in any manner.

The evaluation board/kit (research and development board/kit) (hereinafter the "board") is not a finished product and is not available for sale to consumers. The board is only intended for research, development, demonstration and evaluation purposes and will only be used in laboratory/development areas by persons with an engineering/technical training and familiar with the risks associated with handling electrical/mechanical components, systems and subsystems. This person assumes full responsibility/liability for proper and safe handling. Any other use, resale or redistribution for any other purpose is strictly prohibited.

**THE BOARD IS PROVIDED BY ONSEMI TO YOU "AS IS" AND WITHOUT ANY REPRESENTATIONS OR WARRANTIES WHATSOEVER. WITHOUT LIMITING THE FOREGOING, ONSEMI (AND ITS LICENSORS/SUPPLIERS) HEREBY DISCLAIMS ANY AND ALL REPRESENTATIONS AND WARRANTIES IN RELATION TO THE BOARD, ANY MODIFICATIONS, OR THIS AGREEMENT, WHETHER EXPRESS, IMPLIED, STATUTORY OR OTHERWISE, INCLUDING WITHOUT LIMITATION ANY AND ALL REPRESENTATIONS AND WARRANTIES OF MERCHANTABILITY, FITNESS FOR A PARTICULAR PURPOSE, TITLE, NON-INFRINGEMENT, AND THOSE ARISING FROM A COURSE OF DEALING, TRADE USAGE, TRADE CUSTOM OR TRADE PRACTICE.**

**onsemi** reserves the right to make changes without further notice to any board.

You are responsible for determining whether the board will be suitable for your intended use or application or will achieve your intended results. Prior to using or distributing any systems that have been evaluated, designed or tested using the board, you agree to test and validate your design to confirm the functionality for your application. Any technical, applications or design information or advice, quality characterization, reliability data or other services provided by **onsemi** shall not constitute any representation or warranty by **onsemi**, and no additional obligations or liabilities shall arise from **onsemi** having provided such information or services.

**onsemi** products including the boards are not designed, intended, or authorized for use in life support systems, or any FDA Class 3 medical devices or medical devices with a similar or equivalent classification in a foreign jurisdiction, or any devices intended for implantation in the human body. You agree to indemnify, defend and hold harmless **onsemi**, its directors, officers, employees, representatives, agents, subsidiaries, affiliates, distributors, and assigns, against any and all liabilities, losses, costs, damages, judgments, and expenses, arising out of any claim, demand, investigation, lawsuit, regulatory action or cause of action arising out of or associated with any unauthorized use, even if such claim alleges that **onsemi** was negligent regarding the design or manufacture of any products and/or the board.

This evaluation board/kit does not fall within the scope of the European Union directives regarding electromagnetic compatibility, restricted substances (RoHS), recycling (WEEE), FCC, CE or UL, and may not meet the technical requirements of these or other related directives.

FCC WARNING – This evaluation board/kit is intended for use for engineering development, demonstration, or evaluation purposes only and is not considered by **onsemi** to be a finished end product fit for general consumer use. It may generate, use, or radiate radio frequency energy and has not been tested for compliance with the limits of computing devices pursuant to part 15 of FCC rules, which are designed to provide reasonable protection against radio frequency interference. Operation of this equipment may cause interference with radio communications, in which case the user shall be responsible, at its expense, to take whatever measures may be required to correct this interference.

**onsemi** does not convey any license under its patent rights nor the rights of others.

LIMITATIONS OF LIABILITY: **onsemi** shall not be liable for any special, consequential, incidental, indirect or punitive damages, including, but not limited to the costs of requalification, delay, loss of profits or goodwill, arising out of or in connection with the board, even if **onsemi** is advised of the possibility of such damages. In no event shall **onsemi**'s aggregate liability from any obligation arising out of or in connection with the board, under any theory of liability, exceed the purchase price paid for the board, if any.

The board is provided to you subject to the license and other terms per **onsemi**'s standard terms and conditions of sale. For more information and documentation, please visit [www.onsemi.com](http://www.onsemi.com).

## ADDITIONAL INFORMATION

### TECHNICAL PUBLICATIONS:

Technical Library: [www.onsemi.com/design/resources/technical-documentation](http://www.onsemi.com/design/resources/technical-documentation)  
onsemi Website: [www.onsemi.com](http://www.onsemi.com)

ONLINE SUPPORT: [www.onsemi.com/support](http://www.onsemi.com/support)

For additional information, please contact your local Sales Representative at [www.onsemi.com/support/sales](http://www.onsemi.com/support/sales)