

# Silicon Carbide (SiC) Module - EliteSiC, 6 mΩ, 1200 V, SiC M3 MOSFET, 2-PACK Half Bridge Topology, F1 Package

## NXH006P120M3F1PG

The NXH006P120M3F1PG is a power module containing 6 mΩ / 1200 V SiC MOSFET half-bridge and a thermistor with Al<sub>2</sub>O<sub>3</sub> DBC in an F1 package.

### Features

- 6 mΩ / 1200 V M3S SiC MOSFET Half-Bridge
- Al<sub>2</sub>O<sub>3</sub> DBC
- Thermistor
- Press-Fit Pins
- These Devices are Pb-Free, Halide Free and are RoHS Compliant

### Typical Applications

- Solar Inverter
- Uninterruptible Power Supplies
- Electric Vehicle Charging Stations
- Industrial Power

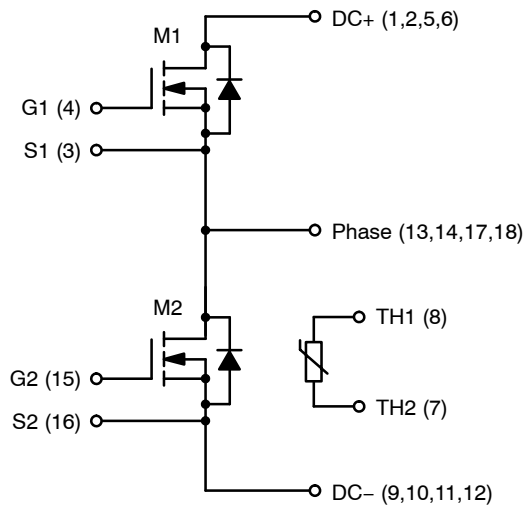
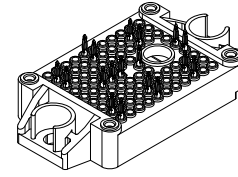
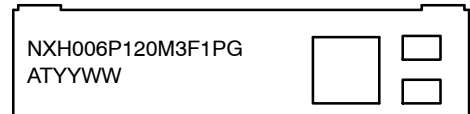

Figure 1. Schematic Diagram



PIM18 33.8x42.5 (PRESS FIT)  
CASE 180BW

### MARKING DIAGRAM



NXH006P120M3F1PG = Specific Device Code  
AT = Assembly & Test Site Code  
YYWW = Year and Work Week Code

### PIN CONNECTIONS

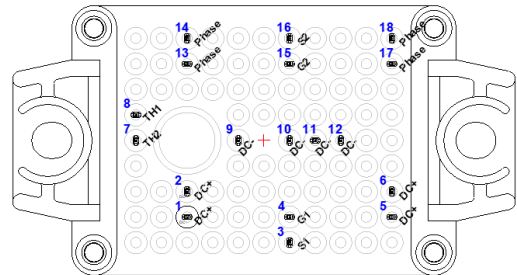

See Pin Function Description for pin names

### ORDERING INFORMATION

See detailed ordering and shipping information on page 4 of this data sheet.

# NXH006P120M3F1PG

## PIN FUNCTION DESCRIPTION

Pin	Name	Description
1	DC+	DC Positive Bus connection
2	DC+	DC Positive Bus connection
3	S1	M1 Kelvin Emitter (High side switch)
4	G1	M1 Gate (High side switch)
5	DC+	DC Positive Bus connection
6	DC+	DC Positive Bus connection
7	TH2	Thermistor Connection 2
8	TH1	Thermistor Connection 1
9	DC-	DC Negative Bus connection
10	DC-	DC Negative Bus connection
11	DC-	DC Negative Bus connection
12	DC-	DC Negative Bus connection
13	PHASE	Center point of half bridge
14	PHASE	Center point of half bridge
15	G2	M2 Gate (Low side switch)
16	S2	M2 Kelvin Emitter (Low side switch)
17	PHASE	Center point of half bridge
18	PHASE	Center point of half bridge

# NXH006P120M3F1PG

## MAXIMUM RATINGS

Rating	Symbol	Value	Unit
<b>SiC MOSFET</b>			
Drain-to-Source Voltage	$V_{DSS}$	1200	V
Gate-to-Source Voltage	$V_{GS}$	+22/-10	V
Continuous Drain Current @ $T_C = 80\text{ }^\circ\text{C}$ (Note 2)	$I_D$	200	A
Pulsed Drain Current ( $T_J = 175\text{ }^\circ\text{C}$ , $t_p = 100\text{ }\mu\text{s}$ )	$I_{DM}$	600	A
Maximum Power Dissipation @ $T_C = 80\text{ }^\circ\text{C}$ (Note 2)	$P_{tot}$	333	W
Minimum Operating Junction Temperature	$T_{JMIN}$	-40	$^\circ\text{C}$
Maximum Operating Junction Temperature	$T_{JMAX}$	175	$^\circ\text{C}$

## THERMAL PROPERTIES

Storage Temperature Range	$T_{stg}$	-40 to 150	$^\circ\text{C}$
TIM Layer Thickness	$T_{TIM}$	160 $\pm$ 20	$\mu\text{m}$

## INSULATION PROPERTIES

Isolation Test Voltage, $t = 1\text{ s}$ , 60 Hz	$V_{is}$	4800	$V_{RMS}$
Creepage Distance		12.7	mm
CTI		600	
Substrate Ceramic Material		$\text{Al}_2\text{O}_3$	
Substrate Ceramic Material Thickness		0.32	mm
Substrate Warpage (Note 3)	W	Max 0.18	mm

Stresses exceeding those listed in the Maximum Ratings table may damage the device. If any of these limits are exceeded, device functionality should not be assumed, damage may occur and reliability may be affected.

1. Refer to ELECTRICAL CHARACTERISTICS, RECOMMENDED OPERATING RANGES and/or APPLICATION INFORMATION for Safe Operating parameters
2. Maximum continuous current and power, without switching losses, to reach  $T_J = 175\text{ }^\circ\text{C}$  defined by design based on MOSFET  $R_{DS(ON)}$  and  $R_{\theta JC}$  and not subject to production test
3. Height difference between horizontal plane and substrate copper bottom

## RECOMMENDED OPERATING RANGES

Rating	Symbol	Min	Max	Unit
Module Operating Junction Temperature	$T_J$	-40	150	$^\circ\text{C}$

Functional operation above the stresses listed in the Recommended Operating Ranges is not implied. Extended exposure to stresses beyond the Recommended Operating Ranges limits may affect device reliability.

## ELECTRICAL CHARACTERISTICS ( $T_J = 25\text{ }^\circ\text{C}$ unless otherwise noted)

Parameter	Symbol	Test Conditions	Min	Typ	Max	Unit
<b>SiC MOSFET CHARACTERISTICS</b>						
Zero Gate Voltage Drain Current	$I_{DSS}$	$V_{GS} = 0\text{ V}$ , $V_{DS} = 1200\text{ V}$			300	$\mu\text{A}$
Drain-to-Source On Resistance	$R_{DS(ON)}$	$V_{GS} = 18\text{ V}$ , $I_D = 120\text{ A}$ , $T_J = 25\text{ }^\circ\text{C}$		6.0	9	$\text{m}\Omega$
		$V_{GS} = 18\text{ V}$ , $I_D = 120\text{ A}$ , $T_J = 125\text{ }^\circ\text{C}$		7.5		
		$V_{GS} = 18\text{ V}$ , $I_D = 120\text{ A}$ , $T_J = 150\text{ }^\circ\text{C}$		8.5		
Gate-to-Source Threshold Voltage	$V_{GS(TH)}$	$V_{GS} = V_{DS}$ , $I_D = 80\text{ mA}$	1.8	2.8	4.4	V
Gate Leakage Current	$I_{GSS}$	$V_{GS} = -10\text{ V} / 22\text{ V}$ , $V_{DS} = 0\text{ V}$	-400		400	nA
Input Capacitance	$C_{ISS}$	$V_{DS} = 800\text{ V}$ , $V_{GS} = 0\text{ V}$ , $f = 100\text{ kHz}$		13715		pF
Reverse Transfer Capacitance	$C_{RSS}$			52		
Output Capacitance	$C_{OSS}$			598		

# NXH006P120M3F1PG

## ELECTRICAL CHARACTERISTICS ( $T_J = 25\text{ }^\circ\text{C}$ unless otherwise noted) (continued)

Parameter	Symbol	Test Conditions	Min	Typ	Max	Unit
<b>SiC MOSFET CHARACTERISTICS</b>						
Total Gate Charge	$Q_{G(TOTAL)}$	$V_{DS} = 800\text{ V}, V_{GS} = -5/20\text{ V}, I_D = 100\text{ A}$		622		nC
Gate-to-Source Charge	$Q_{GS}$			91		nC
Gate-to-Drain Charge	$Q_{GD}$			120		nC
Turn-on Delay Time	$t_{d(on)}$	$T_J = 25\text{ }^\circ\text{C}$ $V_{DS} = 800\text{ V}, I_D = 120\text{ A}$ $V_{GS} = -5\text{ V} / 18\text{ V}, R_G = 1.8\text{ }\Omega$		43		ns
Rise Time	$t_r$			14		
Turn-off Delay Time	$t_{d(off)}$			149		
Fall Time	$t_f$			13		
Turn-on Switching Loss per Pulse	$E_{ON}$			3.04		mJ
Turn-off Switching Loss per Pulse	$E_{OFF}$			0.24		
Turn-on Delay Time	$t_{d(on)}$		$T_J = 150\text{ }^\circ\text{C}$ $V_{DS} = 800\text{ V}, I_D = 120\text{ A}$ $V_{GS} = -5\text{ V} / 18\text{ V}, R_G = 1.8\text{ }\Omega$		40	
Rise Time	$t_r$			13		
Turn-off Delay Time	$t_{d(off)}$			160		
Fall Time	$t_f$			13.5		
Turn-on Switching Loss per Pulse	$E_{ON}$			3.71		mJ
Turn-off Switching Loss per Pulse	$E_{OFF}$			0.3		
Diode Forward Voltage	$V_{SD}$	$I_D = 120\text{ A}, T_J = 25\text{ }^\circ\text{C}$		5.3	7.5	V
		$I_D = 120\text{ A}, T_J = 125\text{ }^\circ\text{C}$		4.91		
		$I_D = 120\text{ A}, T_J = 150\text{ }^\circ\text{C}$		4.82		
Thermal Resistance – Chip-to-Case	$R_{thJC}$	M1, M2 (Note 4)		0.21	0.28	$^\circ\text{C}/\text{W}$
Thermal Resistance – Chip-to-Heatsink	$R_{thJH}$	Thermal grease, Thickness = 2 Mil +2%, A = 2.8 W/mK (Note 5)		0.43		$^\circ\text{C}/\text{W}$

## Thermistor Characteristics

Nominal Resistance	$R_{25}$	$T_{NTC} = 25\text{ }^\circ\text{C}$		5		k $\Omega$
Nominal Resistance	$R_{100}$	$T_{NTC} = 100\text{ }^\circ\text{C}$		493		$\Omega$
Nominal Resistance	$R_{150}$	$T_{NTC} = 150\text{ }^\circ\text{C}$		159.5		$\Omega$
Deviation of $R_{100}$	$\Delta R/R$	$T_{NTC} = 100\text{ }^\circ\text{C}$	-5		5	%
Power Dissipation – Recommended Limit	$P_D$	0.15 mA, non-self-heating effect		0.1		mW
Power Dissipation – Absolute Maximum	$P_D$	5 mA		34.2		mW
Power Dissipation Constant				1.4		mW/K
B-value		B(25/50), tolerance $\pm 2\%$		3375		K
B-value		B(25/100), tolerance $\pm 2\%$		3436		K

Product parametric performance is indicated in the Electrical Characteristics for the listed test conditions, unless otherwise noted. Product performance may not be indicated by the Electrical Characteristics if operated under different conditions.

4. Test method compliant with MIL STD 883-1012.1, Cosmetic oxidation and discoloration on the DBC surface allowed
5. Defined by thermal simulation

## ORDERING INFORMATION

Orderable Part Number	Marking	Package	Shipping
NXH006P120M3F1PG	NXH006P120M3F1PG	F2HALFBR: Case 180BY Press-fit Pins with pre-applied thermal interface material (TIM) (Pb-Free / Halide Free)	20 Units / Blister Tray

# NXH006P120M3F1PG

## TYPICAL CHARACTERISTICS

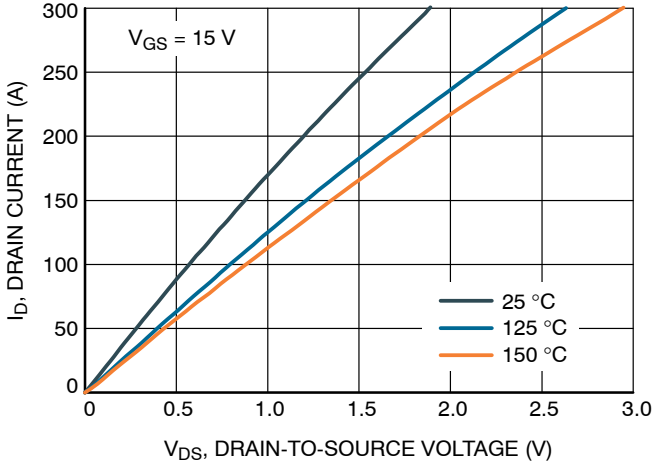

**Figure 2. MOSFET Typical Output Characteristic**

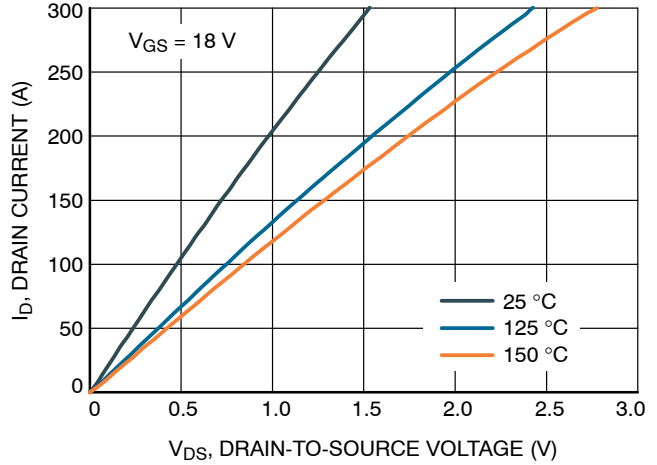

**Figure 3. MOSFET Typical Output Characteristic**

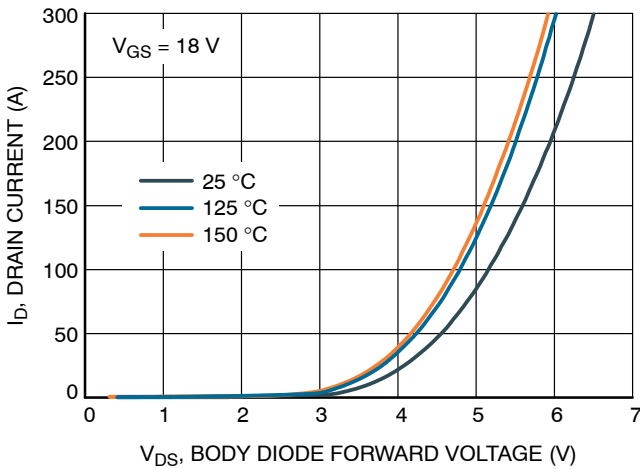

**Figure 4. Body Diode Forward Characteristic**

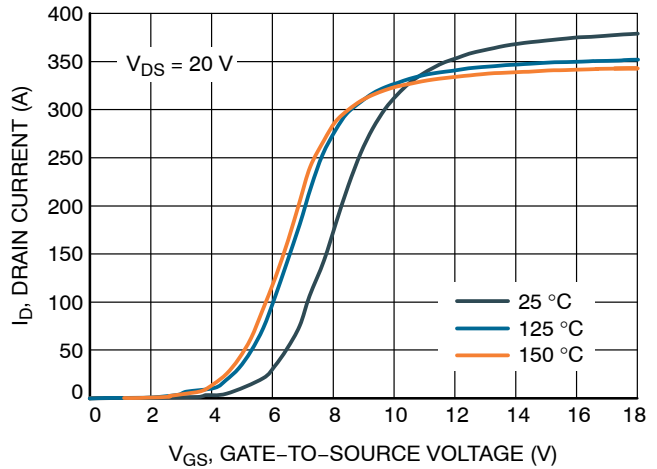

**Figure 5. Transfer Characteristics**

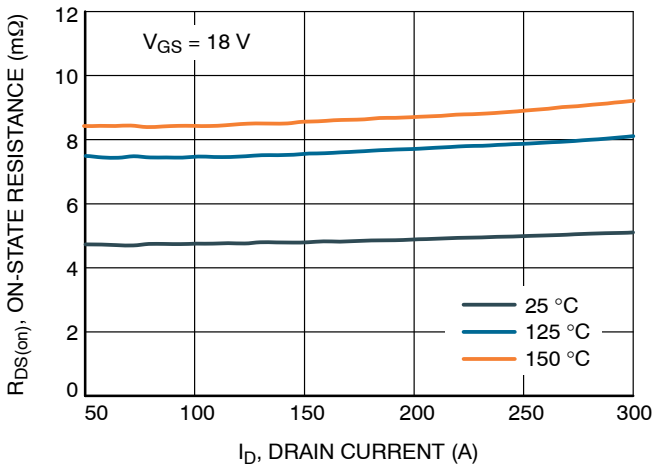

**Figure 6. On-Resistance vs. Drain Current**

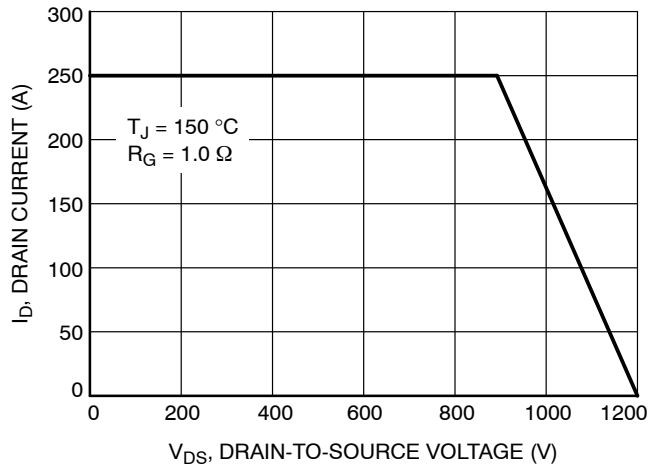

**Figure 7. RBSOA**

# NXH006P120M3F1PG

## TYPICAL CHARACTERISTICS

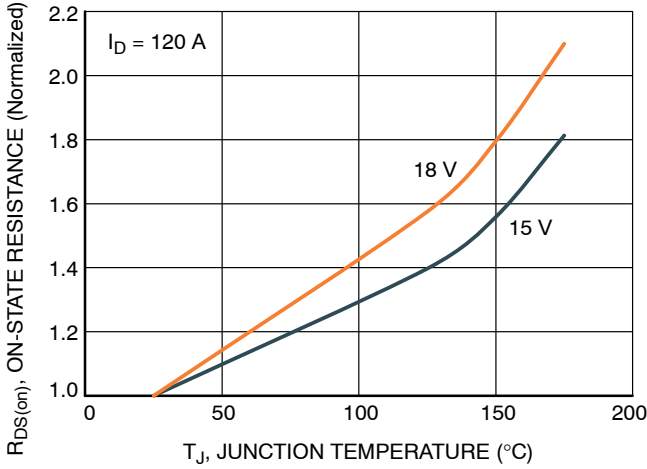

**Figure 8. On-Resistance vs. Junction Temperature (Normalized)**

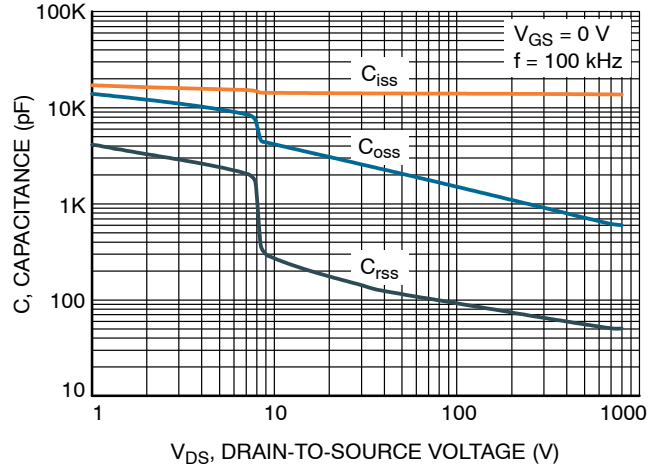

**Figure 9. Capacitance Characteristics**

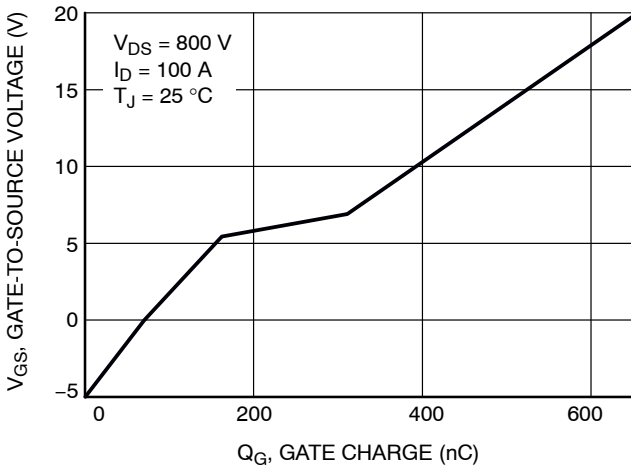

**Figure 10. Gate Charge Characteristics**

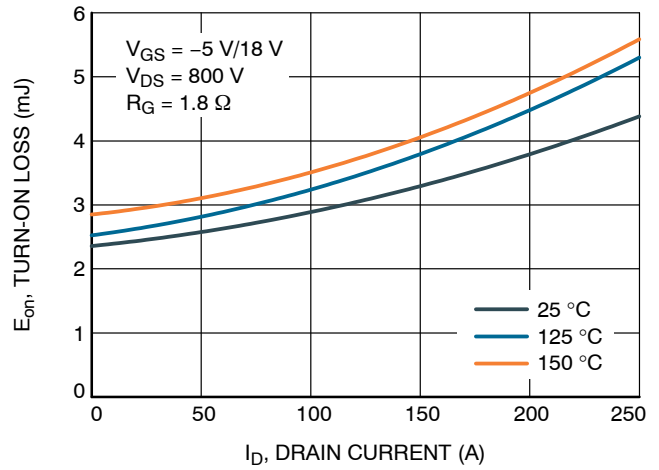

**Figure 11. Typical Switching Loss E<sub>on</sub> vs. Drain Current**

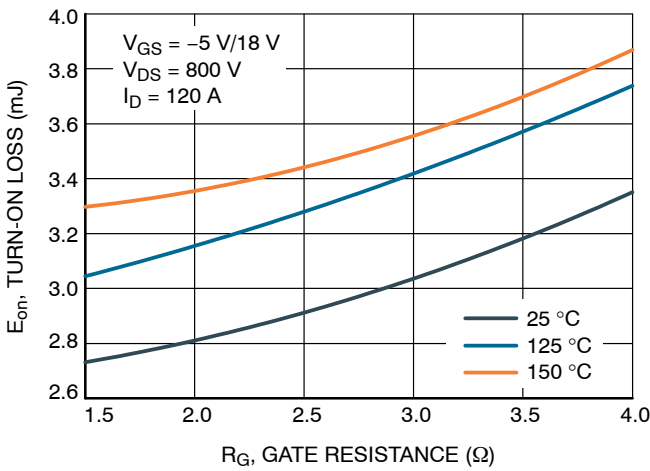

**Figure 12. Typical Switching Loss E<sub>on</sub> vs. R<sub>g</sub>**

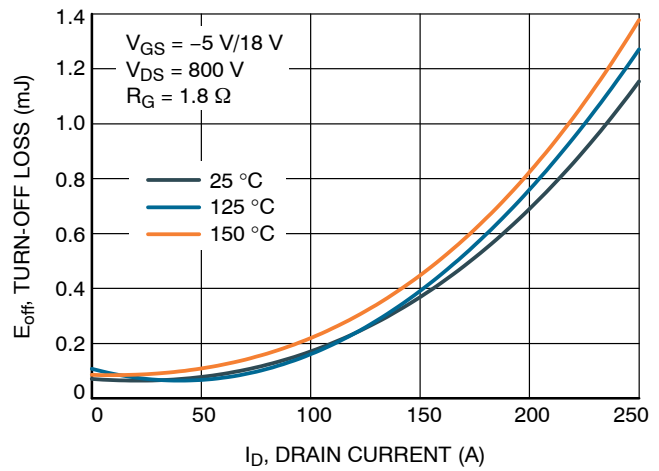

**Figure 13. Typical Switching Loss E<sub>off</sub> vs. Drain Current**

# NXH006P120M3F1PG

## TYPICAL CHARACTERISTICS

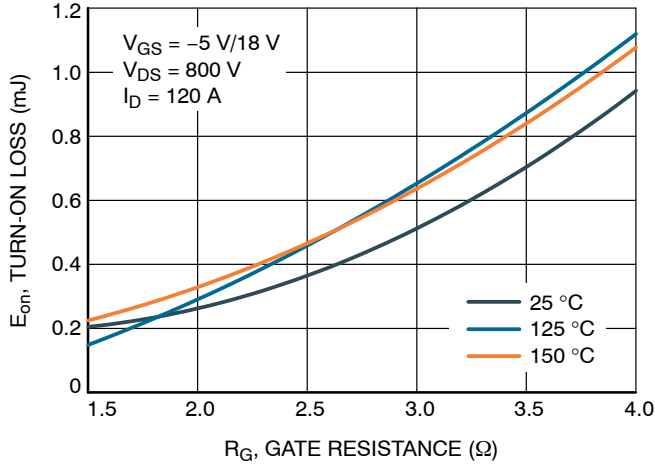

Figure 14. Typical Switching Loss  $E_{on}$  vs.  $R_g$

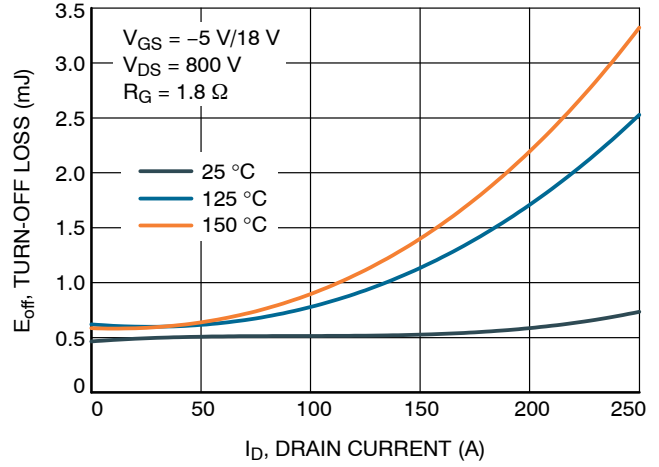

Figure 15. Err vs. Drain Current

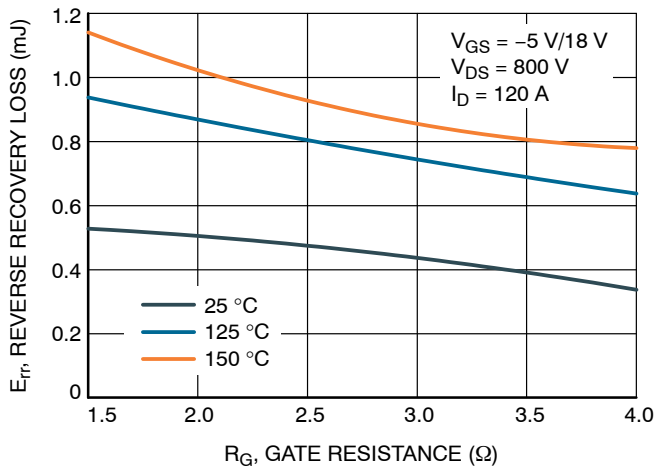

Figure 16. Err vs.  $R_g$

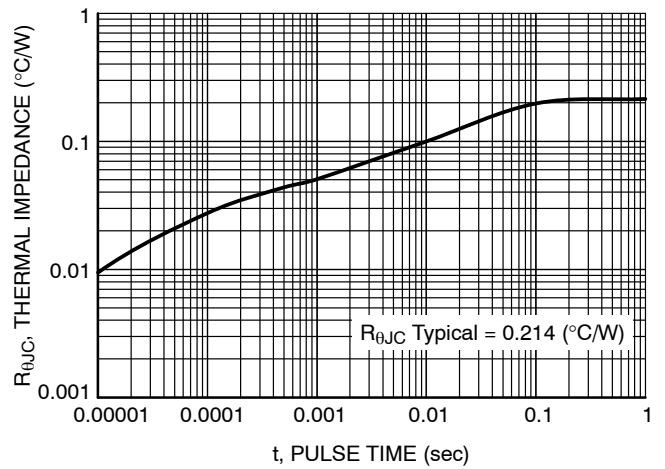

Figure 17. Thermal Response Characteristics

# NXH006P120M3F1PG

## REVISION HISTORY

Revision	Description of Changes	Date
0	Initial document release.	5/18/2026

# NXH006P120M3F1PG

## PACKAGE DIMENSIONS

PIM18 33.8x42.5 (PRESS FIT)  
CASE 180BW  
ISSUE B

DATE 30 APR 2021

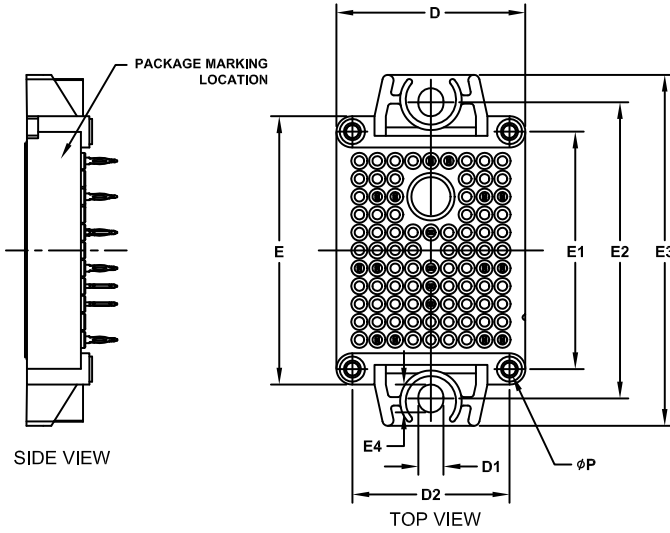
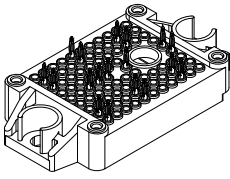

**NOTES:**

1. CONTROLLING DIMENSION: MILLIMETERS
2. PIN POSITION TOLERANCE IS  $\pm 0.4\text{mm}$

DIM	MILLIMETERS		
	MIN.	NOM.	MAX.
A	11.65	12.00	12.35
A1	16.00	16.50	17.00
A2	0.00	0.35	0.60
A3	12.85	13.35	13.85
b	1.15	1.20	1.25
b1	0.59	0.64	0.69
D	33.50	33.80	34.10
D1	4.40	4.50	4.60
D2	27.95	28.10	28.25
E	47.70	48.00	48.30
E1	42.35	42.50	42.65
E2	52.90	53.00	53.10
E3	62.30	62.80	63.30
E4	4.90	5.00	5.10
P	2.20	2.30	2.40

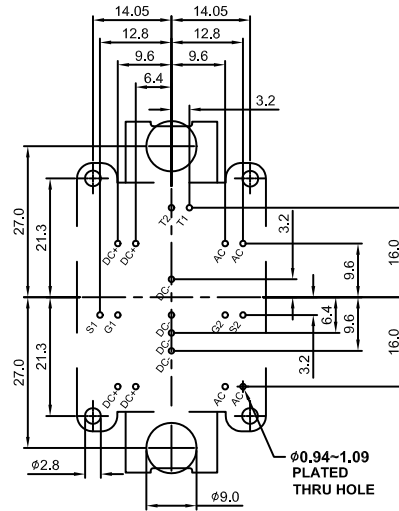
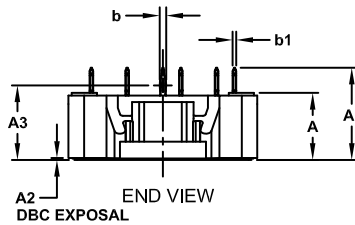

### GENERIC MARKING DIAGRAM\*

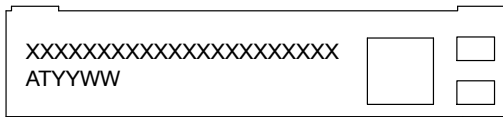

XXXXX = Specific Device Code  
AT = Assembly & Test Site Code  
YYWW = Year and Work Week Code

\*This information is generic. Please refer to device data sheet for actual part marking. Pb-Free indicator, "G" or microdot "▪", may or may not be present. Some products may not follow the Generic Marking.

**onsemi**, **Onsemi**, and other names, marks, and brands are registered and/or common law trademarks of Semiconductor Components Industries, LLC dba "**onsemi**" or its affiliates and/or subsidiaries in the United States and/or other countries. **onsemi** owns the rights to a number of patents, trademarks, copyrights, trade secrets, and other intellectual property. A listing of **onsemi**'s product/patent coverage may be accessed at [www.onsemi.com/site/pdf/Patent-Marking.pdf](http://www.onsemi.com/site/pdf/Patent-Marking.pdf). **onsemi** reserves the right to make changes at any time to any products or information herein, without notice. The information herein is provided "as-is" and **onsemi** makes no warranty, representation or guarantee regarding the accuracy of the information, product features, availability, functionality, or suitability of its products for any particular purpose, nor does **onsemi** assume any liability arising out of the application or use of any product or circuit, and specifically disclaims any and all liability, including without limitation special, consequential or incidental damages. Buyer is responsible for its products and applications using **onsemi** products, including compliance with all laws, regulations and safety requirements or standards, regardless of any support or applications information provided by **onsemi**. "Typical" parameters which may be provided in **onsemi** data sheets and/or specifications can and do vary in different applications and actual performance may vary over time. All operating parameters, including "Typicals" must be validated for each customer application by customer's technical experts. **onsemi** does not convey any license under any of its intellectual property rights nor the rights of others. **onsemi** products are not designed, intended, or authorized for use as a critical component in life support systems or any FDA Class 3 medical devices or medical devices with a same or similar classification in a foreign jurisdiction or any devices intended for implantation in the human body. Should Buyer purchase or use **onsemi** products for any such unintended or unauthorized application, Buyer shall indemnify and hold **onsemi** and its officers, employees, subsidiaries, affiliates, and distributors harmless against all claims, costs, damages, and expenses, and reasonable attorney fees arising out of, directly or indirectly, any claim of personal injury or death associated with such unintended or unauthorized use, even if such claim alleges that **onsemi** was negligent regarding the design or manufacture of the part. **onsemi** is an Equal Opportunity/Affirmative Action Employer. This literature is subject to all applicable copyright laws and is not for resale in any manner.

#### ADDITIONAL INFORMATION

**TECHNICAL PUBLICATIONS:**

Technical Library: [www.onsemi.com/design/resources/technical-documentation](http://www.onsemi.com/design/resources/technical-documentation)  
onsemi Website: [www.onsemi.com](http://www.onsemi.com)

**ONLINE SUPPORT:** [www.onsemi.com/support](http://www.onsemi.com/support)

For additional information, please contact your local Sales Representative at [www.onsemi.com/support/sales](http://www.onsemi.com/support/sales)