

Low-Voltage CMOS Octal Buffer Flow Through Pinout

With 5 V-Tolerant Inputs and Outputs
(3-State, Non-Inverting)

MC74LCX541

The MC74LCX541 is a high performance, non-inverting octal buffer operating from a 1.65 to 5.5 V supply. This device is similar in function to the MC74LCX244, while providing flow through architecture. High impedance TTL compatible inputs significantly reduce current loading to input drivers while TTL compatible outputs offer improved switching noise performance. A V_I specification of 5.5 V allows MC74LCX541 inputs to be safely driven from 5 V devices. The MC74LCX541 is suitable for memory address driving and all TTL level bus oriented transceiver applications.

Current drive capability is 24 mA at the outputs at $V_{CC} = 3$ V. The Output Enable ($\overline{OE1}$, $\overline{OE2}$) inputs, when HIGH, disables the output by placing them in a HIGH Z condition.

Features

- Designed for 1.65 to 5.5 V V_{CC} Operation
- 5 V Tolerant – Interface Capability With 5 V TTL Logic
- Supports Live Insertion and Withdrawal
- I_{OFF} Specification Guarantees High Impedance When $V_{CC} = 0$ V
- LVTTTL Compatible
- LVCMOS Compatible
- 24 mA Balanced Output Sink and Source Capability at 3 V
- Near Zero Static Supply Current in All Three Logic States (10 μ A) Substantially Reduces System Power Requirements
- Latchup Performance Exceeds 100 mA
- ESD Performance:
 - ◆ Human Body Model > 2000 V
- -Q Suffix for Automotive and Other Applications Requiring Unique Site and Control Change Requirements; AEC-Q100 Qualified and PPAP Capable
- These Devices are Pb-Free, Halogen Free/BFR Free and are RoHS Compliant

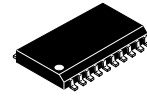

SOIC-20 WB
DW SUFFIX
CASE 751D

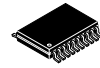

TSSOP-20
DT SUFFIX
CASE 948E

MARKING DIAGRAM

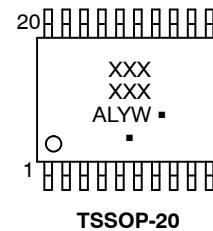
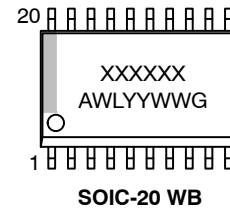

- A = Assembly Location
- L, WL = Wafer Lot
- Y, YY = Year
- W, WW = Work Week
- G or ■ = Pb-Free Package

(Note: Microdot may be in either location)

ORDERING INFORMATION

See detailed ordering and shipping information on page 8 of this data sheet.

MC74LCX541

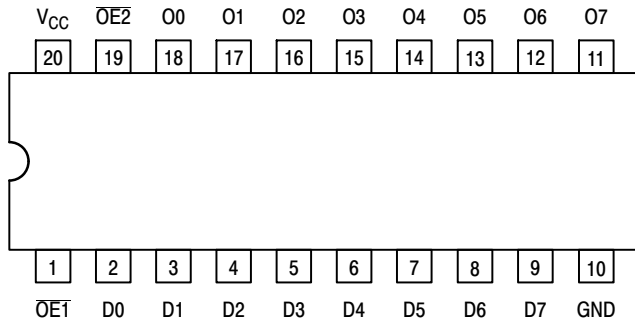

Figure 1. Pinout: 20-Lead (Top View)

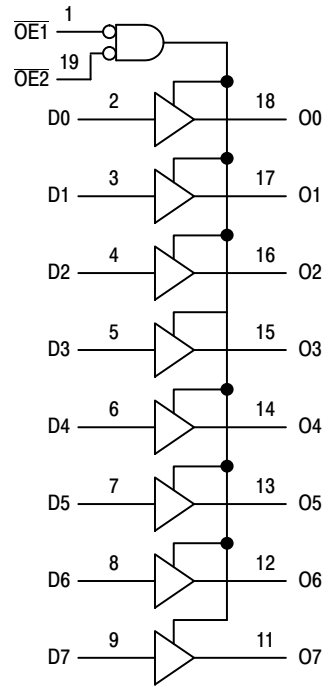

Figure 2. Logic Diagram

PIN NAMES

Pin	Function
\overline{OE}_n	Output Enable Inputs
D_n	Data Inputs
O_n	3-State Outputs

TRUTH TABLE

Inputs			Outputs
\overline{OE}_1	\overline{OE}_2	D_n	O_n
L	L	L	L
L	L	H	H
X	H	X	Z
H	X	X	Z

H = High Voltage Level;
 L = Low Voltage Level;
 Z = High Impedance State;
 X = High or Low Voltage Level and Transitions are Acceptable,
 for I_{CC} reasons, DO NOT FLOAT Inputs

MC74LCX541

MAXIMUM RATINGS

Symbol	Parameter	Value	Unit	
V_{CC}	DC Supply Voltage	-0.5 to +6.5	V	
V_I	DC Input Voltage (Note 1)	-0.5 to +6.5	V	
V_O	DC Output Voltage (Note 1) Active-Mode (High or Low State)	-0.5 to $V_{CC} + 0.5$	V	
	Tri-State Mode	-0.5 to +6.5		
	Power-Down Mode ($V_{CC} = 0$ V)	-0.5 to +6.5		
I_{IK}	DC Input Diode Current $V_{IN} < GND$	-50	mA	
I_{OK}	DC Output Diode Current $V_{OUT} < GND$	-50	mA	
I_O	DC Output Source/Sink Current	± 50	mA	
I_{CC} or I_{GND}	DC Supply Current per Supply Pin or Ground Pin	± 100	mA	
T_{STG}	Storage Temperature Range	-65 to +150	$^{\circ}C$	
T_L	Lead Temperature, 1 mm from Case for 10 secs	260	$^{\circ}C$	
T_J	Junction Temperature Under Bias	+150	$^{\circ}C$	
θ_{JA}	Thermal Resistance (Note 2)	SOIC-20W	96	$^{\circ}C/W$
		WQFN20	99	
		QFN20	111	
		TSSOP-20	150	
P_D	Power Dissipation in Still Air	SOIC-20W	1302	mW
		WQFN20	1256	
		QFN20	1127	
		TSSOP-20	833	
MSL	Moisture Sensitivity	SOIC-20W	Level 3	-
		All Other Packages	Level 1	
F_R	Flammability Rating	Oxygen Index: 28 to 34	UL 94 V-0 @ 0.125 in	-
V_{ESD}	ESD Withstand Voltage (Note 3)	Human Body Model	> 2000	V
		Charged Device Model	N/A	

Stresses exceeding those listed in the Maximum Ratings table may damage the device. If any of these limits are exceeded, device functionality should not be assumed, damage may occur and reliability may be affected.

- I_O absolute maximum rating must be observed.
- Measured with minimum pad spacing on an FR4 board, using 76 mm-by-114 mm, 2-ounce copper trace no air flow per JESD51-7.
- HBM tested to EIA / JESD22-A114-A. CDM tested to JESD22-C101-A. JEDEC recommends that ESD qualification to EIA/JESD22-A115A (Machine Model) be discontinued.

MC74LCX541

RECOMMENDED OPERATING CONDITIONS

Symbol	Parameter	Min	Typ	Max	Unit	
V _{CC}	Supply Voltage	Operating	1.65	3.3	5.5	V
		Data Retention Only	1.5	3.3	5.5	
V _I	Digital Input Voltage	0	–	5.5	V	
V _O	Output Voltage	Active Mode (High or Low State)	0	–	V _{CC}	V
		Tri-State Mode	0	–	5.5	
		Power Down Mode (V _{CC} = 0 V)	0	–	5.5	
T _A	Operating Free-Air Temperature	–40	–	+125	°C	
t _r , t _f	Input Rise or Fall Rate	V _{CC} = 1.65 V to 1.95 V	0	–	20	nS/V
		V _{CC} = 2.3 V to 2.7 V	0	–	20	
		V _I from 0.8 V to 2.0 V, V _{CC} = 3.0 V	0	–	10	
		V _{CC} = 4.5 V to 5.5 V	0	–	5	

Functional operation above the stresses listed in the Recommended Operating Ranges is not implied. Extended exposure to stresses beyond the Recommended Operating Ranges limits may affect device reliability.

4. Unused inputs must always be tied to an appropriate logic voltage level (e.g., either GND or V_{CC}). Unused outputs must be left open.

DC ELECTRICAL CHARACTERISTICS

Symbol	Parameter	Conditions	V _{CC} (V)	T _A = –40 °C to +85 °C		T _A = –40 °C to +125 °C		Unit
				Min	Max	Min	Max	
V _{IH}	High-Level Input Voltage		1.65 to 1.95	0.65 x V _{CC}		0.65 x V _{CC}		V
			2.3 to 2.7	1.7		1.7		
			2.7 to 3.6	2.0		2.0		
			4.5 to 5.5	0.7 x V _{CC}		0.7 x V _{CC}		
V _{IL}	Low-Level Input Voltage		1.65 to 1.95		0.35 x V _{CC}		0.35 x V _{CC}	V
			2.3 to 2.7		0.7		0.7	
			2.7 to 3.6		0.8		0.8	
			4.5 to 5.5		0.3 x V _{CC}		0.3 x V _{CC}	
V _{OH}	High-Level Output Voltage	V _I = V _{IH} or V _{IL}						V
		I _{OH} = –100 μA	1.65 to 5.5	V _{CC} – 0.1	–	V _{CC} – 0.1	–	
		I _{OH} = –4 mA	1.65	1.2	–	1.2	–	
		I _{OH} = –8 mA	2.3	1.8	–	1.8	–	
		I _{OH} = –12 mA	2.7	2.2	–	2.2	–	
		I _{OH} = –16 mA	3.0	2.4	–	2.4	–	
		I _{OH} = –24 mA	3.0	2.2	–	2.2	–	
I _{OH} = –32 mA	4.5	3.8		3.8				
V _{OL}	Low-Level Output Voltage	V _I = V _{IH} or V _{IL}						V
		I _{OL} = 100 μA	1.65 to 5.5	–	0.1	–	0.1	
		I _{OL} = 4 mA	1.65	–	0.45	–	0.45	
		I _{OL} = 8 mA	2.3	–	0.6	–	0.6	
		I _{OL} = 12 mA	2.7	–	0.4	–	0.4	
		I _{OL} = 16 mA	3.0	–	0.4	–	0.4	
		I _{OL} = 24 mA	3.0	–	0.55	–	0.55	
I _{OL} = 32 mA	4.5	–	0.6	–	0.6			
I _I	Input Leakage Current	V _I = 0 to 5.5 V	3.6	–	±5.0	–	±5.0	μA

MC74LCX541

DC ELECTRICAL CHARACTERISTICS

Symbol	Parameter	Conditions	V _{CC} (V)	T _A = -40 °C to +85 °C		T _A = -40 °C to +125 °C		Unit
				Min	Max	Min	Max	
I _{OZ}	3-State Output Leakage Current	V _I = V _{IH} or V _{IL} , V _O = 0 V to 5.5 V	3.6	-	±5.0	-	±5.0	μA
I _{OFF}	Power Off Leakage Current	V _I = 5.5 V or V _O = 5.5 V	0	-	10	-	10	μA
I _{CC}	Quiescent Supply Current	V _I = 5.5 V or GND	3.6	-	10	-	10	μA
ΔI _{CC}	Increase in I _{CC} per Input	V _{IH} = V _{CC} - 0.6 V	2.3 to 3.6	-	500	-	500	μA

Product parametric performance is indicated in the Electrical Characteristics for the listed test conditions, unless otherwise noted. Product performance may not be indicated by the Electrical Characteristics if operated under different conditions.

5. These values of V_I are used to test DC electrical characteristics only.

AC ELECTRICAL CHARACTERISTICS

Symbol	Parameter	Test Condition	V _{CC} (V)	T _A = -40 °C to +85 °C		T _A = -40 °C to +125 °C		Unit
				Min	Max	Min	Max	
t _{PLH} , t _{PHL}	Propagation Delay, D to O	See Figures 3 and 4	1.65 to 1.95	-	10.3	-	10.3	ns
			2.3 to 2.7	-	7.8	-	7.8	
			2.7	-	7.5	-	7.5	
			3.0 to 3.6	-	6.5	-	6.5	
			4.5 to 5.5	-	5.9	-	5.9	
t _{PZH} , t _{PZL}	Output Enable Time, OE to OE to O	See Figures 3 and 4	1.65 to 1.95	-	13.0	-	13.0	ns
			2.3 to 2.7	-	10.5	-	10.5	
			2.7	-	9.5	-	9.5	
			3.0 to 3.6	-	8.5	-	8.5	
			4.5 to 5.5	-	7.3	-	7.3	
t _{PHZ} , t _{PLZ}	Output Disable Time, OE to O	See Figures 3 and 4	1.65 to 1.95	-	11.0	-	11.0	ns
			2.3 to 2.7	-	9.0	-	9.0	
			2.7	-	8.5	-	8.5	
			3.0 to 3.6	-	7.5	-	7.5	
			4.5 to 5.5	-	6.5	-	6.5	
t _{OSSL} , t _{OSLH}	Output to Output Skew (Note 5)		1.65 to 1.95	-	-	-	-	ns
			2.3 to 2.7	-	-	-	-	
			2.7	-	-	-	-	
			3.0 to 3.6	-	1.0	-	1.0	

6. Skew is defined as the absolute value of the difference between the actual propagation delay for any two separate outputs of the same device. The specification applies to any outputs switching in the same direction, either HIGH-to-LOW (t_{OSSL}) or LOW-to-HIGH (t_{OSLH}); parameter guaranteed by design.

MC74LCX541

DYNAMIC SWITCHING CHARACTERISTICS

Symbol	Characteristic	Condition	T _A = +25 °C			Unit
			Min	Typ	Max	
V _{OLP}	Dynamic LOW Peak Voltage (Note 7)	V _{CC} = 3.3 V, C _L = 50 pF, V _{IH} = 3.3 V, V _{IL} = 0 V		0.8		V
V _{OLV}	Dynamic LOW Valley Voltage (Note 7)	V _{CC} = 3.3 V, C _L = 50 pF, V _{IH} = 3.3 V, V _{IL} = 0 V		0.8		V

7. Number of outputs defined as "n". Measured with "n-1" outputs switching from HIGH-to-LOW or LOW-to-HIGH. The remaining output is measured in the LOW state.

CAPACITIVE CHARACTERISTICS

Symbol	Parameter	Condition	Typ	Unit
C _{IN}	Input Capacitance	V _{CC} = 3.3 V, V _I = 0 V or V _{CC}	7	pF
C _{OUT}	Output Capacitance	V _{CC} = 3.3 V, V _I = 0 V or V _{CC}	8	pF
C _{PD}	Power Dissipation Capacitance	10 MHz, V _{CC} = 3.3 V, V _I = 0 V or V _{CC}	25	pF

MC74LCX541

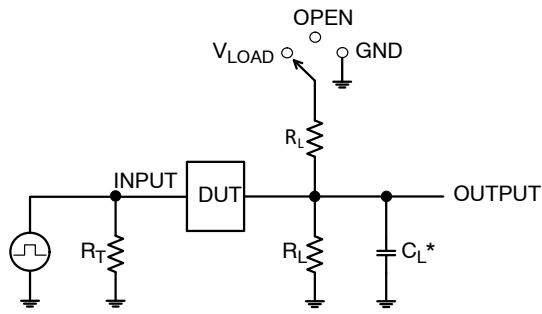

C_L includes probe and jig capacitance
 R_T is Z_{OUT} of pulse generator (typically 50 Ω)
 $f = 1$ MHz

Test	Switch Position
t_{PLH} / t_{PHL}	Open
t_{PLZ} / t_{PZL}	V_{LOAD}
t_{PHZ} / t_{PZH}	GND

Figure 3. Test Circuit

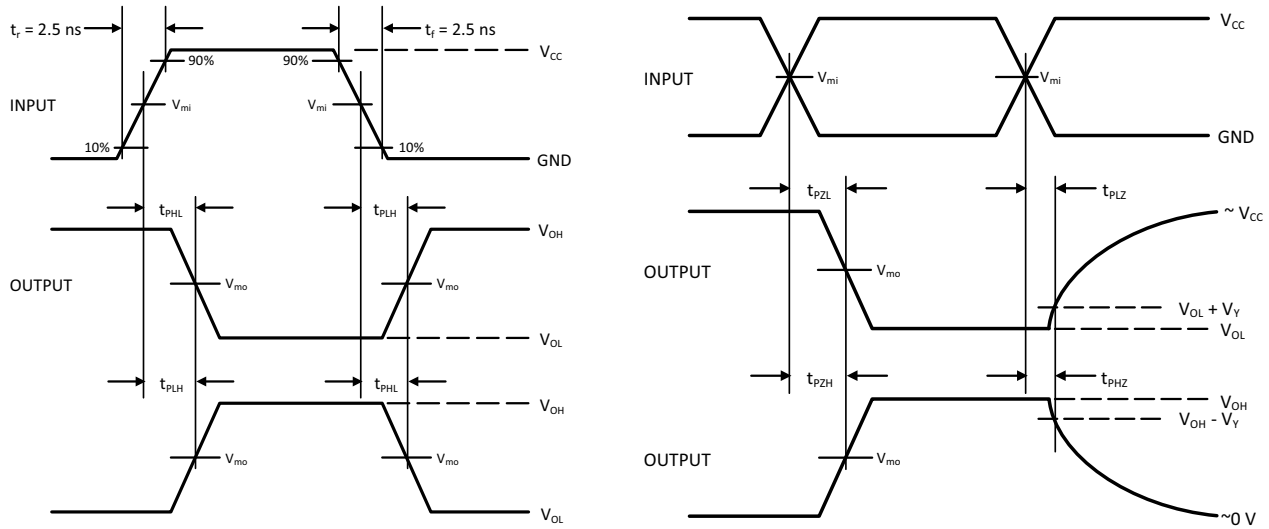

V_{CC}, V	R_L, Ω	C_L, pF	V_{LOAD}	V_{mi}, V	V_{mo}, V	V_Y, V
1.65 to 1.95	500	30	$2 \times V_{CC}$	$V_{CC}/2$	$V_{CC}/2$	0.15
2.3 to 2.7	500	30	$2 \times V_{CC}$	$V_{CC}/2$	$V_{CC}/2$	0.15
2.7	500	50	6 V	1.5	$V_{CC}/2$	0.3
3.0 to 3.6	500	50	6 V	1.5	$V_{CC}/2$	0.3
4.5 to 4.5	500	50	$2 \times V_{CC}$	$V_{CC}/2$	$V_{CC}/2$	0.3

Figure 4. Switching Waveforms

MC74LCX541

ORDERING INFORMATION

Device	Marking	Package	Shipping†
MC74LCX541DWR2G	LCX541	SOIC-20 (Pb-Free)	1000 / Tape & Reel
MC74LCX541DWG	LCX541	SOIC-20 (Pb-Free)	38 Units / Rail
MC74LCX541DTG	LCX 541	TSSOP-20 (Pb-Free)	75 Units / Rail
MC74LCX541DTR2G	LCX 541	TSSOP-20 (Pb-Free)	2500 / Tape & Reel

†For information on tape and reel specifications, including part orientation and tape sizes, please refer to our Tape and Reel Packaging Specifications Brochure, [BRD8011/D](#).

*-Q Suffix for Automotive and Other Applications Requiring Unique Site and Control Change Requirements; AEC-Q100 Qualified and PPAP Capable.

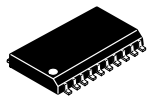

SCALE 1:1

SOIC-20 WB
CASE 751D-05
ISSUE H

DATE 22 APR 2015

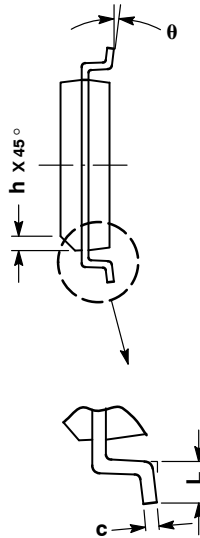
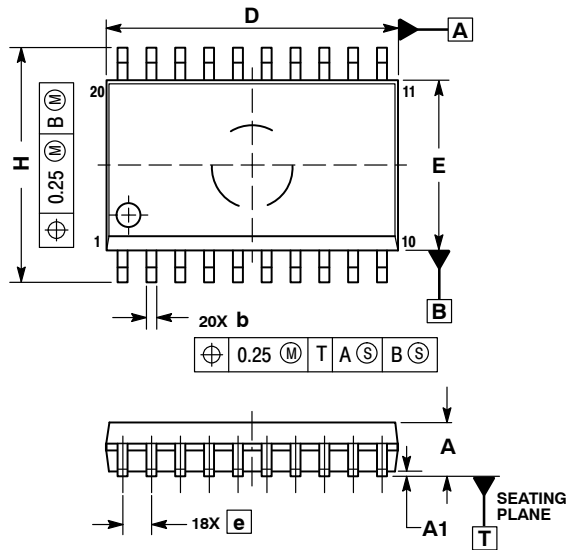

NOTES:

1. DIMENSIONS ARE IN MILLIMETERS.
2. INTERPRET DIMENSIONS AND TOLERANCES PER ASME Y14.5M, 1994.
3. DIMENSIONS D AND E DO NOT INCLUDE MOLD PROTRUSION.
4. MAXIMUM MOLD PROTRUSION 0.15 PER SIDE.
5. DIMENSION B DOES NOT INCLUDE DAMBAR PROTRUSION. ALLOWABLE PROTRUSION SHALL BE 0.13 TOTAL IN EXCESS OF B DIMENSION AT MAXIMUM MATERIAL CONDITION.

DIM	MILLIMETERS	
	MIN	MAX
A	2.35	2.65
A1	0.10	0.25
b	0.35	0.49
c	0.23	0.32
D	12.65	12.95
E	7.40	7.60
e	1.27 BSC	
H	10.05	10.55
h	0.25	0.75
L	0.50	0.90
θ	0°	7°

RECOMMENDED
SOLDERING FOOTPRINT*

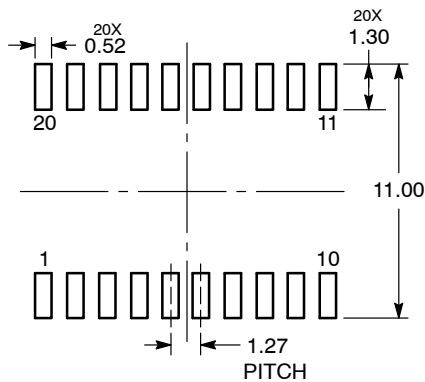

DIMENSIONS: MILLIMETERS

*For additional information on our Pb-Free strategy and soldering details, please download the onsemi Soldering and Mounting Techniques Reference Manual, SOLDERRM/D.

GENERIC
MARKING DIAGRAM*

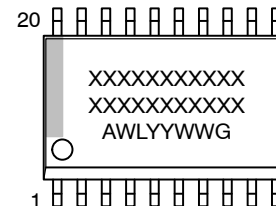

- XXXXXX = Specific Device Code
- A = Assembly Location
- WL = Wafer Lot
- YY = Year
- WW = Work Week
- G = Pb-Free Package

*This information is generic. Please refer to device data sheet for actual part marking. Pb-Free indicator, "G" or microdot "▪", may or may not be present. Some products may not follow the Generic Marking.

DOCUMENT NUMBER:	98ASB42343B	Electronic versions are uncontrolled except when accessed directly from the Document Repository. Printed versions are uncontrolled except when stamped "CONTROLLED COPY" in red.
DESCRIPTION:	SOIC-20 WB	PAGE 1 OF 1

onsemi and onsemi are trademarks of Semiconductor Components Industries, LLC dba onsemi or its subsidiaries in the United States and/or other countries. onsemi reserves the right to make changes without further notice to any products herein. onsemi makes no warranty, representation or guarantee regarding the suitability of its products for any particular purpose, nor does onsemi assume any liability arising out of the application or use of any product or circuit, and specifically disclaims any and all liability, including without limitation special, consequential or incidental damages. onsemi does not convey any license under its patent rights nor the rights of others.

onsemi, **Onsemi**, and other names, marks, and brands are registered and/or common law trademarks of Semiconductor Components Industries, LLC dba "**onsemi**" or its affiliates and/or subsidiaries in the United States and/or other countries. **onsemi** owns the rights to a number of patents, trademarks, copyrights, trade secrets, and other intellectual property. A listing of **onsemi**'s product/patent coverage may be accessed at www.onsemi.com/site/pdf/Patent-Marking.pdf. **onsemi** reserves the right to make changes at any time to any products or information herein, without notice. The information herein is provided "as-is" and **onsemi** makes no warranty, representation or guarantee regarding the accuracy of the information, product features, availability, functionality, or suitability of its products for any particular purpose, nor does **onsemi** assume any liability arising out of the application or use of any product or circuit, and specifically disclaims any and all liability, including without limitation special, consequential or incidental damages. Buyer is responsible for its products and applications using **onsemi** products, including compliance with all laws, regulations and safety requirements or standards, regardless of any support or applications information provided by **onsemi**. "Typical" parameters which may be provided in **onsemi** data sheets and/or specifications can and do vary in different applications and actual performance may vary over time. All operating parameters, including "Typicals" must be validated for each customer application by customer's technical experts. **onsemi** does not convey any license under any of its intellectual property rights nor the rights of others. **onsemi** products are not designed, intended, or authorized for use as a critical component in life support systems or any FDA Class 3 medical devices or medical devices with a same or similar classification in a foreign jurisdiction or any devices intended for implantation in the human body. Should Buyer purchase or use **onsemi** products for any such unintended or unauthorized application, Buyer shall indemnify and hold **onsemi** and its officers, employees, subsidiaries, affiliates, and distributors harmless against all claims, costs, damages, and expenses, and reasonable attorney fees arising out of, directly or indirectly, any claim of personal injury or death associated with such unintended or unauthorized use, even if such claim alleges that **onsemi** was negligent regarding the design or manufacture of the part. **onsemi** is an Equal Opportunity/Affirmative Action Employer. This literature is subject to all applicable copyright laws and is not for resale in any manner.

ADDITIONAL INFORMATION

TECHNICAL PUBLICATIONS:

Technical Library: www.onsemi.com/design/resources/technical-documentation
onsemi Website: www.onsemi.com

ONLINE SUPPORT: www.onsemi.com/support

For additional information, please contact your local Sales Representative at www.onsemi.com/support/sales

