

# CS4192

## Single Air-Core Gauge Driver

The CS4192 is a monolithic BiCMOS integrated circuit used to translate a digital 10-bit word from a microprocessor/microcontroller to complementary DC outputs. The DC outputs drive an air-core meter commonly used in vehicle instrument panels. The 10 bits of data are used to linearly control the quadrature coils of the meter directly with a 0.35° resolution and ±1.2° accuracy over the full 360° range of the gauge. The interface from the microcontroller is by a Serial Peripheral Interface (SPI) compatible serial connection using up to a 2.0 MHz shift clock rate.

The digital code, which is directly proportional to the desired gauge pointer deflection, is shifted into a DAC and multiplexer. These two blocks provide a tangential conversion function to change the digital data into the appropriate DC coil voltage for the angle demanded. The tangential algorithm creates approximately 40% more torque in the meter movement than does a sin-cos algorithm at 45°, 135°, 225°, and 315° angles. This increased torque reduces the error due to pointer droop at these critical angles.

Each output buffer is capable of supplying up to 70 mA per coil and the buffers are controlled by a common OE enable pin. The output buffers are turned off when OE is brought low, while the logic portion of the chip remains powered and continues to operate normally. OE must be high before the falling edge of CS to enable the output buffers. The status pin (ST) reflects the state of the outputs and is low whenever the outputs are disabled.

The Serial Gauge Driver is self-protected against fault conditions. Each driver is protected for 125 mA (typ) overcurrent while a global thermal protection circuit limits junction temperature to 170°C (typ). The output drivers are disabled anytime the IC protection circuitry detects an overcurrent or overtemperature fault. The drivers remain disabled until a falling edge is presented on CS. If the fault is still present, the output drivers automatically disable themselves again.

### Features

- Serial Input Bus
- 2.0 MHz Operating Frequency
- Tangential Drive Algorithm
- 70 mA Drive Circuits
- 0.5° Accuracy (Typ)
- Power-On-Reset
- Protection Features
  - ◆ Output Short Circuit
  - ◆ Overtemperature
- Internally Fused Leads in SOIC-16 WB Package
- Pb-Free Packages are Available\*

\*For additional information on our Pb-Free strategy and soldering details, please download the ON Semiconductor Soldering and Mounting Techniques Reference Manual, SOLDERRM/D.



ON Semiconductor®

<http://onsemi.com>

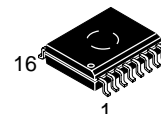

SOIC-16 WB  
DWF SUFFIX  
CASE 751G

### MARKING DIAGRAM

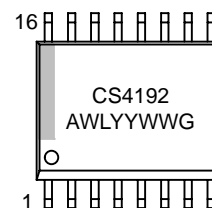

CS4192 = Specific Device Code  
A = Assembly Location  
WL = Wafer Lot  
YY = Year  
WW = Work Week  
G = Pb-Free Package

### PIN CONNECTIONS

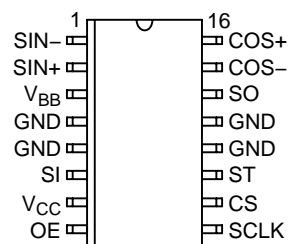

### ORDERING INFORMATION

See detailed ordering and shipping information in the package dimensions section on page 4 of this data sheet.

# CS4192

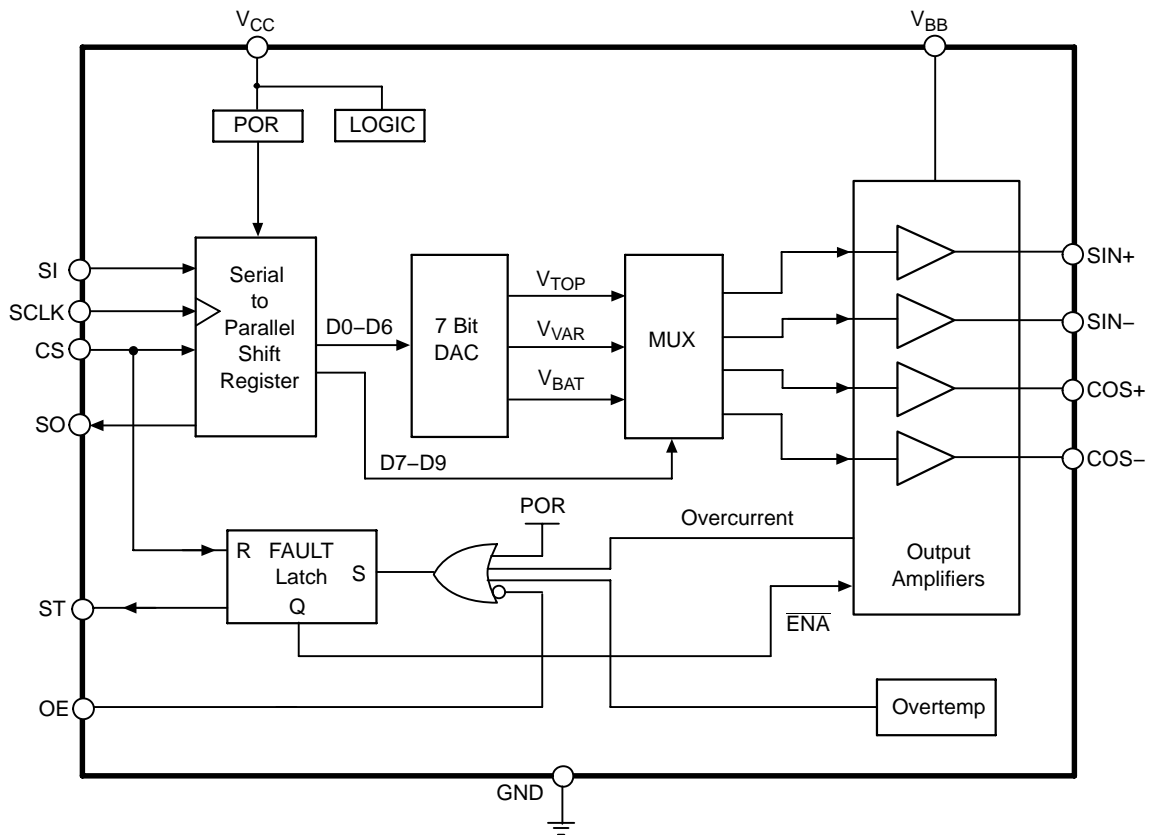

Figure 1. Block Diagram

## MAXIMUM RATINGS

Rating	Value	Unit	
Supply Voltage	$V_{BB}$ -1.0 to 16.5 $V_{CC}$ -1.0 to 6.0	V	
Digital Inputs	-1.0 to 6.0	V	
Steady State Output Current	±100	mA	
Forced Injection Current (Inputs and Supply)	±10	mA	
Operating Junction Temperature, ( $T_J$ )	150	°C	
Storage Temperature Range	-65 to 150	°C	
Lead Temperature Soldering	Reflow (SMD styles only) (Note 1)	230 peak	°C
ESD Susceptibility (Human Body Model)	2.0	kV	
Package Thermal Resistance, SOIC-16 WB			
Junction-to-Case, $R_{\theta JC}$	18	°C/W	
Junction-to-Ambient, $R_{\theta JA}$	75	°C/W	

Maximum ratings are those values beyond which device damage can occur. Maximum ratings applied to the device are individual stress limit values (not normal operating conditions) and are not valid simultaneously. If these limits are exceeded, device functional operation is not implied, damage may occur and reliability may be affected.

1. 60 seconds max above 183°.

# CS4192

## ELECTRICAL CHARACTERISTICS ( $-40^{\circ}\text{C} \leq T_J \leq 105^{\circ}\text{C}$ ; $7.5\text{ V} \leq V_{\text{BB}} \leq 14\text{ V}$ , $4.5\text{ V} \leq V_{\text{CC}} \leq 5.5\text{ V}$ ; unless otherwise specified. Note 2)

Characteristic	Test Conditions	Min	Typ	Max	Unit
----------------	-----------------	-----	-----	-----	------

### Supply Voltages and Currents

$V_{\text{BB}}$ Quiescent Current	Output disabled ( $\text{OE} = 0\text{ V}$ )	–	1.0	5.0	mA
	[ $R_{\text{COS}}$ , $R_{\text{SIN}} = R_{\text{L(MIN)}}$ ] @ $45^{\circ}$ (code = X'080) $V_{\text{BB}} = 14\text{ V}$	–	–	175	mA
$V_{\text{CC}}$ Quiescent Current	OE, CS, DI = high, $V_{\text{BB}} = 0\text{ V}$ , SCLK = 2.0 MHz	–	–	1.15	mA

### Digital Inputs and Outputs

Output High Voltage	SO, $I_{\text{OH}} = 0.8\text{ mA}$	$V_{\text{CC}} - 0.8$	–	–	V
Output Low Voltage	SO, $I_{\text{OL}} = 0.8\text{ mA}$	–	–	0.4	V
	ST, $I_{\text{OL}} = 2.5\text{ mA}$	–	–	0.8	V
Output Off Leakage	ST, $V_{\text{CC}} = 5.0\text{ V}$	–	–	25	$\mu\text{A}$
Input High Voltage	CS, SCLK, SI, OE	$0.7 \times V_{\text{CC}}$	–	–	V
Input Low Voltage	CS, SCLK, SI, OE	–	–	$0.3 \times V_{\text{CC}}$	V
Input High Current	CS, SCLK, SI, OE; $V_{\text{IN}} = 0.7 \times V_{\text{CC}}$	–	–	1.0	$\mu\text{A}$
Input Low Current	CS, SCLK, SI, OE; $V_{\text{IN}} = 0.3 \times V_{\text{CC}}$	–	–	1.0	$\mu\text{A}$

### Analog Outputs

Output Function Accuracy	–	–1.2	$\pm 0.5$	+1.2	deg
Output Shutdown Current, Source	$V_{\text{BB}} = 14\text{ V}$	70	125	250	mA
Output Shutdown Current, Sink	$V_{\text{BB}} = 14\text{ V}$	70	125	250	mA
Output Shutdown Current, Source	$V_{\text{BB}} = 7.5\text{ V}$	43	125	250	mA
Output Shutdown Current, Sink	$V_{\text{BB}} = 7.5\text{ V}$	43	125	250	mA
Thermal Shutdown	–	–	170	–	$^{\circ}\text{C}$
Thermal Shutdown Hysteresis	–	–	20	–	$^{\circ}\text{C}$
Coil Drive Output Voltage	–	–	$0.748 \times V_{\text{BB}}$	–	V
Minimum Load Resistance	$T_A = 105^{\circ}\text{C}$	–	229	–	$\Omega$
	$T_A = 25^{\circ}\text{C}$	–	171	–	$\Omega$
	$T_A = -40^{\circ}\text{C}$	–	150	–	$\Omega$
Shift Clock Frequency	–	–	–	2.0	MHz
SCLK High Time	–	175	–	–	ns
SCLK Low Time	–	175	–	–	ns
SO Rise Time	0.75 V to $V_{\text{CC}} - 1.2\text{ V}$ ; $C_L = 90\text{ pF}$	–	–	150	ns
SO Fall Time	0.75 V to $V_{\text{CC}} - 1.2\text{ V}$ ; $C_L = 90\text{ pF}$	–	–	150	ns
SO Delay Time	$C_L = 90\text{ pF}$	–	–	150	ns
SI Setup Time	–	75	–	–	ns
SI Hold Time	–	75	–	–	ns
CS Setup Time	Note 3.	0	–	–	ns
CS Hold Time	–	75	–	–	ns

2. Designed to meet these characteristics over the stated voltage and temperature ranges, though may not be 100% parametrically tested in production.

3. OE must be high at falling edge of CS. This condition ensures valid output for any given input.

# CS4192

## PIN FUNCTION DESCRIPTION

PACKAGE PIN # 16 Lead SOIC Wide	PIN SYMBOL	FUNCTION
1	SIN-	Negative output for SINE coil.
2	SIN+	Positive output SINE coil.
3	V <sub>BB</sub>	Analog supply. Nominally 13.5 V.
4, 5, 12, 13	GND	Ground.
6	SI	Serial data input. Data present at the rising edge of the clock signal is shifted into the internal shift register.
7	V <sub>CC</sub>	5.0 V logic supply. The internal registers and latches are reset by a POR generated by the rising edge of the voltage on this pin.
8	OE	Controls the state of the output buffers. A logic low on this pin turns them off.
9	SCLK	Serial clock for shifting in/out of data. Rising edge shifts data on SI into the shift register and the falling edge changes the data on SO.
10	CS	When high allows data at SI to be shifted into part with the rising edges of SCLK. The falling edge transfers the shift register contents into the DAC and multiplexer to update the output buffers. The falling edge also reenables the output drivers if they have been disabled by a fault.
11	ST	STATUS reflects the state of the outputs and is low anytime the outputs are disabled, either by OE or the internal protection circuitry. Requires external pullup resistor.
14	SO	Serial data output. Existing 10-bit data is shifted out when new data is shifted in. Allows cascading of multiple devices on common serial port.
15	COS-	Negative output for COSINE coil.
16	COS+	Positive output for COSINE coil.

## ORDERING INFORMATION

Device	Package	Shipping <sup>†</sup>
CS4192XDWF16	SOIC-16 WB	47 Units / Rail
CS4192XDWF16G	SOIC-16 WB (Pb-Free)	47 Units / Rail
CS4192XDWFR16	SOIC-16 WB	1000 Units / Reel
CS4192XDWFR16G	SOIC-16 WB (Pb-Free)	1000 Units / Reel

<sup>†</sup>For information on tape and reel specifications, including part orientation and tape sizes, please refer to our Tape and Reel Packaging Specifications Brochure, BRD8011/D.

APPLICATIONS INFORMATION

THEORY OF OPERATION

The SACD is for interfacing between a microcontroller or microprocessor and air-core meter movements commonly used in automotive vehicles for speedometers and tachometers. These movements are built using two coils placed at a 90° orientation to each other. A magnetized disc floats in the middle of the coils and responds to the magnetic field generated by each coil. The disc has a shaft attached to it that protrudes out of the assembly. A pointer indicator is attached to this shaft and in conjunction with a separate printed scale displays the vehicle's speed or the engine's speed.

The disc (and pointer) respond to the vector sum of the voltages applied to the coils. Ideally, this relationship follows a sine/cosine equation. Since this is a transcendental and non-linear function, devices of this type use an approximation for this relationship. The SACD uses a tangential algorithm as shown in Figure 2. Only one output varies in any 45 degree range.

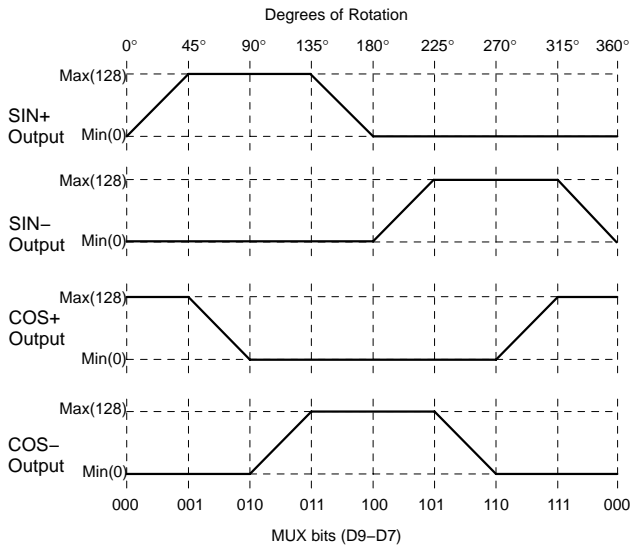

Figure 2. SIN, COS Outputs

Quadrant I

$$\theta = \text{Tan}^{-1} \left[ \frac{V_{\text{SIN}+} - V_{\text{SIN}-}}{V_{\text{COS}+} - V_{\text{COS}-}} \right]$$

For  $\theta = 0.176^\circ$  to  $44.824^\circ$  :

$$V_{\text{SIN}} = \text{Tan}\theta \times 0.748 \times V_{\text{BB}}$$

$$V_{\text{COS}} = 0.748 \times V_{\text{BB}}$$

For  $\theta = 45.176^\circ$  to  $89.824^\circ$  :

$$V_{\text{SIN}} = 0.748 \times V_{\text{BB}}$$

$$V_{\text{COS}} = \text{Tan}(90^\circ - \theta) \times 0.748 \times V_{\text{BB}}$$

Quadrant II

$$\theta = 180^\circ - \text{Tan}^{-1} \left[ \frac{V_{\text{SIN}+} - V_{\text{SIN}-}}{V_{\text{COS}+} - V_{\text{COS}-}} \right]$$

For  $\theta = 90.176^\circ$  to  $134.824^\circ$  :

$$V_{\text{SIN}} = 0.748 \times V_{\text{BB}}$$

$$V_{\text{COS}} = -\text{Tan}(\theta - 90^\circ) \times 0.748 \times V_{\text{BB}}$$

For  $\theta = 135.176^\circ$  to  $179.824^\circ$  :

$$V_{\text{SIN}} = \text{Tan}(180^\circ - \theta) \times 0.748 \times V_{\text{BB}}$$

$$V_{\text{COS}} = -0.748 \times V_{\text{BB}}$$

Quadrant III

$$\theta = 180^\circ + \text{Tan}^{-1} \left[ \frac{V_{\text{SIN}+} - V_{\text{SIN}-}}{V_{\text{COS}+} - V_{\text{COS}-}} \right]$$

For  $\theta = 180.176^\circ$  to  $224.824^\circ$  :

$$V_{\text{SIN}} = -\text{Tan}(\theta - 180^\circ) \times 0.748 \times V_{\text{BB}}$$

$$V_{\text{COS}} = -0.748 \times V_{\text{BB}}$$

For  $\theta = 225.176^\circ$  to  $269.824^\circ$  :

$$V_{\text{SIN}} = -0.748 \times V_{\text{BB}}$$

$$V_{\text{COS}} = -\text{Tan}(270^\circ - \theta) \times 0.748 \times V_{\text{BB}}$$

Quadrant IV

$$\theta = 360^\circ - \text{Tan}^{-1} \left[ \frac{V_{\text{SIN}+} - V_{\text{SIN}-}}{V_{\text{COS}+} - V_{\text{COS}-}} \right]$$

For  $\theta = 270.176^\circ$  to  $314.824^\circ$  :

$$V_{\text{SIN}} = -0.748 \times V_{\text{BB}}$$

$$V_{\text{COS}} = \text{Tan}(\theta - 270^\circ) \times 0.748 \times V_{\text{BB}}$$

For  $\theta = 315.176^\circ$  to  $359.824^\circ$  :

$$V_{\text{SIN}} = -\text{Tan}(360^\circ - \theta) \times 0.748 \times V_{\text{BB}}$$

$$V_{\text{COS}} = 0.748 \times V_{\text{BB}}$$

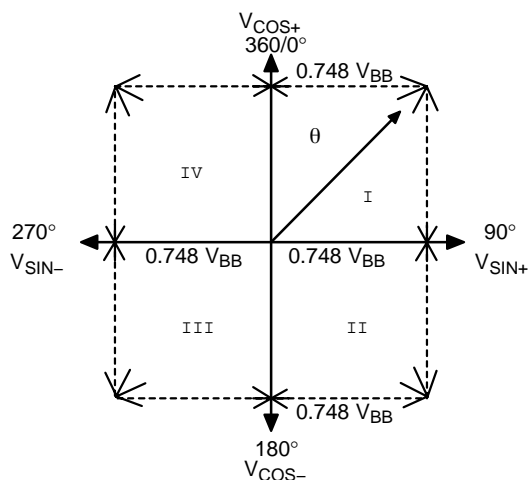

Figure 3. Gauge Response

To drive the gauge’s pointer to a particular angle, the microcontroller sends a 10-bit digital word into the serial port. These 10 bits are divided as shown in Figure 4.

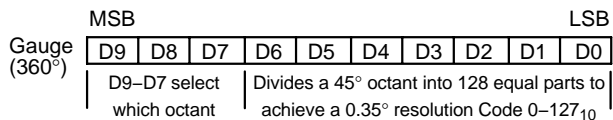

Figure 4. Definition of Serial Word

However, from a software programmers viewpoint, a 360° circle is divided into 1024 equal parts of 0.35° each. Table 1 shows the data associated with the 45° divisions of the 360° driver.

Table1. Nominal Output (V<sub>BB</sub> = 14 V)

Input Code (Decimal)	Ideal Degrees	Nominal Degrees	V <sub>SIN</sub> (V)	V <sub>COS</sub> (V)
0	0	0.176	0.032	10.476
128	45	45.176	10.476	10.412
256	90	90.176	10.476	-0.032
384	135	135.176	10.412	-10.476
512	180	180.176	-0.032	-10.476
640	225	225.176	-10.476	-10.412
768	270	270.176	-10.476	0.032
896	315	315.176	-10.476	10.476
1023	359.65	359.826	-0.032	10.476

The 10 bits are shifted into the device’s shift register MSB first using an SPI compatible scheme. This method is shown in Figure 5. The CS must be high and remain high for SCLK to be enabled. Data on SI is shifted in on the rising edge of the synchronous clock signal. Data in the shift register changes at SO on the falling edge of SCLK. This arrangement allows the cascading of devices. SO is always enabled. Data shifts through without affecting the outputs until CS is brought low. At this time the internal DAC is updated and the outputs change accordingly.

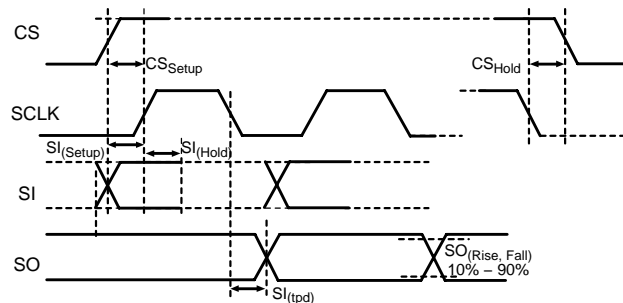

Figure 5. Serial Data Timing Diagram

Figure 6 shows the power-up sequence for the CS4192. Note the IC requires a pulse on the Chip Select (CS) pin to clear the Status Fault (ST) after power up. OE must be high before the falling edge of CS to enable the output buffers.

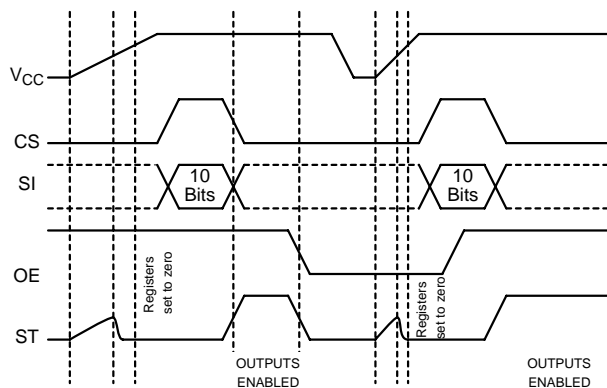

Figure 6. Power Up Sequence

# CS4192

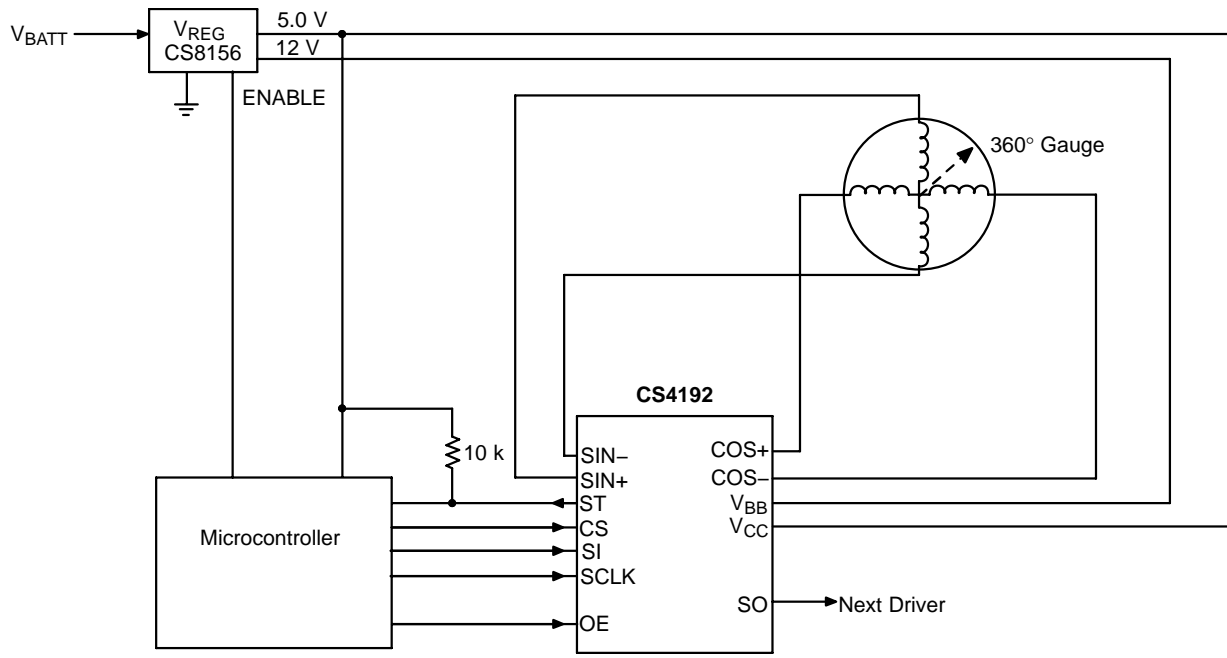
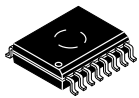

Figure 7. Application Diagram



1  
SCALE 1:1

SOIC-16 WB  
CASE 751G  
ISSUE E

DATE 08 OCT 2021

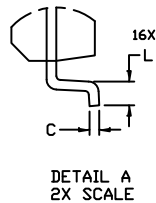
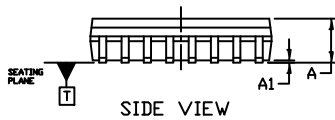
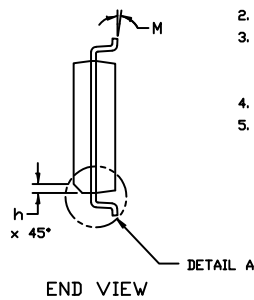
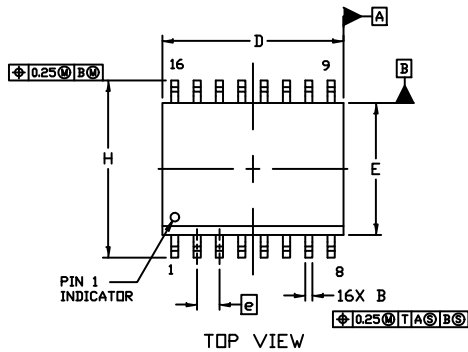

NOTES:

- DIMENSIONING AND TOLERANCING PER ASME Y14.5M, 1994.
- CONTROLLING DIMENSION: MILLIMETERS
- DIMENSION b DOES NOT INCLUDE DAMBAR PROTRUSION. ALLOWABLE PROTRUSION SHALL BE 0.13 TOTAL IN EXCESS OF B DIMENSION AT MAXIMUM MATERIAL CONDITION.
- DIMENSIONS D AND E DO NOT INCLUDE MOLD PROTRUSIONS.
- MAXIMUM MOLD PROTRUSION OR FLASH TO BE 0.15 PER SIDE.

DIM	MILLIMETERS	
	MIN.	MAX.
A	2.35	2.65
A1	0.10	0.25
B	0.35	0.49
C	0.23	0.32
D	10.15	10.45
E	7.40	7.60
e	1.27 BSC	
H	10.05	10.55
h	0.53 REF	
L	0.50	0.90
M	0°	7°

GENERIC  
MARKING DIAGRAM\*

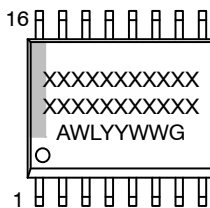

- XXXXXX = Specific Device Code
- A = Assembly Location
- WL = Wafer Lot
- YY = Year
- WW = Work Week
- G = Pb-Free Package

\*This information is generic. Please refer to device data sheet for actual part marking. Pb-Free indicator, "G" or microdot "•", may or may not be present. Some products may not follow the Generic Marking.

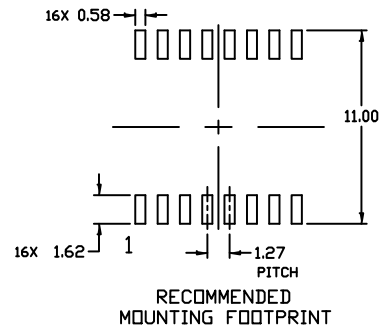

DOCUMENT NUMBER:	98ASB42567B	Electronic versions are uncontrolled except when accessed directly from the Document Repository. Printed versions are uncontrolled except when stamped "CONTROLLED COPY" in red.
DESCRIPTION:	SOIC-16 WB	PAGE 1 OF 1

onsemi and onSEMI are trademarks of Semiconductor Components Industries, LLC dba onsemi or its subsidiaries in the United States and/or other countries. onsemi reserves the right to make changes without further notice to any products herein. onsemi makes no warranty, representation or guarantee regarding the suitability of its products for any particular purpose, nor does onsemi assume any liability arising out of the application or use of any product or circuit, and specifically disclaims any and all liability, including without limitation special, consequential or incidental damages. onsemi does not convey any license under its patent rights nor the rights of others.

**onsemi**, **Onsemi**, and other names, marks, and brands are registered and/or common law trademarks of Semiconductor Components Industries, LLC dba "**onsemi**" or its affiliates and/or subsidiaries in the United States and/or other countries. **onsemi** owns the rights to a number of patents, trademarks, copyrights, trade secrets, and other intellectual property. A listing of **onsemi**'s product/patent coverage may be accessed at [www.onsemi.com/site/pdf/Patent-Marking.pdf](http://www.onsemi.com/site/pdf/Patent-Marking.pdf). **onsemi** reserves the right to make changes at any time to any products or information herein, without notice. The information herein is provided "as-is" and **onsemi** makes no warranty, representation or guarantee regarding the accuracy of the information, product features, availability, functionality, or suitability of its products for any particular purpose, nor does **onsemi** assume any liability arising out of the application or use of any product or circuit, and specifically disclaims any and all liability, including without limitation special, consequential or incidental damages. Buyer is responsible for its products and applications using **onsemi** products, including compliance with all laws, regulations and safety requirements or standards, regardless of any support or applications information provided by **onsemi**. "Typical" parameters which may be provided in **onsemi** data sheets and/or specifications can and do vary in different applications and actual performance may vary over time. All operating parameters, including "Typicals" must be validated for each customer application by customer's technical experts. **onsemi** does not convey any license under any of its intellectual property rights nor the rights of others. **onsemi** products are not designed, intended, or authorized for use as a critical component in life support systems or any FDA Class 3 medical devices or medical devices with a same or similar classification in a foreign jurisdiction or any devices intended for implantation in the human body. Should Buyer purchase or use **onsemi** products for any such unintended or unauthorized application, Buyer shall indemnify and hold **onsemi** and its officers, employees, subsidiaries, affiliates, and distributors harmless against all claims, costs, damages, and expenses, and reasonable attorney fees arising out of, directly or indirectly, any claim of personal injury or death associated with such unintended or unauthorized use, even if such claim alleges that **onsemi** was negligent regarding the design or manufacture of the part. **onsemi** is an Equal Opportunity/Affirmative Action Employer. This literature is subject to all applicable copyright laws and is not for resale in any manner.

## ADDITIONAL INFORMATION

### TECHNICAL PUBLICATIONS:

Technical Library: [www.onsemi.com/design/resources/technical-documentation](http://www.onsemi.com/design/resources/technical-documentation)  
onsemi Website: [www.onsemi.com](http://www.onsemi.com)

### ONLINE SUPPORT: [www.onsemi.com/support](http://www.onsemi.com/support)

For additional information, please contact your local Sales Representative at [www.onsemi.com/support/sales](http://www.onsemi.com/support/sales)