

# CAT4137

## White LED Driver, CMOS Boost Converter

### Description

The CAT4137 is a DC/DC step-up converter that delivers a regulated output current. Operation at a constant switching frequency of 1 MHz allows the device to be used with small value external ceramic capacitors and inductor.

The device drives a string of white LEDs connected in series and provides the regulated current to control the LEDs with inherent uniform brightness and matching. An external resistor R1 sets the output current and allows up to 30 mA current to be supported over a wide range of input supply voltages from 2.2 V to 5.5 V, making the device ideal for battery-powered applications.

LED dimming can be done by using a DC voltage, a logic signal, or a pulse width modulation (PWM) signal. The shutdown control pin allows the device to be placed in power-down mode with “zero” quiescent current.

In addition to thermal protection and overload current limiting, the device also enters a very low power operating mode during “Open LED” fault conditions. The device is housed in a low profile (1 mm max height) 5-lead thin SOT23 package for space critical applications.

### Features

- Drives up to 5 White LEDs from 3 V
- Power Efficiency up to 87%
- Low Quiescent Ground Current 0.1 mA
- Adjustable Output Current (up to 30 mA)
- High Frequency 1 MHz Operation
- “Zero” Current Shutdown Mode
- Operates Down to 2 V (from Two AA Batteries)
- Soft Start Power-up
- Open LED Low Power Mode
- Automatic Shutdown at 1.9 V (UVLO)
- Thermal Shutdown Protection
- Thin SOT23 5-lead (1 mm Max Height)
- These Devices are Pb-Free, Halogen Free/BFR Free and are RoHS Compliant

### Applications

- LCD Backlighting
- Cellular Phones
- Handheld Devices
- Digital Cameras



ON Semiconductor®

<http://onsemi.com>



TSOT-23  
TD SUFFIX  
CASE 419AE

### PIN CONNECTIONS

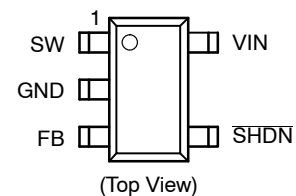

### MARKING DIAGRAMS

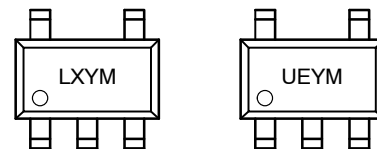

LX = CAT4137TD-T3  
UE = CAT4137TD-GT3  
Y = Production Year (Last Digit)  
M = Production Month (1-9, A, B, C)

### ORDERING INFORMATION (Note 3)

Device	Package	Shipping (Note 4)
CAT4137TD-T3 (Note 1)	TSOT-23 (Pb-Free)	3,000/ Tape & Reel
CAT4137TD-GT3 (Note 2)	TSOT-23 (Pb-Free)	3,000/ Tape & Reel

1. Matte-Tin Plated Finish (RoHS-compliant).
2. NiPdAu Plated Finish (RoHS-compliant)
3. For detailed information and a breakdown of device nomenclature and numbering systems, please see the ON Semiconductor Device Nomenclature document, TND310/D, available at [www.onsemi.com](http://www.onsemi.com)
4. For information on tape and reel specifications, including part orientation and tape sizes, please refer to our Tape and Reel Packaging Specifications Brochure, BRD8011/D.

# CAT4137

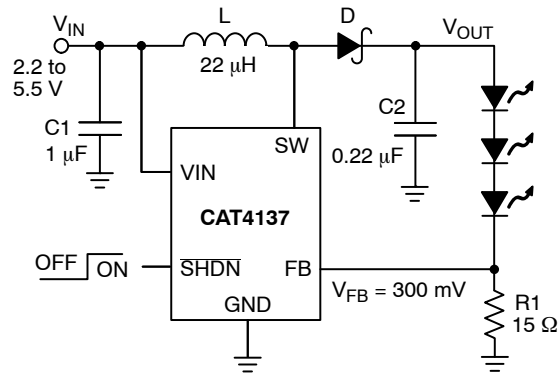

L: Murata LQH32CN220  
D: Central CMDSH2-3 (rated 30 V)

Figure 1. Typical Application Circuit

Table 1. ABSOLUTE MAXIMUM RATINGS

Parameter	Rating	Unit
V <sub>IN</sub> , FB voltage	-0.3 to +7	V
SHDN voltage	-0.3 to +7	V
SW voltage	-0.3 to +40	V
Storage Temperature Range	-65 to +160	°C
Junction Temperature Range	-40 to +150	°C
Lead Temperature	300	°C

Stresses exceeding Maximum Ratings may damage the device. Maximum Ratings are stress ratings only. Functional operation above the Recommended Operating Conditions is not implied. Extended exposure to stresses above the Recommended Operating Conditions may affect device reliability.

Table 2. RECOMMENDED OPERATING CONDITIONS

Parameter	Range	Unit
V <sub>IN</sub>	2.2 to 5.5	V
SW pin voltage	0 to 24	V
Ambient Temperature Range	-40 to +85	°C
LED Bias Current	1 to 30	mA

# CAT4137

**Table 3. ELECTRICAL OPERATING CHARACTERISTICS**

( $V_{IN} = 3.6\text{ V}$ , ambient temperature of  $25^{\circ}\text{C}$  (over recommended operating conditions unless otherwise specified))

Symbol	Parameter	Conditions	Min	Typ	Max	Unit
$I_Q$	Operating Current	$V_{FB} = 0.3\text{ V}$ $V_{FB} = 0.4\text{ V}$ (not switching)		0.4 0.1	1.5 0.3	mA
$I_{SD}$	Shutdown Current	$\overline{V_{SHDN}} = 0\text{ V}$		0.1	1	$\mu\text{A}$
$V_{FB}$	FB Pin Voltage	3 LEDs with $I_{LED} = 20\text{ mA}$	285	300	315	mV
$I_{FB}$	FB pin input leakage			0.1	1	$\mu\text{A}$
$I_{LED}$	Programmed LED Current	$R1 = 10\ \Omega$ $R1 = 15\ \Omega$ $R1 = 20\ \Omega$	28.5 19 14.25	30 20 15	31.5 21 15.75	mA
$V_{IH}$ $V_{IL}$	$\overline{SHDN}$ Logic High $\overline{SHDN}$ Logic Low	Enable Threshold Level Shutdown Threshold Level	0.4	0.8 0.7	1.5	V
$F_{SW}$	Switching Frequency		0.7	1.0	1.3	MHz
$I_{LIM}$	Switch Current Limit		250	300	400	mA
$R_{SW}$	Switch "On" Resistance	$I_{SW} = 100\text{ mA}$		1.0	2.0	$\Omega$
$I_{LEAK}$	Switch Leakage Current	Switch Off, $V_{SW} = 5\text{ V}$		1	5	$\mu\text{A}$
$T_{SD}$	Thermal Shutdown			150		$^{\circ}\text{C}$
$T_{HYS}$	Thermal Hysteresis			20		$^{\circ}\text{C}$
$\eta$	Efficiency	Typical Application Circuit		86		%
$V_{UVLO}$	Undervoltage Lockout (UVLO) Threshold			1.9		V
$V_{OV-SW}$	Output Clamp Voltage	"Open LED" fault		29		V

TYPICAL CHARACTERISTICS

( $V_{IN} = 3.6\text{ V}$ ,  $C_{IN} = 1.0\ \mu\text{F}$ ,  $C_{OUT} = 0.22\ \mu\text{F}$ ,  $L = 22\ \mu\text{H}$  with 3 LEDs at 20 mA,  $T_{AMB} = 25^\circ\text{C}$ , unless otherwise specified.)

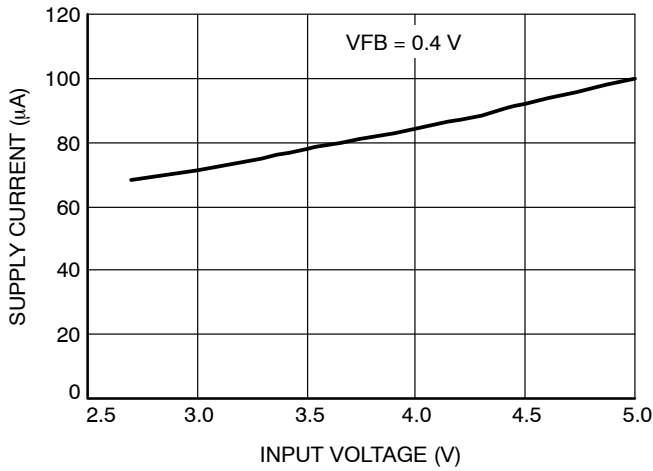

Figure 2. Quiescent Current vs.  $V_{IN}$   
(Not Switching)

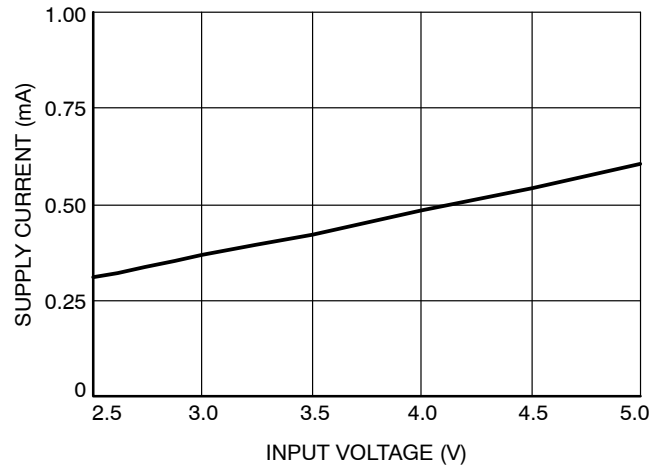

Figure 3. Quiescent Current vs.  $V_{IN}$   
(Switching)

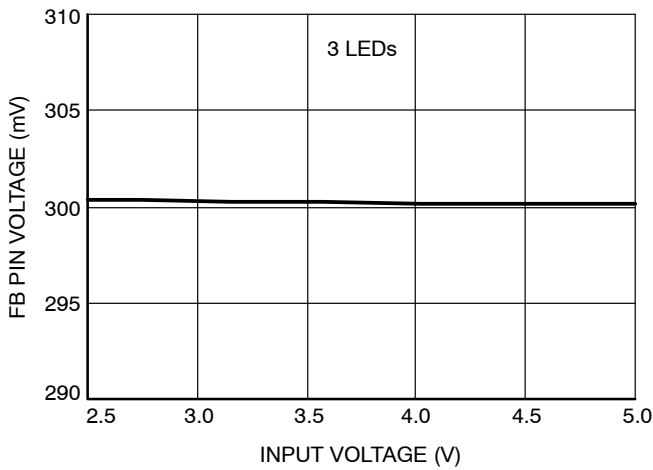

Figure 4. FB Pin Voltage vs. Supply Voltage

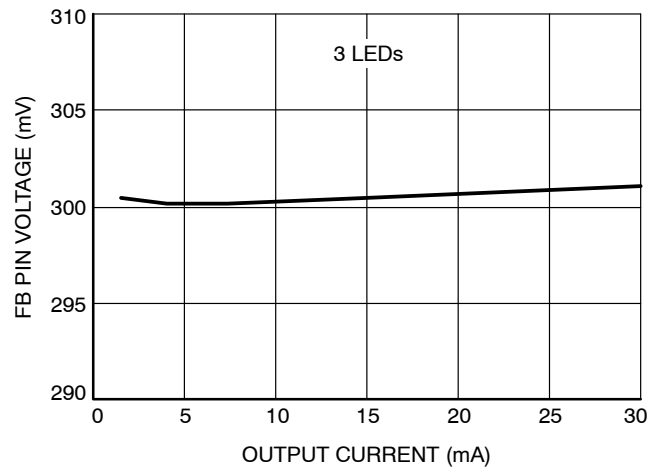

Figure 5. FB Pin Voltage vs. Output Current

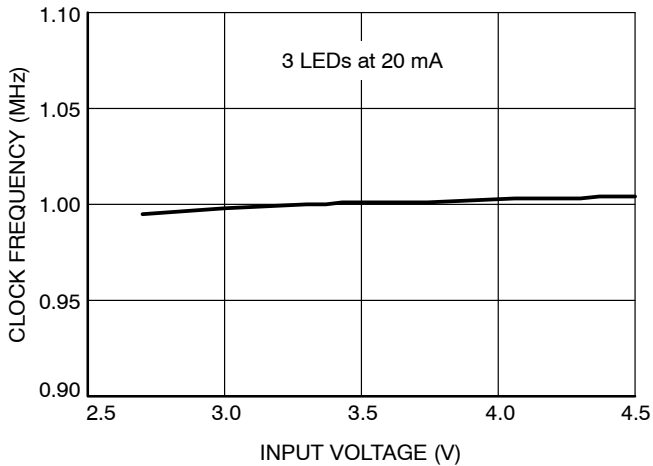

Figure 6. Switching Frequency vs. Supply  
Voltage

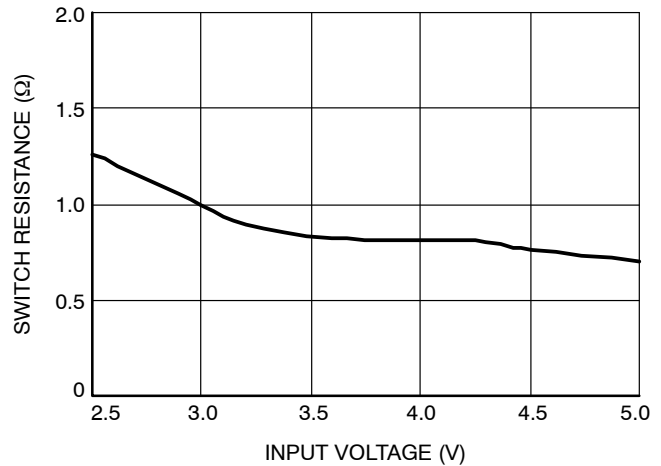

Figure 7. Switch ON Resistance vs.  
Input Voltage

TYPICAL CHARACTERISTICS

( $V_{IN} = 3.6\text{ V}$ ,  $C_{IN} = 1.0\ \mu\text{F}$ ,  $C_{OUT} = 0.22\ \mu\text{F}$ ,  $L = 22\ \mu\text{H}$  with 3 LEDs at 20 mA,  $T_{AMB} = 25^\circ\text{C}$ , unless otherwise specified.)

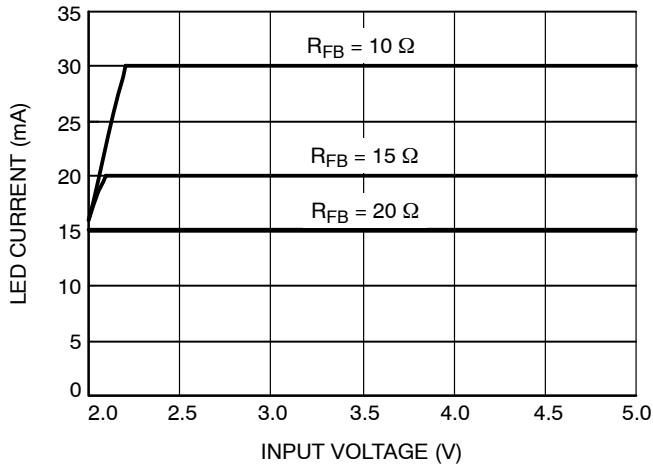

Figure 8. LED Current vs. Input Voltage (3 LEDs)

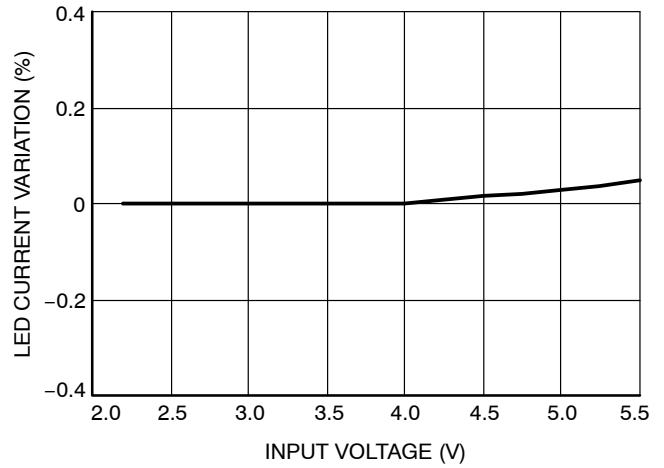

Figure 9. LED Current Regulation

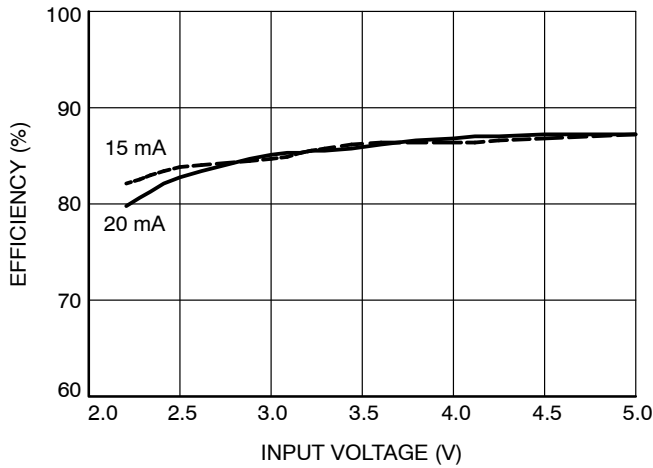

Figure 10. Efficiency across Supply Voltage (3 LEDs)

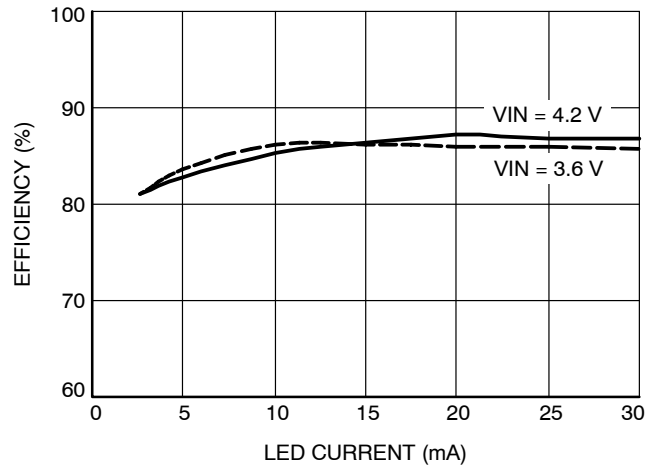

Figure 11. Efficiency across Load Current (3 LEDs)

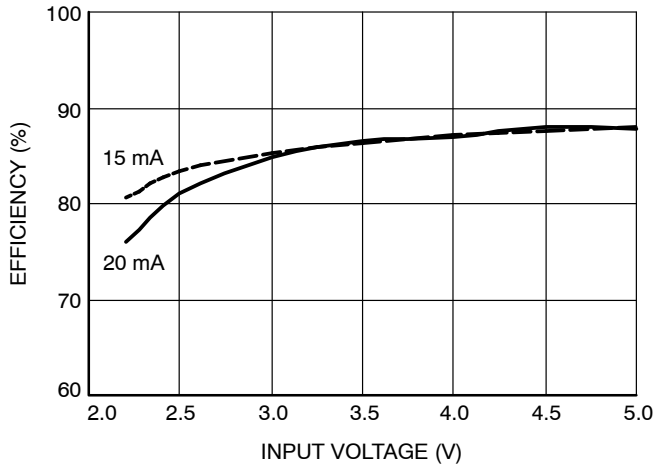

Figure 12. Efficiency across Supply Voltage (4 LEDs)

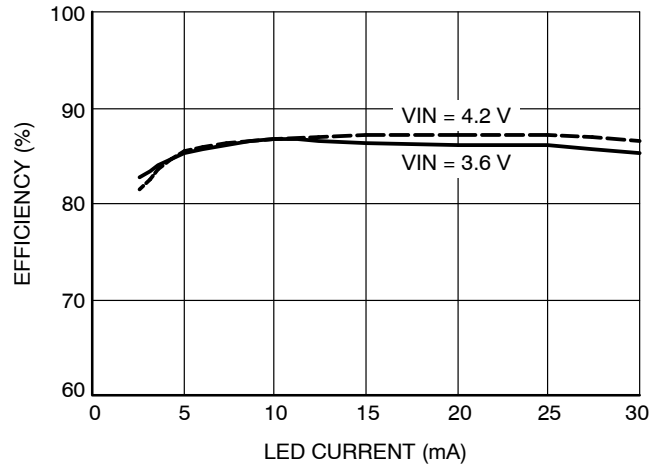

Figure 13. Efficiency across Load Current (4 LEDs)

# CAT4137

## TYPICAL CHARACTERISTICS

( $V_{IN} = 3.6\text{ V}$ ,  $C_{IN} = 1.0\ \mu\text{F}$ ,  $C_{OUT} = 0.22\ \mu\text{F}$ ,  $L = 22\ \mu\text{H}$  with 3 LEDs at 20 mA,  $T_{AMB} = 25^\circ\text{C}$ , unless otherwise specified.)

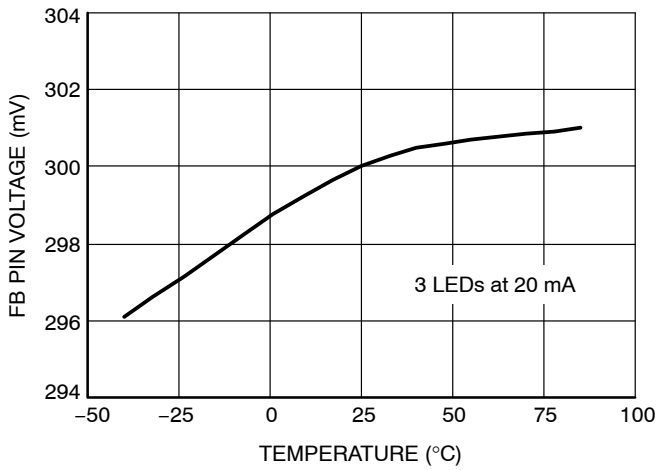

Figure 14. FB Pin Voltage vs. Temperature

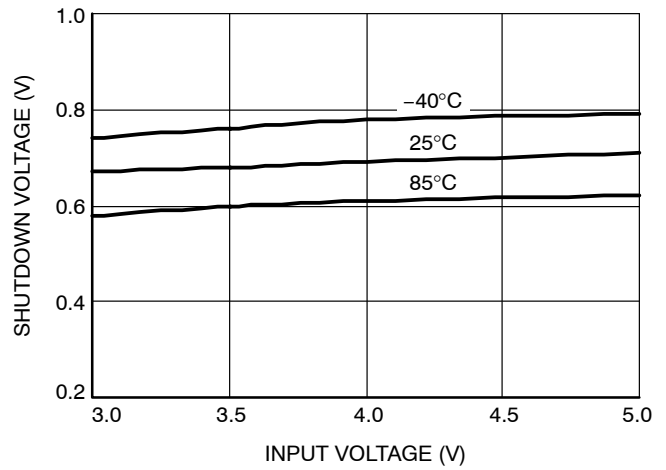

Figure 15. Shutdown Voltage vs. Input Voltage

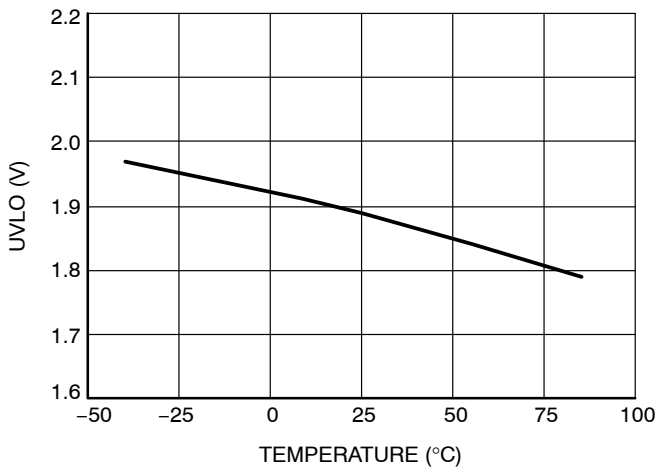

Figure 16. Under Voltage Lock Out vs. Temperature

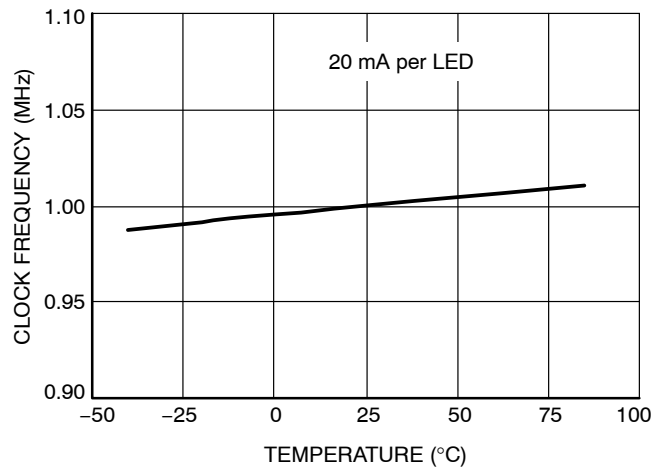

Figure 17. Switching Frequency vs. Temperature

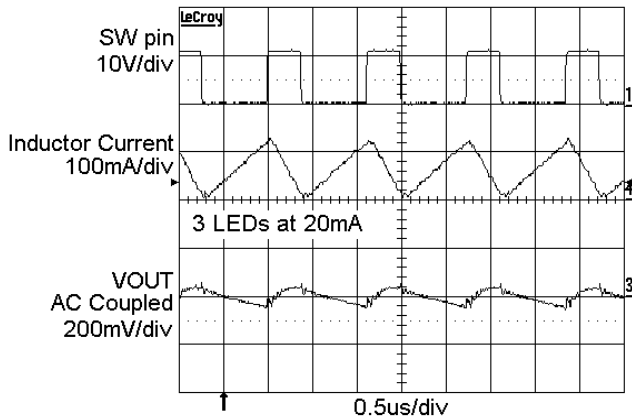

Figure 18. Switching Waveforms (3 LEDs in Series)

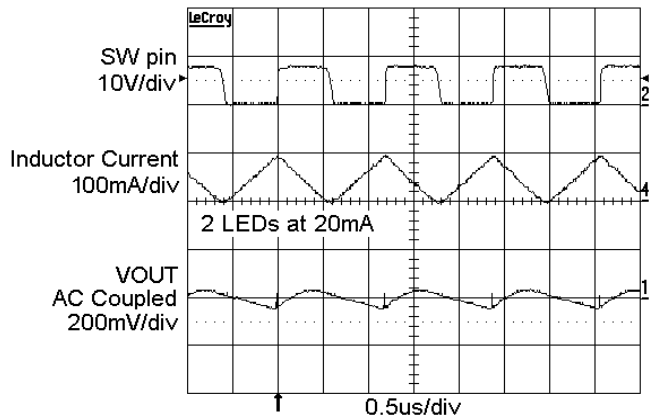

Figure 19. Switching Waveforms (2 LEDs in Series)

# CAT4137

## TYPICAL CHARACTERISTICS

( $V_{IN} = 3.6\text{ V}$ ,  $C_{IN} = 1.0\ \mu\text{F}$ ,  $C_{OUT} = 0.22\ \mu\text{F}$ ,  $L = 22\ \mu\text{H}$  with 3 LEDs at 20 mA,  $T_{AMB} = 25^\circ\text{C}$ , unless otherwise specified.)

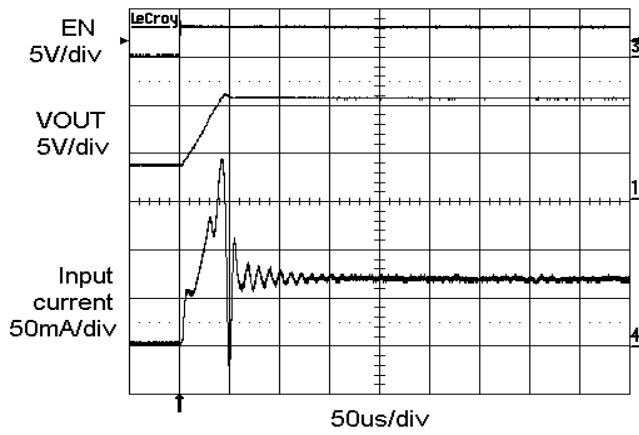

Figure 20. Power-up with 3 LEDs at 20 mA

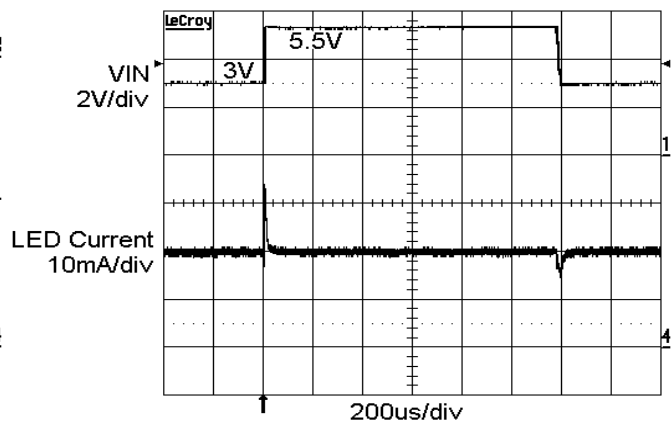

Figure 21. Line Transient Response (3 V – 5.5 V)

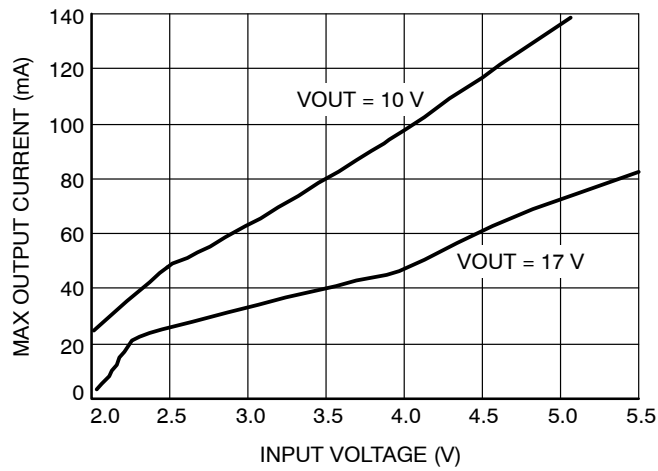

Figure 22. Maximum Output Current vs. Input Voltage

**Pin Description**

**VIN** is the supply input for the internal logic. The device is compatible with supply voltages down to 2.2 V and up to 5.5 V. A small bypass ceramic capacitor of 1 μF is recommended between the VIN and GND pins near the device. The under-voltage lockout (UVLO) circuitry will place the device into an idle mode (not switching) whenever the supply falls below 1.9 V.

**SHDN** is the shutdown logic input. When the pin voltage is taken below 0.4 V, the device immediately enters shutdown mode, drawing nearly zero current. At voltages greater than 1.5 V, the device becomes fully enabled and operational.

**GND** is the ground reference pin. This pin should be connected directly to the ground plane on the PCB.

**SW** pin is the drain terminal of the internal low resistance power switch. The inductor and the Schottky diode anode should be connected to the SW pin. Traces going to the SW pin should be as short as possible with minimum loop area. This pin contains over-voltage circuitry which becomes active above 24 V. In the event of an “Open-Led” fault condition, the device will enter a low power mode and the SW pin will be clamped to approximately 30 V.

**FB** feedback pin is regulated at 0.3 V. A resistor connected between the FB pin and ground sets the LED current according to the formula:

$$I_{LED} = \frac{0.3 V}{R1}$$

The lower LED cathode is connected to the FB pin.

**Table 4. PIN DESCRIPTIONS**

Pin #	Name	Function
1	SW	Switch pin. This is the drain of the internal power switch.
2	GND	Ground pin. Connect the pin to the ground plane.
3	FB	Feedback pin. Connect to the last LED cathode.
4	SHDN	Shutdown pin (Logic Low). Set high to enable the driver.
5	VIN	Power Supply input.



**Device Operation**

The CAT4137 is a fixed frequency (1 MHz), low noise, inductive boost converter providing constant current to the load. A high voltage internal CMOS power switch is used to energize the external inductor. When the power switch is then turned off, the stored energy inductor is released into the load via the external Schottky diode.

The on/off duty cycle of the power switch is internally adjusted and controlled to maintain a constant regulated voltage of 0.3 V across the external feedback resistor connected to the feedback pin (FB). The value of external resistor will accurately set the LED bias current accordingly ( $0.3 \text{ V}/R1$ ).

During the initial power-up stage, the duty cycle of the internal power switch is limited to prevent excessive in-rush currents and thereby provide a “soft-start” mode of operation.

While in normal operation, the device will comfortably deliver up to 30 mA of bias current into a string of up to 5 white LEDs.

In the event of a “Open-Led” fault condition, where the feedback control loop becomes open, the output voltage will continue to increase. Once this voltage exceeds 24 V, an internal protection circuit will become active and place the device into a very low power safe operating mode. In addition, an internal clamping circuit will limit the peak output voltage to 29 V. If this fault condition is repaired, the device will automatically resume normal operation.

Thermal overload protection circuitry has been included to prevent the device from operating at unsafe junction temperatures above 150°C. In the event of a thermal overload condition the device will automatically shutdown and wait till the junction temperatures cools to 130°C before normal operation is resumed.

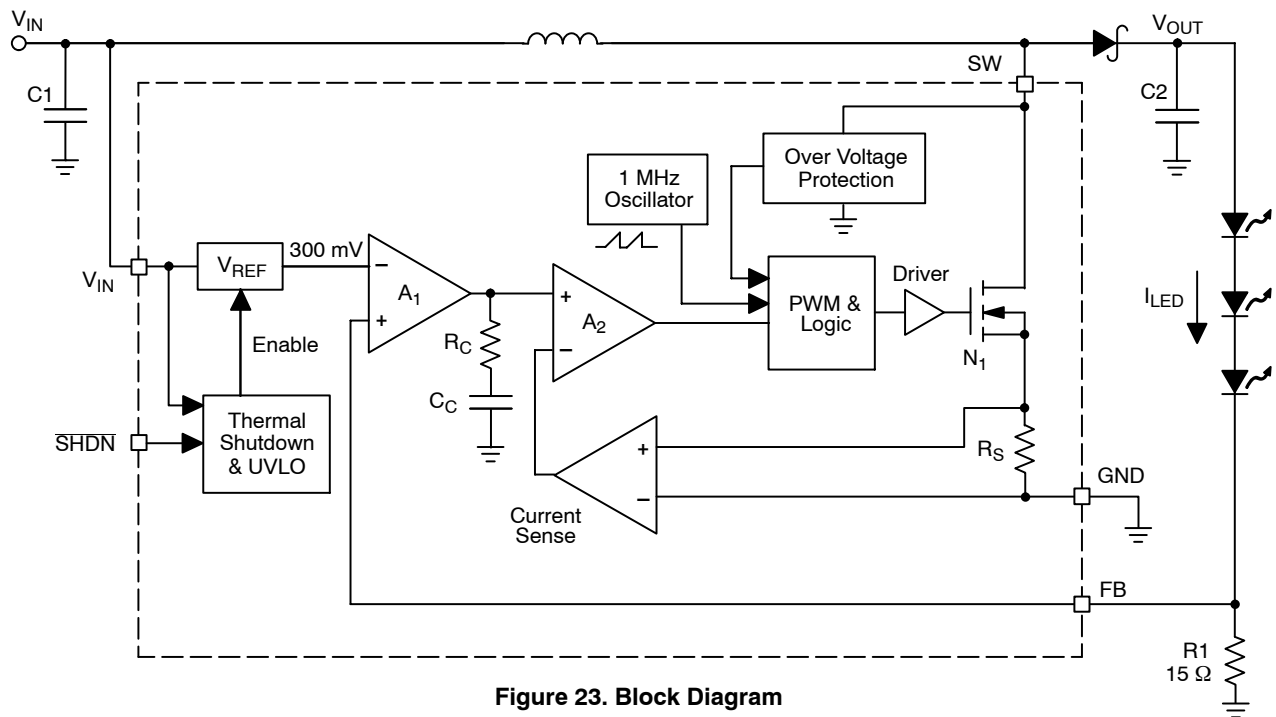

Figure 23. Block Diagram

**Application Information**  
**External Component Selection**

**Capacitors**

The CAT4137 only requires small ceramic capacitors of 1 μF on the input and 0.22 μF on the output. The output capacitor should be rated at 30 V or greater. Under normal conditions, a 1 μF input capacitor is sufficient. For applications with higher output power, a larger input capacitor of 2.2 μF or 4.7 μF may be appropriate. X5R and X7R capacitor types are ideal due to their stability across temperature range.

**Inductor**

A 22 μH inductor is recommended for most of the CAT4137 applications. In cases where the efficiency is critical, inductances with lower series resistance are preferred. Several inductor types from various vendors can be used. Figure 24 shows how different inductor types affect the efficiency across the load range.

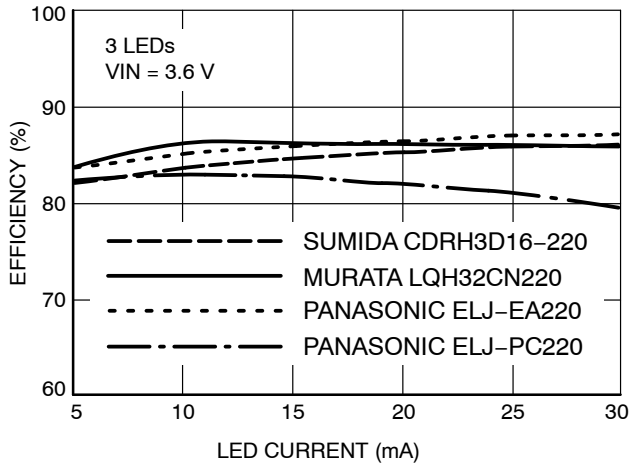

**Figure 24. Efficiency for Various Inductors**

**Schottky Diode**

The current rating of the Schottky diode must exceed the peak current flowing through it. The Schottky diode performance is rated in terms of its forward voltage at a given current. In order to achieve the best efficiency, this forward voltage should be as low as possible. The response time is also critical since the driver is operating at 1 MHz. Central Semiconductor Schottky CMDSH2-3 (200 mA rated) or the CMDSH-3 (100 mA rated) is recommended for most applications.

**LED Current Setting**

The LED current is set by the external resistor between the feedback pin (FB) and ground. The formula below gives the relationship between the resistor and the current:

$$R1 = \frac{0.3 V}{LED\ current}$$

**Table 5. RESISTOR R1 AND LED CURRENT**

LED Current (mA)	R1 (Ω)
5	60
10	30
15	20
20	15
25	12
30	10

# CAT4137

## Typical Applications

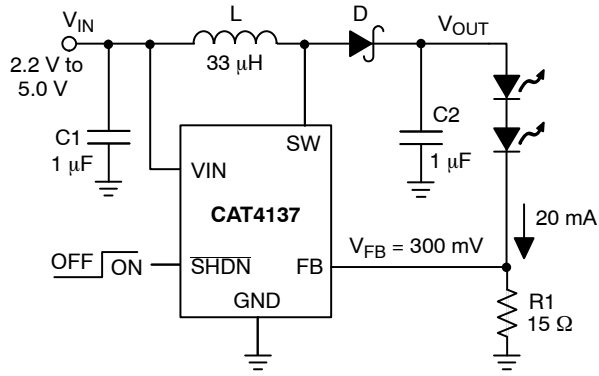

L: Sumida CDRH3D16-330  
 D: Central CMDSH2-3 (rated 30 V)  
 C2: Taiyo Yuden GMK212BJ105KG-T (rated 35 V)

**Figure 25. CAT4137 Driving Two LEDs**

For best performance, a 33  $\mu\text{H}$  inductor and a 1  $\mu\text{F}$  output capacitor are recommended for 2-LED applications.

In 2-LED configuration, the CAT4137 can be powered from two AA alkaline cells or from a Li-ion battery.

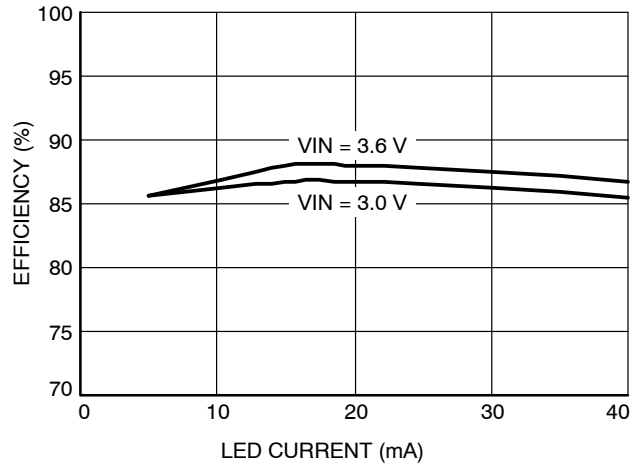

**Figure 26. Efficiency vs. LED Current, Two LEDs**

**Dimming Control**

There are several methods available to control the LED brightness.

**PWM Signal on the  $\overline{\text{SHDN}}$  Pin**

LED brightness dimming can be done by applying a PWM signal to the  $\overline{\text{SHDN}}$  input. The LED current is repetitively turned on and off, so that the average current is proportional to the duty cycle. A 100% duty cycle, with  $\overline{\text{SHDN}}$  always high, corresponds to the LEDs at nominal current. Figures 27 and 28 show 1 kHz and 4 kHz signals with a 50% duty cycle applied to the  $\overline{\text{SHDN}}$  pin. The PWM frequency range is from 100 Hz to 10 kHz. The recommended PWM frequency range is from 100 Hz to 4 kHz.

**Switching Waveforms PWM on  $\overline{\text{SHDN}}$**

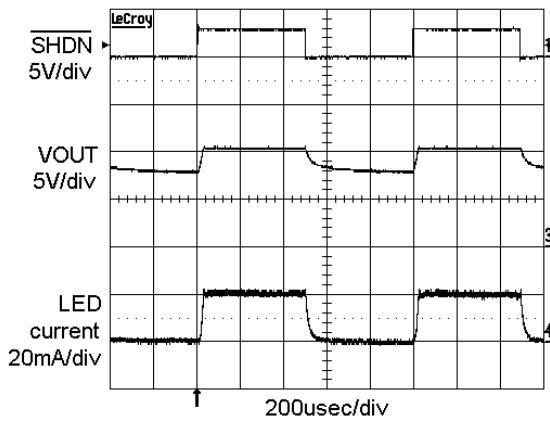

**Figure 27. PWM at 1 kHz**

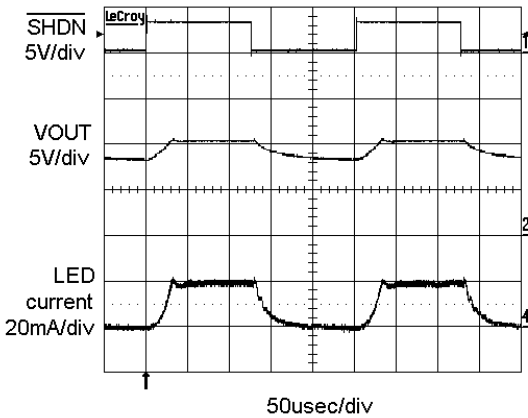

**Figure 28. PWM at 4 kHz**

**Filtered PWM Signal**

A filtered PWM signal can be used as a variable DC voltage that can be used to control the LED current. Figure 29 shows the PWM control circuitry connected to the CAT4137 FB pin. The PWM signal has a voltage swing of 0 V to 2.5 V. The LED current can be dimmed within a range from 0 to 22 mA. The PWM signal frequency can vary from very low frequency up to 100 kHz.

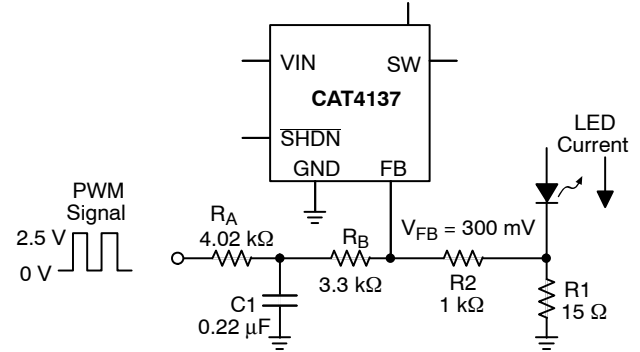

**Figure 29. Circuit for Filtered PWM Signal**

A PWM signal at 0 V DC, or a 0% duty cycle, results in a max LED current of about 22 mA. A PWM signal with a 100% duty cycle results in an LED current of 0 mA.

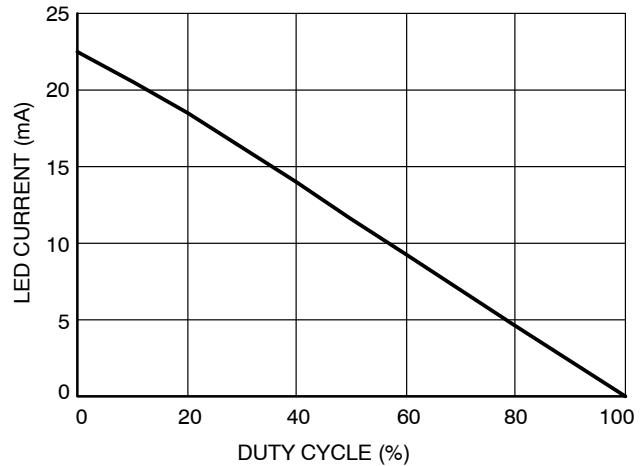

**Figure 30. LED Current vs. Duty Cycle**

**Open LED Protection**

In the event of an “Open LED” fault condition, the CAT4137 will continue to boost the output voltage with maximum power until the output voltage reaches approximately 24 V. Once the output exceeds this level, internal circuitry immediately places the device into a very low power mode where the total input power consumed is less than 10 mW.

In low power mode, the input supply current will typically drop to 2 mA. An internal clamping circuit will limit the subsequent output voltage to approximately 29 V. This operating mode eliminates the need for any external protection zener diode. This protection scheme also fully protects the device against any malfunction in the external Schottky diode (open-circuit).

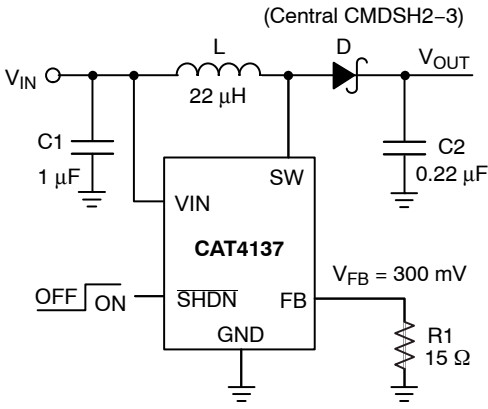

Figure 31. Open LED Protection

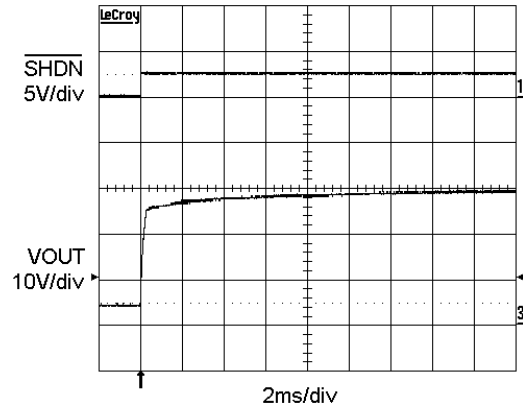

Figure 32. Open LED Power-up Waveforms

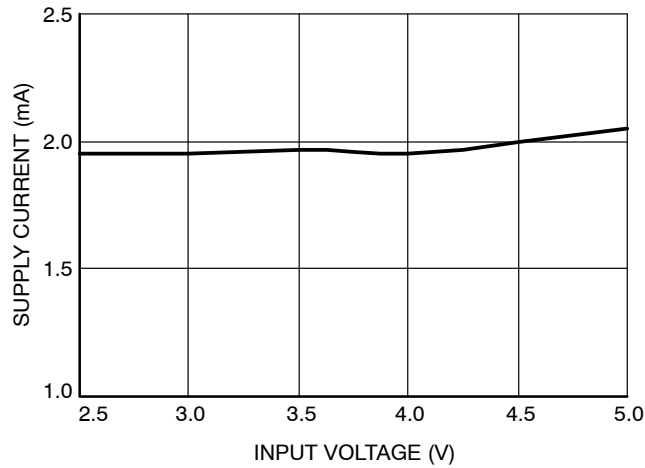

Figure 33. Open LED Supply Current vs. VIN

# CAT4137

## Board Layout

The CAT4137 is a high-frequency switching regulator. Traces carrying high-frequency switching current have to be carefully layout on the board in order to minimize EMI, ripple and noise in general. The thicker lines shown on Figure 34 indicate the switching current path. All these traces have to be short and wide enough to minimize the parasitic inductance and resistance. The loop shown on Figure 34 corresponds to the current path when the CAT4137 internal switch is closed. On Figure 35 is shown

the current loop when the CAT4137 switch is open. Both loop areas should be as small as possible.

Capacitor C1 has to be placed as close as possible to the VIN pin and GND. The capacitor C2 has to be connected separately to the top LED anode. A ground plane under the CAT4137 allows for direct connection of the capacitors to ground. The resistor R1 must be connected directly to the GND pin of the CAT4137 and not shared with the switching current loops and any other components.

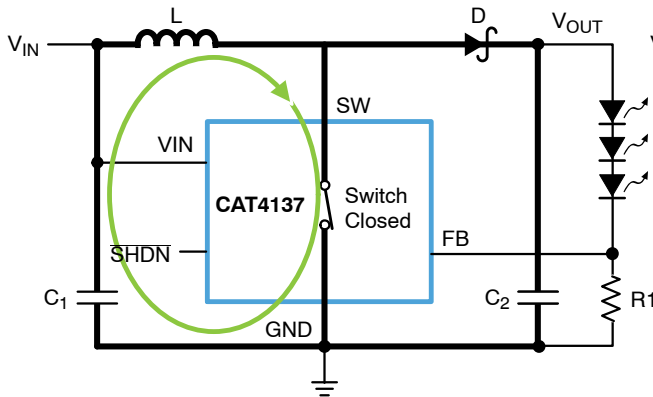

Figure 34. Closed-switch Current Loop

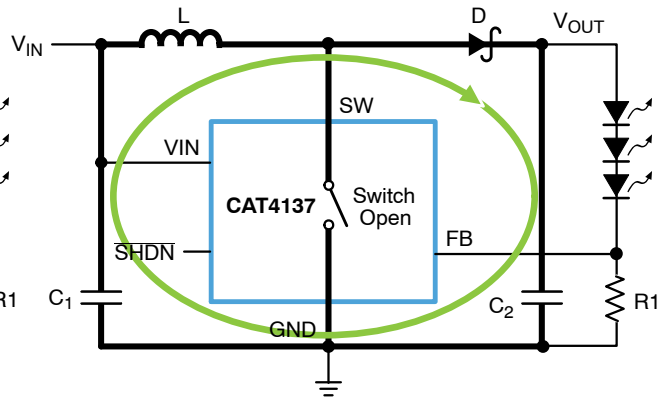

Figure 35. Open-switch Current Loop

# MECHANICAL CASE OUTLINE

## PACKAGE DIMENSIONS

ON Semiconductor®



TSOT-23, 5 LEAD  
CASE 419AE-01  
ISSUE O

DATE 19 DEC 2008

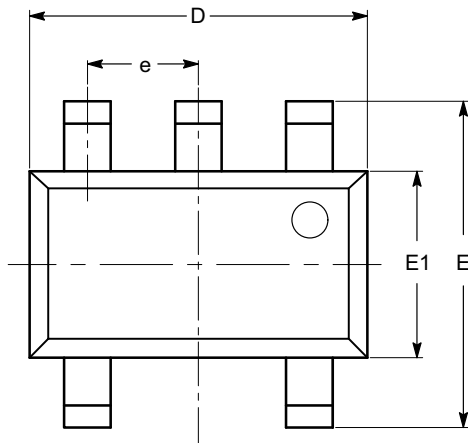

TOP VIEW

SYMBOL	MIN	NOM	MAX
A			1.00
A1	0.01	0.05	0.10
A2	0.80	0.87	0.90
b	0.30		0.45
c	0.12	0.15	0.20
D	2.90 BSC		
E	2.80 BSC		
E1	1.60 BSC		
e	0.95 TYP		
L	0.30	0.40	0.50
L1	0.60 REF		
L2	0.25 BSC		
$\theta$	0°		8°

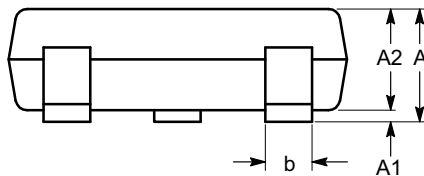

SIDE VIEW

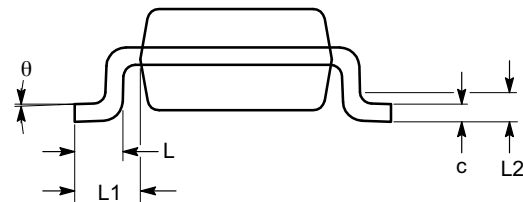

END VIEW

**Notes:**

- (1) All dimensions are in millimeters. Angles in degrees.
- (2) Complies with JEDEC MO-193.

<b>DOCUMENT NUMBER:</b>	<b>98AON34392E</b>	Electronic versions are uncontrolled except when accessed directly from the Document Repository. Printed versions are uncontrolled except when stamped "CONTROLLED COPY" in red.
<b>DESCRIPTION:</b>	<b>TSOT-23, 5 LEAD</b>	<b>PAGE 1 OF 1</b>

ON Semiconductor and are trademarks of Semiconductor Components Industries, LLC dba ON Semiconductor or its subsidiaries in the United States and/or other countries. ON Semiconductor reserves the right to make changes without further notice to any products herein. ON Semiconductor makes no warranty, representation or guarantee regarding the suitability of its products for any particular purpose, nor does ON Semiconductor assume any liability arising out of the application or use of any product or circuit, and specifically disclaims any and all liability, including without limitation special, consequential or incidental damages. ON Semiconductor does not convey any license under its patent rights nor the rights of others.

**onsemi**, **Onsemi**, and other names, marks, and brands are registered and/or common law trademarks of Semiconductor Components Industries, LLC dba "**onsemi**" or its affiliates and/or subsidiaries in the United States and/or other countries. **onsemi** owns the rights to a number of patents, trademarks, copyrights, trade secrets, and other intellectual property. A listing of **onsemi**'s product/patent coverage may be accessed at [www.onsemi.com/site/pdf/Patent-Marking.pdf](http://www.onsemi.com/site/pdf/Patent-Marking.pdf). **onsemi** reserves the right to make changes at any time to any products or information herein, without notice. The information herein is provided "as-is" and **onsemi** makes no warranty, representation or guarantee regarding the accuracy of the information, product features, availability, functionality, or suitability of its products for any particular purpose, nor does **onsemi** assume any liability arising out of the application or use of any product or circuit, and specifically disclaims any and all liability, including without limitation special, consequential or incidental damages. Buyer is responsible for its products and applications using **onsemi** products, including compliance with all laws, regulations and safety requirements or standards, regardless of any support or applications information provided by **onsemi**. "Typical" parameters which may be provided in **onsemi** data sheets and/or specifications can and do vary in different applications and actual performance may vary over time. All operating parameters, including "Typicals" must be validated for each customer application by customer's technical experts. **onsemi** does not convey any license under any of its intellectual property rights nor the rights of others. **onsemi** products are not designed, intended, or authorized for use as a critical component in life support systems or any FDA Class 3 medical devices or medical devices with a same or similar classification in a foreign jurisdiction or any devices intended for implantation in the human body. Should Buyer purchase or use **onsemi** products for any such unintended or unauthorized application, Buyer shall indemnify and hold **onsemi** and its officers, employees, subsidiaries, affiliates, and distributors harmless against all claims, costs, damages, and expenses, and reasonable attorney fees arising out of, directly or indirectly, any claim of personal injury or death associated with such unintended or unauthorized use, even if such claim alleges that **onsemi** was negligent regarding the design or manufacture of the part. **onsemi** is an Equal Opportunity/Affirmative Action Employer. This literature is subject to all applicable copyright laws and is not for resale in any manner.

## PUBLICATION ORDERING INFORMATION

### LITERATURE FULFILLMENT:

Email Requests to: [orderlit@onsemi.com](mailto:orderlit@onsemi.com)

**onsemi Website:** [www.onsemi.com](http://www.onsemi.com)

### TECHNICAL SUPPORT

**North American Technical Support:**  
Voice Mail: 1 800-282-9855 Toll Free USA/Canada  
Phone: 011 421 33 790 2910

**Europe, Middle East and Africa Technical Support:**

Phone: 00421 33 790 2910

For additional information, please contact your local Sales Representative