

ADM1023

ACPI-Compliant, High Accuracy Microprocessor System Temperature Monitor

The ADM1023 is a 2-channel digital thermometer and under/overtemperature alarm for use in personal computers and other systems requiring thermal monitoring and management. Optimized for the Pentium® III, the higher accuracy allows systems designers to safely reduce temperature guard banding and increase system performance. The device can measure the temperature of a microprocessor using a diode-connected PNP transistor, which may be provided on-chip with the Pentium® III or similar processors; or it can be a low-cost, discrete NPN/PNP device such as the 2N3904/2N3906. A novel measurement technique cancels out the absolute value of the transistor's base emitter voltage so that no calibration is required. The second measurement channel measures the output of an on-chip temperature sensor to monitor the temperature of the device and its environment.

The ADM1023 communicates over a 2-wire serial interface compatible with SMBus standards. Under/overtemperature limits can be programmed into the device over the serial bus, and an ALERT output signals when the on-chip or remote temperature is out of range. This output can be used as an interrupt or as an SMBus ALERT.

Features

- Next Generation Upgrade of ADM1021
- On-Chip and Remote Temperature Sensing
- Offset Registers for System Calibration
- 1°C Accuracy and Resolution on Local Channel
- 0.125°C Resolution/1°C Accuracy on Remote Channel
- Programmable Over/Undertemperature Limits
- Programmable Conversion Rate
- Supports System Management Bus (SMBus) ALERT
- 2-Wire SMBus Serial Interface
- 200 µA Max Operating Current (0.25 Conversions/Second)
- 1 µA Standby Current
- 3.0 V to 5.5 V Supply
- Small 16-Lead QSOP Package
- This is a Pb-Free Package*

Applications

- Desktop Computers
- Notebook Computers
- Smart Batteries
- Industrial Controllers
- Telecomm Equipment
- Instrumentation

*For additional information on our Pb-Free strategy and soldering details, please download the ON Semiconductor Soldering and Mounting Techniques Reference Manual, SOLDERRM/D.



ON Semiconductor®

<http://onsemi.com>

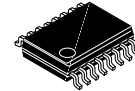

QSOP 16
CASE 492

PIN ASSIGNMENT

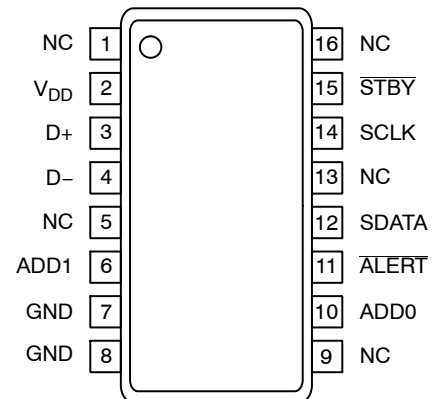

ADM1023
(Top View)

MARKING DIAGRAM

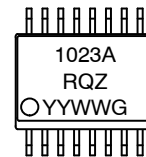

1023ARQZ = Specific Device Code
YY = Year
WW = Work Week
G = Pb-Free Package

ORDERING INFORMATION

See detailed ordering and shipping information in the package dimensions section on page 15 of this data sheet.

ADM1023

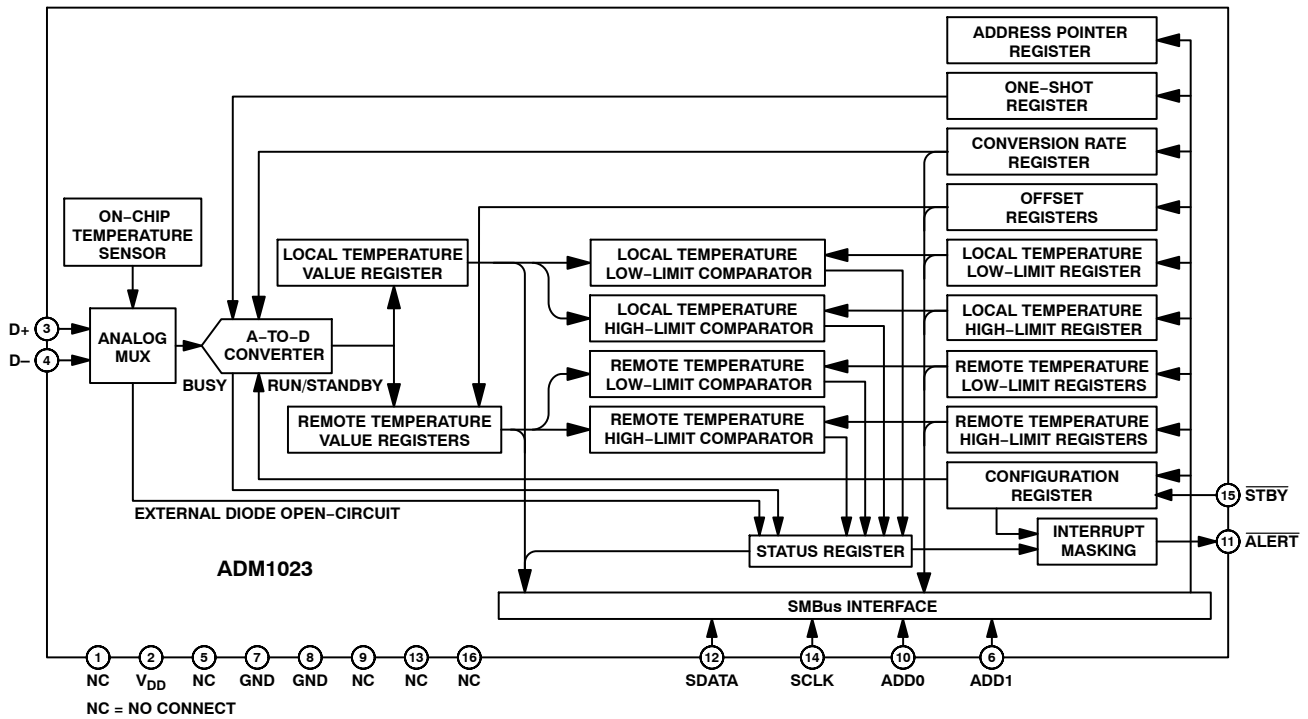

Figure 1. Functional Block Diagram

Table 1. ABSOLUTE MAXIMUM RATINGS

Parameter	Rating	Unit
Positive Supply Voltage (V_{DD}) to GND	-0.3 to +6.0	V
D+, ADD0, ADD1	-0.3 to $V_{DD} + 0.3$	V
D- to GND	-0.3 to +0.6	
SCLK, SDATA, ALERT, STBY	-0.3 to +6.0	V
Input Current	± 50	mA
Input Current, D-	± 10	mA
ESD Rating, All Pins (Human Body Model)	2000	V
Continuous Power Dissipation Up to 70°C Derating Above 70°C	650 6.7	mW mW/°C
Operating Temperature Range	-55 to +125	°C
Maximum Junction Temperature (T_{Jmax})	150	°C
Storage Temperature Range	-65 to +150	°C
Lead Temperature, Soldering (10 s)	300	°C
IR Reflow Peak Temperature	220	°C
IR Reflow Peak Temperature for Pb-Free	260	°C

Stresses exceeding Maximum Ratings may damage the device. Maximum Ratings are stress ratings only. Functional operation above the Recommended Operating Conditions is not implied. Extended exposure to stresses above the Recommended Operating Conditions may affect device reliability.

NOTE: This device is ESD sensitive. Use standard ESD precautions when handling.

Table 2. THERMAL CHARACTERISTICS

Parameter	Rating
16-Lead QSOP Package	$\theta_{JA} = 105^{\circ}\text{C}/\text{W}$, $\theta_{JC} = 39^{\circ}\text{C}/\text{W}$

ADM1023

Table 3. PIN ASSIGNMENT

Pin No.	Mnemonic	Description
1	NC	No Connect
2	V _{DD}	Positive Supply, 3.0 V to 5.5 V
3	D+	Positive Connection to Remote Temperature Sensor
4	D-	Negative Connection to Remote Temperature Sensor
5	NC	No Connect
6	ADD1	Three-state Logic Input, Higher Bit of Device Address
7	GND	Supply 0 V Connection
8	GND	Supply 0 V Connection
9	NC	No Connect
10	ADD0	Three-state Logic Input, Lower Bit of Device Address
11	$\overline{\text{ALERT}}$	Open-drain Logic Output Used as Interrupt or SMBus $\overline{\text{ALERT}}$
12	SDATA	Logic Input/Output, SMBus Serial Data. Open-drain Output
13	NC	No Connect
14	SCLK	Logic Input, SMBus Serial Clock
15	$\overline{\text{STBY}}$	Logic Input Selecting Normal Operation (High) or Standby Mode (Low)
16	NC	No Connect

Table 4. ELECTRICAL CHARACTERISTICS ($T_A = T_{\text{MIN}}$ to T_{MAX} , $V_{\text{DD}} = 3.0 \text{ V}$ to 3.6 V , unless otherwise noted. (Note 1)

Parameter	Test Conditions/Comments	Min	Typ	Max	Unit
Power Supply and ADC					
Temperature Resolution, Local Sensor	Guaranteed No Missed Codes	1.0	–	–	°C
Temperature Resolution, Remote Sensor	Guaranteed No Missed Codes	0.125	–	–	°C
Temperature Error, Local Sensor	$T_A = 60^\circ\text{C}$ to 100°C $T_A = 0^\circ\text{C}$ to 120°C	–1.5 –3.0	± 0.5 ± 1.0	+1.5 +3.0	°C
Temperature Error, Remote Sensor	$T_A, T_D = 60^\circ\text{C}$ to 100°C (Note 2)	–1.0	–	+1.0	°C
	$T_A, T_D = 0^\circ\text{C}$ to 120°C (Note 2)	–3.0	–	+3.0	°C
Relative Accuracy	$T_A = 60^\circ\text{C}$ to 100°C	–	–	0.25	°C
Supply Voltage Range (Note 3)		3.0	–	3.6	V
Undervoltage Lockout Threshold	V_{DD} Input, Disables ADC, Rising Edge	2.55	2.7	2.8	V
Undervoltage Lockout Hysteresis		–	25	–	mV
Power-on Reset Threshold	V_{DD} , Falling Edge (Note 4)	0.9	1.7	2.2	V
POR Threshold Hysteresis		–	50	–	mV
Standby Supply Current	$V_{\text{DD}} = 3.3 \text{ V}$, No SMBus Activity SCLK at 10 kHz	–	1.0 4.0	5.0 –	μA
Average Operating Supply Current	0.25 Conversions/Sec Rate	–	130	200	μA
Autoconvert Mode, Averaged Over 4 Sec	2 Conversions/Sec Rate	–	225	370	μA
Conversion Time	From Stop Bit to Conversion Complete (Both Channels) D+ Forced to D- + 0.65 V	65	115	170	ms
Remote Sensor Source Current	High Level (Note 4) Low Level (Note 4)	120 7.0	205 12	300 16	μA
D- Source Voltage		–	0.7	–	V
Address Pin Bias Current (ADD0, ADD1)	Momentary at Power-on Reset	–	50	–	μA

ADM1023

Table 4. ELECTRICAL CHARACTERISTICS ($T_A = T_{MIN}$ to T_{MAX} , $V_{DD} = 3.0$ V to 3.6 V, unless otherwise noted. (Note 1)

Parameter	Test Conditions/Comments	Min	Typ	Max	Unit
SMBus Interface (See Figure 2)					
Logic Input High Voltage, V_{IH} STBY, SCLK, SDATA	$V_{DD} = 3.0$ V to 5.5 V	2.2	–	–	V
Logic Input Low Voltage, V_{IL} STBY, SCLK, SDATA	$V_{DD} = 3.0$ V to 5.5 V	–	–	0.8	V
SMBus Output Low Sink Current	SDATA Forced to 0.6 V	6.0	–	–	mA
ALERT Output Low Sink Current	ALERT Forced to 0.4 V	1.0	–	–	mA
Logic Input Current, I_{IH} , I_{IL}		–1.0	–	+1.0	μ A
SMBus Input Capacitance, SCLK, SDATA		–	5.0	–	pF
SMBus Clock Frequency		–	–	400	kHz
SMBus Clock Low Time, t_{LOW}	t_{LOW} between 10% Points	1.3	–	–	μ s
SMBus Clock High Time, t_{HIGH}	t_{HIGH} between 90% Points	0.6	–	–	μ s
SMBus Start Condition Setup Time, $t_{SU:STA}$		0.6	–	–	μ s
SMBus Start Condition Hold Time, $t_{HD:STA}$	Time from 10% of SDATA to 90% of SCLK	0.6	–	–	μ s
SMBus Stop Condition Setup Time, $t_{SU:STO}$	Time from 90% of SCLK to 10% of SDATA	0.6	–	–	μ s
SMBus Data Valid to SCLK Rising Edge Time, $t_{SU:DAT}$	Time for 10% or 90% of SDATA to 10% of SCLK	100	–	–	ns
SMBus Bus Free Time, t_{BUF}	Between Start/Stop Condition	1.3	–	–	μ s
SCLK SDATA Rise Time, $t_{R MAX}$	Master Clocking in Data	–	–	300	ns
SCLK SDATA Fall Time, $t_{F MAX}$	$V_{DD} = 0$ V	–	–	300	ns

1. $T_{MAX} = 120^{\circ}\text{C}$, $T_{MIN} = 0^{\circ}\text{C}$
2. T_D is the temperature of the remote thermal diode; T_A , $T_D = 60^{\circ}\text{C}$ to 100°C
3. Operation at $V_{DD} = 5.0$ V guaranteed by design; not production tested
4. Guranteed by design; not production tested

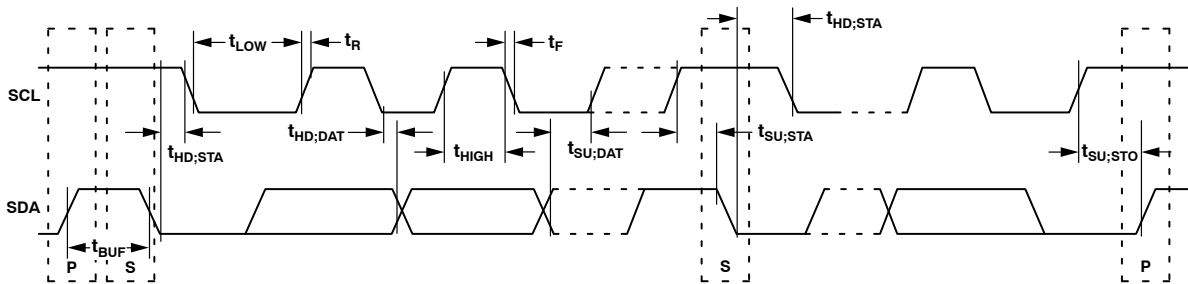

Figure 2. Diagram for Serial Bus Timing

TYPICAL PERFORMANCE CHARACTERISTICS

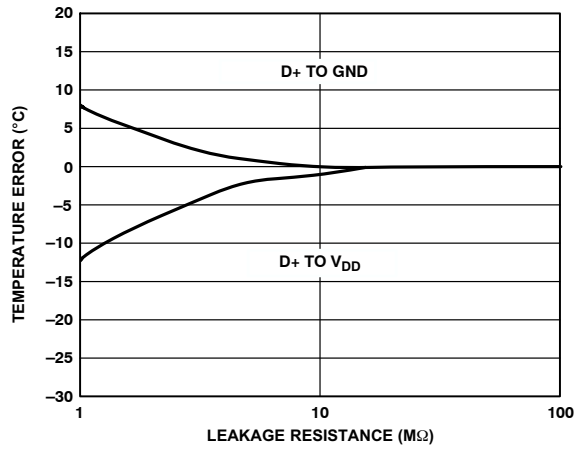

Figure 3. Temperature Error vs. Resistance from Track to V_{DD} and GND

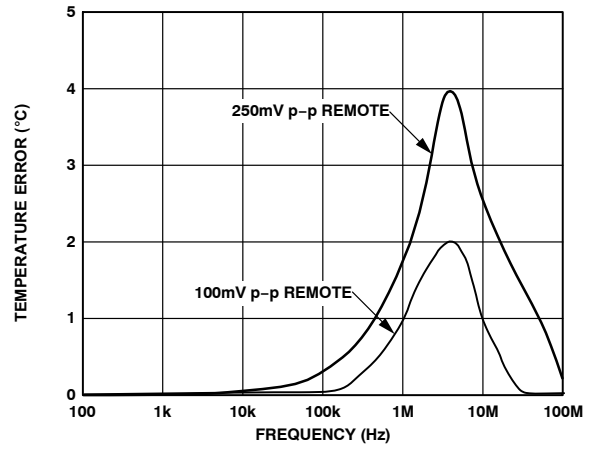

Figure 4. Remote Temperature Error vs. Supply Noise Frequency

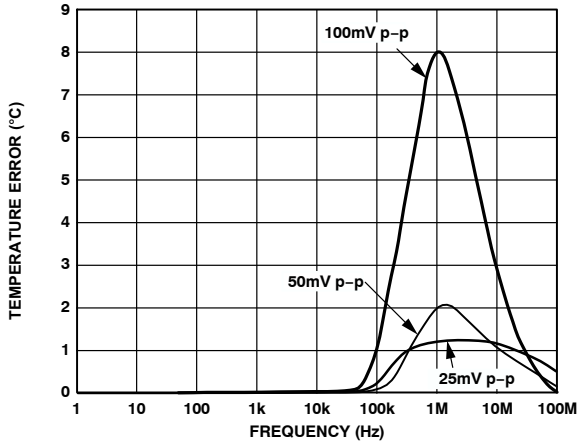

Figure 5. Temperature Error vs. Common-mode Noise Frequency

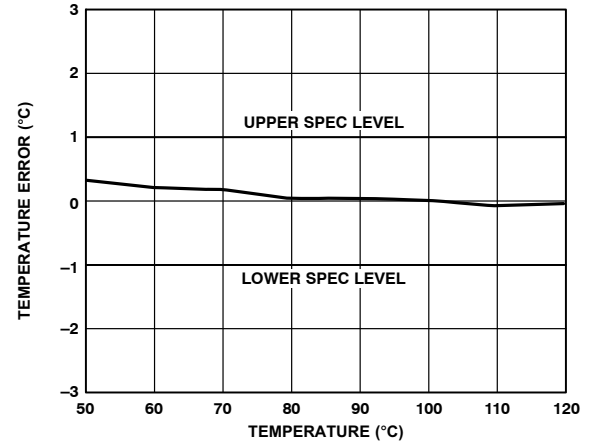

Figure 6. Temperature Error of ADM1023 vs. Pentium III Temperature

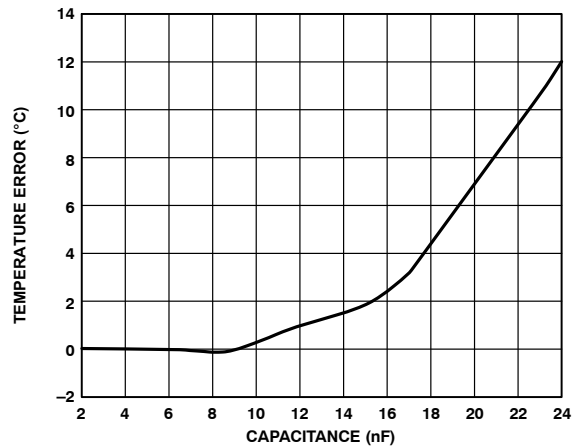

Figure 7. Temperature Error vs. Capacitance Between $D+$ and $D-$

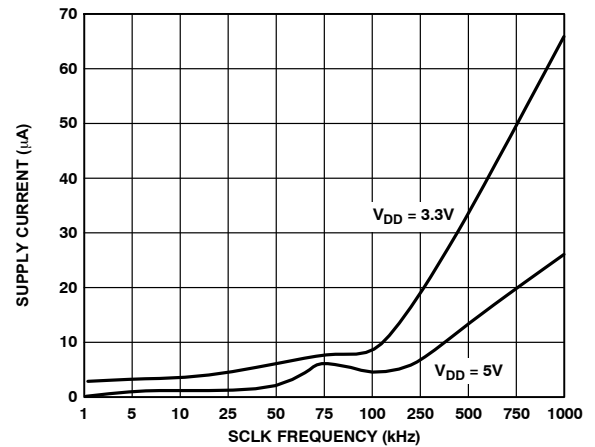

Figure 8. Standby Supply Current vs. SCLK Frequency

TYPICAL PERFORMANCE CHARACTERISTICS

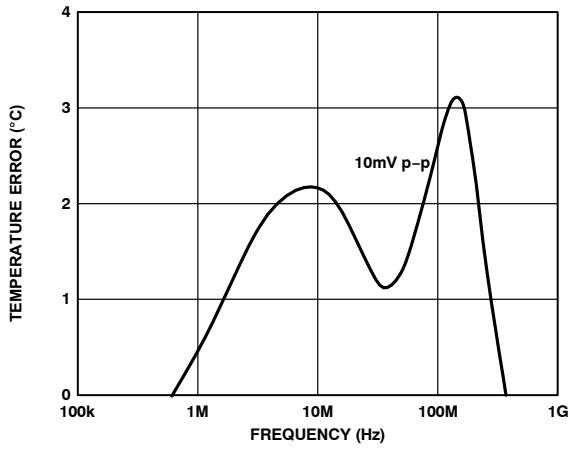

Figure 9. Temperature Error vs. Differential-mode Noise Frequency

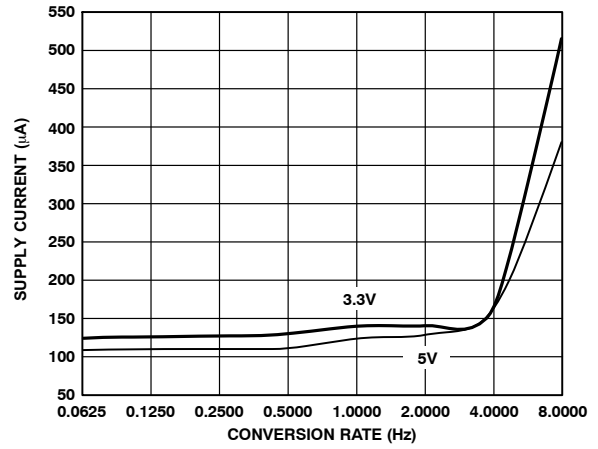

Figure 10. Operating Supply Current vs. Conversion Rate, $V_{DD} = 5.0\text{ V}$ and 3.3 V

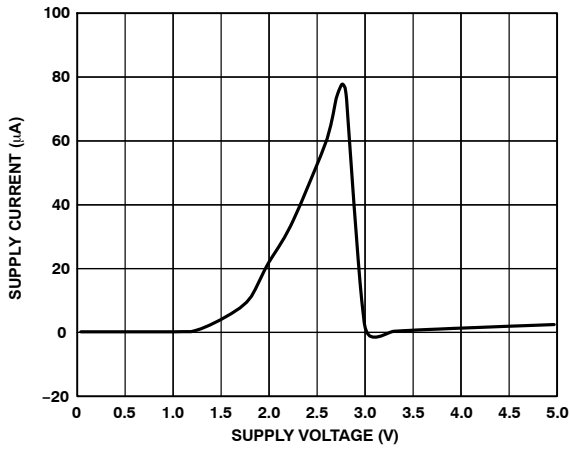

Figure 11. Standby Supply Current vs. Supply Voltage

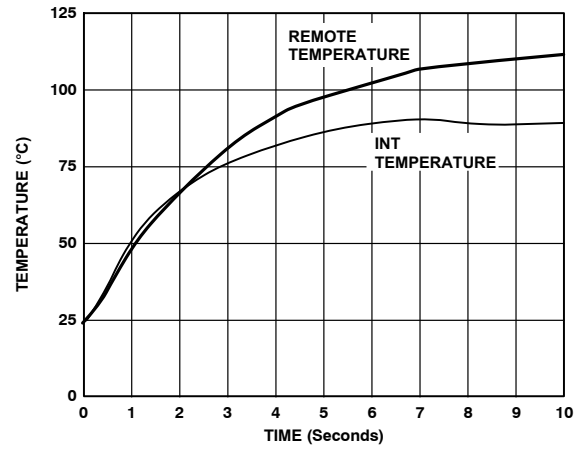

Figure 12. Response to Thermal Shock

Theory of Operation

Functional Description

The ADM1023 contains a two-channel analog-to-digital converter (ADC) with special input-signal conditioning to enable operation with remote and on-chip diode temperature sensors. When the ADM1023 is operating normally, the ADC operates in a free-running mode. The analog input multiplexer alternately selects either the on-chip temperature sensor to measure its local temperature or the remote temperature sensor. These signals are digitized by the ADC, and the results are stored in the local and remote temperature value registers. Only the eight most significant bits (MSBs) of the local temperature value are stored as an 8-bit binary word. The remote temperature value is stored as an 11-bit binary word in two registers. The eight MSBs are stored in the remote temperature value high byte register at Address 0x01. The three least significant bits (LSBs) are stored, left justified, in the remote temperature value low byte register at Address 0x10.

Error sources such as PCB track resistance and clock noise can introduce offset errors into measurements on the remote channel. To achieve the specified accuracy on this channel, these offsets must be removed, and two offset registers are provided for this purpose at Address 0x11 and Address 0x12.

An offset value may automatically be added to or subtracted from the measurement by writing an 11-bit, twos complement value to Register 0x11 (high byte) and Register 0x12 (low byte, left-justified).

The offset registers default to 0 at powerup and have no effect if nothing is written to them.

The measurement results are compared with local and remote, high and low temperature limits, stored in six

on-chip limit registers. As with the measured value, the local temperature limits are stored as 8-bit values and the remote temperature limits as 11-bit values. Out-of-limit comparisons generate flags that are stored in the status register, and one or more out-of-limit results cause the $\overline{\text{ALERT}}$ output to pull low.

Registers can be programmed, and the device controlled and configured, via the serial system management bus (SMBus). The contents of any register can also be read back via the SMBus.

Control and configuration functions consist of:

- Switching the Device between Normal Operation and Standby Mode
- Masking or Enabling the $\overline{\text{ALERT}}$ Output
- Selecting the Conversion Rate

On initial powerup, the remote and local temperature values default to -128°C . The device normally powers up converting, making a measure of local and remote temperature. These values are then stored before making a comparison with the stored limits. However, if the part is powered up in standby mode ($\overline{\text{STBY}}$ pin pulled low), no new values are written to the register before a comparison is made. As a result, both RLOW and LLOW are tripped in the status register, thus generating an $\overline{\text{ALERT}}$ output. This may be cleared in one of two ways:

- Change both the local and remote lower limits to -128°C and read the status register (which in turn clears the $\overline{\text{ALERT}}$ output).
- Take the part out of standby and read the status register (which in turn clears the $\overline{\text{ALERT}}$ output). This works only when the measured values are within the limit values.

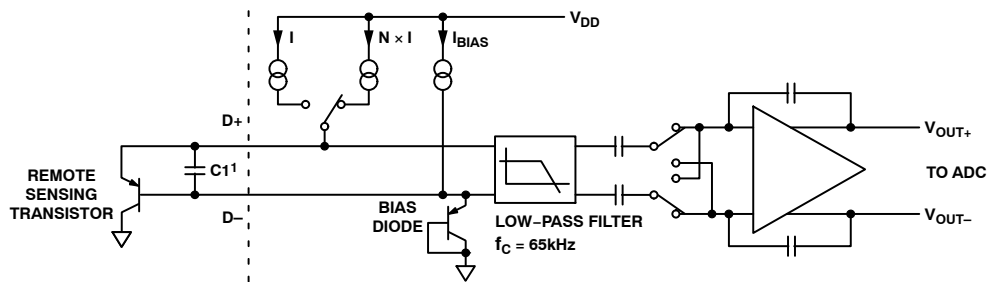

¹CAPACITOR C1 IS OPTIONAL. IT IS ONLY NECESSARY IN NOISY ENVIRONMENTS. C1 = 1000pF MAX.

Figure 13. Input Signal Conditioning

Measurement Method

A simple method of measuring temperature is to exploit the negative temperature coefficient of a diode, or the base emitter voltage of a transistor, operating at constant current. Thus, the temperature may be obtained from a direct measurement of V_{BE} where:

$$V_{BE} = \frac{nKT}{q} \times \ln\left(\frac{I_C}{I_S}\right) \quad (\text{eq. 1})$$

This technique, however, requires calibration to nullify the effect of the absolute value of V_{BE} , which varies from device to device.

The technique used in the ADM1023 is to measure the change in V_{BE} when the device is operated at two different collector currents.

This is given by:

$$\Delta V_{BE} = \frac{nKT}{q} \times \ln(N) \quad (\text{eq. 2})$$

where:

- K is Boltzmann's constant.
- q is the charge on the electron (1.6×10^{-19} Coulombs).
- T is the absolute temperature in Kelvins.
- N is the ratio of the two collector currents.
- n is the ideality factor of the thermal diode (TD).

To measure ΔV_{BE} , the sensor is switched between operating currents of I and NI. The resulting waveform is passed through a low-pass filter to remove noise, then to a chopper-stabilized amplifier that performs the functions of amplification and rectification of the waveform to produce a dc voltage proportional to ΔV_{BE} . This voltage is measured by the ADC, which gives a temperature output in binary format. To further reduce the effects of noise, digital filtering is performed by averaging the results of 16 measurement cycles. Signal conditioning and measurement of the internal temperature sensor are performed in a similar manner.

Figure 13 shows the input signal conditioning used to measure the output of an external temperature sensor. This figure shows the external sensor as a substrate PNP transistor, provided for temperature monitoring on some microprocessors, but it could equally well be a discrete transistor. If a discrete transistor is used, the collector is not grounded and should be connected to the base. To prevent ground noise from interfering with the measurement, the more negative terminal of the sensor is not referenced to ground but is biased above ground by an internal diode at the D- input. If the sensor is operating in a noisy environment, C1 may optionally be added as a noise filter. Its value is 1000 pF maximum. See the Layout Considerations section for more information on C1.

Sources of Errors on Thermal Transistors Measurement Method; The Effect of Ideality Factor (n)

The effects of ideality factor (n) and beta (β) of the temperature measured by a thermal transistor are described in this section. For a thermal transistor implemented on a submicron process, such as the substrate PNP used on a Pentium III processor, the temperature errors due to the combined effect of the ideality factor and beta are shown to be less than 3°C. Equation 2 is optimized for a substrate PNP transistor (used as a thermal diode) usually found on CPUs designed on submicron CMOS processes such as the Pentium III processor. There is a thermal diode on board each of these processors. The n in Equation 2 represents the ideality factor of this thermal diode. This ideality factor is a measure of the deviation of the thermal diode from ideal behavior.

According to Pentium III processor manufacturing specifications, measured values of n at 100°C are:

$$n_{MIN} = 1.0057 < n_{TYPICAL} = 1.008 < n_{MAX} = 1.0125 \quad (\text{eq. 3})$$

The ADM1023 takes this ideality factor into consideration when calculating temperature T_{TD} of the thermal diode. The

ADM1023 is optimized for $n_{TYPICAL} = 1.008$; any deviation on n from this typical value causes a temperature error that is calculated below for the n_{MIN} and n_{MAX} of a Pentium III processor at $T_{TD} = 100^\circ\text{C}$.

$$\begin{aligned} \Delta T_{MIN} &= \frac{1.0057 - 1.008}{1.008} \times (273.15 \text{ Kelvin} + 100^\circ\text{C}) = \\ &= - 0.85^\circ\text{C} \end{aligned} \quad (\text{eq. 4})$$

$$\begin{aligned} \Delta T_{MAX} &= \frac{1.0125 - 1.008}{1.008} \times (273.15 \text{ Kelvin} + 100^\circ\text{C}) = \\ &= + 1.67^\circ\text{C} \end{aligned}$$

Thus, the temperature error due to variation on n of the thermal diode for a Pentium III processor is about 2.5°C.

In general, this additional temperature error of the thermal diode measurement due to deviations on n from its typical value is given by:

$$\Delta T = \frac{n - 1.008}{1.008} \times (273.15 \text{ Kelvin} + T_{TD}) \quad (\text{eq. 5})$$

where T_{TD} is in °C.

Beta of Thermal Transistor (β)

In Figure 13, the thermal diode is a substrate PNP transistor where the emitter current is forced into the device. The derivation of Equation 2 assumed that the collector currents were scaled by N as the emitter currents were also scaled by N. Thus, this assumes that beta (β) of the transistor is constant for various collector currents. Figure 14 shows typical β variation vs. collector current for Pentium III processors at 100°C. The maximum β is 4.5 and varies less than 1% over the collector current range from 7 μA to 300 μA.

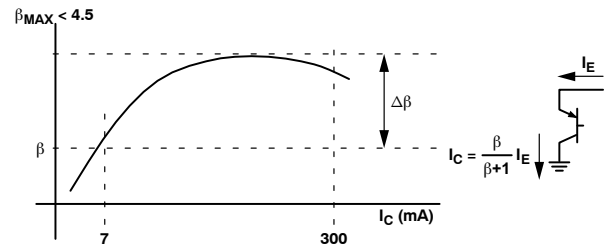

Figure 14. Variation of β with Collector Currents

Expressing the collector current in terms of the emitter current.

$$I_C = I_E [\beta / (\beta + 1)] \quad (\text{eq. 6})$$

where:

$$\begin{aligned} \beta(300 \mu\text{A}) &= \beta(7 \mu\text{A})(1 + \epsilon) \\ \epsilon &= \Delta \beta / \beta \text{ and } \beta = \beta(7 \mu\text{A}) \end{aligned} \quad (\text{eq. 7})$$

Rewriting the equation for ΔV_{BE} , to include the ideality factor, n, and beta, β yields:

$$\Delta V_{BE} = \frac{nKT}{q} \times \ln \left[\frac{(1 + \epsilon) \times (\beta + 1)}{(1 + \epsilon) \beta + 1} \times N \right] \quad (\text{eq. 8})$$

All β variations of less than 1% ($\epsilon < 0.01$) contribute to temperature errors of less than 0.4°C.

ADM1023

Temperature Data Format

One LSB of the ADC corresponds to 0.125°C, so the ADM1023 can measure from 0°C to 127.875°C. The temperature data format and extended temperature resolution are shown in Table 5 and Table 6.

**Table 5. TEMPERATURE DATA FORMAT
(LOCAL AND REMOTE TEMPERATURE HIGH BYTE)**

Temperature (°C) (Note 1)	Digital Output
0	0 000 0000
1	0 000 0001
10	0 000 1010
25	0 001 1001
50	0 011 0010
75	0 100 1011
100	0 110 0100
125	0 111 1101
127	0 111 1111

1. The ADM1023 differs from the ADM1021 in that the temperature resolution of the remote channel is improved from 1°C to 0.125°C, but it cannot measure temperatures below 0°C. If negative temperature measurement is required, the ADM1021 should be used.

The results of the local and remote temperature measurements are stored in the local and remote temperature value registers and are compared with limits programmed into the local and remote high and low limit registers.

**Table 6. EXTENDED TEMPERATURE RESOLUTION
(REMOTE TEMPERATURE LOW BYTE)**

Extended Resolution (°C)	Temperature Low Bits
0.000	0000 0000
0.125	0010 0000
0.250	0100 0000
0.375	0110 0000
0.500	1000 0000
0.625	1010 0000
0.750	1100 0000
0.875	1110 0000

Register Functions

The ADM1023 contains registers that are used to store the results of remote and local temperature measurements and high and low temperature limits, and to configure and control the device. A description of these registers follows, and further details are given in Table 7 to Table 11. Most of the registers for the ADM1023 are dual-port and have different addresses for read and write operations. Attempting to write to a read address or to read from a write address produces an invalid result. Register addresses above 0x14 are reserved for future use or factory test purposes and should not be written to.

Address Pointer Register

The address pointer register does not have, nor does it require, an address, because it is the register to which the first data byte of every write operation is automatically written. This data byte is an address pointer that sets up one of the other registers for the second byte of the write operation or for a subsequent read operation.

Value Registers

The ADM1023 has three registers to store the results of local and remote temperature measurements. These registers are written to by the ADC and can only be read over the SMBus.

The Offset Register

Two offset registers are provided at Address 0x11 and Address 0x12. These are provided so that the user may remove errors from the measured values of remote temperature. These errors may be introduced by clock noise and PCB track resistance. See Table 8 for an example of offset values.

The offset value is stored as an 11-bit, twos complement value in Register 0x11 (high byte) and Register 0x12 (low byte, left justified). The value of the offset is negative if the MSB of Register 0x11 is 1, and it is positive if the MSB of Register 0x11 is 0. This value is added to the remote temperature. These registers default to 0 at powerup and have no effect if nothing is written to them. The offset register can accept values from -128.875°C to +127.875°C. The ADM1023 detects overflow so the remote temperature value register does not wrap around +127°C or -128°C.

ADM1023

Table 7. LIST OF ADM1023 REGISTERS

Read Address (Hex)	Write Address (Hex)	Name	Power-on Default
Not Applicable	Not Applicable	Address Pointer	Undefined
00	Not Applicable	Local Temperature Value	1000 0000 (0x80) (-128°C)
01	Not Applicable	Remote Temperature Value High Byte	1000 0000 (0x80) (-128°C)
02	Not Applicable	Status	Undefined
03	09	Configuration	0000 0000 (0x00)
04	0A	Conversion Rate	0000 0010 (0x02)
05	0B	Local Temperature High Limit	0111 1111 (0x7F) (+127°C)
06	0C	Local Temperature Low Limit	1100 1001 (0xC9) (-55°C)
07	0D	Remote Temperature High Limit High Byte	0111 1111 (0x7F) (+127°C)
08	0E	Remote Temperature Low Limit High Byte	1100 1001 (0xC9) (-55°C)
Not Applicable	0F (Note 1)	One-shot	
10	Not Applicable	Remote Temperature Value Low Byte	0000 0000
11	11	Remote Temperature Offset High Byte	0000 0000
12	12	Remote Temperature Offset Low Byte	0000 0000
13	13	Remote Temperature High Limit Low Byte	0000 0000
14	14	Remote Temperature Low Limit Low Byte	0000 0000
19	Not Applicable	Reserved	0000 0000
20	21	Reserved	Undefined
FE	Not Applicable	Manufacturer Device ID	0100 0001 (0x41)
FF	Not Applicable	Die Revision Code	0011 xxxx (0x3x)

1. Writing to Address 0F causes the ADM1023 to perform a single measurement. It is not a data register as such; thus, it does not matter what data is written to it.

Table 8. OFFSET VALUES

Offset Registers			Remote Temperature	
0x11	0x12	Offset Value	With Offset	Without Offset
1111 1100	0000 0000	-4°C	14°C	18°C
1111 1111	0000 0000	-1°C	17°C	18°C
1111 1111	1110 0000	-0.125°C	17.875°C	18°C
0000 0000	0000 0000	0°C	18°C	18°C
0000 0000	0010 0000	+0.125°C	18.125°C	18°C
0000 0001	0000 0000	+1°C	19°C	18°C
0000 0100	0000 0000	+4°C	22°C	18°C

Status Register

Bit 7 of the status register (see Table 9) indicates that the ADC is busy converting when it is high. Bit 6 to Bit 3 are flags indicating the results of the limit comparisons.

If the local and/or remote temperature measurement is above the corresponding high temperature limit or below the corresponding low temperature limit, one or more of these flags will be set. Bit 2 is a flag that is set if the remote temperature sensor is open-circuit. These five flags are NOR'd together, so that if any of them are high, the ALERT interrupt latch is set, and the ALERT output goes low.

Reading the status register clears the five flag bits, provided the error conditions that caused the flags to be set have gone away. While a limit comparator is tripped due to a value register containing an out-of-limit measurement or the sensor is open-circuit, the corresponding flag bit cannot be reset. A flag bit can be reset only if the corresponding value register contains an in-limit measurement, or the sensor is good.

The ALERT interrupt latch is not reset by reading the status register, but it resets when the ALERT output has been serviced by the master reading the device address, provided the error condition has gone away and the status register flag bits have been reset.

Table 9. STATUS REGISTER BIT ASSIGNMENTS

Bit	Name	Function
7	BUSY	At 1 when ADC converting
6	LHIGH*	At 1 when local high temp limit tripped
5	LLOW*	At 1 when local low temp limit tripped
4	RHIGH*	At 1 when remote high temp limit tripped
3	RLOW*	At 1 when remote low temp limit tripped
2	OPEN*	At 1 when remote sensor open-circuit
1 to 0		Reserved

*These flags stay high until the status register is read or they are reset by POR.

Configuration Register

Two bits of the configuration register are used. If Bit 6 is 0, which is the power-on default, the device is in operating mode with the ADC converting (see Table 10). If Bit 6 is set to 1, the device is in standby mode and the ADC does not convert. Standby mode can also be selected by taking the $\overline{\text{STBY}}$ pin low. In standby mode, the values of remote and local temperature remain at the value they were before the part was placed in standby mode.

Bit 7 of the configuration register is used to mask the $\overline{\text{ALERT}}$ output. If Bit 7 is 0, which is the power-on default, the $\overline{\text{ALERT}}$ output is enabled. If Bit 7 is set to 1, the $\overline{\text{ALERT}}$ output is disabled.

Table 10. CONFIGURATION REGISTER BIT ASSIGNMENTS

Bit	Name	Function	Power-on Default
7	MASK1	0 = $\overline{\text{ALERT}}$ Enabled 1 = $\overline{\text{ALERT}}$ Masked	0
6	RUN/STOP	0 = Run 1 = Standby	0
5 to 0		Reserved	0

Conversion Rate Register

The lowest three bits of this register are used to program the conversion rate by dividing the ADC clock by 1, 2, 4, 8, 16, 32, 64, or 128, to give conversion times from 125 ms (Code 0x07) to 16 seconds (Code 0x00). This register can be written to and read back over the SMBus. The higher five bits of this register are unused and must be set to 0. Use of slower conversion times greatly reduces the device's power consumption, as shown in Table 11.

Table 11. CONVERSION RATE REGISTER CODE

Data	Conversion/Sec	Average Supply Current $\mu\text{A Typ at } V_{\text{CC}} = 3.3 \text{ V}$
0x00	0.0625	150
0x01	0.125	150
0x02	0.25	150
0x03	0.5	150
0x04	1	150
0x05	2	150
0x06	4	160
0x07	8	180
0x08 to 0xFF	Reserved	

Limit Registers

The ADM1023 has six limit registers to store local and remote, high and low temperature limits. These registers can be written to and read back over the SMBus. The high limit registers perform a > comparison, while the low limit registers perform a < comparison. For example, if the high limit register is programmed as a limit of 80°C, measuring 81°C results in an alarm condition. Even though the temperature range is 0 to 127°C, it is possible to program the limit register with negative values. This is for backward-compatibility with the ADM1021.

One-Shot Register

The one-shot register is used to initiate a single conversion and comparison cycle when the ADM1023 is in standby mode, after which the device returns to standby. This is not a data register as such, and it is the write operation that causes the one-shot conversion. The data written to this address is irrelevant and is not stored.

Serial Bus Interface

Control of the ADM1023 is carried out via the serial bus. The ADM1023 is connected to this bus as a slave device, under the control of a master device. Note that the SMBus SDA and SCLK pins are three-stated when the ADM1023 is powered down, and they do not pull down the SMBus.

Address Pins

In general, every SMBus device has a 7-bit device address (except for some devices that have extended, 10-bit addresses). When the master device sends a device address over the bus, the slave device with that address responds. The ADM1023 has two address pins, ADD0 and ADD1, to allow selection of the device address, so that several ADM1023s can be used on the same bus and to avoid conflict with other devices. Although only two address pins are provided, these pins are three-state and can be grounded, left unconnected, or tied to V_{DD} , so that a total of nine different addresses are possible, as shown in Table 12.

Note that the state of the address pins is sampled only at powerup, so changing them after powerup has no effect.

Table 12. DEVICE ADDRESSES (Note 1)

ADD0	ADD1	Device Address
0	0	0011 000
0	NC	0011 001
0	1	0011 010
NC	0	0101 001
NC	NC	0101 010
NC	1	0101 011
1	0	1001 100
1	NC	1001 101
1	1	1001 110

1. ADD0 and ADD1 are sampled at powerup only.

The serial bus protocol operates as follows:

1. The master initiates data transfer by establishing a start condition, defined as a high-to-low transition on the serial data line, SDATA, while the serial clock line, SCLK, remains high. This indicates that an address/data stream will follow. All slave peripherals connected to the serial bus respond to the start condition and shift in the next 8 bits. These bits consist of a 7-bit address (MSB first) plus an R/W bit, which determines the direction of the data transfer, that is, whether data is written to, or read from, the slave device. The peripheral whose address corresponds to the transmitted address responds by pulling the data

line low during the low period before the ninth clock pulse, known as the Acknowledge bit. All other devices on the bus remain idle while the selected device waits for data to be read from or written to it. If the R/W bit is 0, the master writes to the slave device. If the R/W bit is 1, the master reads from the slave device.

2. Data is sent over the serial bus in sequences of nine clock pulses, 8 bits of data followed by an Acknowledge bit from the slave device. Transitions on the data line must occur during the low period of the clock signal and remain stable during the high period, because a low-to-high transition when the clock is high may be interpreted as a stop signal. The number of data bytes that can be transmitted over the serial bus in a single read or write operation is limited only by what the master and slave devices can handle.
3. When all data bytes have been read or written, stop conditions are established. In write mode, the master pulls the data line high during the 10th clock pulse to assert a stop condition. In read mode, the master device overrides the Acknowledge bit by pulling the data line high during the low period before the ninth clock pulse. This is known as No Acknowledge. The master then takes the data line low during the low period before the 10th clock pulse, then high during the 10th clock pulse to assert a stop condition.

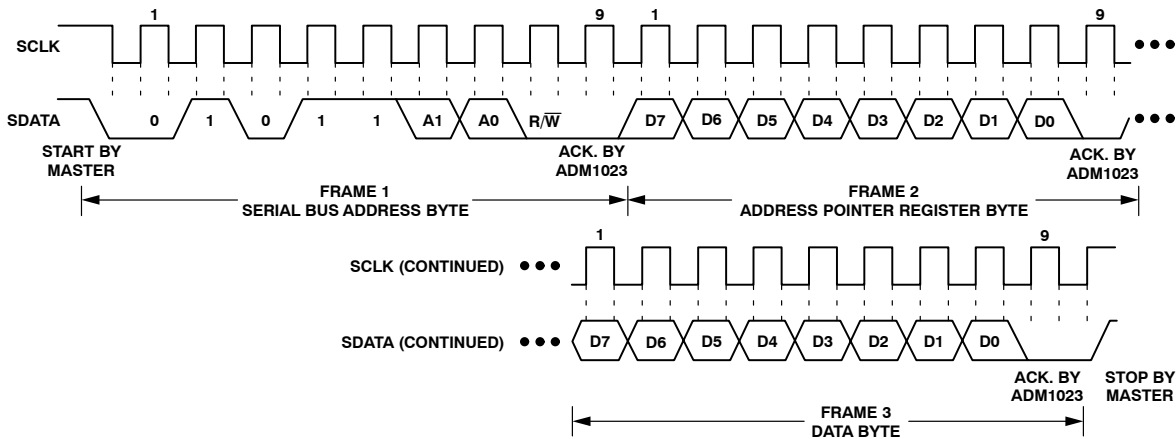

Figure 15. Writing a Register Address to the Address Pointer Register, then Writing Data to the Selected Register

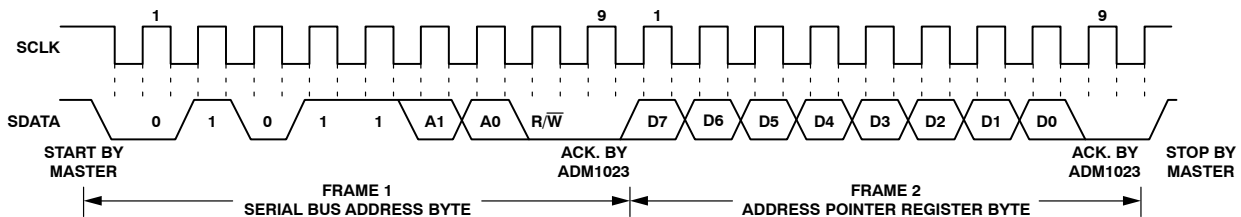

Figure 16. Writing to the Address Pointer Register Only

ADM1023

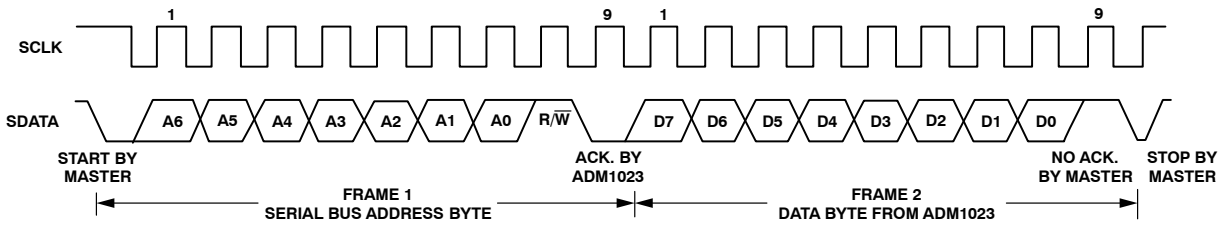

Figure 17. Reading Data from a Previously Selected Register

Any number of bytes of data may be transferred over the serial bus in one operation, but it is not possible to mix read and write in one operation because the type of operation is determined at the beginning and cannot subsequently be changed without starting a new operation.

For the ADM1023, write operations contain either one or two bytes, while read operations contain one byte and perform the following functions:

To write data to one of the device data registers or read data from it, the address pointer register must be set so that the correct data register is addressed. Data can then be written into that register or read from it. The first byte of a write operation always contains a valid address that is stored in the address pointer register. If data is to be written to the device, the write operation contains a second data byte that is written to the register selected by the address pointer register.

This is illustrated in Figure 15. The device address is sent over the bus followed by R/\overline{W} set to 0. This is followed by two data bytes. The first data byte is the address of the internal data register to be written to, which is stored in the address pointer register. The second data byte is the data to be written to the internal data register.

When reading data from a register, there are two possibilities:

1. If the ADM1023's address pointer register value is unknown or not the desired value, it is necessary to set it to the correct value before data can be read from the desired data register. This is done by performing a write to the ADM1023 as before, but only the data byte containing the register read address is sent, as data is not to be written to the register. This is shown in Figure 16. A read operation is then performed consisting of the serial bus address, R/\overline{W} bit set to 1, followed by the data byte read from the data register. This is shown in Figure 17.
2. If the address pointer register is known to be at the desired address already, data can be read from the corresponding data register without first writing to the address pointer register.

NOTES:

- It is possible to read a data byte from a data register without first writing to the address pointer register. However, it is not possible to write data to a register

without writing to the address pointer register even if the address pointer register is already at the correct value. This is because the first data byte of a write is always written to the address pointer register.

- Do not forget that ADM1023 registers have different addresses for read and write operations. The write address of a register must be written to the address pointer if data is to be written to that register, but it is not possible to read data from that address. The read address of a register must be written to the address pointer before data can be read from that register.

ALERT Output

The $\overline{\text{ALERT}}$ output goes low whenever an out-of-limit measurement is detected or if the remote temperature sensor is open-circuit. It is an open drain and requires a 10 k Ω pull-up to V_{DD} . Several $\overline{\text{ALERT}}$ outputs can be wire-AND'ed together, so that the common line goes low if one or more of the $\overline{\text{ALERT}}$ outputs goes low.

The $\overline{\text{ALERT}}$ output can be used as an interrupt signal to a processor, or it may be used as an $\overline{\text{SMBALERT}}$. Slave devices on the SMBus normally cannot signal to the master that they want to talk, but the $\overline{\text{SMBALERT}}$ function allows them to do so.

One or more $\overline{\text{ALERT}}$ outputs are connected to a common $\overline{\text{SMBALERT}}$ line connected to the master. When the $\overline{\text{SMBALERT}}$ line is pulled low by one of the devices, the procedure shown in Figure 18 occurs.

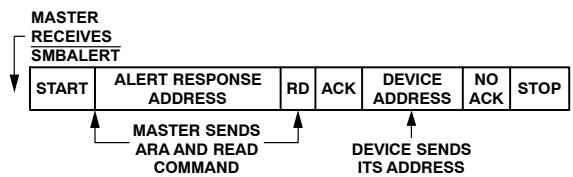

Figure 18. Use of $\overline{\text{SMBALERT}}$

$\overline{\text{SMBALERT}}$ Process

1. $\overline{\text{SMBALERT}}$ pulled low.
2. Master initiates a read operation and sends the alert response address (ARA = 0001 100). This is a general call address that must not be used as a specific device address.
3. The device whose $\overline{\text{ALERT}}$ output is low responds to the ARA and the master reads its device

address. The address of the device is now known, and it can be interrogated in the usual way.

4. If more than one device's ALERT output is low, the one with the lowest device address has priority, in accordance with normal SMBus arbitration.
5. Once the ADM1023 has responded to the ARA, it resets its ALERT output, provided that the error condition that caused the ALERT no longer exists. If the SMBALERT line remains low, the master sends ARA again, and so on until all devices whose ALERT outputs were low have responded.

Low Power Standby Modes

The ADM1023 can be put into a low power standby mode using hardware or software, that is, by taking the STBY input low or by setting Bit 6 of the configuration register. When STBY is high or Bit 6 is low, the ADM1023 operates normally. When STBY is pulled low or Bit 6 is high, the ADC is inhibited, and any conversion in progress is terminated without writing the result to the corresponding value register.

The SMBus is still enabled. Power consumption in the standby mode is reduced to less than 10 μA if there is no SMBus activity, or 100 μA if there are clock and data signals on the bus.

These two modes are similar but not identical. When STBY is low, conversions are completely inhibited. When Bit 6 is set, but STBY is high, a one-shot conversion of both channels can be initiated by writing any data value to the one-shot register (Address 0x0F).

Sensor Fault Detection

The ADM1023 has a fault detector at the D+ input that detects if the external sensor diode is open-circuit. This is a simple voltage comparator that trips if the voltage at D+ exceeds $V_{CC} - 1.0\text{ V}$ (typical). The output of this comparator is checked when a conversion is initiated and sets Bit 2 of the status register if a fault is detected.

If the remote sensor voltage falls below the normal measuring range, for example, due to the diode being short-circuited, the ADC outputs -128°C (1000 0000 000). Because the normal operating temperature range of the device extends only down to 0°C , this output code is never seen in normal operation and can be interpreted as a fault condition.

In this respect, the ADM1023 differs from, and improves upon, competitive devices that output 0 if the external sensor goes short-circuit. Unlike the ADM1023, these other devices can misinterpret a genuine 0°C measurement as a fault condition.

If the external diode channel is not being used and is shorted out, the resulting ALERT may be cleared by writing 0x80 (-128°C) to the low limit register.

Applications

Factors Affecting Accuracy, Remote Sensing Diode

The ADM1023 is designed to work with substrate transistors built into processors or with discrete transistors. Substrate transistors are generally PNP types with the collector connected to the substrate. Discrete types can be either PNP or NPN, connected as a diode (base-short to collector). If an NPN transistor is used, the collector and base are connected to D+ and the emitter to D-. If a PNP transistor is used, the collector and base are connected to D- and the emitter to D+.

The user has no choice with substrate transistors, but if a discrete transistor is used, the best accuracy is achieved by choosing devices according to the following criteria:

- Base Emitter Voltage Greater than 0.25 V at 6 μA , at the Highest Operating Temperature
- Base Emitter Voltage Less than 0.95 V at 100 μA , at the Lowest Operating Temperature
- Base Resistance Less than 100 Ω
- Small Variation in h_{fe} (Approximately 50 to 150), which Indicates Tight Control of V_{BE} Characteristics

Transistors such as 2N3904, 2N3906, or equivalents in SOT-23 packages are suitable devices to use.

Thermal Inertia and Self-heating

Accuracy depends on the temperature of the remote sensing diode and/or the internal temperature sensor being at the same temperature as that being measured, and a number of factors can affect this. Ideally, the sensor should be in good thermal contact with the part of the system being measured, such as the processor, for example. If it is not in good thermal contact, the thermal inertia caused by the mass of the sensor causes a lag in the response of the sensor to a temperature change. With the remote sensor, this should not be a problem, as it will be either a substrate transistor in the processor or a small package device, such as SOT-23, placed in close proximity to it.

The on-chip sensor, however, is often remote from the processor and monitors only the general ambient temperature around the package. The thermal time constant of the QSOP-16 package is about 10 seconds.

In practice, the package has electrical, and hence thermal, connection to the printed circuit board. Therefore, the temperature rise due to self-heating is negligible.

Layout Considerations

Digital boards can be electrically noisy environments, and the ADM1023 is measuring very small voltages from the remote sensor; therefore, care must be taken to minimize noise induced at the sensor inputs. The following precautions are needed:

ADM1023

- Place the ADM1023 as close as possible to the remote sensing diode. Provided that the worst noise sources, such as clock generators, data/address buses, and CRTs, are avoided, this distance can be 4 to 8 inches.
- Route the D+ and D- tracks close together, in parallel, with grounded guard tracks on each side. Provide a ground plane under the tracks if possible (see Figure 19).
- Use wide tracks to minimize inductance and reduce noise pickup. 10 mil track minimum width and spacing is recommended.



Figure 19. Arrangement of Signal Tracks

- Try to minimize the number of copper/solder joints, which can cause thermocouple effects. Where copper/solder joints are used, make sure that they are in both the D+ and D- path and at the same temperature. Thermocouple effects should not be a major problem as 1°C corresponds to about 240 μV , and thermocouple voltages are about 3 $\mu\text{V}/^\circ\text{C}$ of temperature difference. Unless there are two thermocouples with a big temperature differential between them, thermocouple voltages should be much less than 240 μV .
- Place a 0.1 μF bypass capacitor close to the V_{DD} pin and 1000 pF input filter capacitors across D+, D- close to the ADM1023.
- If the distance to the remote sensor is more than 8 inches, the use of twisted pair cable is recommended. This is effective up to approximately 6 to 12 feet.
- For longer distances (up to 100 feet), use shielded, twisted-pair cable such as Belden #8451 microphone cable. Connect the twisted pair to D+ and D-, and connect the shield to GND close to the ADM1023. Leave the remote end of the shield unconnected to avoid ground loops.

Because the measurement technique uses switched current sources, excessive cable and/or filter capacitance

can affect the measurement. When using long cables, the filter capacitor may be reduced or removed.

Cable resistance can also introduce errors. A 1 Ω series resistance introduces about 1°C error.

Application Circuits

Figure 20 shows a typical application circuit for the ADM1023, using a discrete sensor transistor connected via a shielded, twisted-pair cable. The pullups on SCLK, SDATA, and $\overline{\text{ALERT}}$ are required only if they are not already provided elsewhere in the system.

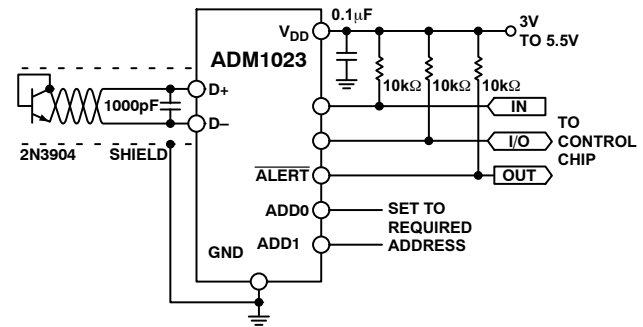

Figure 20. Typical Application Circuit

The SCLK and SDATA pins of the ADM1023 can be interfaced directly to the SMBus of an I/O chip. Figure 21 shows how the ADM1023 might be integrated into a system using this type of I/O controller.

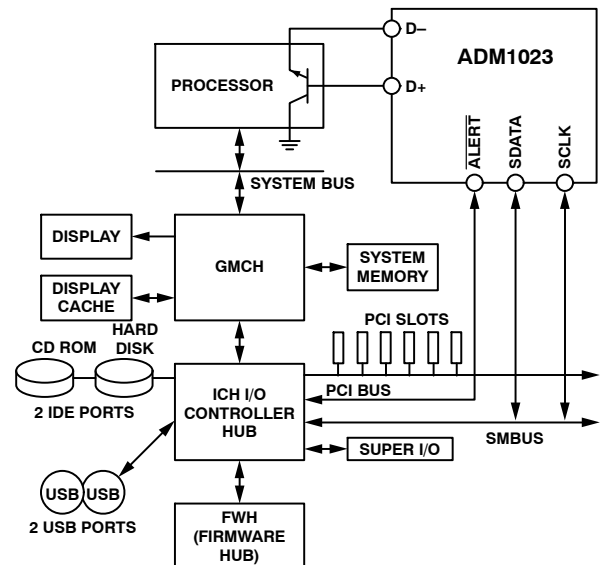

Figure 21. System Using ADM1023 and I/O Controller

Table 13. ORDERING INFORMATION

Device Number	Temperature Range	Package Type	Package Option	Shipping†
ADM1023ARQZ-REEL	0°C to +120°C	16-Lead QSOP	RQ-16	2,500 Tape & Reel

†For information on tape and reel specifications, including part orientation and tape sizes, please refer to our Tape and Reel Packaging Specifications Brochure, BRD8011/D.

*The "Z" suffix indicates Pb-Free part.

Protected by U.S. Patents 5,195,827; 5,867,012; 5,982,221; 6,097,239; 6,133,753; 6,169,442; other patents pending.
Pentium is a registered trademark of Intel Corporation.

MECHANICAL CASE OUTLINE PACKAGE DIMENSIONS

ON Semiconductor®

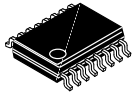

SCALE 2:1

QSOP16 CASE 492-01 ISSUE A

DATE 23 MAR 2011

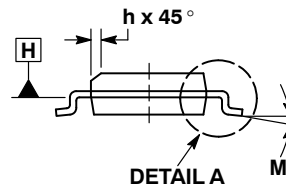
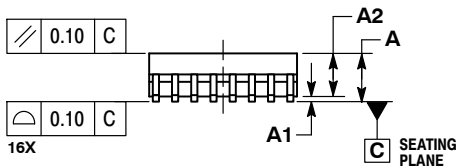
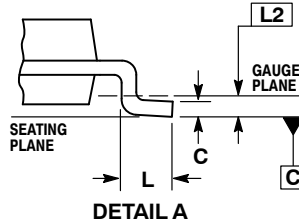
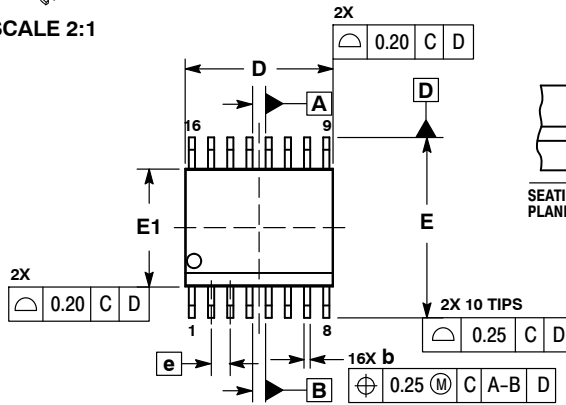

NOTES:

1. DIMENSIONING AND TOLERANCING PER ASME Y14.5M, 1994.
2. CONTROLLING DIMENSION: MILLIMETERS.
3. DIMENSION b DOES NOT INCLUDE DAMBAR PROTRUSION.
4. DIMENSION D DOES NOT INCLUDE MOLD FLASH, PROTRUSIONS, OR GATE BURRS. MOLD FLASH, PROTRUSIONS, OR GATE BURRS SHALL NOT EXCEED 0.005 PER SIDE. DIMENSION E1 DOES NOT INCLUDE INTERLEAD FLASH OR PROTRUSION. INTERLEAD FLASH OR PROTRUSION SHALL NOT EXCEED 0.005 PER SIDE. D AND E1 ARE DETERMINED AT DATUM H.
5. DATUMS A AND B ARE DETERMINED AT DATUM H.

DIM	INCHES		MILLIMETERS	
	MIN	MAX	MIN	MAX
A	0.053	0.069	1.35	1.75
A1	0.004	0.010	0.10	0.25
A2	0.049	----	1.24	----
b	0.008	0.012	0.20	0.30
c	0.007	0.010	0.19	0.25
D	0.193 BSC		4.89 BSC	
E	0.237 BSC		6.00 BSC	
E1	0.154 BSC		3.90 BSC	
e	0.025 BSC		0.635 BSC	
h	0.009	0.020	0.22	0.50
L	0.016	0.050	0.40	1.27
L2	0.010 BSC		0.25 BSC	
M	0°	8°	0°	8°

SOLDERING FOOTPRINT

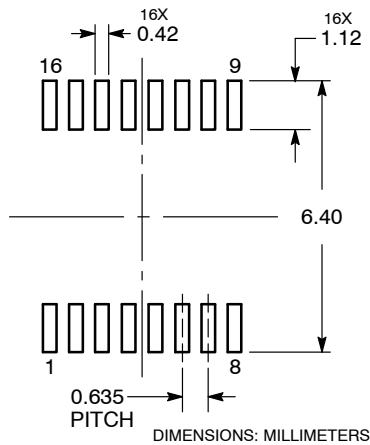

GENERIC MARKING DIAGRAM*

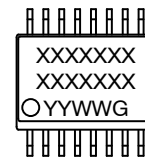

- XXXXXX = Specific Device Code
- YY = Year
- WW = Work Week
- G = Pb-Free Package

*This information is generic. Please refer to device data sheet for actual part marking. Pb-Free indicator, "G", may or not be present.

DOCUMENT NUMBER:	98AON04472D	Electronic versions are uncontrolled except when accessed directly from the Document Repository. Printed versions are uncontrolled except when stamped "CONTROLLED COPY" in red.
DESCRIPTION:	QSOP16	PAGE 1 OF 1

ON Semiconductor and are trademarks of Semiconductor Components Industries, LLC dba ON Semiconductor or its subsidiaries in the United States and/or other countries. ON Semiconductor reserves the right to make changes without further notice to any products herein. ON Semiconductor makes no warranty, representation or guarantee regarding the suitability of its products for any particular purpose, nor does ON Semiconductor assume any liability arising out of the application or use of any product or circuit, and specifically disclaims any and all liability, including without limitation special, consequential or incidental damages. ON Semiconductor does not convey any license under its patent rights nor the rights of others.

onsemi, **Onsemi**, and other names, marks, and brands are registered and/or common law trademarks of Semiconductor Components Industries, LLC dba "**onsemi**" or its affiliates and/or subsidiaries in the United States and/or other countries. **onsemi** owns the rights to a number of patents, trademarks, copyrights, trade secrets, and other intellectual property. A listing of **onsemi**'s product/patent coverage may be accessed at www.onsemi.com/site/pdf/Patent-Marking.pdf. **onsemi** reserves the right to make changes at any time to any products or information herein, without notice. The information herein is provided "as-is" and **onsemi** makes no warranty, representation or guarantee regarding the accuracy of the information, product features, availability, functionality, or suitability of its products for any particular purpose, nor does **onsemi** assume any liability arising out of the application or use of any product or circuit, and specifically disclaims any and all liability, including without limitation special, consequential or incidental damages. Buyer is responsible for its products and applications using **onsemi** products, including compliance with all laws, regulations and safety requirements or standards, regardless of any support or applications information provided by **onsemi**. "Typical" parameters which may be provided in **onsemi** data sheets and/or specifications can and do vary in different applications and actual performance may vary over time. All operating parameters, including "Typicals" must be validated for each customer application by customer's technical experts. **onsemi** does not convey any license under any of its intellectual property rights nor the rights of others. **onsemi** products are not designed, intended, or authorized for use as a critical component in life support systems or any FDA Class 3 medical devices or medical devices with a same or similar classification in a foreign jurisdiction or any devices intended for implantation in the human body. Should Buyer purchase or use **onsemi** products for any such unintended or unauthorized application, Buyer shall indemnify and hold **onsemi** and its officers, employees, subsidiaries, affiliates, and distributors harmless against all claims, costs, damages, and expenses, and reasonable attorney fees arising out of, directly or indirectly, any claim of personal injury or death associated with such unintended or unauthorized use, even if such claim alleges that **onsemi** was negligent regarding the design or manufacture of the part. **onsemi** is an Equal Opportunity/Affirmative Action Employer. This literature is subject to all applicable copyright laws and is not for resale in any manner.

PUBLICATION ORDERING INFORMATION

LITERATURE FULFILLMENT:

Email Requests to: orderlit@onsemi.com

onsemi Website: www.onsemi.com

TECHNICAL SUPPORT

North American Technical Support:

Voice Mail: 1 800-282-9855 Toll Free USA/Canada

Phone: 011 421 33 790 2910

Europe, Middle East and Africa Technical Support:

Phone: 00421 33 790 2910

For additional information, please contact your local Sales Representative