

Low Voltage 1-of-8 Decoder/Demultiplexer

74LVX138

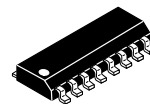

SOIC-16, 150 mils
CASE 751BG

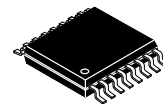

TSSOP 16
CASE 948AH

General Description

The LVX138 is a high-speed 1-of-8 decoder/demultiplexer. This device is ideally suited for high-speed bipolar memory chip select address decoding. The multiple input enables allow parallel expansion to a 1-of-24 decoder using just three LVX138 devices or a 1-of-32 decoder using four LVX138 devices and one inverter.

Features

- Input Voltage Level Translation from 5 V to 3 V
- Ideal for Low Power/Low Noise 3.3 V Applications
- Guaranteed Simultaneous Switching Noise Level and Dynamic Threshold Performance
- These Devices are Pb-Free and are RoHS Compliant

Logic Symbols

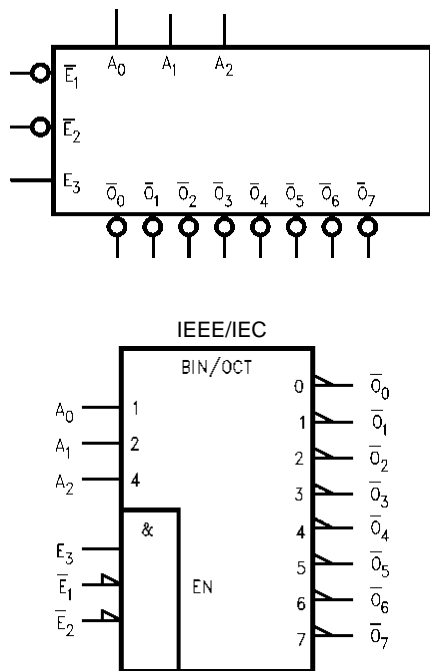
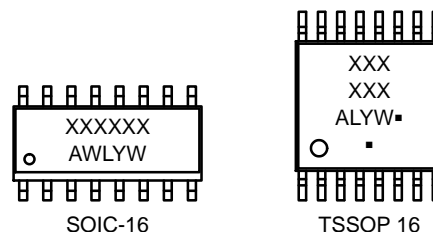

Figure 1. Logic Symbols

MARKING DIAGRAMS



SOIC-16
TSSOP 16

XXXXXX = Specific Device Code
A = Assembly Location
WL, L = Wafer Lot
Y = Year
WW, W = Work Week
G or ■ = Pb-Free Package

(Note: Microdot may be in either location)

CONNECTION DIAGRAM

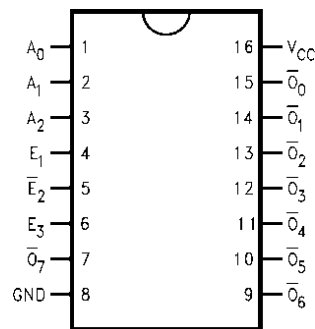

PIN DESCRIPTIONS

Pins	Function
A ₀ -A ₂	Address Inputs
E ₁ -E ₂	Enable Inputs
E ₃	Enable Input
O ₀ -O ₇	Outputs

ORDERING INFORMATION

See detailed ordering and shipping information in the package dimensions section on page 5 of this data sheet.

74LVX138

Functional Description

The LVX138 high-speed 1-of-8 decoder/demultiplexer accepts three binary weighted inputs (A_0, A_1, A_2) and, when enabled, provides eight mutually exclusive active-LOW outputs (\bar{O}_0 – \bar{O}_7). The LVX138 features three Enable inputs, two active-LOW (\bar{E}_1, \bar{E}_2) and one active-HIGH (E_3).

All outputs will be HIGH unless \bar{E}_1 and \bar{E}_2 are LOW and E_3 is HIGH.

The LVX138 can be used as an 8-output demultiplexer by using one of the active LOW Enable inputs as the data input and the other Enable inputs as strobes. The Enable inputs which are not used must be permanently tied to their appropriate active-HIGH or active-LOW state.

TRUTH TABLE

Inputs						Outputs							
\bar{E}_1	\bar{E}_2	E_3	A_0	A_1	A_2	\bar{O}_0	\bar{O}_1	\bar{O}_2	\bar{O}_3	\bar{O}_4	\bar{O}_5	\bar{O}_6	\bar{O}_7
H	X	X	X	X	X	H	H	H	H	H	H	H	H
X	H	X	X	X	X	H	H	H	H	H	H	H	H
X	X	L	X	X	X	H	H	H	H	H	H	H	H
L	L	H	L	L	L	L	H	H	H	H	H	H	H
L	L	H	H	L	L	H	L	H	H	H	H	H	H
L	L	H	L	H	L	H	H	L	H	H	H	H	H
L	L	H	H	H	L	H	H	H	L	H	H	H	H
L	L	H	L	L	H	H	H	H	H	L	H	H	H
L	L	H	H	L	H	H	H	H	H	H	L	H	H
L	L	H	L	H	H	H	H	H	H	H	H	L	H
L	L	H	H	H	H	H	H	H	H	H	H	H	L

H = HIGH Voltage Level
L = LOW Voltage Level
X = Immaterial

Logic Diagram

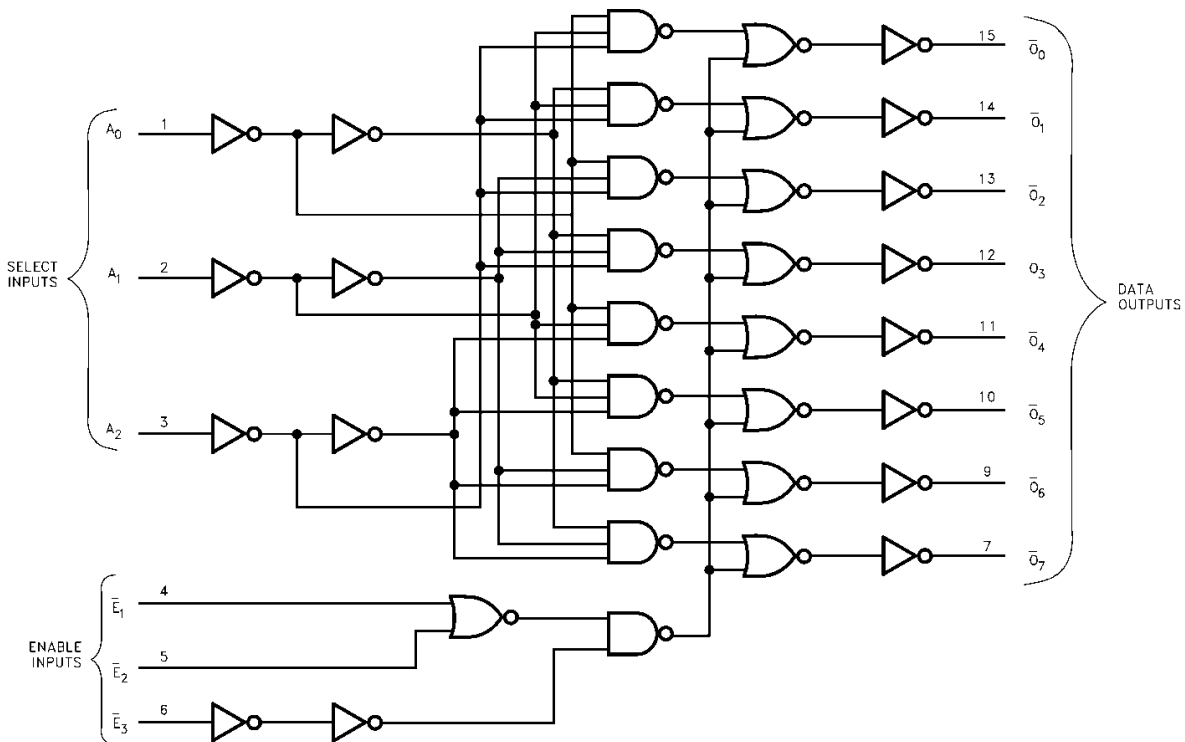

Please note that this diagram is provided only for the understanding of logic operations and should not be used to estimate propagation delays.

Figure 2. Logic Diagram

74LVX138

MAXIMUM RATINGS

Symbol	Parameter	Value	Unit	
V _{CC}	DC Supply Voltage	-0.5 to +6.5	V	
V _{IN}	DC Input Voltage	-0.5 to +6.5	V	
V _{OUT}	DC Output Voltage	-0.5 to V _{CC} + 0.5	V	
I _{IN}	DC Input Current, per Pin	±20	mA	
I _{OUT}	DC Output Current, per Pin	±25	mA	
I _{CC}	DC Supply Current, V _{CC} and GND Pins	±75	mA	
I _{IK}	Input Clamp Current	-20	mA	
I _{OK}	Output Clamp Current	±20	mA	
T _{STG}	Storage Temperature Range	-65 to +150	°C	
T _L	Lead Temperature, 1 mm from Case for 10 Seconds	260	°C	
T _J	Junction Temperature Under Bias	+150	°C	
θ _{JA}	Thermal Resistance (Note 1)	SOIC-16 TSSOP 16	126 159	°C/W
P _D	Power Dissipation in Still Air at 25 °C	SOIC-16 TSSOP 16	995 787	mW
MSL	Moisture Sensitivity	Level 1		
F _R	Flammability Rating	Oxygen Index: 28 to 34	UL 94 V-0 @ 0.125 in	
V _{ESD}	ESD Withstand Voltage (Note 2)	Human Body Model Charged Device Model	2000 N/A	V

Stresses exceeding those listed in the Maximum Ratings table may damage the device. If any of these limits are exceeded, device functionality should not be assumed, damage may occur and reliability may be affected.

1. Measured with minimum pad spacing on an FR4 board, using 76mm-by-114mm, 2-ounce copper trace no air flow per JESD51-7.
2. HBM tested to EIA / JESD22-A114-A. CDM tested to JESD22-C101-A. JEDEC recommends that ESD qualification to EIA/JESD22-A115A (Machine Model) be discontinued.

RECOMMENDED OPERATING CONDITIONS

Symbol	Parameter	Min	Max	Unit
V _{CC}	DC Supply Voltage	2.0	3.6	V
V _{in}	DC Input Voltage (Note 3)	0	5.5	V
V _{out}	DC Output Voltage (Note 3)	0	V _{CC}	V
T _A	Operating Temperature	-40	+85	°C
t _r , t _f	Input Rise and Fall Time	0	100	ns/V

Functional operation above the stresses listed in the Recommended Operating Ranges is not implied. Extended exposure to stresses beyond the Recommended Operating Ranges limits may affect device reliability.

3. Unused inputs must always be tied to an appropriate logic voltage level (e.g., either GND or V_{CC}). Unused outputs must be left open.

74LVX138

DC ELECTRICAL CHARACTERISTICS

Symbol	Parameter	Conditions	V _{CC} (V)	T _A = 25 °C			T _A = -40 to 85 °C		Unit	
				Min	Typ	Max	Min	Max		
V _{IH}	HIGH Level Input Voltage		2.0 3.0 3.6	1.5 2.0 2.4	– – –	– – –	1.5 2.0 2.4	– – –	V	
V _{IL}	LOW Level Input Voltage		2.0 3.0 3.6	– – –	– – –	0.5 0.8 0.8	– – –	0.5 0.8 0.8	V	
V _{OH}	HIGH Level Output Voltage	V _{IN} = V _{IL} or V _{IH}	I _{OH} = -50 μA I _{OH} = -50 μA I _{OH} = -4 mA	2.0 3.0 3.0	1.9 2.9 2.58	2.0 3.0 –	– – –	1.9 2.9 2.48	– – –	V
V _{OL}	LOW Level Output Voltage	V _{IN} = V _{IL} or V _{IH}	I _{OL} = 50 μA I _{OL} = 50 μA I _{OL} = 4 mA	2.0 3.0 3.0	– – –	0.0 0.0 –	0.1 0.1 0.36	– – –	0.1 0.1 0.44	V
I _{IN}	Input Leakage Current	V _{IN} = 5.5 V or GND		3.6	–	–	±0.1	–	±1.0	μA
I _{CC}	Quiescent Supply Current	V _{IN} = V _{CC} or GND		3.6	–	–	4.0	–	40.0	μA

NOISE CHARACTERISTICS (Note 4)

Symbol	Characteristic	C _L (pF)	V _{CC} (V)	T _A = 25 °C		Unit
				Typ	Limit	
V _{OLP}	Quiet Output Maximum Dynamic V _{OL}	50	3.3	0.3	0.5	V
V _{OLV}	Quiet Output Minimum Dynamic V _{OL}	50	3.3	-0.33	-0.5	V
V _{IHD}	Minimum HIGH Level Dynamic Input Voltage	50	3.3	–	2.0	V
V _{ILD}	Maximum LOW Level Dynamic Input Voltage	50	3.3	–	0.8	V

4. Input tr = tf = 3 ns

AC ELECTRICAL CHARACTERISTICS

Symbol	Parameter	C _L (pF)	V _{CC} (V)	T _A = 25 °C			T _A = -40 to 85 °C		Unit
				Min	Typ	Max	Min	Max	
t _{PLH} , t _{PHL}	Propagation Delay Time A _n to \bar{O}_n	15	2.7	–	7.1	13.8	1.0	16.5	ns
		50		–	9.6	17.3	1.0	20.0	
		15	3.3 ±0.3	–	5.5	8.8	1.0	10.5	
		50		–	8.0	12.3	1.0	14.0	
t _{PLH} , t _{PHL}	Propagation Delay Time \bar{E}_1 or \bar{E}_2 to \bar{O}_n	15	2.7	–	8.8	16.0	1.0	18.5	ns
		50		–	11.3	19.5	1.0	22.0	
		15	3.3 ±0.3	–	6.9	10.4	1.0	11.5	
		50		–	9.4	13.9	1.0	15.0	
t _{PLH} , t _{PHL}	Propagation Delay Time E ₃ to \bar{O}_n	15	2.7	–	8.7	16.3	1.0	19.5	ns
		50		–	11.2	19.8	1.0	23.0	
		15	3.3 ±0.3	–	6.8	10.6	1.0	12.5	
		50		–	9.3	14.1	1.0	16.0	
t _{OSSL} , t _{OSLH}	Output to Output Skew (Note 5)	50	2.7	–	–	1.5	–	1.5	ns
		50	3.3	–	–	1.5	–	1.5	

5. Parameter guaranteed by design. t_{OSLH} = |t_{PLHm} - t_{PLHn}|, t_{OSSL} = |t_{PHLm} - t_{PHLn}|

74LVX138

CAPACITANCE

Symbol	Parameter	T _A = 25 °C			T _A = -40 to 85 °C		Unit
		Min	Typ	Max	Min	Max	
C _{in}	Input Capacitance	–	4	10	–	10	pF
C _{PD}	Power Dissipation Capacitance (Note 6)	–	34	–	–	–	pF

6. CPD is defined as the value of the internal equivalent capacitance which is calculated from the operating current consumption without load. Average operating current can be obtained by the equation: $C_{PD} \times V_{CC} \times I_{IN} + I_{CC}$

ORDERING INFORMATION

Device	Marking	Package	Shipping [†]
74LVX138MX	LVX138G	SOIC-16 (Pb-Free)	2500 Tape & Reel
74LVX138MTCX	LVX 138	TSSOP 16 (Pb-Free)	2500 Tape & Reel

[†]For information on tape and reel specifications, including part orientation and tape sizes, please refer to our Tape and Reel Packaging Specifications Brochure, BRD8011/D.

SOIC-16, 150 mils
CASE 751BG
ISSUE O

DATE 19 DEC 2008

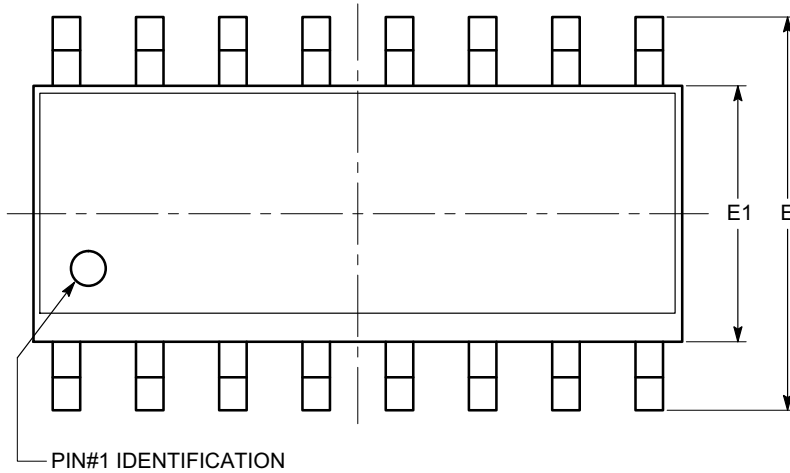

SYMBOL	MIN	NOM	MAX
A	1.35		1.75
A1	0.10		0.25
b	0.33		0.51
c	0.19		0.25
D	9.80	9.90	10.00
E	5.80	6.00	6.20
E1	3.80	3.90	4.00
e	1.27 BSC		
h	0.25		0.50
L	0.40		1.27
θ	0°		8°

TOP VIEW

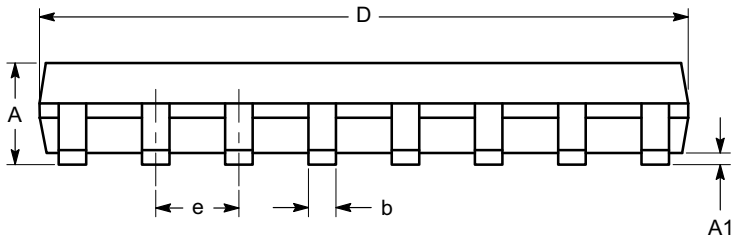

SIDE VIEW

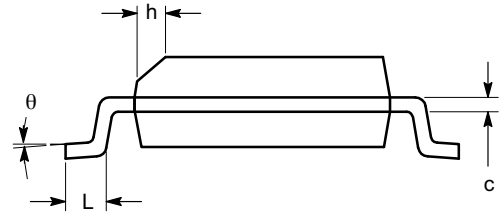

END VIEW

Notes:

- (1) All dimensions are in millimeters. Angles in degrees.
- (2) Complies with JEDEC MS-012.

DOCUMENT NUMBER:	98AON34275E	Electronic versions are uncontrolled except when accessed directly from the Document Repository. Printed versions are uncontrolled except when stamped "CONTROLLED COPY" in red.
DESCRIPTION:	SOIC-16, 150 mils	PAGE 1 OF 1

onsemi and ONSEMI are trademarks of Semiconductor Components Industries, LLC dba onsemi or its subsidiaries in the United States and/or other countries. onsemi reserves the right to make changes without further notice to any products herein. onsemi makes no warranty, representation or guarantee regarding the suitability of its products for any particular purpose, nor does onsemi assume any liability arising out of the application or use of any product or circuit, and specifically disclaims any and all liability, including without limitation special, consequential or incidental damages. onsemi does not convey any license under its patent rights nor the rights of others.

TSSOP 16
CASE 948AH
ISSUE O

DATE 19 SEP 2008

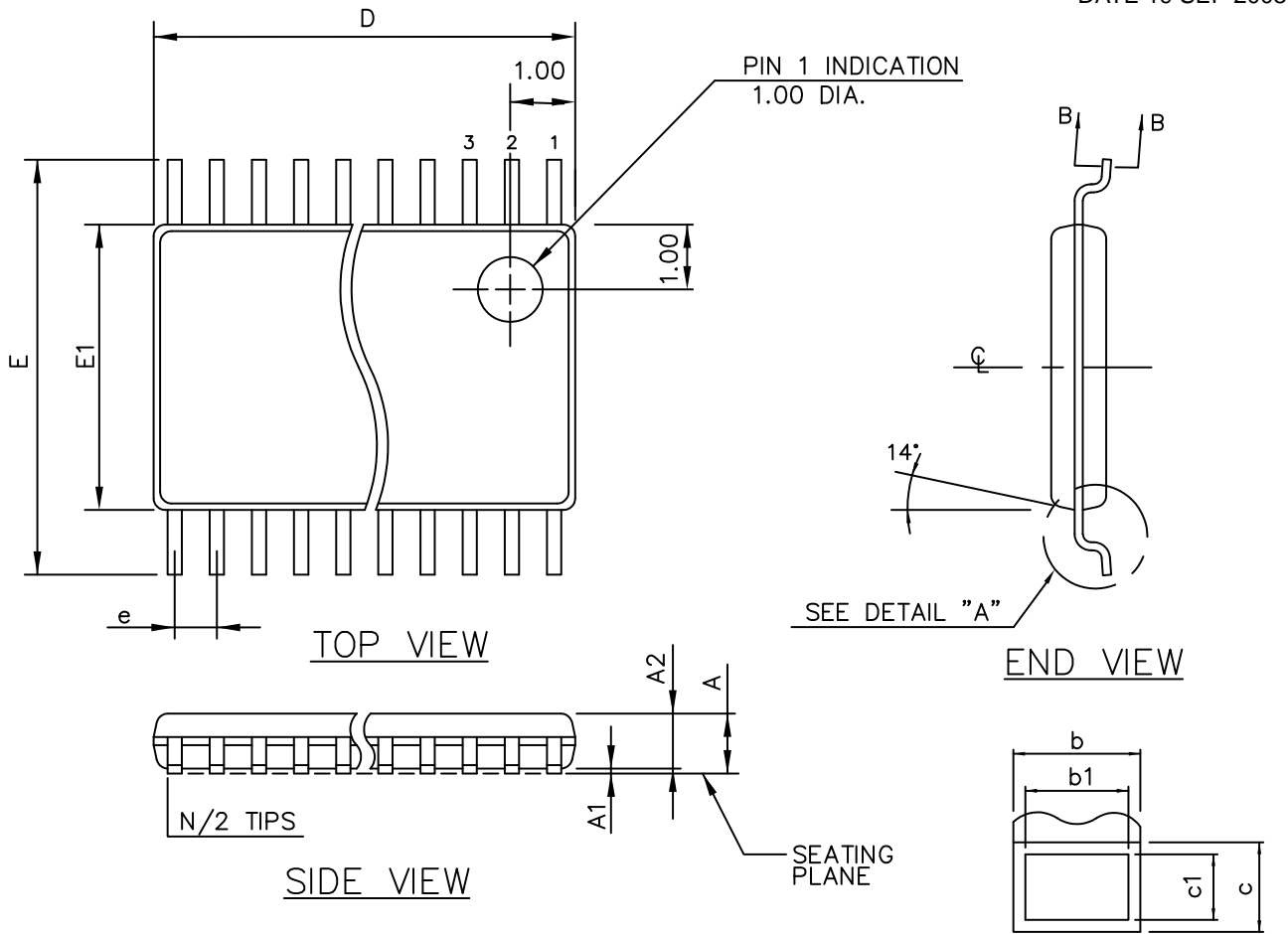

THIS TABLE FOR 0.65mm PITCH

Symbol	COMMON DIMENSIONS			NOTE VARIATIONS	D	N
	MIN.	NOM.	MAX.			
A	—	—	1.10	AA/AAT	3.00 BSC	8
A ₁	0.05	—	0.15	AB-1/ABT	5.00 BSC	14
A ₂	0.85	0.90	0.95	AB/ABT	5.00 BSC	16
b	0.19	—	0.30	AD/ADT	7.80 BSC	24
b1	0.19	0.22	0.25			
c	0.09	—	0.20			
c1	0.09	0.127	0.16			
D	SEE VARIATIONS					
E1	4.30	4.40	4.50			
e	0.65 BSC					
E	6.40 BSC					
L	0.50	0.60	0.70			
L1	1.00 REF					
N	SEE VARIATIONS					
X	0°	—	8°			

ALL DIMENSIONS IN MILLIMETERS

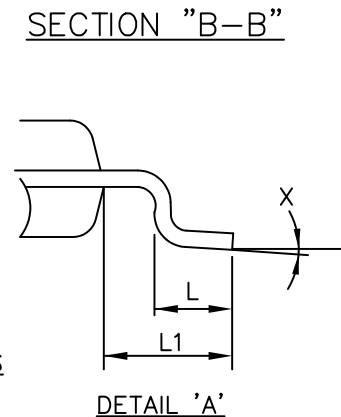

MOLD FLASH OR PROTRUSIONS SHALL NOT EXCEED 0.15mm ON D PER SIDE

DOCUMENT NUMBER:	98AON34923E	Electronic versions are uncontrolled except when accessed directly from the Document Repository. Printed versions are uncontrolled except when stamped "CONTROLLED COPY" in red.
DESCRIPTION:	TSSOP 16	PAGE 1 OF 1

onsemi and ONSEMI are trademarks of Semiconductor Components Industries, LLC dba onsemi or its subsidiaries in the United States and/or other countries. onsemi reserves the right to make changes without further notice to any products herein. onsemi makes no warranty, representation or guarantee regarding the suitability of its products for any particular purpose, nor does onsemi assume any liability arising out of the application or use of any product or circuit, and specifically disclaims any and all liability, including without limitation special, consequential or incidental damages. onsemi does not convey any license under its patent rights nor the rights of others.

onsemi, **Onsemi**, and other names, marks, and brands are registered and/or common law trademarks of Semiconductor Components Industries, LLC dba "**onsemi**" or its affiliates and/or subsidiaries in the United States and/or other countries. **onsemi** owns the rights to a number of patents, trademarks, copyrights, trade secrets, and other intellectual property. A listing of **onsemi**'s product/patent coverage may be accessed at www.onsemi.com/site/pdf/Patent-Marking.pdf. **onsemi** reserves the right to make changes at any time to any products or information herein, without notice. The information herein is provided "as-is" and **onsemi** makes no warranty, representation or guarantee regarding the accuracy of the information, product features, availability, functionality, or suitability of its products for any particular purpose, nor does **onsemi** assume any liability arising out of the application or use of any product or circuit, and specifically disclaims any and all liability, including without limitation special, consequential or incidental damages. Buyer is responsible for its products and applications using **onsemi** products, including compliance with all laws, regulations and safety requirements or standards, regardless of any support or applications information provided by **onsemi**. "Typical" parameters which may be provided in **onsemi** data sheets and/or specifications can and do vary in different applications and actual performance may vary over time. All operating parameters, including "Typicals" must be validated for each customer application by customer's technical experts. **onsemi** does not convey any license under any of its intellectual property rights nor the rights of others. **onsemi** products are not designed, intended, or authorized for use as a critical component in life support systems or any FDA Class 3 medical devices or medical devices with a same or similar classification in a foreign jurisdiction or any devices intended for implantation in the human body. Should Buyer purchase or use **onsemi** products for any such unintended or unauthorized application, Buyer shall indemnify and hold **onsemi** and its officers, employees, subsidiaries, affiliates, and distributors harmless against all claims, costs, damages, and expenses, and reasonable attorney fees arising out of, directly or indirectly, any claim of personal injury or death associated with such unintended or unauthorized use, even if such claim alleges that **onsemi** was negligent regarding the design or manufacture of the part. **onsemi** is an Equal Opportunity/Affirmative Action Employer. This literature is subject to all applicable copyright laws and is not for resale in any manner.

ADDITIONAL INFORMATION

TECHNICAL PUBLICATIONS:

Technical Library: www.onsemi.com/design/resources/technical-documentation
onsemi Website: www.onsemi.com

ONLINE SUPPORT: www.onsemi.com/support

For additional information, please contact your local Sales Representative at www.onsemi.com/support/sales