

Low Voltage 1-of-8 Decoder/Demultiplexer

With 5 V Tolerant Inputs

74LCX138

The LCX138 is a high-speed 1-of-8 decoder/demultiplexer. This device is ideally suited for high-speed memory chip select address decoding. The multiple input enables allow parallel expansion to a 1-of-24 decoder using just three LCX138 devices or a 1-of-32 decoder using four LCX138 devices and one inverter.

The 74LCX138 is fabricated with advanced CMOS technology to achieve high speed operation while maintaining CMOS low power dissipation.

Features

- 5 V Tolerant Inputs
- 1.65 V to 5.5 V V_{CC} Specifications Provided
- 6.0 ns t_{PD} Max ($V_{CC} = 3.3$ V), 10 μ A I_{CC} Max
- Power Down High Impedance Inputs and Outputs
- ± 24 mA Output Drive ($V_{CC} = 3.0$ V)
- Implements Patented Noise/EMI Reduction Circuitry
- Latch-up Performance Exceeds 100 mA
- ESD Performance: Human Body Model >2000 V
- These are Pb-Free Devices

MARKING DIAGRAMS

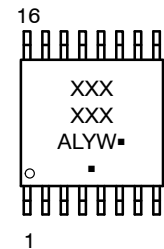
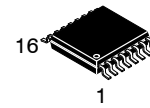
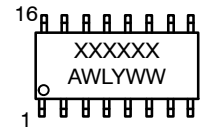
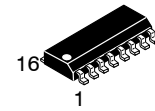
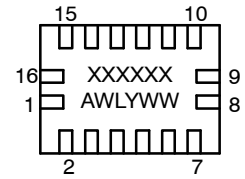
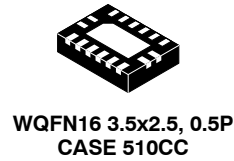

- A = Assembly Location
- WL, L = Wafer Lot
- Y = Year
- WW, W = Work Week
- G or ■ = Pb-Free Package

(Note: Microdot may be in either location)

ORDERING INFORMATION

See detailed ordering and shipping information in the package dimensions section on page 7 of this data sheet.

Connection Diagrams

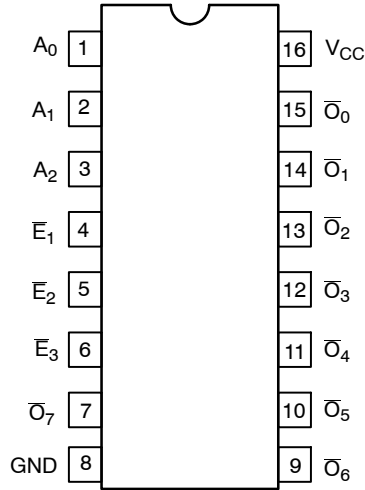

Figure 1. Pin Assignment for SOIC, SOP, and TSSOP

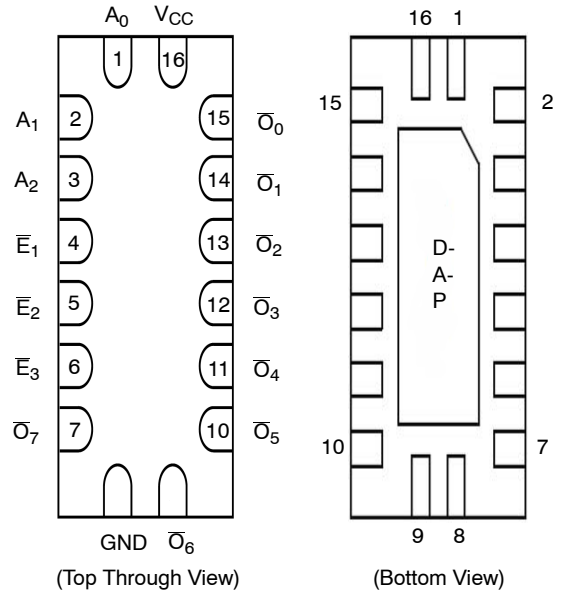

Figure 2. Pad Assignment for WQFN

PIN DESCRIPTIONS

Pin Names	Description
A ₀ -A ₂	Address Inputs
\bar{E}_1 - \bar{E}_2	Enable Inputs
E ₃	Enable Input
\bar{O}_0 - \bar{O}_7	Outputs
DAP	No Connect

NOTE: DAP (Die Attach Pad)

Functional Description

The LCX138 high-speed 1-of-8 decoder/demultiplexer accepts three binary weighted inputs (A₀, A₁, A₂) and, when enabled, provides eight mutually exclusive active-LOW outputs (O₀-O₇). The LCX138 features three Enable inputs, two active-LOW (E₁, E₂) and one active-HIGH (E₃). All outputs will be HIGH unless E₁ and E₂ are LOW and E₃ is HIGH. The LCX138 can be used as an 8-output demultiplexer by using one of the active LOW Enable inputs as the data input and the other Enable inputs as strobes. The Enable inputs which are not used must be permanently tied to their appropriate active-HIGH or active-LOW state.

TRUTH TABLE

Inputs						Outputs							
\bar{E}_1	\bar{E}_2	E ₃	A ₀	A ₁	A ₂	\bar{O}_0	\bar{O}_1	\bar{O}_2	\bar{O}_3	\bar{O}_4	\bar{O}_5	\bar{O}_6	\bar{O}_7
H	X	X	X	X	X	H	H	H	H	H	H	H	H
X	H	X	X	X	X	H	H	H	H	H	H	H	H
X	X	L	X	X	X	H	H	H	H	H	H	H	H
L	L	H	L	L	L	L	H	H	H	H	H	H	H
L	L	H	H	L	L	H	L	H	H	H	H	H	H
L	L	H	L	H	L	H	H	L	H	H	H	H	H
L	L	H	H	H	L	H	H	H	L	H	H	H	H
L	L	H	L	L	H	H	H	H	H	L	H	H	H
L	L	H	H	L	H	H	H	H	H	H	L	H	H
L	L	H	L	H	H	H	H	H	H	H	H	L	H
L	L	H	H	H	H	H	H	H	H	H	H	H	L

H = HIGH Voltage Level
 L = LOW Voltage Level
 X = Immaterial

74LCX138

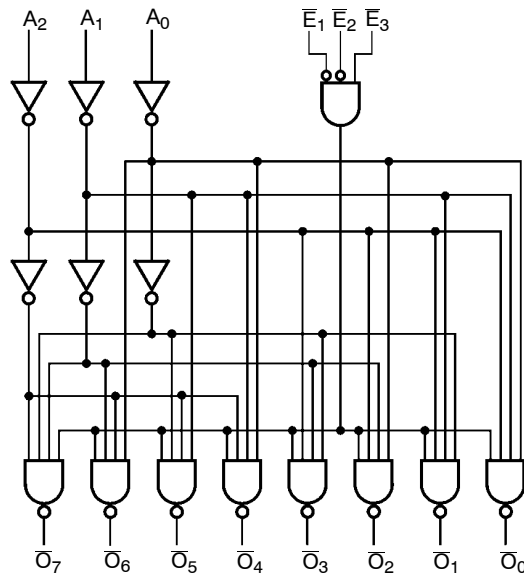

Figure 3. Logic Diagram

NOTE: Please note that this diagram is provided only for the understanding of logic operations and should not be used to estimate propagation delays.

ABSOLUTE MAXIMUM RATINGS

Symbol	Parameter	Value	Unit	
V_{CC}	DC Supply Voltage	-0.5 to +6.5	V	
V_I	DC Input Voltage (Note 1)	-0.5 to +6.5	V	
V_O	DC Output Voltage (Note 1)	Active-Mode (High or Low State) Tri-State Mode Power-Down Mode ($V_{CC} = 0$ V)	-0.5 to $V_{CC} + 0.5$ -0.5 to +6.5 -0.5 to +6.5	V
I_{IK}	DC Input Diode Current	$V_I < GND$	-50	mA
I_{OK}	DC Output Diode Current	$V_O < GND$	-50	mA
I_O	DC Output Source/Sink Current		± 50	mA
I_{CC} or I_{GND}	DC Supply Current per Supply Pin or Ground Pin		± 100	mA
T_{STG}	Storage Temperature Range		-65 to +150	$^{\circ}C$
T_L	Lead Temperature, 1 mm from Case for 10 secs		260	$^{\circ}C$
T_J	Junction Temperature Under Bias		+150	$^{\circ}C$
θ_{JA}	Thermal Resistance (Note 1)	SOIC-16 WQFN-16 TSSOP-16	126 114 159	$^{\circ}C/W$
P_D	Power Dissipation in Still Air at 125 $^{\circ}C$	SOIC-16 WQFN-16 TSSOP-16	995 1094 787	mW
MSL	Moisture Sensitivity		Level 1	-
F_R	Flammability Rating	Oxygen Index: 28 to 34	UL 94 V-0 @ 0.125 in	-
V_{ESD}	ESD Withstand Voltage (Note 3)	Human Body Model Charged Device Model	2000 N/A	V

Stresses exceeding those listed in the Maximum Ratings table may damage the device. If any of these limits are exceeded, device functionality should not be assumed, damage may occur and reliability may be affected.

- I_O absolute maximum rating must be observed.
- Measured with minimum pad spacing on an FR4 board, using 76 mm-by-114 mm, 2-ounce copper trace no air flow per JESD51-7.
- HBM tested to EIA / JESD22-A114-A. CDM tested to JESD22-C101-A. JEDEC recommends that ESD qualification to EIA/JESD22-A115A (Machine Model) be discontinued.

74LCX138

RECOMMENDED OPERATING CONDITIONS

Symbol	Parameter	Min	Typ	Max	Unit	
V _{CC}	Supply Voltage	Operating	3.3	5.5	V	
		Data Retention Only	1.5	3.3		
V _I	Digital Input Voltage	0	–	5.5	V	
V _O	Output Voltage	Active Mode (High or Low State)	0	–	V _{CC}	
		Tri-State Mode	0	–	5.5	
		Power Down Mode (V _{CC} = 0 V)	0	–	5.5	
T _A	Operating Free-Air Temperature	–40	–	+125	°C	
t _r , t _f	Input Rise or Fall Rate	V _{CC} = 1.65 V to 1.95 V	0	–	20	nS/V
		V _{CC} = 2.3 V to 2.7 V	0	–	20	
		V _{IN} from 0.8 V to 2.0 V, V _{CC} = 3.0 V	0	–	10	
		V _{CC} = 4.5 V to 5.5 V	0	–	5	
			0	–		

Functional operation above the stresses listed in the Recommended Operating Ranges is not implied. Extended exposure to stresses beyond the Recommended Operating Ranges limits may affect device reliability.

4. Unused inputs must always be tied to an appropriate logic voltage level (e.g., either GND or V_{CC}). Unused outputs must be left open.

DC ELECTRICAL CHARACTERISTICS

Symbol	Parameter	Conditions	V _{CC} (V)	T _A = –40°C to +85°C		T _A = –40°C to +125°C		Unit
				Min	Max	Min	Max	
V _{IH}	HIGH Level Input Voltage		1.65 – 1.95	0.65 x V _{CC}	–	0.65 x V _{CC}	–	V
			2.3 – 2.7	1.7	–	1.7	–	
			3.0 – 3.6	2.0	–	2.0	–	
			4.5 – 5.5	0.70 x V _{CC}	–	0.70 x V _{CC}	–	
V _{IL}	LOW Level Input Voltage		1.65 – 1.95	–	0.35 x V _{CC}	–	0.35 x V _{CC}	V
			2.3 – 2.7	–	0.7	–	0.7	
			3.0 – 3.6	–	0.8	–	0.8	
			4.5 – 5.5	–	0.30 x V _{CC}	–	0.30 x V _{CC}	
V _{OH}	High-Level Output Voltage	V _I = V _{IH} or V _{IL} I _{OH} = –100 μA I _{OH} = –4 mA I _{OH} = –8 mA I _{OH} = –12 mA I _{OH} = –16 mA I _{OH} = –24 mA I _{OH} = –32 mA	1.65 – 5.5	V _{CC} – 0.1	–	V _{CC} – 0.1	–	V
			1.65	1.29	–	1.29	–	
			2.3	1.8	–	1.8	–	
			2.7	2.2	–	2.2	–	
			3.0	2.4	–	2.4	–	
			3.0	2.2	–	2.2	–	
			4.5	3.7	–	3.7	–	
V _{OL}	Low-Level Output Voltage	V _I = V _{IH} or V _{IL} I _{OL} = 100 μA I _{OL} = 4 mA I _{OL} = 8 mA I _{OL} = 12 mA I _{OL} = 16 mA I _{OL} = 24 mA I _{OL} = 32 mA	1.65 – 5.5	–	0.1	–	0.1	V
			1.65	–	0.24	–	0.24	
			2.3	–	0.3	–	0.3	
			2.7	–	0.4	–	0.4	
			3.0	–	0.4	–	0.4	
			3.0	–	0.55	–	0.55	
			4.5	–	0.6	–	0.6	
I _I	Input Leakage Current	V _I = 0 to 5.5 V	1.65 – 5.5	–	±5.0	–	±5.0	μA
I _{OFF}	Power Off Leakage Current	V _I = 5.5 V or V _O = 5.5 V	0	–	10	–	10	μA
I _{CC}	Quiescent Supply Current	V _I = 5.5 V or GND	1.65 – 5.5	–	10	–	10	μA
ΔI _{CC}	Increase in I _{CC} per Input	V _{IH} = V _{CC} – 0.6 V	2.3 – 3.6	–	500	–	500	μA

Product parametric performance is indicated in the Electrical Characteristics for the listed test conditions, unless otherwise noted. Product performance may not be indicated by the Electrical Characteristics if operated under different conditions.

74LCX138

AC ELECTRICAL CHARACTERISTICS

Symbol	Parameter	Test Condition	V _{CC} (V)	T _A = -40°C to +85°C		T _A = -40°C to +125°C		Unit
				Min	Max	Min	Max	
t _{PLH} , t _{PHL}	Propagation Delay, A _n to $\overline{O_n}$	See Figures 4 and 5	1.65 to 1.95	-	11.5	-	11.5	ns
			2.3 to 2.7	-	7.2	-	7.2	
			2.7	-	7.0	-	7.0	
			3.0 to 3.6	-	6.0	-	6.0	
			4.5 to 5.5	-	5.0	-	5.0	
t _{PLH} , t _{PHL}	Propagation Delay, E1, E2 to $\overline{O_n}$	See Figures 4 and 5	1.65 to 1.95	-	12.0	-	12.0	ns
			2.3 to 2.7	-	8.4	-	8.4	
			2.7	-	7.5	-	7.5	
			3.0 to 3.6	-	6.5	-	6.5	
			4.5 to 5.5	-	5.5	-	5.5	
t _{PLH} , t _{PHL}	Propagation Delay, E3 to $\overline{O_n}$	See Figures 4 and 5	1.65 to 1.95	-	11.5	-	11.5	ns
			2.3 to 2.7	-	7.2	-	7.2	
			2.7	-	7.0	-	7.0	
			3.0 to 3.6	-	6.0	-	6.0	
			4.5 to 5.5	-	5.0	-	5.0	
t _{OSSL} , t _{OSLH}	Output to Output Skew (Note 5)		1.65 to 1.95	-	-	-	-	ns
			2.3 to 2.7	-	-	-	-	
			2.7	-	-	-	-	
			3.0 to 3.6	-	1.0	-	1.0	
			4.5 to 5.5	-	-	-	-	

Product parametric performance is indicated in the Electrical Characteristics for the listed test conditions, unless otherwise noted. Product performance may not be indicated by the Electrical Characteristics if operated under different conditions.

5. Skew is defined as the absolute value of the difference between the actual propagation delay for any two separate outputs of the same device. The specification applies to any outputs switching in the same direction, either HIGH-to-LOW (t_{OSSL}) or LOW-to-HIGH (t_{OSLH}). Parameter guaranteed by design.

DYNAMIC SWITCHING CHARACTERISTICS

Symbol	Parameter	Conditions	V _{CC} (V)	T _A = 25°C	Unit
				Typical	
V _{OLP}	Quiet Output Dynamic Peak V _{OL}	C _L = 50 pF, V _{IH} = 3.3 V, V _{IL} = 0 V	3.3	0.8	V
		C _L = 30 pF, V _{IH} = 2.5 V, V _{IL} = 0 V	2.5	0.6	
V _{OLV}	Quiet Output Dynamic Valley V _{OL}	C _L = 50 pF, V _{IH} = 3.3 V, V _{IL} = 0 V	3.3	-0.8	V
		C _L = 30 pF, V _{IH} = 2.5 V, V _{IL} = 0 V	2.5	-0.6	

CAPACITANCE

Symbol	Parameter	Condition	Typical	Units
C _{IN}	Input Capacitance	V _{CC} = Open, V _I = 0 V or V _{CC}	7.0	pF
C _{OUT}	Output Capacitance	V _{CC} = 3.3 V, V _I = 0 V or V _{CC}	8.0	pF
C _{PD}	Power Dissipation Capacitance	V _{CC} = 3.3 V, V _I = 0 V or V _{CC} , f = 10 MHz	25.0	pF

74LCX138

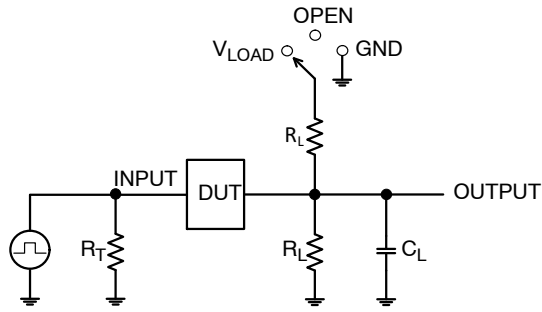

C_L includes probe and jig capacitance
 R_T is Z_{OUT} of pulse generator (typically 50 Ω)
 $f = 1$ MHz

Test	Switch Position
t_{PLH} / t_{PHL}	Open
t_{PLZ} / t_{PZL}	V_{LOAD}
t_{PHZ} / t_{PZH}	GND

Figure 4. Test Circuit

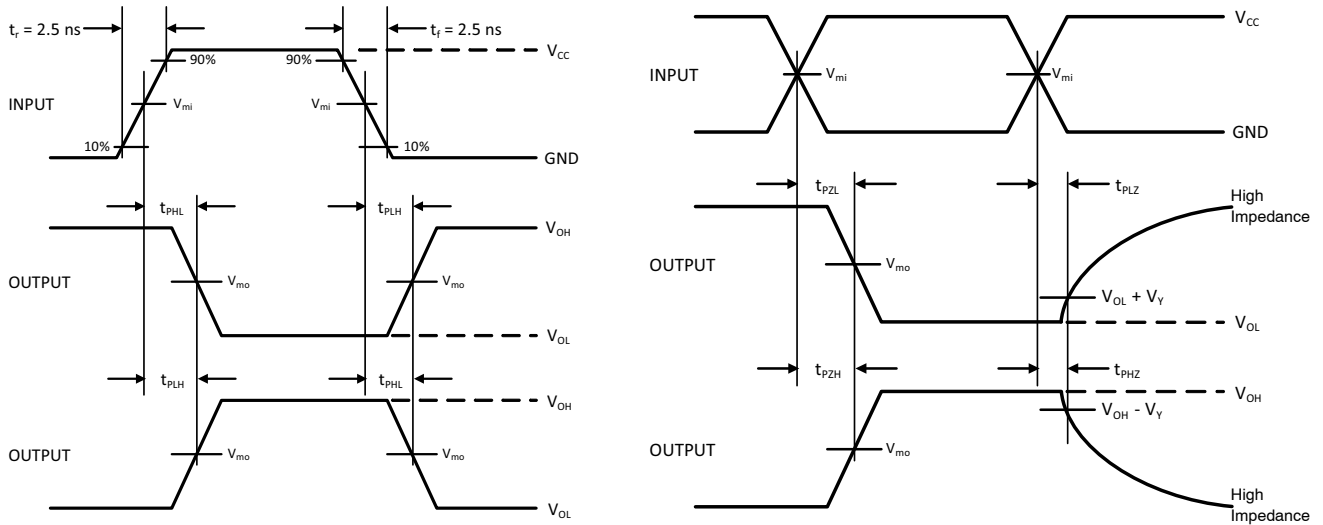

V_{CC}, V	R_L, Ω	C_L, pF	V_{LOAD}	V_m, V	V_Y, V
1.65 to 1.95	500	30	$2 \times V_{CC}$	$V_{CC}/2$	0.15
2.3 to 2.7	500	30	$2 \times V_{CC}$	$V_{CC}/2$	0.15
2.7	500	50	6 V	1.5	0.3
3.0 to 3.6	500	50	6 V	1.5	0.3
4.5 to 5.5	500	50	$2 \times V_{CC}$	$V_{CC}/2$	0.3

Figure 5. Switching Waveforms

74LCX138

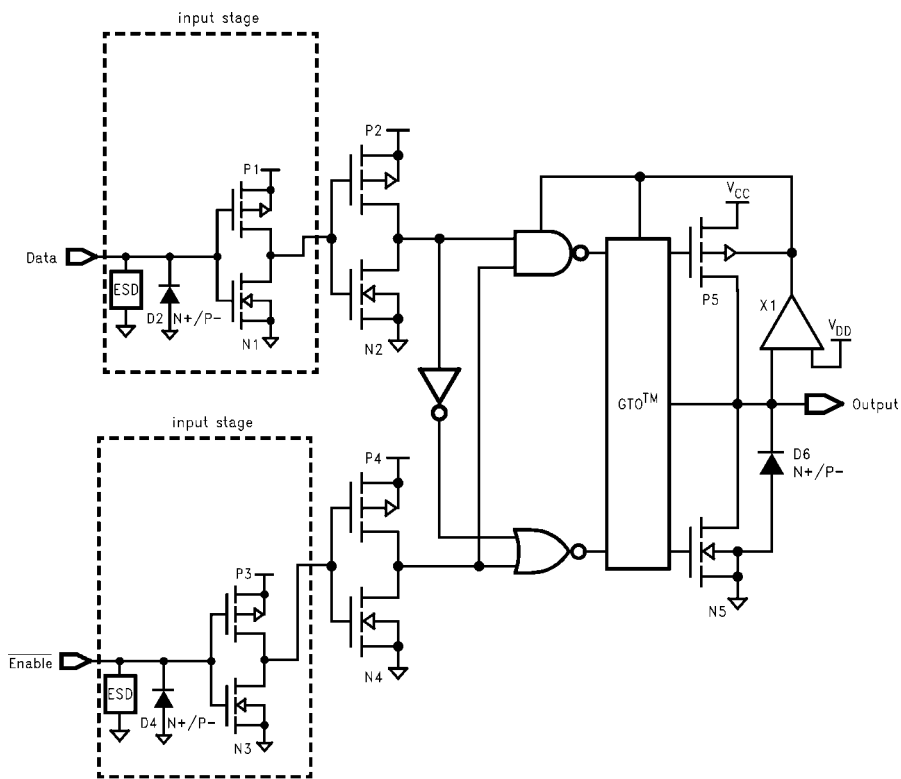

Figure 6. Schematic Diagram (Generic for LCX Family)

ORDERING INFORMATION

Device	Marking	Package	Shipping†
74LCX138BQX	LCX138	WQFN-16 (Pb-Free)	3000 Units / Tape & Reel
74LCX138MX	LCX138	SOIC-16 (Pb-Free)	2500 Units / Tape & Reel
74LCX138MTCX	LCX 138	TSSOP-16 (Pb-Free)	2500 Units / Tape & Reel

†For information on tape and reel specifications, including part orientation and tape sizes, please refer to our Tape and Reel Packaging Specifications Brochure, [BRD8011/D](#).

SOIC-16, 150 mils
CASE 751BG
ISSUE O

DATE 19 DEC 2008

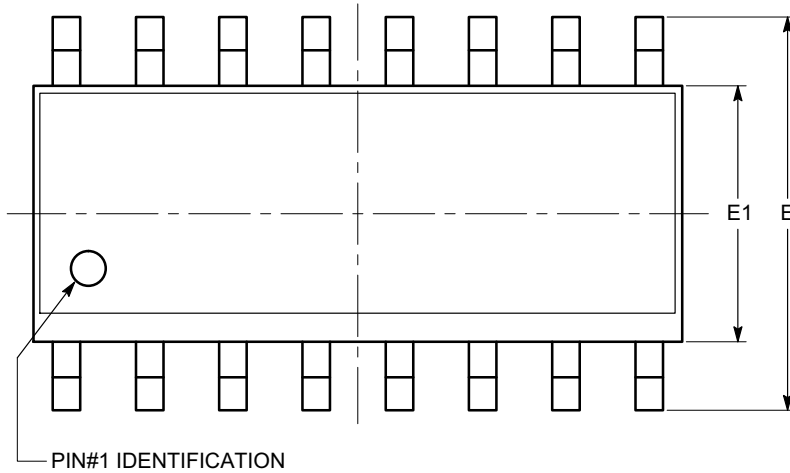

SYMBOL	MIN	NOM	MAX
A	1.35		1.75
A1	0.10		0.25
b	0.33		0.51
c	0.19		0.25
D	9.80	9.90	10.00
E	5.80	6.00	6.20
E1	3.80	3.90	4.00
e	1.27 BSC		
h	0.25		0.50
L	0.40		1.27
θ	0°		8°

TOP VIEW

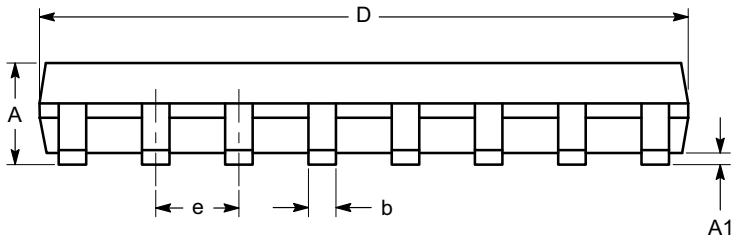

SIDE VIEW

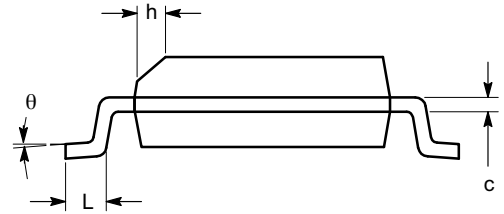

END VIEW

Notes:

- (1) All dimensions are in millimeters. Angles in degrees.
- (2) Complies with JEDEC MS-012.

DOCUMENT NUMBER:	98AON34275E	Electronic versions are uncontrolled except when accessed directly from the Document Repository. Printed versions are uncontrolled except when stamped "CONTROLLED COPY" in red.
DESCRIPTION:	SOIC-16, 150 mils	PAGE 1 OF 1

onsemi and ONSEMI are trademarks of Semiconductor Components Industries, LLC dba onsemi or its subsidiaries in the United States and/or other countries. onsemi reserves the right to make changes without further notice to any products herein. onsemi makes no warranty, representation or guarantee regarding the suitability of its products for any particular purpose, nor does onsemi assume any liability arising out of the application or use of any product or circuit, and specifically disclaims any and all liability, including without limitation special, consequential or incidental damages. onsemi does not convey any license under its patent rights nor the rights of others.

TSSOP 16
CASE 948AH
ISSUE O

DATE 19 SEP 2008

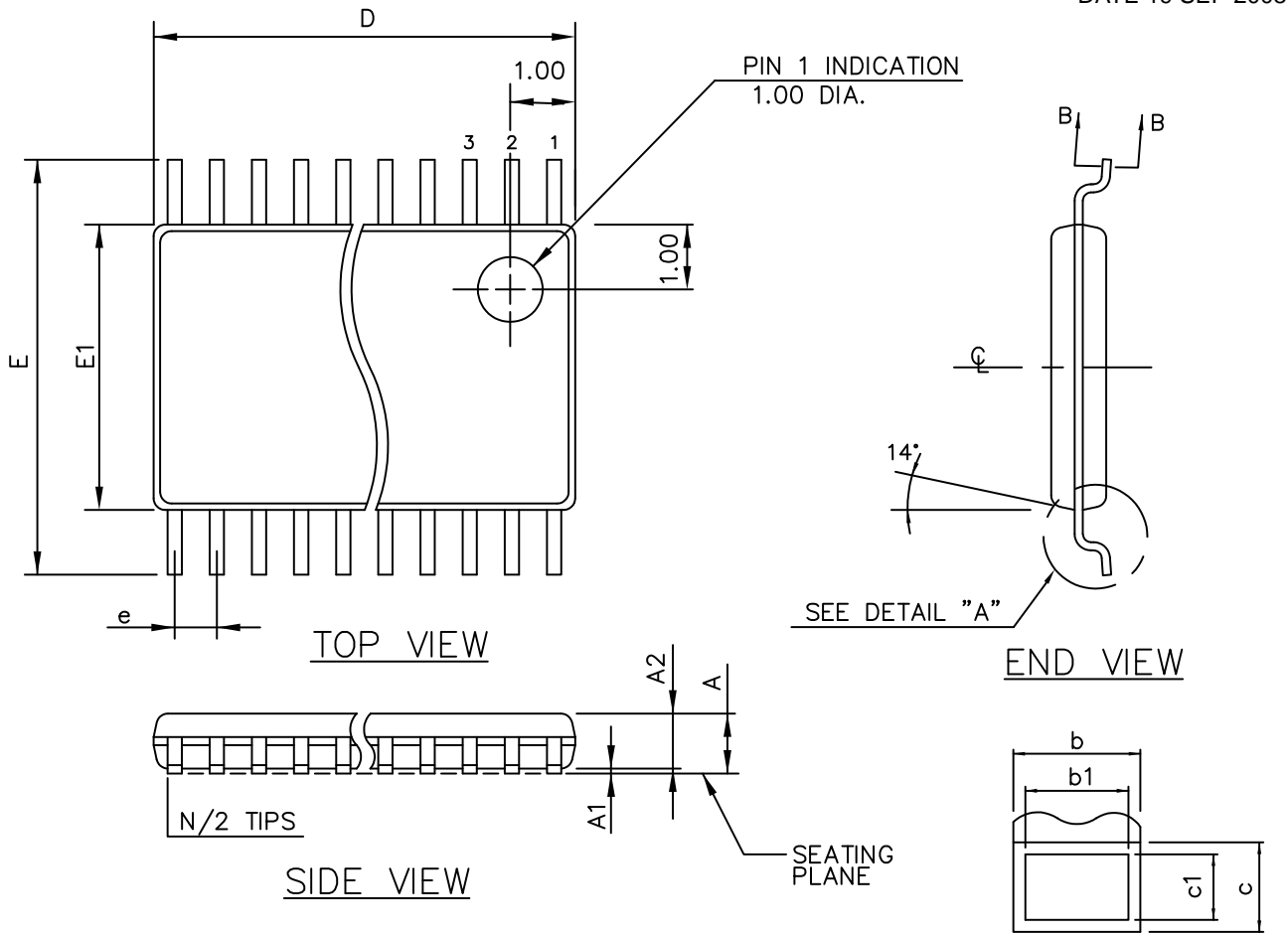

THIS TABLE FOR 0.65mm PITCH

SYMBOL	COMMON DIMENSIONS			NOTE VARIATIONS	D	N
	MIN.	NOM.	MAX.			
A	—	—	1.10	AA/AAT	3.00 BSC	8
A ₁	0.05	—	0.15	AB-1/ABT	5.00 BSC	14
A ₂	0.85	0.90	0.95	AB/ABT	5.00 BSC	16
b	0.19	—	0.30	AD/ADT	7.80 BSC	24
b1	0.19	0.22	0.25			
c	0.09	—	0.20			
c1	0.09	0.127	0.16			
D	SEE VARIATIONS					
E1	4.30	4.40	4.50			
e	0.65 BSC					
E	6.40 BSC					
L	0.50	0.60	0.70			
L1	1.00 REF					
N	SEE VARIATIONS					
X	0°	—	8°			

ALL DIMENSIONS IN MILLIMETERS

MOLD FLASH OR PROTRUSIONS SHALL NOT EXCEED 0.15mm ON D PER SIDE

DOCUMENT NUMBER:	98AON34923E	Electronic versions are uncontrolled except when accessed directly from the Document Repository. Printed versions are uncontrolled except when stamped "CONTROLLED COPY" in red.
DESCRIPTION:	TSSOP 16	PAGE 1 OF 1

onsemi and ONSEMI are trademarks of Semiconductor Components Industries, LLC dba onsemi or its subsidiaries in the United States and/or other countries. onsemi reserves the right to make changes without further notice to any products herein. onsemi makes no warranty, representation or guarantee regarding the suitability of its products for any particular purpose, nor does onsemi assume any liability arising out of the application or use of any product or circuit, and specifically disclaims any and all liability, including without limitation special, consequential or incidental damages. onsemi does not convey any license under its patent rights nor the rights of others.

onsemi, **Onsemi**, and other names, marks, and brands are registered and/or common law trademarks of Semiconductor Components Industries, LLC dba "**onsemi**" or its affiliates and/or subsidiaries in the United States and/or other countries. **onsemi** owns the rights to a number of patents, trademarks, copyrights, trade secrets, and other intellectual property. A listing of **onsemi**'s product/patent coverage may be accessed at www.onsemi.com/site/pdf/Patent-Marking.pdf. **onsemi** reserves the right to make changes at any time to any products or information herein, without notice. The information herein is provided "as-is" and **onsemi** makes no warranty, representation or guarantee regarding the accuracy of the information, product features, availability, functionality, or suitability of its products for any particular purpose, nor does **onsemi** assume any liability arising out of the application or use of any product or circuit, and specifically disclaims any and all liability, including without limitation special, consequential or incidental damages. Buyer is responsible for its products and applications using **onsemi** products, including compliance with all laws, regulations and safety requirements or standards, regardless of any support or applications information provided by **onsemi**. "Typical" parameters which may be provided in **onsemi** data sheets and/or specifications can and do vary in different applications and actual performance may vary over time. All operating parameters, including "Typicals" must be validated for each customer application by customer's technical experts. **onsemi** does not convey any license under any of its intellectual property rights nor the rights of others. **onsemi** products are not designed, intended, or authorized for use as a critical component in life support systems or any FDA Class 3 medical devices or medical devices with a same or similar classification in a foreign jurisdiction or any devices intended for implantation in the human body. Should Buyer purchase or use **onsemi** products for any such unintended or unauthorized application, Buyer shall indemnify and hold **onsemi** and its officers, employees, subsidiaries, affiliates, and distributors harmless against all claims, costs, damages, and expenses, and reasonable attorney fees arising out of, directly or indirectly, any claim of personal injury or death associated with such unintended or unauthorized use, even if such claim alleges that **onsemi** was negligent regarding the design or manufacture of the part. **onsemi** is an Equal Opportunity/Affirmative Action Employer. This literature is subject to all applicable copyright laws and is not for resale in any manner.

ADDITIONAL INFORMATION

TECHNICAL PUBLICATIONS:

Technical Library: www.onsemi.com/design/resources/technical-documentation
onsemi Website: www.onsemi.com

ONLINE SUPPORT: www.onsemi.com/support

For additional information, please contact your local Sales Representative at www.onsemi.com/support/sales