

TRCB (True Reverse-Current Blocking) Test Note

AND90275/D

TRCB (True Reverse-Current Blocking)

The true reverse-current blocking feature protects the input source against current flow from output to input regardless of whether the load switch is on or off.

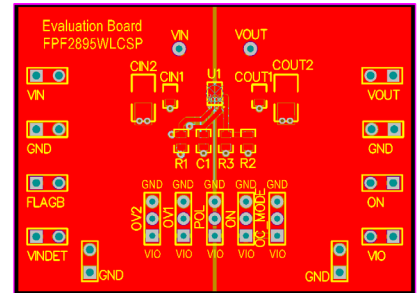
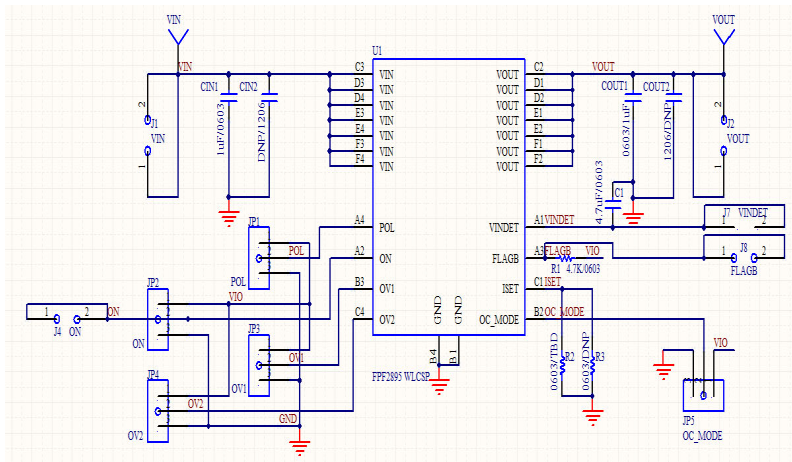

Cin2, Cout2: 0603 1 μ F
Cin1, Cout1: NC
C1: 4.7 μ F
R1: 4.7 k Ω
R3: 1.1 k Ω
R4, R2: NC

Figure 1. FPF2895 EVB Board Schematic and Top View

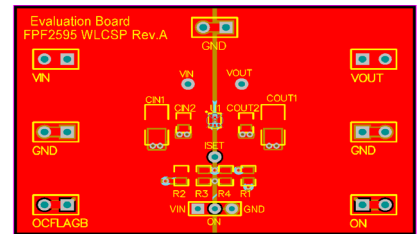
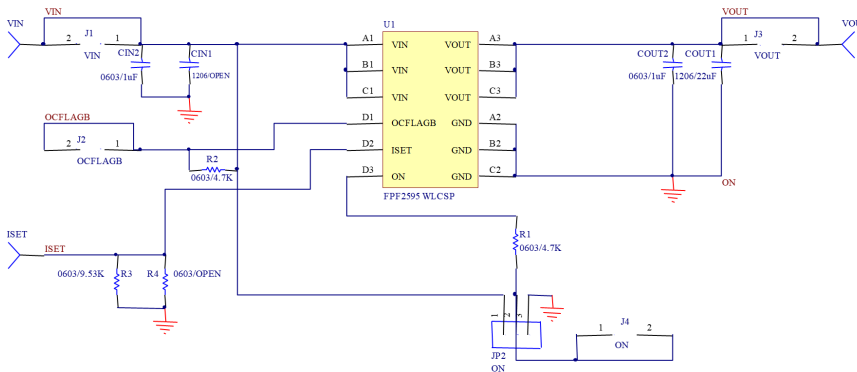

Cin2, Cout2: 0603 1 μ F
Cin1, Cout1: NC
R1, R2: 4.7 k Ω
R3: 470 Ω
R4: NC

Figure 2. FPF2595 EVB Board Schematic and Top View

TRCB Test DC Power Supply Use

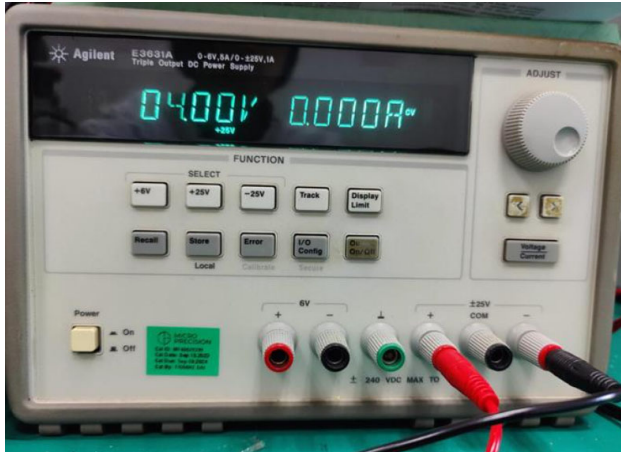

Figure 3. Agilent E3631 Power Supply

E3631 has two channels, one is 0~6 V voltage range, current max is 5 A, another one is 25 V voltage range, current is 1 A.



Figure 4. KEYSIGHT N6705C Power Supply

N6705C has four channels, CH1: 20V 3A, CH2: 20V 5A, CH3: 20V 5A, CH4: 20V 10A.

TRCB PARAMETERS

| Symbol | Parameter | Condition | Min. | Typ. | Max. | Unit |
|--------------------------------|-----------------|-----------|------|------|------|------|
| FPF2895 TRCB Parameters | | | | | | |
| V_{T_RCB} | TRCB trip point | VOUT-VIN | | 25 | 40 | mV |
| V_{R_RCB} | Release point | VIN-VOUT | | 25 | 40 | mV |
| FPF2595 TRCB Parameters | | | | | | |
| V_{T_RCB} | TRCB trip point | VOUT-VIN | | 50 | | mV |
| V_{R_RCB} | Release point | VIN-VOUT | | 50 | | mV |

TRCB Operation

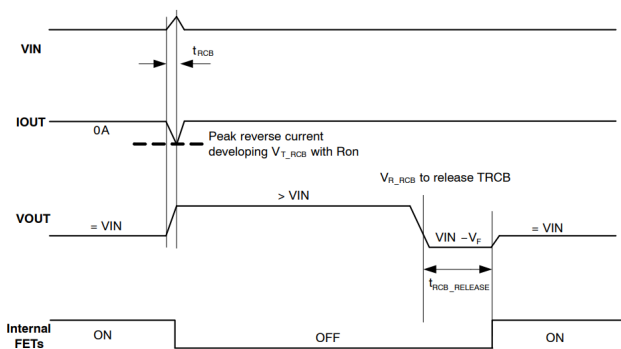

Figure 5. TRCB Behaviors

The TRCB trigger condition is VOUT should be higher than VIN threshold volt V_{T_RCB} .

FPF2895 VIN = 4 V powered by E3631

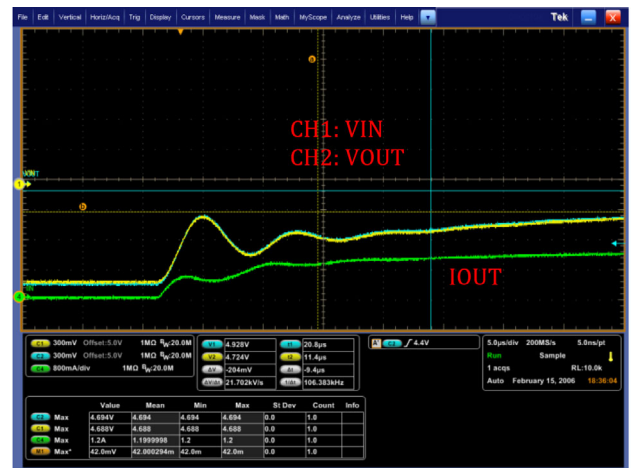

Figure 6. Experiment 1

5 V powered by the N6705C CH4, then plug into VOUT rapidly, we can see the VIN will follow up the difference between VOUT and VIN not meet the V_{T_RCB} threshold, so test Fail. See the Figure 6.

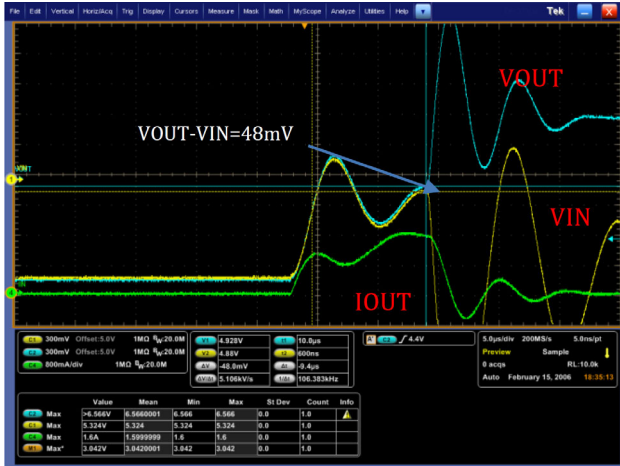

Figure 7. Experiment 2

The Figure 7. Test 5.5 V powered by the N6705C CH4 then plug into VOUT rapidly, we can see if increase the VOUT volt, the difference between VOUT and VIN can meet the V_{T_RCB} threshold, the switch turned off the TRCB behavior test PASS.

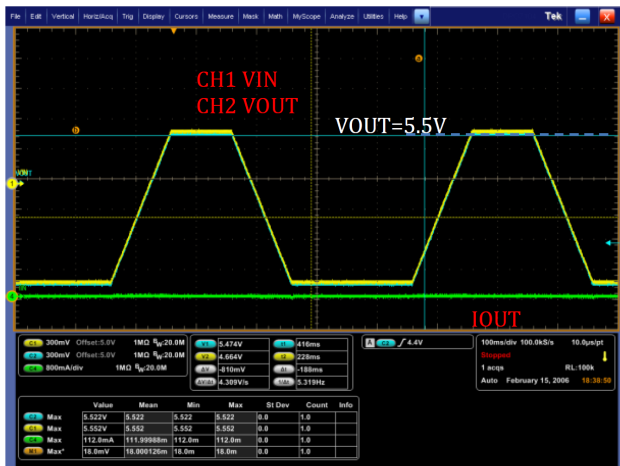

Figure 8. Experiment 3

VOUT powered by the N6705C CH4 4 V to 5.5 V 0.1 s time slew rate, VIN follow VOUT to 5.5 V, the difference between VIN and VOUT volt can not trigger the V_{T_RCB} threshold, test TRCB behavior Fail. See the Figure 8.



Figure 9. Experiment 4

VOUT powered by the N6705C CH4 4 V to 5.5 V 0.01 s time slew rate, VIN follow VOUT to 5.5 V, the difference between VIN and VOUT volt can not trigger the V_{T_RCB} threshold, test TRCB behavior Fail. See the Figure 9.

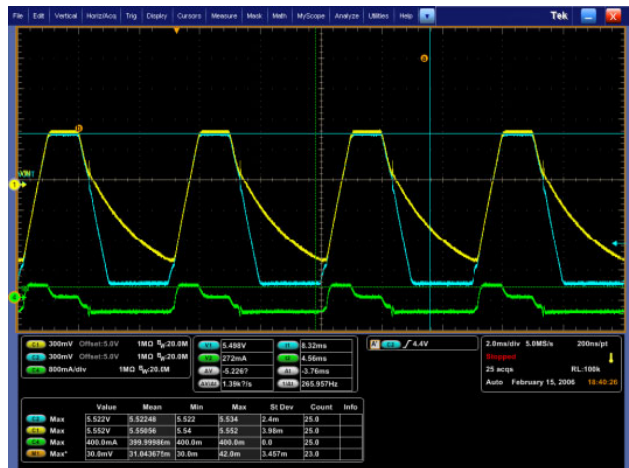

Figure 10. Experiment 5

VOUT powered by the N6705C CH4 4 V to 5.5 V 0.001 s time slew rate, VIN follow VOUT to 5.5 V, the difference between VIN and VOUT volt can not trigger the V_{T_RCB} threshold, test TRCB behavior Fail. See the Figure 10.

FPF2895 VIN = 4 V powered by N6705C

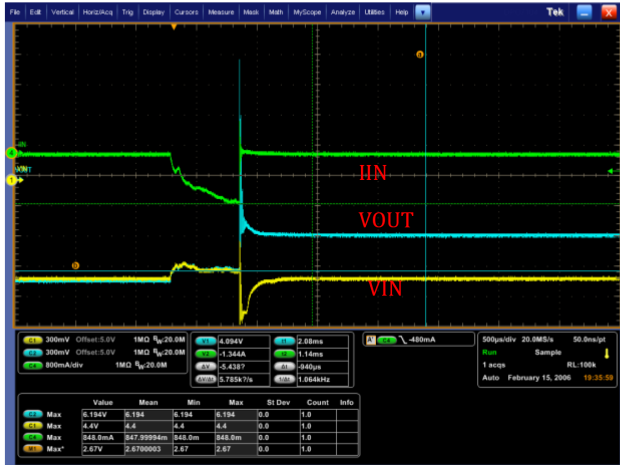

Figure 11. Experiment 6

4.4 V powered by the N6705C CH3. Then plug into VOUT rapidly, the TRCB behavior test PASS, see Figure 11.



Figure 12. Experiment 7

VOUT powered by the N6705C CH3 4 V to 4.4 V 0.1 s time slew rate, TRCB behavior test PASS, see Figure 12.



Figure 13. Experiment 8

VOUT powered by the N6705C CH3 4 V to 4.4 V 1 s time slew rate, TRCB behavior test PASS, see Figure 13.



Figure 14. Experiment 9

VOUT powered by the N6705C CH3 4 V to 4.2 V 0.1 s time slew rate, TRCB behavior test FAIL, because the difference between VIN and VOUT is 44 mV not meet the VT_RCB threshold. The TRCB test FAIL. See Figure 14.

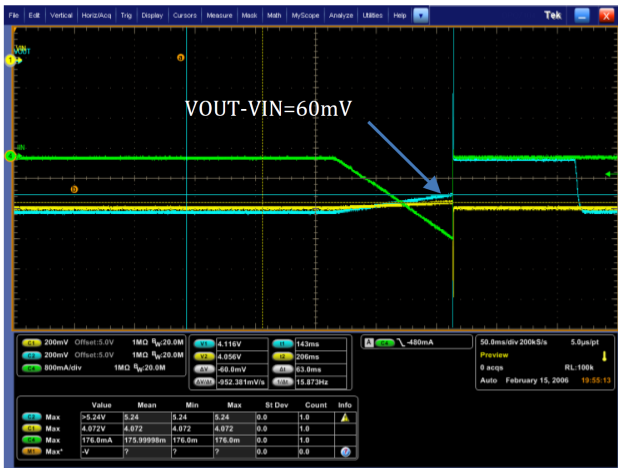

Figure 15. Experiment 10

VOUT powered by the N6705C CH3 4 V to 4.3 V 0.1 s time slew rate, TRCB behavior test PASS, see Figure 15.



Figure 16. Experiment 11

VOUT powered by the N6705C CH3 4 V to 4.3 V 0.1 s time slew rate, but CH3 current limit set is 1.5 A, the VOUT will also not increase to the VTRCB threshold the TRCB behavior test FAIL. See Figure 16.

TRCB Test Summary

- TRCB trigger must VOUT is more than VIN the VT_RCB threshold, then will see TRCB turn off the switch the normal behavior.
- TRCB behavior test the VOUT power supply capacity must enough and the current limit more than (VT_RCB/RON) can meet the VTRCB condition, Otherwise, the VOUT does not have enough force to rise up to the threshold voltage. The TRCB behavior will test FAIL.
- TRCB behavior test the VIN power supply is better use precision power supply such as N6705C which has high current limit and strong voltage regulation will not follow by the VOUT rise , otherwise, there is no chance make the VOUT is more than VIN threshold voltage. The TRCB behavior will test FAIL.

onsemi, onsemi, and other names, marks, and brands are registered and/or common law trademarks of Semiconductor Components Industries, LLC dba "onsemi" or its affiliates and/or subsidiaries in the United States and/or other countries. onsemi owns the rights to a number of patents, trademarks, copyrights, trade secrets, and other intellectual property. A listing of onsemi's product/patent coverage may be accessed at www.onsemi.com/site/pdf/Patent-Marking.pdf. onsemi reserves the right to make changes at any time to any products or information herein, without notice. The information herein is provided "as-is" and onsemi makes no warranty, representation or guarantee regarding the accuracy of the information, product features, availability, functionality, or suitability of its products for any particular purpose, nor does onsemi assume any liability arising out of the application or use of any product or circuit, and specifically disclaims any and all liability, including without limitation special, consequential or incidental damages. Buyer is responsible for its products and applications using onsemi products, including compliance with all laws, regulations and safety requirements or standards, regardless of any support or applications information provided by onsemi. "Typical" parameters which may be provided in onsemi data sheets and/or specifications can and do vary in different applications and actual performance may vary over time. All operating parameters, including "Typicals" must be validated for each customer application by customer's technical experts. onsemi does not convey any license under any of its intellectual property rights nor the rights of others. onsemi products are not designed, intended, or authorized for use as a critical component in life support systems or any FDA Class 3 medical devices or medical devices with a same or similar classification in a foreign jurisdiction or any devices intended for implantation in the human body. Should Buyer purchase or use onsemi products for any such unintended or unauthorized application, Buyer shall indemnify and hold onsemi and its officers, employees, subsidiaries, affiliates, and distributors harmless against all claims, costs, damages, and expenses, and reasonable attorney fees arising out of, directly or indirectly, any claim of personal injury or death associated with such unintended or unauthorized use, even if such claim alleges that onsemi was negligent regarding the design or manufacture of the part. onsemi is an Equal Opportunity/Affirmative Action Employer. This literature is subject to all applicable copyright laws and is not for resale in any manner.

ADDITIONAL INFORMATION

TECHNICAL PUBLICATIONS:
 Technical Library: www.onsemi.com/design/resources/technical-documentation
 onsemi Website: www.onsemi.com

ONLINE SUPPORT: www.onsemi.com/support
 For additional information, please contact your local Sales Representative at www.onsemi.com/support/sales