

## Considerations for the Design and Implementation of a Low Cost Integrated Driver for LED's Lighting Applications of Low and High Voltage (6V - 120V)

Alejandro Lara  
ON Semiconductor, USA

### **Abstract—**

*The increasing usage of Light Emitting Diodes (LEDs) to address different lighting applications such as traffic signals, exit signs, backlighting and general illumination have made them very popular to the point where they are now an attractive choice for all those lighting applications that were once the domain of incandescent lamps. LEDs have several advantages when compared with incandescent lamps. They offer fast turn-on, lower heat generation, lower power consumption, higher operating life, and high resistance to shock/vibration. Nevertheless, LEDs need to be driven properly to ensure optimal performance and long life. Designing and implementing an effective driver is key to obtain all the benefits of LEDs. The driver's implementation must be cost effective, which is not usually achieved with discrete components but with integrated solutions.*

### **I. INTRODUCTION**

LEDs are created from various doped semiconductor materials in the form of a P-N diode junction. When electrical current flows through the junction in the forward direction, the electrical carriers deliver energy proportional to the forward voltage drop across the diode junction, which is emitted in the form of light. The amount of energy is relatively low for low current (<30mA) infrared or red LEDs. However, for green and blue LEDs which are manufactured from higher forward voltage materials, the amount of energy is greater.

The conversion efficiency of electrical energy into light energy is very important. Today's LEDs vary between 10 and 20 percent efficiency. The rest of the energy is converted to heat. This heat must be effectively dissipated, as the operating junction temperature of the LED die must be maintained no higher than +125°C.

Since the device is being used in the forward biased mode, once the voltage applied exceeds the diode forward voltage; the current through the device can rise exponentially. Very high currents would damage the LEDs, so this is why electronic drivers must be added when LEDs are driven from any voltage source. The amount of light emitted by an LED is proportional to the amount of average current flowing through the device in

the forward bias direction. As the current is varied, the output of the light will vary in a similar way. Therefore, a light-emitting diode (LED) is essentially a PN junction semiconductor diode that emits light when current is applied.

By definition, it is a solid-state device that controls current without heated filaments and is therefore very reliable. Light Emitting Diodes have special characteristics that assure high reliability and a compatibility with electronic drive circuits.

LEDs have advantages and disadvantages when compared with other light sources such as incandescent or fluorescent lamps. The most significant advantages are fast turn-on, lower heat generation, lower power consumption, higher operating life, and high resistance to shock/vibration. Some of the disadvantages are the narrow viewing angle, near monochromatic light, limited wavelength selection, and they require electronic drive circuits for operation.

LEDs, regardless of color, have an extremely long lifetime, whenever their current and temperature limits are not exceeded.

Lumileds Lighting LLC™ [1, 2] has published lifetime data stating that after 50,000 hours the LEDs will have 70 percent or greater of the original light output. Using an engineering rule of thumb with data already collected and plotted on a semi-log graph paper, LEDs are projected to have 50 percent or greater of the original light output after 100,000 hours. There are 8736 hours in a normal year and 8760 hours during a leap year, which equates to 8742 hours per year. This calculates to over 11 years and 5 months of continuous service with light greater than 50 percent of the initial output. Remember, in order to obtain maximum life, the LEDs must be operated within the manufacturers specified limits of both current and diode junction temperature. LEDs should be used where extremely long life is desired and the cost of lamp replacement is very high.

Figure 1 shows a typical LED V – I curve. This graph in particular makes reference to the high current LED technology recently introduced by Lumileds. The maximum forward current varies with the different type, style, and manufacturer of LEDs. Lumileds has specified the maximum forward currents at 30 mA, 75 mA, 150 mA, 350 mA, and 700 mA for differently constructed LEDs.

The higher current devices have special thermally designed packages to transfer the heat to a heat sink. The same rules can apply to devices having other current ratings by simply scaling down the current and power designs.

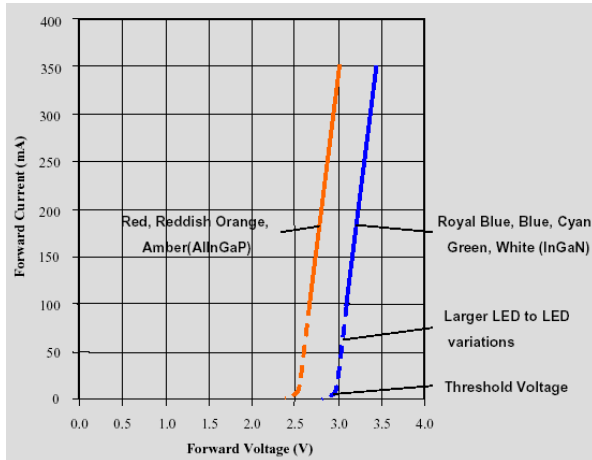

**Figure 1** – Typical V– I curve for different LED’s colors (Courtesy: Lumileds)

## II. TRADITIONAL METHODS FOR DRIVING LEDs USING DISCRETE COMPONENTS

There are several methods to drive LEDs with discrete components. Figure 1, illustrates one of the simplest using a resistor in series with the supply voltage to limit the current.

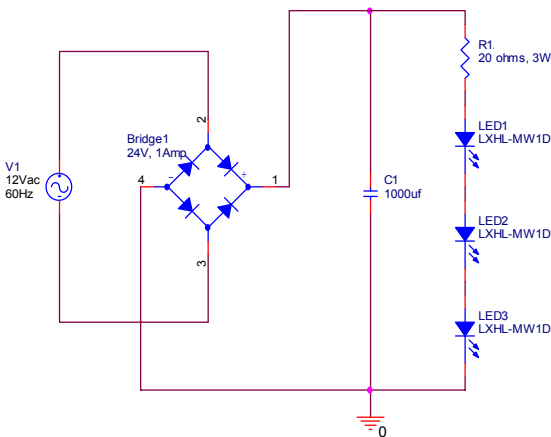

**Figure 1** – Discrete LED driver circuit using a resistor in series with the supply voltage. Application circuit for 12Vac Landscape Lighting

This type of methodology is simple and cheap but has several disadvantages. The most significant one is that since there is not any current control device, the variations in the input voltage will change the average current to the LEDs, which

results in poor illumination quality and sometimes even in the degradation or total damage of the LEDs for high line voltage conditions. To better illustrate the problem, calculations of the current supplied to the LEDs will be made based on the circuit shown in figure 1. The normal ac line can fluctuate by 10 percent and therefore the transformer output can vary between 10.8 Vac and 13.2 Vac whenever the normal secondary voltage is 12.0 Vac. Based on this, the LED’s current calculation for low, normal, and high voltage ac line is made through the formula 1:

**Formula 1:**  

$$I_{LEDs} = [(V_{in} \times \sqrt{2}) - (3 \times V_{LED})] / R1$$

Assuming that the characteristics of the LEDs used are:  $I_f=350mA$  and  $V_f=3.5V$ , then the resulting current calculation for each of the voltage line conditions is as follows:

- Low line:  $I_{LEDs} = 238 \text{ mA}$
- Normal line:  $I_{LEDs} = 323mA$
- High line:  $I_{LEDs} = 429mA$

As it can be seen, the change of the LED’s current is higher than +/- 25% for a +/-10% variation in the ac line. For the low line case, it causes the LEDs to dim while for the high line case it may potentially damage them due to the overheating caused by the high current. This is why, these type of drive circuits are not recommended nor often used because they basically eliminate the valuable features of the LEDs.

Another common LED driver method using discrete components is made through a linear regulator (MC7805, MC7809 or similar), and a series medium power resistor (usually 1W or bigger). Figure 2 shows this concept.

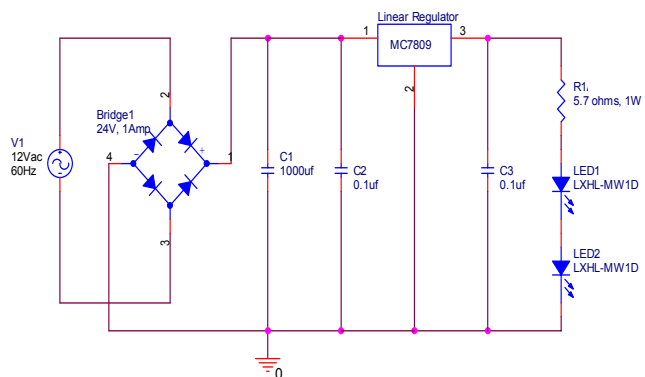

**Figure 2** – Discrete LED driver circuit using a linear regulator and a series resistor. Application circuit for 12Vac Landscape Lighting.

The LED's current is set by the regulated output voltage of the linear regulator and the value of the resistor R1. The resistor value is easily calculated through formula 2:

**Formula 2:**

$$R1 = (V_{out} - V_{LEDs}) / I_{LEDs}$$

Assuming that the characteristics of the LEDs used are:  $I_f=350mA$  and  $V_f=3.5V$ , then the resulting resistor calculation is as follows:

$$R1 = (9V - 7V) / 0.350A = 5.7 \text{ ohms}$$

The power dissipation in R1 is given by:  
 $P = I^2 \times R = (0.350)^2 \times 5.7 = 0.7 \text{ Watts}$

The current regulation is mostly dependent on the regulator's performance and should be expected to be good since most voltage regulators provide good percentage of line and load regulation, usually lower than 5%..

Although this type of concept provides good current regulation to the LEDs, it may not still be optimum for applications where cost is critical, and either for those requiring enable or electronic dimming functions.

**III. INTEGRATED LED DRIVER NUD4001 DEVICES' DESCRIPTION**

*NUD4001 Device Description.*

This integrated LED's driver is designed to replace discrete solutions for driving LEDs in low and high ac or dc voltage applications (6V -120V). Its integrated design technology eliminates individual components by combining them into a single small surface mount package (SO-8), which results in a significant reduction of both system cost & board space. Figure 3 illustrates the pin-out of the NUD4001 LED driver device.

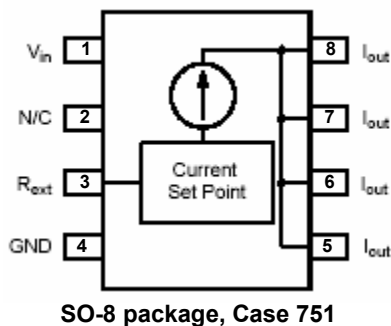

**Figure 3 – NUD4001 Integrated LED driver pin-out description.**

This device provides a regulated dc current to a LED array, from an ac or dc input. It can drive arrays of series or parallel-series LEDs for a wide range of applications. It has a low voltage overhead (1.4V) to facilitate its usage in low voltage applications. Its current regulating principle is made through the generation of a constant voltage drop (0.7V) across an external low power sense resistor ( $R_{ext}$ ), which sets the current independently of the input voltage supplied. This operating principle makes it very simple to design LED's circuits around the NUD4001 device. Nevertheless, there are certain design considerations such as the maximum device's power dissipation (1.2 Watts), operating ambient temperature range, device's voltage overhead and LED's array configuration that have to be taken into account before implementing this integrated driver. A general design guide is explained in the next paragraph and illustrated through the figure 4. In this case the device is utilized to drive three high intensity white LEDs ( $I_f=0.350A$ ,  $V_f=3.5V$ ).

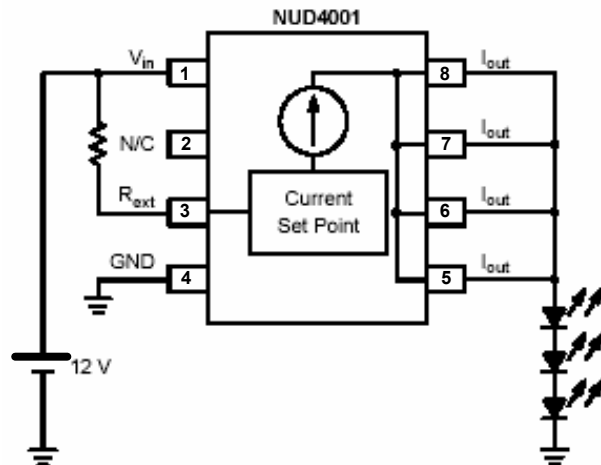

**Figure 4 – NUD4001 device driving three white high current LEDs.**

The steps to calculate the value of the external sense resistor ( $R_{ext}$ ), and to validate the operation of the device within its power dissipation capability are explained in the following design guide:

*NUD4001 device's design Guide:*

1. Determine  $I_{out}$  – LED’s current:

a.  $I_{LED} = 330 \text{ mA}$

2. Calculate Resistor Value for  $R_{ext}$ :

a.  $R_{ext} = 0.7 \text{ V} / I_{out}$

b.  $R_{ext} = 0.7/0.330 = 2.2 \text{ ohms}$

3. Define  $V_{in}$ :

a. Per Figure 4,  $V_{in} = 12 \text{ V}$

4. Define  $V_{LED}$  @  $I_{LED}$  per LED supplier’s datasheet:

a. Per Example in Figure 4,

$$V_{LED} = 3.5 \text{ V} + 3.5 \text{ V} + 3.5 \text{ V} = 10.5 \text{ V}$$

5. Calculate  $V_{drop}$  across NUD4001:

a.  $V_{drop} = V_{in} - V_{LED}$

b.  $V_{drop} = 12.0 \text{ V} - 10.5 \text{ V}$

c.  $V_{drop} = 1.5 \text{ V}$  ( $V_{drop}$  must be higher than device’s overhead, 1.4V)

6. Calculate Power Dissipation ( $P_D$ ):

a.  $P_D = V_{drop} \times I_{out}$

b.  $P_D = 1.5 \text{ V} \times 0.330 \text{ A}$

c.  $P_D = 0.495 \text{ Watts}$

7. If  $P_D > 1.25 \text{ W}$  (or derated value based on ambient temperature. Refer to figure 3 of NUD4001 device’s datasheet), then select the most appropriate recourse and repeat steps 1–6:

a. Reduce  $V_{in}$

b. Reconfigure LED array to reduce  $V_{drop}$

c. Reduce  $I_{out}$  by increasing  $R_{ext}$

d. Use parallel configuration of two or more NUD4001 devices.

The typical current regulation performance of the NUD4001 device for the circuit of figure 4 using a  $R_{ext}=2.2 \text{ ohms}$  is shown in figure 5:

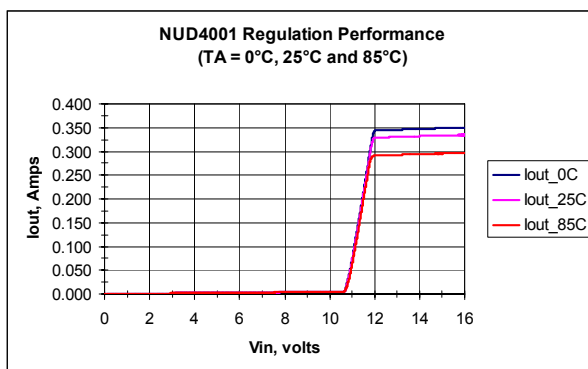

**Figure 5** – NUD4001 device regulation performance at three different ambient temperatures (0°C, 25°C and 85°C).

At 25°C, the change of the LED’s current is only 1% for an increment of 15% in the input voltage. This regulation ratings are obtained from the data shown in figure 5:

For  $V_{in} = 12\text{Vdc}$ ,  $I_{OUT} = 328\text{mA}$ ,

For  $V_{in} = 13.8\text{Vdc}$ ,  $I_{OUT} = 331\text{mA}$

Similar regulation values are obtained at low and elevated temperatures. However, it is important to note that at low temperature, the LED’s current is shifted by a factor of 5% while at elevated temperature it is lowered by a factor of 11%. These values are also obtained from the data shown in figure 5:

For  $T_A=25^\circ\text{C}$  and  $V_{in}=12.5\text{Vdc}$ ,  $I_{out}=329\text{mA}$

For  $T_A=0^\circ\text{C}$  and  $V_{in}=12.5\text{Vdc}$ ,  $I_{out} = 344\text{mA}$

For  $T_A=85^\circ\text{C}$  and  $V_{in}=12.5\text{Vdc}$ ,  $I_{out}=291\text{mA}$

Even if it seems strange, this type of behavior is ideal and usually desired by the majority of the LED manufacturers. It is because at high ambient temperatures the junction temperature in the LEDs would increase but the reduction in current cancels this effect. At low temperatures the current may be increased by a small percentage (usually no higher than 10%) since the LED’s junction temperature is colder.

NUD4001 Power Dissipation.

Although the basic design considerations of the NUD4001 device are explained in the design guide, it is necessary to emphasize and put special attention in the power dissipation ( $P_D$ ) and thermal parameters ( $R_{\theta JA}$ ) of the device as these are the main things to consider for designing around it.

The power dissipation of the SO–8 package is a function of the pad size. This can vary from the minimum pad size for soldering to a pad size given for maximum power dissipation. Power dissipation for a surface mount device is determined by the maximum rated junction temperature of the die ( $T_J$ ), the thermal resistance from the device junction to ambient ( $R_{\theta JA}$ ), and the operating ambient temperature ( $T_A$ ). Using the values provided in the NUD4001 device’s datasheet,  $P_D$  can be calculated through the formula 3:

**Formula 3:**

$$P_D = (T_J - T_A) / R_{\theta JA}$$

The NUD4001 device is rated for 1.25 Watts at  $T_A=25^\circ\text{C}$  whenever it is mounted onto FR-4, 2” pad, 1 oz coverage double side board. Its

thermal resistance junction-to-ambient is 100°C/W under the same board conditions. From formula 3, it is possible to calculate the power dissipation of the device for different ambient temperatures, which is reduced as the ambient temperature rises. Figure 6 shows the power derating graph at different ambient temperatures for the NUD4001 device (mounted onto FR-4, 2" pad, 1 oz coverage double sided board):

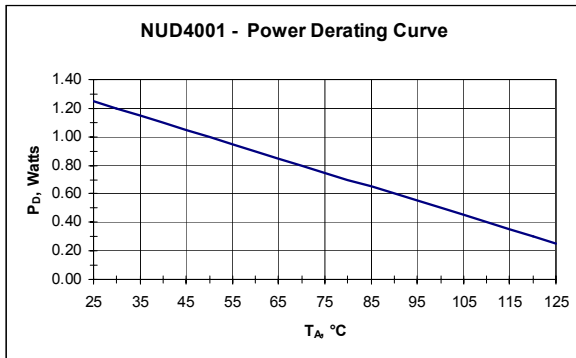
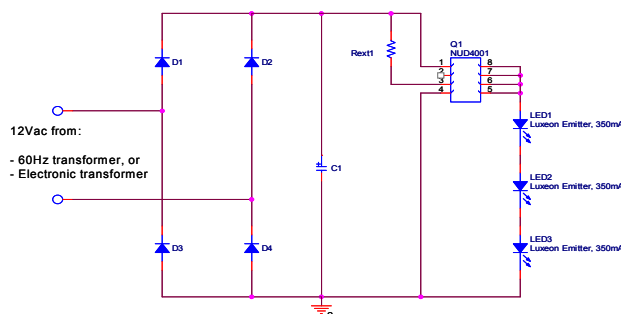

**Figure 6** – NUD4001 Power dissipation (P<sub>D</sub>) versus ambient temperature (T<sub>A</sub>).

Based on this information, it is possible to conclude that in order to optimize the LED's driver circuit design using the NUD4001 device, it is necessary to keep the ratio between V<sub>in</sub> and V<sub>LEDs</sub> as lower as possible but also higher than the device's overhead value of 1.4V. A good design window for this ratio should be between 1.5V and 2.5V for a 350mA application.

#### IV. NUD4001 DESIGN CONSIDERATIONS FOR 12VAC APPLICATION CIRCUITS.

Currently, most of the 12Vac landscape lighting applications is being designed with the new Lumiled's technology of high intensity white LEDs. This LED technology needs to be supplied with currents between 100mA and 700mA, which makes the driver's power dissipation the main design consideration. Figure 7 illustrates a typical 12Vac landscape lighting application circuit using the NUD4001 device as the LED's driver.



**Figure 7** – 12Vac landscape lighting application circuit using the NUD4001 device to drive three 350mA LEDs.

The first design consideration for the circuit shown in figure 7 is the diodes needed for rectification (D1, D2, D3 & D4), because the 12Vac input can be supplied from a 60Hz transformer or an electronic switching transformer. And therefore it is necessary to use rectifier devices with fast reverse recovery time (trr), otherwise problems will be experienced especially if an electronic switching transformer is used. The ON Semiconductor's MURA105T3 device is the ideal choice for these purposes.

Another design consideration is the voltage drop (V<sub>drop</sub>) across the NUD4001 device (Q1) as it directly impacts in the power dissipation of the device. As explained previously, V<sub>drop</sub> is dependent on the average voltage (V<sub>avg</sub>) supplied to the device and the voltage drop of the LED's array (V<sub>drop</sub>=V<sub>avg</sub>-V<sub>LEDs</sub>). For an optimum design, this V<sub>drop</sub> should be kept between 1.5 and 2.5V for a 350mA application. The value of the capacitor (C1) is an important factor to consider as V<sub>avg</sub> strongly depends on it. The value of the capacitor in farads can be determined by using the formula 4 developed by Savant [3].

#### Formula 4:

$$C = \frac{V_{MAX}}{\Delta V f_R R_L}$$

C = Value of the capacitor is farad

V<sub>MAX</sub> = Peak AC line voltage

ΔV = Peak-peak capacitor voltage normal 0.4V<sub>MAX</sub>

f<sub>R</sub> = Twice the ac line frequency (120 for a 60 Hz system)

R<sub>L</sub> = Effective load resistance

The effective load resistance (elr) is a term used for converting the LEDs and the driver into an equivalent resistance. It is the value of this resistance that is used in selecting the electrolytic capacitor. The elr is the input average voltage to the driver for a given ac line voltage value divided by the LED current. Using formula 4, it is possible to theoretically calculate the capacitor needed for the wanted V<sub>avg</sub>. In the case of figure 7, V<sub>avg</sub> is selected so that V<sub>drop</sub> is no higher than 2.5V. If the Vf of each LED is 3.5V and they all are in series, then the resulting V<sub>avg</sub> is 13V

( $V_{drop} = V_{(avg)} - V_{LEDs}$ ). Based on this and using formula 4, the capacitor is calculated as follows:

$$C = 13 / [(0.4 \times (12 \times \sqrt{2})) \times 120 \times 37.2]$$

$$C = 428 \mu\text{f}$$

The closest commercial capacitor value is 470  $\mu\text{f}$ , which gives a first approximation of the capacitor (C1) needed. This value should not be taken as the final one as it is necessary to do additional Lab analysis to validate it. It is important to notice that Formula 4 is only applicable for cases where the input voltage is supplied through a 60Hz transformer. Therefore if an electronic transformer is used then the formula is not applicable and the selection of the capacitor is most likely to be made through entirely Lab work.

The final design steps for the circuit of figure 7 are to calculate the external sense resistor ( $R_{ext}$ ), and the NUD4001 device's power dissipation ( $P_D$ ), which is made by following the steps two and six of the design guide previously explained. The resulting  $R_{ext}$  for a LED's current of 320mA is 2.2ohms, and the power dissipation for the same current value is 0.8 Watts. Based on these calculations, the resulting bill of materials (BOM) is as follows:

Part Code	Vendor	Part Number
D1 – D4	ON Semi	MURA105T3
Q1	ON Semi	NUD4001
C1	VISHAY	470uf, 25V
R1	VISHAY	2.2 ohms
LED1 – LED3	LUMILEDS	LXHL–MW1D

Figures 8a and 8b show two oscilloscope pictures of the waveforms generated across the circuit shown in figure 7 once the previous BOM is implemented. Figure 8a refers to the case where the input voltage is taken from a 60Hz transformer (Tamura 3FD-424 or similar), and figure 8b for the case of a switching transformer (Cooper LZR-404 or similar).

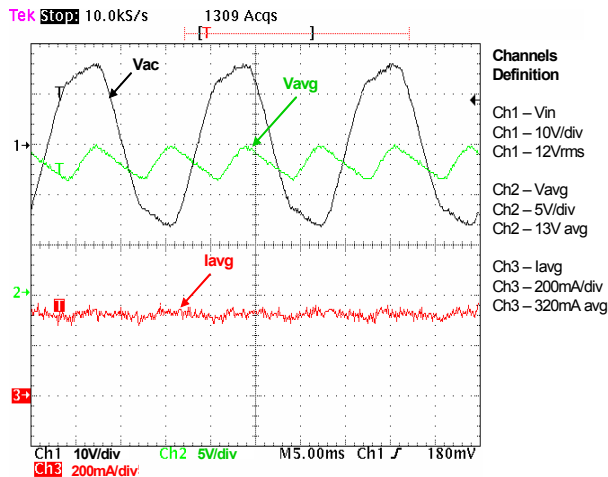

Figure 8a – Waveforms generated across the circuit

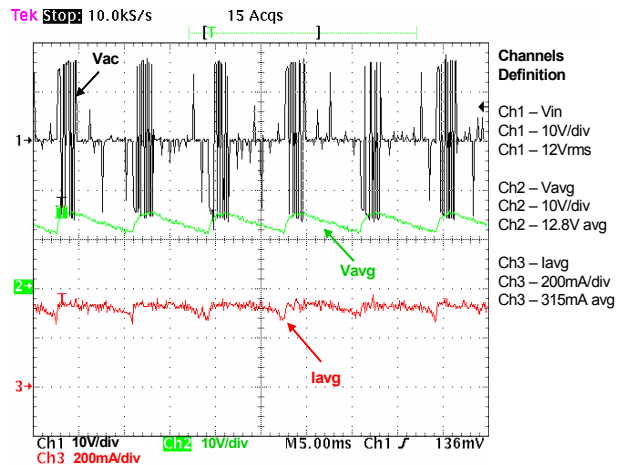

Figure 8b – Waveforms generated across the circuit shown in figure 7 when an electronic switching transformer is used for the supply voltage.

The current regulation performance of the circuit shown in figure 7 for different average voltages values resulting from variations in the ac line, is similar than the one shown in figure 5. At 25°C, the change of the LED's current is expected to be of only 1% for an increment of 15% in the input voltage.

There are some cases where the application only requires to light up one LED instead of three, so for those cases it is necessary to add an external power resistor to reduce the voltage drop ( $V_{drop}$ ) across the NUD4001 device to have it operating within its power dissipation ( $P_D$ ) capabilities. Figure 9a illustrates this circuit concept and figures 9b, 9c and 9b show the circuit regulation performance, the NUD4001 device's power dissipation, and the power dissipation in the power external resistor ( $R_{ext2}$ ) respectively.

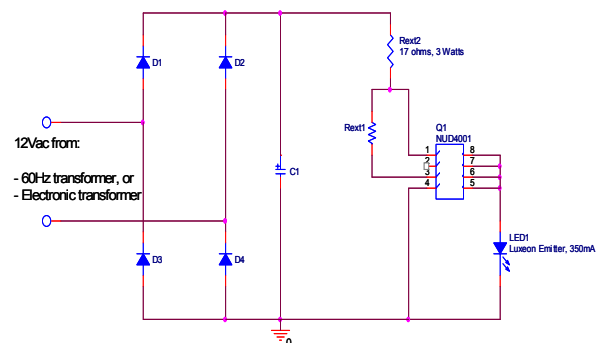

Figure 9a – 12Vac landscape lighting application

The BOM for D1–D4, C1 and Rext1 is similar to the one defined for the circuit of figure 7. The only addition to the circuit of the figure 9a is the power resistor Rext2.



Figure 9b – Current regulation performance of the circuit of figure 9a for different Vavg values.

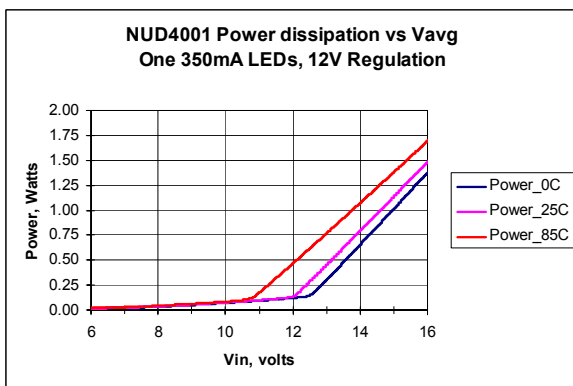
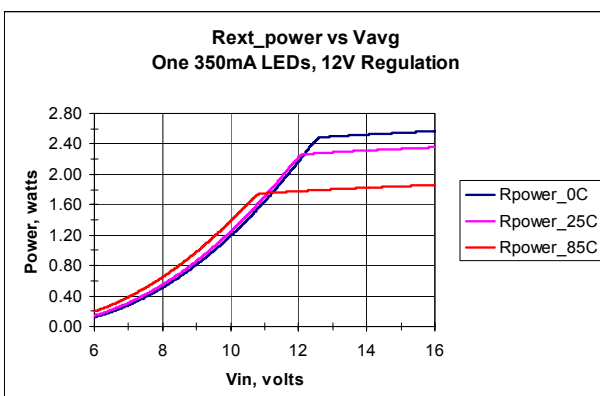

Figure 9c – NUD4001 device’s power dissipation when operating in the circuit of figure 9a for different Vavg values.



Similar circuits can be made to drive different LED arrays for low input voltage applications (6V to 24V). The main important to consider is to not exceed the power dissipation of the NUD4001 device to assure reliable operation.

### V. NUD4001 DESIGN CONSIDERATIONS FOR 120VAC APPLICATION CIRCUITS.

In addition to the already explained design considerations for the NUD4001 device, it is necessary to consider power factor requirements and transient voltage protection when designing 120Vac circuits around it. If there is no requirement for power factor, then the circuit becomes simpler as it does not need to have a full bridge rectifier nor a capacitor. Figure 10 shows a schematic diagram to drive a LED array of 30 white, low current units (30mA) for a 120Vac application using the NUD4011 device. This device is similar than the NUD4001 device but with higher breakdown voltage.

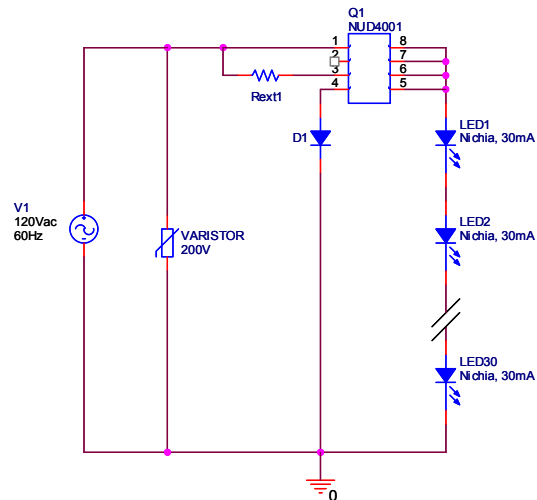

Figure 10 – 120Vac application circuit using the NUD4011 to drive 30 white low current LEDs (30mA) in series. No requirement for power factor.

For figure 10, current conduction occurs only after the peak voltage of the positive ac cycle exceeds the forward voltage of the LED array. The total forward voltage is given by the Vf voltage of a specific LED device multiplied by the number of LEDs connected in series. Assuming that Nichia white LEDs with characteristics of Vf=3.6V and If=30mA are used, then the resulting total forward voltage of the 30 series LEDs array is 108V. This indicates that current conduction is only present during the time that the positive cycle of the ac input is higher than 108V. This is something very important to consider for determining the value of the external resistor (Rext1) to set the LED's current because it is now dependent on the peak current value and the conduction time. To better illustrate this, the current peak calculation is made for the circuit shown in figure 10. Formula 5 shows the equation to calculate the instantaneous voltage over time for a sinusoidal waveform:

**Formula 5:**

$$V = V_{\text{peak}} \times \sin \theta$$

Using this formula and other analogies, it is possible to determine the time for current conduction during the positive cycle of the ac input.

As known, Vpeak happens at  $\theta = 90^\circ$  of the ac cycle, which translates to 4.165msec in time for a 60Hz frequency.

then, formula 5 is used to find  $\theta$  for 108V:

$$108V = (120 \times \sqrt{2}) \times \sin \theta;$$

$$\theta = 39.44^\circ$$

and then, it can be established that if  $90^\circ$  is 4.165msec, then  $39.44^\circ$  is 1.82msec. Based on this, the current conduction time is calculated as follows:  $(4.165\text{msec} - 1.82\text{msec}) \times 2 = 4.67\text{msec}$ .

Assuming that the 60Hz current waveform is square shaped, it is possible to say that 16.66msec is 100% duty cycle, and 4.67msec is 28%, therefore:

$$I(\text{avg}) = I_{\text{peak}} \times \text{duty cycle};$$

If the average LED current wanted is 25mA

$$I_{\text{peak}} = I(\text{avg}) / \text{duty cycle}$$

$$I_{\text{peak}} = 25\text{mA} / 0.28$$

$$I_{\text{peak}} = 89.2 \text{ mA}$$

Upon the calculation of the Ipeak, it is possible to calculate Rext:

$$R_{\text{ext}} = 0.7V / I_{\text{peak}}$$

$$R_{\text{ext}} = 7.84 \text{ ohms}$$

This theoretical procedure provides a way to have a first approximation for the value of the Rext needed. However it should not be taken as final until validated through Lab analysis or SPICE simulations. Figure 11 shows the expected current waveforms in the LED's array for the circuit shown in figure 10, with Rext=7.8 ohms.

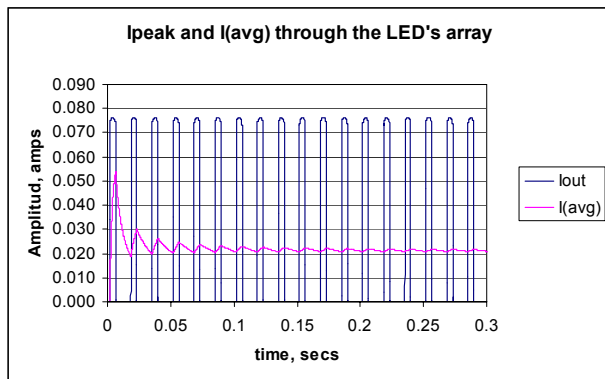

**Figure 11** – Ipeak and I(avg) waveforms through the LED's array for the circuit shown in figure 10, with Rext=7.8 ohms.

As it can be observed, the Ipeak and I(avg) values do not exactly match with the calculated ones. So this is why, it is very important to do Lab analysis for validation.

The power dissipation of the NUD4011 device for the circuit shown in figure 10 is calculated as follows:

$$P_D = [(V_{\text{peak}} - V_{\text{LEDs}}) \times I(\text{avg})] \times 0.28$$

$$P_D = 0.434 \text{ watts}$$

In order to achieve lower power dissipation in the led driver (NUD4011), it is necessary to configure the LED's array in a way so that the total Vf is close enough to the voltage applied to it.

If the application has power factor requirements, then it is necessary to use a full bridge rectifier across the ac input to keep in phase the current and voltage waveforms as much as possible. The Rext calculation is made through the same procedure already explained. The only variation is the frequency which is increased to 120Hz because of the usage of a full bridge rectifier. The

frequency affects the duty cycle and therefore the peak calculation.

### VI. NUD4001 DEVICE'S PWM AND ENABLE FUNCTIONS.

In addition to the current regulation function, the NUD4001 device offers the ability to PWM the LEDs for dimming applications by using an external small signal NPN transistor connected between pin 4 and ground. This is a very important feature specially for those applications where multicolor lighting is required (swimming pools, bars, etc). The same small signal transistor can be used for an enable function for conditioning applications. Figure 12 illustrates the circuit for PWM function in a 12Vdc application to drive three high current (350mA) white LEDs.

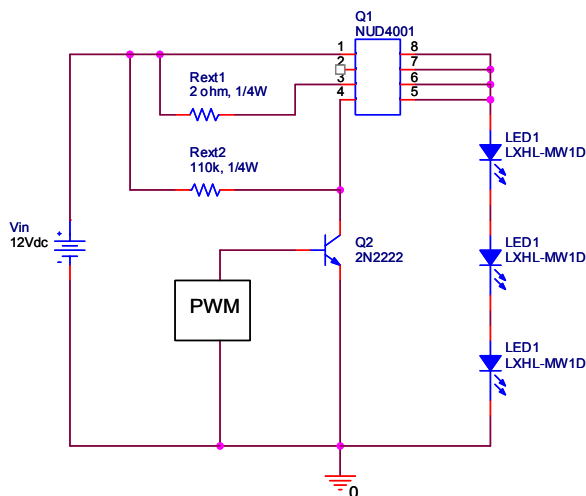

**Figure 12** – NUD4001 device's configuration for PWM function.

The function of Rext2 is to pull up the pin 4 of the device when the PWM signal in the base of the NPN transistor is low. The average current applied to the LED is directly dependent on the duty cycle ( $I_{avg} = I_{peak} \times \text{duty cycle}$ ). And the LED's light intensity is directly dependent on the average current  $I_{avg}$  applied. In the case of figure 12, the current is set to be 350mA at 100% duty cycle and therefore, it proportionally decreases for narrower duty cycles. The PWM circuit is good for frequencies no higher than 100KHz.

The same type of configuration is used for the enable function. The only difference is the way that the base of the NPN transistor is driven. The same concepts can be applied for high voltage

applications, the only thing to consider is to select a transistor with high enough breakdown voltage.

### VI. SUMMARY

#### Discrete methods.

Discrete methods to drive LEDs are not recommended nor often used because they basically eliminate the valuable features of LEDs, and sometimes even cause total damage.

#### Linear Regulators.

Although the concept of linear regulators provide good current regulation for LED's circuits, it may not still be optimum for applications where cost is critical, and either for those applications requiring enable or electronic dimming functions.

#### NUD4001 Device.

The NUD4001 device offers a low cost current regulation integrated solution for different LED's circuits of high and low ac/dc voltage (6V – 12V).

Design considerations such as the device's power dissipation, breakdown voltage and maximum current capability have to be taken into account before implementation in application circuits.

Selection of the proper LED's configuration to drop as much as possible of the supply voltage in the LED array is key to achieve design optimization.

Selection of the proper copper area according to the application needs and device's specifications is key to achieving optimum device's operation.

The enable and PWM features as well as the low cost implementation is what distinguishes and most of the time makes the difference of using the NUD4001 device versus linear regulators and discrete solutions to drive LEDs for low and high voltage applications.

### REFERENCES

- [1] ON Semiconductor site [www.onsemi.com](http://www.onsemi.com)
- [2] A.E. Fitzgerald, David E. Higginbotham, Arvin  
Basic Electrical Engineering, fifth edition, 1981.
- [3] Jim Spangler's application note draft 021218

ON Semiconductor, October 2003.

- [4] Lumiled, [www.lumiled.com](http://www.lumiled.com)
- [5] Nichia, [www.nichia.com](http://www.nichia.com)
- [6] Circuit Networks, Robert L. Boylestad  
Eighth edition, August 1988
- [7] PSPICE release 9.1. Released notes  
February 2000.
- [8] ON Semiconductor's datasheets  
NUD4001  
NUD4011